

# **STATEMENT OF WORK AND SPECIFICATIONS**

**Issued for RFP**

**Revision 0**

**LAKE SIDE POWER PROJECT  
BLOCK 2**

**PACIFICORP**

# TABLE OF CONTENTS

<b>SECTION 1.0 - INTRODUCTION .....</b>	<b>1-1</b>
1.1.1 General Project Description .....	1-1
1.1.2 Specifications .....	1-2
<b>1.2 OVERALL SCOPE DESCRIPTION .....</b>	<b>1-2</b>
1.2.1 General Scope .....	1-2
1.2.2 Work by Others .....	1-3
1.2.3 Terminal Points .....	1-4
1.2.4 Owner Furnished Equipment and Systems .....	1-5
1.2.5 Noise Levels .....	1-6
1.2.6 Mechanical Scope .....	1-7
1.2.7 Electrical Scope .....	1-8
1.2.8 Instrumentation and Control Scope .....	1-9
1.2.9 Civil Scope .....	1-9
1.2.10 Structural and Architectural Scope .....	1-10
1.2.11 Construction Facilities and Services .....	1-10
1.2.12 Production Inputs .....	1-15
1.2.13 Operating Consumables .....	1-16
<b>1.3 PLANT OPERATING PROFILE .....</b>	<b>1-17</b>
1.3.1 Plant Load Definition .....	1-17
1.3.2 Plant Operating Profile .....	1-17
1.3.3 Plant Operating Philosophy .....	1-18
1.3.4 Plant Reliability .....	1-18
1.3.5 Plant Performance .....	1-18
<b>SECTION 2.0 - DESIGN CONDITIONS .....</b>	<b>2-1</b>
2.1 GEOTECHNICAL CONDITION .....	2-1
2.2 SITE SECURITY .....	2-2
2.3 SITE ACCESS .....	2-2
2.4 SITE ENVIRONMENT .....	2-2
<b>SECTION 3.0 - CODES, STANDARDS, AND REGULATIONS .....</b>	<b>3-1</b>
<b>SECTION 4.0 - ENGINEERING SCOPE .....</b>	<b>4-1</b>
4.1 GENERAL REQUIREMENTS .....	4-1
4.1.1 Architectural Design .....	4-3
4.1.2 Civil / Structural Design .....	4-3
4.1.3 Mechanical Design .....	4-4
4.1.4 Electrical Design .....	4-5
4.1.5 Instrumentation and Controls Design .....	4-5
4.2 DESIGN REVIEWS .....	4-6

<b>4.3 DRAWING AND SPECIFICATION REQUIREMENTS.....</b>	<b>4-6</b>
4.3.1 Drawing and Specification Schedule .....	4-7
4.3.2 Drawing and Specification Submittals.....	4-7
4.3.3 Plant Manual and Instruction Books .....	4-13
4.3.4 System Startup & Commissioning Test Procedures and Reports.....	4-14
4.3.5 Project Administration Manual.....	4-14
4.3.6 Critical Path Schedule.....	4-15
4.3.7 Project Status Reports.....	4-15
4.3.8 Coordination Meetings.....	4-15
4.3.9 Contractor Acquired Permits.....	4-15
<b>4.4 QUALITY ASSURANCE.....</b>	<b>4-16</b>
<b>SECTION 5.0 - MECHANICAL SCOPE .....</b>	<b>5-1</b>
<b>5.1 GENERAL REQUIREMENTS .....</b>	<b>5-1</b>
5.1.1 General.....	5-1
5.1.2 Piping.....	5-2
5.1.3 General Arrangements .....	5-2
5.1.4 Platforms.....	5-2
5.1.5 Accessways and Clearances.....	5-4
<b>5.2 MECHANICAL SYSTEMS AND EQUIPMENT .....</b>	<b>5-5</b>
5.2.1 General.....	5-5
5.2.2 Pumps - General.....	5-6
5.2.3 Tanks and Vessels - General.....	5-7
5.2.4 Heat Exchangers - General.....	5-8
5.2.5 Combustion Turbine Generator (CTG) System .....	5-8
5.2.6 Steam Turbine (STG) System.....	5-22
5.2.7 Combustion and Steam Turbine Electrical Generator.....	5-35
5.2.8 Heat Recovery Steam Generator (HRSG) System.....	5-48
5.2.9 Blowdown System .....	5-76
5.2.10 Steam Systems .....	5-77
5.2.11 Condensate System .....	5-79
5.2.12 Boiler Feedwater System .....	5-81
5.2.13 Raw Water Supply System .....	5-82
5.2.14 Service Water System .....	5-82
5.2.15 Demineralization System .....	5-82
5.2.16 Condenser Air Removal System.....	5-85
5.2.17 Circulating Water System.....	5-86
5.2.18 Chemical Injection Systems.....	5-90
5.2.19 Closed Cooling Water System.....	5-92
5.2.20 Fuel Gas System .....	5-93
5.2.21 Compressed Air System.....	5-95
5.2.22 Sampling and Analysis System.....	5-96
5.2.23 Fire Protection System.....	5-98
5.2.24 Potable Water System .....	5-99
5.2.25 Process Bulk Gas Storage and Distribution System.....	5-101
5.2.26 Waste Water Collection and Transfer System .....	5-102
5.2.27 Heating, Ventilating, and Air Conditioning System .....	5-103
<b>5.3 PLANT PIPING REQUIREMENTS.....</b>	<b>5-105</b>
5.3.1 General Requirements.....	5-105
5.3.2 Piping Classes .....	5-107
5.3.3 Line List.....	5-110

5.3.4	Clearances .....	5-110
5.3.5	Piping Stress Analysis.....	5-110
5.3.6	Pipe Bending.....	5-111
5.3.7	Pipe Sleeves .....	5-111
5.3.8	Dissimilar Metal Joints .....	5-111
5.3.9	Equipment for Plant Start-up .....	5-111
5.3.10	Sewer and Underground Piping .....	5-112
5.3.11	Vents and Drains and Manholes .....	5-112
5.3.12	Root Valves.....	5-112
5.3.13	Root Connections.....	5-112
5.3.14	Fabrication Requirements .....	5-113
5.3.15	Shop Cleaning.....	5-113
5.3.16	Inspection.....	5-114
5.3.17	Protection for Shipment and Construction.....	5-114
5.3.18	Welding.....	5-114
5.3.19	Field Installation .....	5-114
5.3.20	Pipe Supports, Guides, Restraints and Anchors.....	5-115
5.3.21	Painting.....	5-119
5.3.22	Testing .....	5-120
<b>5.4</b>	<b>VALVES.....</b>	<b>5-120</b>
5.4.1	General Requirements.....	5-120
5.4.2	Valve List.....	5-121
5.4.3	Valve Materials.....	5-121
5.4.4	Valve Shop Painting.....	5-121
5.4.5	Lubricant Materials.....	5-121
5.4.6	Design Requirements.....	5-121
5.4.7	Valve Operators .....	5-122
<b>5.5</b>	<b>INSULATION AND JACKETING .....</b>	<b>5-123</b>
5.5.1	General Requirements.....	5-123
<b>SECTION 6.0 - CIVIL SCOPE .....</b>	<b>6-1</b>	
<b>6.1 GENERAL REQUIREMENTS .....</b>	<b>6-1</b>	
6.1.1	Units.....	6-2
6.1.2	Geotechnical .....	6-2
<b>6.2 SITE PREPARATION AND MAINTENANCE.....</b>	<b>6-2</b>	
6.2.1	Site Preparation.....	6-2
6.2.2	Drainage.....	6-2
6.2.3	Erosion .....	6-3
6.2.4	Debris.....	6-3
6.2.5	Road Maintenance.....	6-3
6.2.6	Signs and Barricades .....	6-3
6.2.7	Dust Control.....	6-3
6.2.8	Open Burning.....	6-3
6.2.9	Excavation, Filling, and Backfilling .....	6-3
6.2.10	Site Grading .....	6-4
<b>6.3 SITE IMPROVEMENTS .....</b>	<b>6-4</b>	
6.3.1	Storm Water Drainage System.....	6-4
6.3.2	Sanitary System .....	6-5
6.3.3	Fencing and Gates.....	6-5
6.3.4	Surfacing.....	6-5

6.3.5	Manholes.....	6-5
6.3.6	Duct Banks.....	6-5
6.3.7	Landscaping.....	6-5
6.3.8	Roads and Parking.....	6-5
6.3.9	Oil/Water Separation.....	6-7
6.3.10	Plant Material Unloading Areas.....	6-7

**SECTION 7.0 - STRUCTURAL SCOPE.....7-1**

<b>7.1</b>	<b>MATERIALS.....</b>	<b>7-1</b>
7.1.1	Steel.....	7-1
7.1.2	Concrete.....	7-1
<b>7.2</b>	<b>STRUCTURAL LOADING.....</b>	<b>7-3</b>
7.2.1	Dead Loads.....	7-3
7.2.2	Live Loads.....	7-3
7.2.3	Wind Loads.....	7-3
7.2.4	Seismic.....	7-3
7.2.5	Thermal Loads.....	7-3
7.2.6	Crane Loads.....	7-3
7.2.7	Vehicle Loads.....	7-4
7.2.8	Pipe and Equipment Anchor Loads.....	7-4
<b>7.3</b>	<b>STRUCTURAL FOUNDATIONS.....</b>	<b>7-4</b>
7.3.1	Turbine Foundations & Containment.....	7-4
7.3.2	Buildings and Equipment Foundation.....	7-5
7.3.3	Tank Foundation.....	7-5
7.3.4	Transformer Foundation and Containment.....	7-5
<b>7.4</b>	<b>ARCHITECTURAL.....</b>	<b>7-5</b>
7.4.1	Siding.....	7-6
7.4.2	Roofing.....	7-6
7.4.3	Interior Construction Materials.....	7-6
7.4.4	Platforms.....	7-7
7.4.5	Stairs.....	7-7
7.4.6	Handrail.....	7-8
7.4.7	Windows, Window Walls, Entrance Doors, and Louvers.....	7-8
7.4.8	Painting.....	7-8
<b>7.5</b>	<b>BUILDINGS / STRUCTURES.....</b>	<b>7-11</b>
7.5.1	Minimum requirements.....	7-11
7.5.2	Steam Turbine Generator Building.....	7-12
7.5.3	Other Structures.....	7-12
7.5.4	HRSG Equipment Enclosure.....	7-12
<b>7.6</b>	<b>Turbine Room Crane.....</b>	<b>7-12</b>

**SECTION 8.0 - ELECTRICAL SCOPE.....8-1**

<b>8.1</b>	<b>GENERAL REQUIREMENTS.....</b>	<b>8-1</b>
8.1.1	Plant System Studies.....	8-1
8.1.2	Interface Requirements.....	8-3
8.1.3	Auxiliary Power Supply Equipment.....	8-5
8.1.4	Classification of Hazardous Areas.....	8-6

8.1.5	Lighting.....	8-6
8.1.6	Telephone and Data Systems .....	8-7
8.1.7	Construction Power.....	8-8
8.1.8	Freeze Protection .....	8-8
8.1.9	Cathodic Protection System.....	8-8
8.1.10	Lightning Protection .....	8-9
<b>8.2</b>	<b>ELECTRICAL PROTECTIVE SYSTEMS.....</b>	<b>8-9</b>
8.2.1	Generator Protective Relays.....	8-9
8.2.2	Generator Step-up Transformer Relays.....	8-10
8.2.3	Unit Auxiliary Transformer Relays.....	8-10
8.2.4	Medium Voltage Switchgear and Motor Controllers .....	8-10
<b>8.3</b>	<b>SWITCHYARD.....</b>	<b>8-10</b>
8.3.1	Deadend Structures .....	8-10
<b>8.4</b>	<b>GENERATOR STEPUP TRANSFORMERS.....</b>	<b>8-11</b>
<b>8.5</b>	<b>PLANT AUXILIARY TRANSFORMERS.....</b>	<b>8-13</b>
<b>8.6</b>	<b>4160 VOLT METAL-CLAD SWITCHGEAR.....</b>	<b>8-15</b>
8.6.1	General.....	8-15
<b>8.7</b>	<b>4160 VOLT MOTOR CONTROL CENTERS .....</b>	<b>8-16</b>
8.7.1	General.....	8-16
<b>8.8</b>	<b>480 VOLT SECONDARY UNIT SUBSTATIONS.....</b>	<b>8-16</b>
8.8.1	General.....	8-16
<b>8.9</b>	<b>480V MOTOR CONTROL CENTERS.....</b>	<b>8-18</b>
8.9.1	General.....	8-18
8.9.2	Circuit Breakers .....	8-18
8.9.3	Combination Starter Units .....	8-19
<b>8.10</b>	<b>GENERATOR TERMINAL EQUIPMENT/ISOLATED PHASE BUS DUCT .....</b>	<b>8-19</b>
8.10.1	GT Generator Bus Duct/Auxiliary Power Connections .....	8-19
8.10.2	Low Side Generator Breakers .....	8-19
8.10.3	ST Generator Bus Duct.....	8-20
<b>8.11</b>	<b>NON-SEGREGATED PHASE BUS DUCT.....</b>	<b>8-20</b>
8.11.1	General.....	8-20
8.11.2	Bus Enclosures.....	8-20
8.11.3	Bus Conductors.....	8-21
<b>8.12</b>	<b>BATTERY/UPS SYSTEM.....</b>	<b>8-21</b>
8.12.1	Codes and Standards .....	8-21
8.12.2	Design and Construction .....	8-21
8.12.3	Rating.....	8-22
8.12.4	Duty Cycle .....	8-22
8.12.5	Battery Charger Requirements .....	8-22
8.12.6	UPS Equipment Requirements.....	8-23
8.12.7	Distribution Panelboards.....	8-25
8.12.8	Construction Details.....	8-25
<b>8.13</b>	<b>EMERGENCY DIESEL GENERATOR .....</b>	<b>8-26</b>

8.13.1 General.....	8-26
<b>8.14 ELECTRIC MOTORS .....</b>	<b>8-26</b>
8.14.1 4000 and 460 Volt Integral Horsepower Motors.....	8-27
8.14.2 Fractional Horsepower Motors .....	8-29
<b>8.15 RACEWAY .....</b>	<b>8-30</b>
8.15.1 Routing of Above Grade Raceway and Conduit.....	8-31
8.15.2 Electrical Cable Tray System.....	8-32
8.15.3 Covers .....	8-33
8.15.4 Tray Supports.....	8-33
8.15.5 Material.....	8-33
<b>8.16 CONDUCTORS .....</b>	<b>8-34</b>
8.16.1 Cable Specifications.....	8-34
<b>8.17 GROUNDING.....</b>	<b>8-36</b>
8.17.1 Ground Grid Design.....	8-37
<b>8.18 PLANT SECURITY SYSTEM .....</b>	<b>8-38</b>
<b>8.19 ELECTRICAL TESTING.....</b>	<b>8-38</b>
<b>SECTION 9.0 - INSTRUMENTATION AND CONTROLS SCOPE .....</b>	<b>9-1</b>
<b>9.1 GENERAL REQUIREMENTS .....</b>	<b>9-1</b>
<b>9.2 DISTRIBUTED CONTROL SYSTEM (DCS) .....</b>	<b>9-2</b>
<b>9.3 DCS CONTROLLERS AND I/O .....</b>	<b>9-5</b>
<b>9.4 INTERFACES AND NETWORKS .....</b>	<b>9-6</b>
<b>9.5 REMOTE TERMINAL UNIT (RTU) DISPATCH.....</b>	<b>9-6</b>
<b>9.6 DCS FACTORY ACCEPTANCE TEST (FAT).....</b>	<b>9-7</b>
<b>9.7 HARD PANEL CONTROL BOARD .....</b>	<b>9-7</b>
<b>9.8 INSTRUMENTATION AND CONTROL DEVICES .....</b>	<b>9-7</b>
9.8.1 General.....	9-7
9.8.2 Thermocouples and Resistance Temperature Detectors.....	9-8
9.8.3 Thermowells .....	9-8
9.8.4 Flow Elements .....	9-8
9.8.5 Transmitters .....	9-8
9.8.6 Gas Meters .....	9-9
9.8.7 Temperature, Pressure, Level, and Flow Switches .....	9-9
9.8.8 Local Indicators .....	9-9
9.8.9 Control Valves .....	9-10
9.8.10 Instrument Racks .....	9-11
9.8.11 Tubing Systems.....	9-11
<b>9.9 CONTROL SYSTEM LOOP COMPONENT DESIGN.....</b>	<b>9-11</b>
9.9.1 Gas Turbine Generator (GTG).....	9-12

9.9.2	Steam Turbine Generator .....	9-13
9.9.3	Heat Recovery Steam Generator (HRSG).....	9-13
9.9.4	Feedwater System .....	9-14
9.9.5	Circulating Water System .....	9-15
9.9.6	Water Treatment Systems .....	9-15
9.9.7	Fuel Gas Metering and Conditioning System .....	9-15
9.9.8	Plant Systems – Raw Water .....	9-15
9.9.9	Plant Monitoring System .....	9-16
<b>9.10</b>	<b>HISTORICAL DATA STORAGE AND RETRIEVAL.....</b>	<b>9-16</b>
<b>9.11</b>	<b>CONTINUOUS EMISSIONS MONITORING SYSTEMS.....</b>	<b>9-16</b>
<b>9.12</b>	<b>ONLINE PERFORMANCE MONITORING SYSTEM .....</b>	<b>9-18</b>
<b>SECTION 10.0</b>	<b>- TRAINING .....</b>	<b>10-1</b>
<b>SECTION 11.0</b>	<b>- START-UP, INITIAL OPERATION AND PERFORMANCE TESTING .....</b>	<b>11-1</b>
<b>11.1</b>	<b>GENERAL .....</b>	<b>11-1</b>
11.1.1	SUMMARY:.....	11-1
11.1.2	QUALITY ASSURANCE: .....	11-2
11.1.3	SUBMITTALS: .....	11-2
11.1.4	ACCEPTANCE AND PERFORMANCE TESTS:.....	11-2
11.1.5	EXECUTION.....	11-2
11.1.6	1. Conditions Applicable to the Average Equivalent Availability test.....	11-19



## APPENDICES

A	ABBREVIATIONS.....	A-1
B	APPROVED VENDORS LIST .....	B-1
C	CONCEPTUAL SITE ARRANGEMENTS..... Site Plan Conceptual Combined Cycle Unit General Arrangement DA-101-1: Admin/Control/Warehouse Building Floor Plan	C-1
D	CONCEPTUAL PROCESS FLOW DIAGRAMS AND WATER BALANCE..... FD-1: Conceptual Process Flow Diagram WB-1: Conceptual Water Balance	D-1
E	CONCEPTUAL ELECTRICAL ONE - LINES .....	E-1
	SKE-1: Conceptual One Line Diagram	
F	PACIFICORP - "Material Specification ZS 001-2004, Substation Equipment – Power Transformer All Ratings" .....	F-1
G	GEOTECHNICAL REPORT .....	G-1
	Lake Side Preliminary Geotechnical Investigation Results	
H	LARGE GENERATION INTERCONNECTION AGREEMENT (LGIA) .....	H-1
I	MAKEUP WATER ANALYSIS (For Information) .....	I-1
J	FUEL ANALYSIS.....	J-1
K	DATA TO BE SUBMITTED WITH BID .....	K-1

# SECTION 1.0

## PROJECT SUMMARY

### 1.1 INTRODUCTION

#### 1.1.1 General Project Description

The Lakeside Power Project is being developed by PacifiCorp (Owner) in the City of Vineyard, Utah. The generating plant will include 2 X 1 combined cycle power plant capable of a nominal net output of 500 MW at the base load design ambient conditions.

The plant shall consist of two natural gas-fired GE Frame 7-FA or Siemens-Westinghouse 501F combustion turbine generators (CTGs) equipped with dry low NO<sub>x</sub> combustors and evaporative inlet air coolers. Exhaust gas from each of the CTGs shall be directed into a dedicated supplementary-fired heat recovery steam generator (HRSG) for the generation of high-pressure, intermediate-pressure, and low-pressure steam. Contractor shall optimize the design of the plant based on rated output, heat rate, and parasitic energy costs. This optimization shall include evaluation of economically attractive equipment such as natural gas preheater, HRSG duct firing and GTG output. Supplementary firing capability and power augmentation through steam injection shall be provided at Bidder's discretion in each HRSG to generate additional steam for peak power production. The steam generated in the HRSGs shall be supplied to a single, tandem-compound, reheat double downflow exhaust, steam turbine generator.

Contractor shall supply the combustion turbine/generators and the steam turbine/generator. The combustion turbine/generator and steam turbine/generator scope of supply is defined in this specification.

Exhaust steam from the steam turbine shall be condensed in a water-cooled surface condenser. Circulating water will be supplied to the condenser from a circulating water system using a cooling tower.

The GTGs will be equipped with dry low-NO<sub>x</sub> combustors. Each of the HRSGs shall have a selective catalytic reduction (SCR) system to further control NO<sub>x</sub> emissions and an oxidation catalyst for carbon monoxide (CO) and volatile organic compounds (VOC) emissions control. The CTGs and HRSG duct burners, if provided, will burn only natural gas.

The gas turbines, HRSGs, and all other major equipment, except for the steam turbine generator, shall be installed outdoors. The gas turbines will be installed in dedicated enclosures furnished with the equipment. A building shall be provided to enclose the steam turbine and shall include an overhead crane for maintenance. The existing administration building / warehouse provided under Block 1 shall be shared by both plants. Dedicated Air compressors shall be provided for Block 2 as required. Boiler feed pumps shall be provided in an enclosed, heated/ventilated, building with a monorail as required for maintenance. Other areas shall be as defined in the following specifications.

Power produced by the generators will pass through step-up transformers for delivery to the electrical transmission grid through a 345 kV switchyard.

The facility will be fueled solely by natural gas. Contractor scope under these specifications shall include pipe installation from the interface location on the existing metering station, conditioning, and delivery of fuel to the combustion turbines and HRSGs. Contractor scope will provide for technical coordination and support required to interface with the gas company as described in these specifications.

Contractor shall tie into the existing plant potable water system. Water for cooling tower make-up, process and non-potable uses will be Contractor's responsibility to supply. The piping and tie-in to the existing systems shall be by Contractor.

Process wastewater from the HRSGs and combustion turbine generator (CTG) evaporative coolers will be collected and routed to the cooling tower basin. HRSG hot drains, circulating water system blowdown, and water treatment system waste water shall be routed to the Lindon Hollow discharge. Sanitary wastewater shall be combined with the oil/water separator discharge and connected to the existing City of Lindon sewer system.

### **1.1.2 Specifications**

The purpose of the Technical Specifications is to define the minimum scope, plant features, and quality standards for the design, procurement, construction, startup and testing of the combined cycle power plant to be provided by Contractor on a turnkey basis.

Owner has prepared a conceptual plant design for the purpose of permit applications and specifying the minimum scope and features of the facility. The conceptual design includes heat balances, process flow diagrams, one-line diagrams, general arrangement drawings, and water balances. The conceptual design is included in Appendix C through Appendix E as a part of the specification. Contractor shall verify all aspects of the conceptual design and shall provide final design and detailed specifications, calculations and drawings as required for a complete and fully operational plant in conformance with the technical specifications. See Process Flow Diagram FD-1 included in Appendix D for a basic overview of the steam cycle.

Contractor shall utilize Vendors from Appendix B – Approved Vendors List whenever applicable. For the equipment listed, alternate vendors may be used with Owner approval only.

## **1.2 OVERALL SCOPE DESCRIPTION**

### **1.2.1 General Scope**

Contractor shall design, procure, fabricate, install, test, and commission a complete, functional, operating, power plant facility as specified herein with a high degree of reliability, integrity, maintainability, efficiency, and environmental compatibility which conforms to normally accepted standards for utility owned power generating facilities.

Except as specified otherwise, provide all equipment, materials, transportation services, labor, labor supervision, technical field assistance, scheduling, consumables, construction equipment, construction tools, special tools, construction utilities, permanent utilities, testing services, spare parts, and other services and items required

for, or incidental to the engineering, design, procurement, installation, construction, startup, testing, commissioning, and training for the facility.

Design, fabricate, install, inspect, examine, and test each system in accordance with the specified industry standards and applicable Laws. Comply with all requirements of the Applicable Laws and Applicable Permits as specified in the Contract.

Perform specified, code required, and Contractor's standard quality assurance testing, inspection, examination, and documentation.

Submit design, fabrication, and quality assurance documentation, and operating and maintenance manuals in accordance with the submittal requirements of Section 4.0 of these Specifications.

Except as specified otherwise, provide all transportation services required to transport equipment and materials from point of manufacture or point of origin to the Project Site and provide transportation on the Project Site to the area of installation as required to erect the equipment complete. Transportation services shall include supply and installation of any temporary or permanent transportation facilities required on or off Site as required to facilitate the delivery (i.e., road improvements and the like).

Except as specified otherwise, provide all technical assistance, equipment, and supplies required, specialized and non-specialized, for erection, testing, start-up, and commissioning of all components of the facility including those supplied by the Owner.

Coordinate start-up and commissioning operations with Owner's operating maintenance personnel and involve Owner's personnel in start-up and commissioning activities to the extent desired by the Owner.

Train Owner's operators and maintenance personnel on all operating and maintenance aspects of the facility prior to system start-up in accordance with Section 10.0 of this Exhibit A of the contract

Provide all planning, coordination, arrangements for leasing temporary equipment, installation of temporary equipment and commissioning of the project.

Fire protection during plant construction shall meet the requirements of NFPA 241. All fire protection systems shall be subject to the review and approval of the state and local fire department authorities.

Provide all special tools and lifting devices for equipment supplied by the Contractor as required for maintenance and operations for the intended life.

Contractor shall complete all information requested in Appendix K – Data to be submitted with Bid and turn in as a part of Contractors proposal

### **1.2.2 Work by Others**

Others will be performing work at the Site as part of this Project. Work by Others includes the following:

1. 345 kV switchyard supply and installation, 345 kV overhead line, and high voltage connection to step-up transformers; Power and control termination cabinets located in the switchyard control building; Contractor to supply dead-end

structures. Contractor shall be responsible for applying for securing, and executing the terms of all transmission Interconnect Agreements.

Contractor shall coordinate with other contractors as required to avoid interference in operations, conduct operations to minimize inconvenience to these contractors, and confine operations to areas within the Contract limits. Construction laydown and parking areas shall be provided for these other contracts and shall be shared with these contractors.

### **1.2.3 Terminal Points**

Boundaries associated with Contractor's scope of work for the Project are defined in the following paragraphs. Contractor shall coordinate with all other contractors to fully define interface requirements and shall provide all facilities as defined and as required to provide a fully functional plant including interface with off-site systems provided by Others.

#### **1.2.3.1 345 kV Switchyard**

Earthwork: Contractor will coordinate with switchyard contractor for finish grading, surfacing, and roadway requirements.

Generated Electrical Power: Contractor shall provide all facilities from the GSU high voltage bushings and including the generator step-up transformer, including 345 kV dead-end structure as required to generate electricity and transform it to 345 kV.

Switchyard Control, Relaying and Metering Interface: Switchyard contractor will provide a terminal cabinets located inside the switchyard control building for control, relaying and metering interface between the 345 kV switchyard and the power plant. Contractor shall provide all facilities required for control, relaying and metering interface on the power plant side of the switchyard junction box, including but not limited to, duct bank, wiring, programming, controls, and relaying and metering equipment.

RTU Communications: Switchyard contractor will provide an RTU (remote terminal unit) located in the switchyard control building. Fiber connections shall be made directly to the RTU from the plant DCS. Points not available in the DCS shall be hardwired directly to RTU. Contractor shall provide all facilities required for RTU communications on the power plant side, including but not limited to, duct bank, wiring, programming, and remote input/output interface equipment.

Grounding: Contractor shall extend plant-grounding system at two locations per generator step-up transformer for connection to the switchyard grounding system by the switchyard contractor. Contractor shall connect fence grounding at all interfaces with the switchyard fence. Contractor shall extend ground system at a minimum of four locations to connect to the existing ground system.

Fencing: All fencing surrounding the switchyard will be provided by the switchyard contractor. Contractor shall provide all other fencing and gates for the facility as required for Block 2 construction.

#### **1.2.3.2 Natural Gas**

Pipeline: Contractor shall connect to the existing Block 1 gas metering station for the supply of natural gas to Block 2 as indicated on the site plan. Provide all facilities

downstream of this connection required by these Specifications, including but not limited to, pressure regulation, moisture scrubbers, gas heating, filters/separators, cathodic protection, and piping.

#### 1.2.3.3 Water Supply

Pipeline: Contractor shall tie into an existing plant potable water system. Contractor shall provide all facilities down stream of this tie in point as required by these specifications, including but not limited to, a backflow preventer.

Contractor shall tie fire water system into existing Fire Water System.

#### 1.2.3.4 Process and Sanitary Waste Water Discharge

CTG wash water shall be collected in separate covered drain sumps which shall be provided with hose connections for truck disposal. Equipment/floor drains shall be routed to an Oil/Water Separator. Process water from the Oil/Water Separator, boiler blowdown, water treatment backflush cooling tower blowdown, and excess condensate shall be routed to Lindon Hollow discharge. Process waste water will be segregated from sanitary waste and the oil/water separator effluent. Sanitary waste and treated effluent from oil/water separator will be combined and discharged to the City of Lindon's sewer system.

Contractor shall provide all facilities upstream of this tie-in point required by these specifications, including but not limited to, collection of sanitary wastewater within the facility, routing of the wastewater to the tie-in point, and a sanitary wastewater flow meter.

#### 1.2.3.5 Telephone and Data Communications

Communications: Telephone and data communication systems for the facility will be furnished and installed by the Contractor. The telephone and data communications system will be inter-connected with the systems already existing for the Block 1 plant. The new systems shall be compatible with those already installed. Provide panel boards in the administration building for connection by the telephone and data communications service provider. Provide all facilities, including but not limited to, wiring, jacks, switches, controls, and phones, on the plant side of the communications panels as required to provide a complete and functional plant communications system for both telephone service and data communications service.

Provide a conduit system from site interface point (to be identified later on General Arrangements) to the location of the panel boards for installation of the communications wiring by others.

### **1.2.4 Owner Furnished Equipment and Systems**

The following equipment will be directly purchased by Owner:

1. 345 kV Switchyard - Owner will directly contract the plant switchyard supply and installation and electrical interconnection to the utility grid with Others. Contractor shall be responsible for applying for securing, and executing the terms of all transmission Interconnect Agreements.

2. Permanent Plant Spares – Owner will provide permanent plant spare parts as required to maintain an operating plant after plant start-up. Contractor shall supply all spare parts required to start-up the facility through Substantial Completion. Contractor shall provide a list of recommended permanent spare parts including unit price, pricing validity timeframe, quantity, description, OEM and OEM part number. The spare parts list shall include a list of all spare parts anticipated for three years of operation.

## 1.2.5 Noise Levels

### 1.2.5.1 Equipment Noise Requirements

1. Each Combustion Turbine Generator shall be purchased to meet near field noise requirements of 85 dBA when measured 3 feet in the horizontal plane from the equipment (or enclosure) in any direction and 5 feet from the ground or any personnel platform (without additional attenuation outside OEM scope).
2. The Steam Turbine Generator shall be purchased to meet near field noise requirements of 90 dBA when measured 3 feet in the horizontal plane from the equipment (or enclosure) in any direction and 5 feet from the ground (without additional attenuation outside OEM scope).
3. As a minimum, each HRSG shall be guaranteed to meet 67 dBA when measured 100 feet in the horizontal plane from the HRSG (or enclosure) in any direction and 5 feet from the ground.
4. As a minimum, each Transition Duct shall be guaranteed to meet 67 dBA when measured 100 feet in the horizontal plane from the transition duct in any direction. Attenuation, if required, from the CTG exhaust expansion joint through the HRSG transition duct shall be in Contractor's scope.
5. As a minimum, each HRSG exhaust stack shall be guaranteed to meet 56 dBA when measured 100 feet in the horizontal plane from the HRSG exhaust stack in any direction and 5 feet from the ground.
6. As a minimum, Contractor shall procure all engineered equipment with vendor guaranteed near field noise levels of 85 dBA when measured 3 feet in the horizontal plane from the equipment (or enclosure) in any direction and 5 feet from the ground or any personnel platform. Contractor shall make all reasonable efforts to enforce this criteria.
7. Contractor shall enforce all guarantees to correct equipment which is out of compliance.

Based upon a post construction noise survey completed by Contractor, Contractor shall post noise warning signs in all areas determined to exceed 85 dBA. Sound level measurements shall be made with a sound level meter that meets the requirements of the latest revision of ANSI S1-4 Type 1 or better. Sound level meter must be calibrated to within +/- 1 dB at the beginning and end of each measurement period. Measurements are to be performed in accordance with ANSI S12-23-1989 and S12-36-1990 for the near field. Exceedance areas must have Owner approval.

### 1.2.5.2 Indoor Noise Limits

Noise levels in normally occupied work areas, such as office and control room areas, shall be limited to 45 dBA.

### 1.2.5.3 Far Field Noise Guarantees

The far field noise levels shall not exceed guarantee limits at site boundaries as required by Federal, State, and local regulations. Far field noise guarantees must be met during all startup, operating, (including full bypass operation), shutdown, and trip conditions. Sound level measurements shall be made with a sound level meter that meets the requirements of the latest revision of ANSI S1-4 Type 1 or better. Sound level meter must be calibrated to within +/- 1 dB at the beginning and end of each measurement period. Far field noise measurements are to be performed in accordance with ANSI S12.9-1993 and ANSI S12.18-1994.

### **1.2.6 Mechanical Scope**

The Mechanical Scope is summarized below and requirements are more fully described in Section 5 of this specification.

Contractor shall supply all equipment and systems necessary for a complete and fully functional facility. The equipment and systems to be provided shall include, but shall not be limited to, the following:

1. Combustion Turbine Generators (CTGs)
2. Steam Turbine Generator (STG)
3. Heat Recovery Steam Generators (HRSGs)
4. HRSG Vents and Drains
5. Steam System (including bypass system)
6. Condenser (including vacuum system)
7. Condensate System
8. Feedwater System
9. Cooling Tower
10. Circulating Water System
11. Service Water System
12. Process Make-up Water System
13. Closed Cooling Water System
14. Potable Water System
15. Fire Protection System
16. Aqueous Ammonia Storage and Transfer System
17. Chemical Treatment and Injection System



18. Sampling System
19. Bulk Gas Storage System
20. Fuel Gas System
21. Instrument/Service Air Systems
22. Heating, Ventilating, and Air Condition (HVAC) System
23. Plant Blowdown System
24. Plant Drains System
25. Wastewater Collection and Disposal (including oily wastewater)
26. All Miscellaneous Mechanical Systems and Equipment
27. All temporary facilities and systems needed to implement this work

### **1.2.7 Electrical Scope**

The Electrical Scope is summarized below and requirements are more fully described in Section 8 of these specifications.

Contractor shall supply all equipment and systems necessary for a complete and fully functional facility. The equipment and systems to be provided shall include, but shall not be limited to, the following:

1. Generator Step-up and auxiliary Transformers
2. Low Side Generator Breakers
3. Isolated phase Bus Duct System
4. Power supply to the circulating water system
5. Medium-Voltage System including switchgear and MCC's
6. Low-Voltage System including switchgear and MCC's
7. Direct Current (DC) Power System
8. Uninterruptible Power Supply (UPS)
9. Communication System expansion
10. Security System expansion
11. Lighting
12. Grounding

13. Cathodic Protection
14. Heat Tracing
15. Lightning Protection
16. All Miscellaneous Electrical Systems and Equipment

### **1.2.8 Instrumentation and Control Scope**

The Instrumentation and Controls Scope is summarized below and requirements are more fully described in Section 9 of these specifications.

1. Fully Integrate Block 2 Control Room equipment into existing Block 1 Central Control Room utilizing equipment and programs similar to those used on Block 1
2. Distributed Control Systems and PLCs
3. Recording devices and Historians. Interface as required for connection to Owner's PI Data Historian.
4. Hard-Wired Emergency Trips and Critical Interlocks
5. Fuel Gas Regulating and Metering Systems
6. Continuous Emission Monitoring Systems
7. Performance Monitoring System
8. Instrumentation and Control Devices

### **1.2.9 Civil Scope**

The Civil Scope is summarized below and requirements are more fully described in Section 6 of these specifications.

1. Geotechnical Investigations
2. Topographic and Construction Surveys
3. Site Preparation
4. Permanent Site Drainage and Erosion Control
5. Drainage and Erosion Control During Construction
6. Construction Stormwater Disposal
7. All Sub-grade Work and Foundations
8. All Final Grading

9. Roads and Paving including Parking Areas
10. Plant Site Fencing and Gates

### **1.2.10 Structural and Architectural Scope**

The Structural and Architectural Scope is summarized below and requirements are more fully described in Section 7 of these specifications.

1. Structural Materials
2. Concrete
3. Steam Turbine-Generator Building
4. Overhead crane
5. Steel including Pipe Racks and Supports
6. Siding and Roofing
7. Miscellaneous Buildings
8. Water Sample Laboratory
9. Painting

### **1.2.11 Construction Facilities and Services**

#### **1.2.11.1 Coordination**

Contractor shall furnish and maintain temporary construction facilities and provide construction services including, but not limited to, the following:

1. Temporary Storage and Parking Facilities - Contractor shall provide facilities at the Site for the proper unloading and storage of all plant material delivered to the Site. Available laydown and parking space is indicated on the General Arrangement Drawing in Appendix C.
2. Contractor to provide all permits required for construction.
3. Construction Power and Distribution –Contractor shall be responsible for all electric power tie-ins at the Site.
4. Temporary communication system
5. Temporary lighting system
6. Site drainage, sedimentation control, and dewatering systems
7. Temporary roads
8. Fire protection service (until Substantial Completion)

9. Construction sanitary facilities including construction offices
10. Temporary water supply (potable and not potable) Potable water shall be high quality bottled water.
11. Parking Facilities – Contractor shall develop parking facilities to accommodate all construction work forces as indicated on the General Arrangement Drawing in Appendix C.
12. Site Security - Contractor shall be responsible for providing the fencing, guarding, and watching the Site including all construction office trailer, construction parking, and laydown areas as necessary for protection during construction (until Substantial Completion).
13. Construction testing services (e.g. weld NDE, hydrotesting, megger testing, concrete strength and placement, compaction testing, steel testing etc.).
14. Construction Materials - Contractor shall supply all the equipment, tools, consumables, instruments, etc., necessary for the construction and erection of the plant. The supply of the construction equipment shall include fuel, lubricants, startup chemicals, spare parts, and any other elements or service required for operation and maintenance.
15. Site environmental compliance and protection - Contractor shall implement and enforce all applicable laws and regulations on construction related activities.
16. First Aid Services - Contractor shall provide onsite first aid services in conjunction with arrangement for offsite first aid transportation and treatment as necessary during the construction of the plant.
17. Temporary Construction Facilities at the site to support Contractor's construction staff and labor force, and the delivery, unloading and storage of equipment and materials.

#### 1.2.11.2 Coordination

Contractor and any other parties involved in the construction of the project shall attend such pre-construction and construction meetings as may be requested by Owner. At the initial meeting, Contractor shall present a construction plan including, but not limited to, the following: safety, procurement plan, major equipment receipt plan, construction sequence, methods and equipment to be used in all phases, tentative access and right-of-way roads, locations of staging areas, regrading of roads, moving of equipment/property that will interfere or impact construction and a construction schedule showing all activities for the entire construction phase of the project. All construction related activities shall be in compliance with PacifiCorp's "Construction Coordination Agreement".

Contractor shall be responsible for contacting all involved utility companies prior to starting any work to determine schedule of work and location of all temporary and permanent facilities in the project area.

Contractor shall prepare an outage plan for all scheduled interruptions of electrical power or other utilities-interference that would affect third parties. This plan shall be

submitted by Contractor to Owner and the affected parties at least thirty (30) days prior to outage.

Representatives of Contractor shall attend weekly coordination meetings to discuss matters relative to the progress and execution of the construction and startup of the project. Current week progress and three-week look ahead schedules shall be presented by the Contractor and reviewed at these meetings in addition to other site coordination items.

#### 1.2.11.3 Safety

Contractor shall implement and maintain, throughout the construction period, a written safety and accident prevention program which meets the requirements of federal, state, and local codes and regulations, and all other authorities having jurisdiction over this work. Subcontractors and vendor-supplied service organizations will each be required to implement a safety program commensurate with the work to be performed and in compliance with Contractor's Site Safety Plan.

Contractor's Safety, Health, and Accident Prevention Program shall be submitted to Owner for approval and shall include disciplinary procedures and safety orientation training procedures applicable to Contractor and his subcontractor personnel. Special emphasis shall be applied to ensure the use of personal safety equipment and strict adherence to fall protection standards.

Contractor shall include a qualified on-site health, safety and security coordinator who, unless otherwise approved by Owner in writing, shall have no other duties. The health and safety coordinator shall be on-site during all hours of construction and shall have authority to:

1. Identify unsafe conditions or practices to Construction management for correction.
2. Instruct Construction management when a work stoppage is necessary to correct an unsafe act or condition. Work with Construction management to develop a safe work approach to correction unsafe site conditions.
3. Investigate and respond to Owner identified safety concerns.

Contractor shall hold regular scheduled safety meetings to instruct his personnel and subcontractor personnel in safety and health practices. Contractor shall maintain accurate accident and injury reports and shall furnish Owner a monthly summary of injuries and man-hours lost due to injuries and copies of all accident and injury reports.

#### 1.2.11.4 Security

Contractor shall prepare and implement a Site Security Plan. Contractor shall cooperate with Owner on all security matters. A copy of the Site Security Plan shall be provided to Owner.

#### 1.2.11.5 Fire Protection

Only work procedures which minimize fire hazards to the extent practicable shall be used. Combustion debris and waste materials shall be collected and removed from the site each day. Fuels, solvents, and other volatile or flammable materials shall be stored

away from the construction and storage areas in well marked, safe approved containers. Good housekeeping is essential to fire prevention and shall be practiced by Contractor throughout the construction period. Contractor shall follow the recommendations of the AGC "Manual of Accident Prevention in Construction" regarding fire hazards and prevention.

Formwork, scaffolding, planking, and similar materials which are combustible but which are essential to execution of the work shall be protected against combustion resulting from welding sparks, cutting flames, and similar fire sources.

Contractor shall provide qualified personnel for fire control as appropriate. Contractor shall provide adequate fire protection equipment in each warehouse, office and other temporary structures, and in each work area that he is occupying. Access to sources of firewater shall be kept open at all times. Suitable fire extinguishers shall be provided in enclosed areas, in areas that are not accessible to fire water, or in areas that may be exposed to fire that cannot be safely extinguished with water. Each fire extinguisher shall be of a type suitable for extinguishing fires that might occur in the area in which it is located. In areas where more than one type of fire might occur, the type of fire extinguisher required in each case shall be provided. Each extinguisher shall be placed in a convenient, clearly identified location that will most likely be accessible in the event of fire.

Contractor alone shall be responsible for providing adequate fire protection of the construction areas. Failure of Contractor to comply with, or Owner or Owner's Engineer to enforce, the above requirements shall not relieve Contractor from any responsibility or obligation under this Contract.

#### 1.2.11.6 Cleanliness

Contractor shall keep Project Site free at all times from accumulations of waste materials and rubbish. Special attention shall be given to keeping the structures and surrounding grounds clean and free from trash and debris. Contractor shall require all disciplines to thoroughly clean their work areas each working day. Contractor's Construction Manager shall be responsible for Site maintenance and cleanliness. This shall include sweeping the floor, collecting and disposing of trash, and all other functions required to keep the site clean. All hoses, cables, extension cords, and similar materials shall be located, arranged, and grouped so they will not block any accessway and will permit easy cleaning and maintenance.

A roll-up of all hoses, welding leads and electrical cords will be executed once a month as a minimum or as determined by site management. Material and equipment not required for immediate use or installation will be stored in designated laydown and warehouse areas.

All trash, debris, and waste materials shall be collected, sorted, and deposited in waste collection receptacles near the work. These receptacles shall be emptied regularly and the waste properly disposed of off-site.

Promptly upon the completion of a construction task, Contractor shall thoroughly clean the equipment or structure affected by the task activity by removing all accumulations of dirt, scraps, waste, oil, grease, weld splatter, insulation, paint, and other foreign substances. Contractor, without additional cost or burden to Owner, shall properly and

adequately restore surfaces damaged by deposits of insulation, concrete, paint, weld metal, or other adhering materials.

#### 1.2.11.7 Signs and Barricades

All signs and barricades shall be provided and maintained by Contractor and shall be in accordance with jurisdictional regulations for accident prevention.

#### 1.2.11.8 Dust Control

Contractor shall be responsible for dust control at the Site. Contractor shall prevent the spread of dust during its operations. Contractor shall moisten all surfaces with water to reduce the risk of dust becoming a nuisance to the public and neighbors. Contractor shall furnish all labor and equipment necessary for dust control including tank trucks and hoses to apply Owner furnished water. Contractor shall conform to all requirements of the Applicable Permits.

#### 1.2.11.9 Open Burning

On Site open burning will not be permitted.

#### 1.2.11.10 Cooperation with Other Contractors

During the process of the work, it will be necessary for other contractors to be present on or about the site. Contractor shall afford all reasonable cooperation to such other contractors.

Contractor, if required, shall exchange with other contractors furnishing associated equipment, all necessary drawings and other information required to be furnished under the specifications of the respective contracts. Three (3) electronic copies of all drawings and correspondence relating to information exchanged between Contractor and other contractors shall be sent to Owner.

#### 1.2.11.11 Energized Facilities

Contractor may encounter at the site existing energized facilities, operating machinery, and systems, which must remain energized and functional during the execution of the work.

Contractor shall be completely responsible for the safety and protection of his personnel, Owner's personnel, and the public on the site of the Work and shall employ all methods necessary to achieve such safety and also assure continuity of all service systems encountered. These methods shall include, but not be limited to, providing barriers, guard structures, insulating guards and sleeves, warning signs, and prevention of unauthorized access to service system areas.

#### 1.2.11.12 Reference Points

Contractor shall establish baselines, monuments, and reference points for construction as necessary to proceed with layout of the work. Contractor shall be responsible for laying out the work to such lines and grades indicated on the drawings, and shall protect and preserve the established reference points, subject to changes as Owner may direct.

#### 1.2.11.13 Dangerous Materials

Contractor shall not use explosives, radioactive, or other dangerous material without prior notification to and approval by Owner. Contractor shall be responsible for the proper handling, transporting, storage, and use of such materials. When the use of such materials or methods is necessary, Contractor shall exercise the utmost care and carry on such activities under supervision of its properly qualified personnel. Contractor, at its expense, shall repair any damage caused by its handling, transporting, storage, and use, and shall be responsible for obtaining permits as applicable.

#### 1.2.11.14 Waste Disposal

Contractor shall be responsible for removal and lawful disposal of all discarded material, debris, rubbish, unusable excavated material, chemical cleaning disposal and all other waste, including hazardous substances, if any, generated by Contractor and its subcontractors and suppliers during construction of the plant. Contractor shall not be liable for nor required to remove any hazardous waste on or under the Site on the effective Notice-to-Proceed date or waste brought on by Owner thereafter or generated by operation of the plant.

#### 1.2.11.15 Hazardous Material Management

Contractor shall be responsible for managing hazardous materials and hazardous wastes. Contractor shall be responsible for designating and managing storage areas, preparing plans, obtaining necessary permits, record keeping and reporting requirements in compliance with applicable, local, state and federal regulations. Owner will obtain an EPA I.D. Number to be used for manifesting hazardous waste.

#### 1.2.11.16 Adjoining Utilities

Contractor shall make necessary efforts to protect any and all parallel, converging, and intersecting electric lines and poles, telephone lines and poles, highways, waterways, railroads, and any and all property from damage as a result of its performance of the work. Contractor shall bear all liability for and shall at its expense repair, rebuild or replace any property damaged or destroyed in the course of its performance of the work.

### **1.2.12 Production Inputs**

Owner will provide the following Production Inputs:

1. Fuel gas for startup and commissioning of the plant, with quality as indicated in Appendix J
2. Water for construction and commissioning of the plant with quality and quantity as indicated in Appendix I. Water required for construction and commissioning in excess of those quantities shall be provided by Contractor.
3. Electricity input into the plant for startup and commissioning of the plant from the auxiliary transformers or backup power source. Construction power shall be provided by Contractor.



Contractor shall provide the following Production Inputs:

1. All Chemicals including, but not limited to, water treatment chemicals, boiler treatment chemicals, ammonia, and ethylene glycol for operation of systems during startup and commissioning of the plant. Owner will select supplier and coordinate purchase of these items. However, costs will be charged to the Contractor's account.
2. All Gases including, but not limited to Nitrogen, Carbon Dioxide, Hydrogen, and CEM gases for operation of systems during startup and commissioning of the plant.
3. Lube oils necessary for flushing and operation of systems during startup and commissioning of the plant. Owner will coordinate purchase of these items. However, costs will be charged to Contractor's account.

#### **1.2.13 Operating Consumables**

Until Substantial Completion is reached, Contractor shall provide (at Contractor's cost) all Operating Consumables, including initial fill and other consumables required for preparation, startup, and commissioning of the power plant including but not limited to the following:

1. Demineralized water
2. Water Conditioning Chemicals
3. Aqueous Ammonia
4. Grease
5. Lubricants
6. Chemicals required during construction of the plant (such as boiler chemical cleaning chemicals)
7. Purging Gases
8. CEMS gases
9. Filters
10. Strainers
11. Spare parts such as gaskets, filter cartridges, light bulbs, lamps, fuses, etc.

Contractor shall top off all tanks and fire protection equipment shall be filled at Substantial Completion.

### 1.3 PLANT OPERATING PROFILE

#### 1.3.1 Plant Load Definition

For the purpose of these specifications, the following plant load definitions shall be used for the Power Block.

Load Point	Gas Turbine Output	HRSG Output	Steam Turbine Output
Peak	2 @ Base Load	Maximum Duct Burning & power augmentation (if provided)	Turbine Follow/Sliding Pressure
Base	2 @ Base Load	No Duct Burning	Turbine Follow/Sliding Pressure
Minimum	1 @ 50% Base Load or OEM operating minimum	No Duct Burning	Turbine Follow/Pressure Control
Bypass	2 @ Base Load	No Duct Burning	Steam Turbine Bypassed

#### 1.3.2 Plant Operating Profile

Operating conditions are expected to vary seasonally with periods of cyclic operation to minimum load or shutdown at night and periods of base load operation with daily duct firing for peak operation above 80°F ambient temperatures

Contractor shall provide a plant designed to operate continuously at all load conditions between Minimum and Peak operation as indicated above and meeting all the requirements of the Contract, and operating within the limits of all Applicable Permits at any operating point within this range.

Annual plant starts to be utilized for design are as follows:

Cold (> 72 hour shutdown)	12
Warm (24-72 hour shutdown)	55
Hot (< 24 hour shutdown)	263

Contractor shall provide a system designed to start-up, shutdown, and operate as required and within the time frames specified in Exhibit I of the Contract.

Contractor shall provide a plant designed to allow continuous bypass operation as defined above, with all steam being bypassed around the steam turbine to the ACC system and without any steam being vented to the atmosphere. Plant shall be capable of full bypass operation while allowing Owner to work on non-operating unit (except STG).

### **1.3.3 Plant Operating Philosophy**

Design plant with suitable equipment, automation, and controls to allow plant to start-up, operate normally at any load between Minimum load and Peak load, and shutdown with one operator in the control room and one operator in the plant. Provide plant with suitable automation consistent with the requirements.

### **1.3.4 Plant Reliability**

In general, provide a plant with full redundancy of all equipment and systems prone to failure that are required to support operation of the plant in Base Load operation and all equipment or systems for which a failure during any operation (Minimum, Base, Peak, or anywhere in between) could result in damage to the equipment or to the system.

Provide redundancy of equipment and systems required to support operation of the plant in Peak Load operation only where specified in this Exhibit A. Where redundant (standby) equipment is supplied, the idle component shall be capable of automatic and immediate initiation into operation upon failure of one or more of the operating components. Necessary instrumentation shall be supplied to sense a failure of one or more of the operating components.

### **1.3.5 Plant Performance**

Contractor shall design the plant to optimize performance (output and heat rate) at the Plant Design Base Load conditions with capability of operating at all other design loads between the Minimum and Peak Loads.

Design plant to provide Guaranteed Peak output at the Plant Guarantee Peak Load conditions indicated in Table 2-1. Plant emissions must meet limits established in the air permit.

## SECTION 2.0 SITE DESIGN CONDITIONS

Specific site design conditions are summarized in Table 2-1.

**Table 2-1  
Site Design Conditions**

Plant Design Base Load Ambient Conditions: (Average Ambient Dry Bulb Temperature/ Coincident Wet Bulb Temperature)	95°F DBT 66°F WBT
Plant Design Peak Load Ambient Conditions: (Average Peak Dry Bulb Temperature/Coincident Wet Bulb Temperature)	95°F DBT 66°F WBT
Maximum Ambient Design Conditions: (Maximum Dry Bulb Temperature/Coincident Wet Bulb Temperature)	105°F DBT 64°F WBT
Minimum Ambient Design Conditions: (Minimum Dry Bulb Temperature/Coincident Relative Humidity)	-16°F DBT -16°F
Elevation	4500 ft above mean sea level
Location	Vineyard, Utah
Seismic Criteria	See Section 7.2.4 of Exhibit A
Wind Design	See Section 7.2.3 of Exhibit A
Precipitation	
Average Annual Precipitation	13.0 in. *
Maximum 24 hr Precipitation	2.04 in. *
Average Annual Snowfall	23.9 in.*
Maximum 24 hr Snowfall	12.5 in.*
Design Maximum Rainfall Rate	25 year/24 hour storm
Design Frostline:	As identified by local building code
Fuel	
Primary	Natural Gas
Backup	None
Preheating for starting	As specified by the gas turbine manufacturer. Minimum superheat 50°F.
Preheating for performance	As required by GTG Manufacturer
Supply Pressure at Owner interface point (regulation by contractor)	525-600 psig
* Data from the Western Regional Climate Center for Vineyard, Utah.	

### 2.1 GEOTECHNICAL CONDITION

A preliminary geotechnical study has been completed for the Lake Side Block 1 Project, which includes the Project Site property. This preliminary geotechnical study is

presented in APPENDIX G of this document and shall not be relied upon to provide necessary and sufficient geotechnical information for design. Contractor shall be responsible for performing any and all studies, investigations or other work necessary to provide sufficient and appropriate information for foundation design and site improvement considerations.

## **2.2 SITE SECURITY**

From the time of initial mobilization to Substantial Completion, Contractor is responsible for security and entrance to the power plant construction area, office trailer area, construction parking area, and laydown areas (Others will control access to switchyard areas). Security will include fencing areas as they come under construction and are completed, secured warehousing of plant equipment and materials and security guards, Contractor is responsible for controlling visitor access and site visits.

## **2.3 SITE ACCESS**

Contractor shall establish a temporary access point into the site and to any temporary staging / laydown areas, as required. Contractor shall construct and maintain access to laydown area(s). Laydown areas will be rough graded by Contractor. Any additional preparation required for the laydown areas shall be Contractor's responsibility. Contractor shall restore the laydown area to Owner's satisfaction upon completion of use.

Construction of the proposed facility will follow all permit requirements and engineering design specifications. Owner and/or his representatives will be onsite continuously to monitor that construction is in compliance with all permit and design specification requirements.

The plant shall be constructed without obstructing public thoroughfares. All warning and traffic signs shall be provided and maintained. A safe workplace environment shall be maintained.

The proposed facility site and roadway layout is shown on the site plan and general arrangement drawings.

Contractor is required to meet the safety requirements outlined in this Contract

## **2.4 SITE ENVIRONMENT**

Contractor shall be responsible for protecting and maintaining the site, which shall include but not be limited to the following:

Proper storage and disposal of all materials, waste and contaminants such as debris, paints, solvents, lubricants, oils, etc. will be required at all times. No materials, wastes or contaminants shall be disposed of on-site. Records of all disposals shall be retained and provided to Owner at the end of the project. Contractor must maintain MSDS information for all materials brought to the site. All waste must be handled in accordance with the applicable local, state, and federal regulations.

Contractor shall maintain the project site in a neat and clean condition at all times. Materials shall be protected from damage due to dirt, debris or the elements. Upon completion, all temporary buildings, rubbish, unused materials and other equipment and materials belonging to and used in the performance of the work shall be disposed of. During construction, storm water and fugitive dust emissions shall be controlled by use of proper construction practices or other suitable means.

## **SECTION 3.0**

### **CODES, STANDARDS, AND REGULATIONS**

The editions and addenda of the following Codes and Publications effective as of the effective date of the Contract shall apply to all work performed under this Contract.

AASHTO	American Association of State Highway and Transportation Officials
ABMA	American Boiler Manufacturer's Association
ACI	American Concrete Institute
AFBMA	Anti-Friction Bearing Manufacturers Association
AGA	American Gas Association
AGMA	American Gear Manufacturers Association
AISC	American Institute for Steel Construction
AISI	American Iron and Steel Institute
AITC	American Institute of Timber Construction
AMCA	Air Moving and Conditioning Association
ANSI	American National Standards Institute
API	American Petroleum Institute
ASCE	American Society of Civil Engineers
ASHRAE	American Society of Heating, Refrigeration and Air Conditioning Engineers
ASME	American Society of Mechanical Engineers
ASNT	American Society for Nondestructive Testing
ASTM	American Society for Testing and Materials
AWWA	American Water Works Association
AWS	American Welding Society
BOCA	Building Officials and Code Administrators International
CAGI	Compressed Air and Gas Institute
CMMA	Crane Manufacturers Association of America
CFR	Code of Federal Regulations
CTI	Cooling Tower Institute
DEP	Division of Environmental Protection
EEI	Edison Electrical Institute
EJMA	Expansion Joint Manufacturing Association

EPA	United States Environmental Protection Agency
FAA	Federal Aviation Agency, Department of Transportation
FED	Federal Standards
FM	Factory Mutual
HEI	Heat Exchange Institute
HI	Hydraulic Institute Standards
IBC	International Building Code
IEEE	Institute of Electrical and Electronics Engineers
IES	Illuminating Engineers Society
IMC	International Mechanical Code
IPC	International Plumbing Code
IPCS	Insulated Power Cable Society
ISA	Instrument Society of America
LPC	Lightning Protection Code
MBMA	Metal Building Manufacturers Association
MSS	Manufacturers Standardization Society of the Valve and Fittings Industry
NAAMA	National Association of Architectural Metal Manufacturers Metal Bar Grating Manual
NACE	National Association of Corrosion Engineers
NAFM	National Association of Fan Manufacturers
NBBPVI	National Board of Boiler and Pressure Vessel Inspectors
NIBS	National Bureau of Standards
NEC	National Electric Code
NEMA	National Electrical Manufacturers Association
NESC	National Electric Safety Code
NETA	National Electrical Testing Association
NFPA	National Fire Protection Association
NSF	National Sanitation Foundation
OSHA	Occupational Safety and Health Administration
PPI	Plastic Pipe Institute
PFI	Pipe Fabrication Institute
RMA	Rubber Manufacturers Association
SAE	Society of Automotive Engineers
SDIS	Steel Deck Institute Standards



SJIS Steel Joist Institute Standard  
SMACNA Sheet Metal and Air Conditioning Contractors National Association  
SSPC Steel Structures Painting Council  
TEMA Tubular Exchanger Manufacturers Association  
TIMA Thermal Insulation Manufacturers Association  
UBC Uniform Building Code  
UL Underwriter Laboratories Incorporated  
UMC Uniform Mechanical Code  
UPC Uniform Plumbing Code  
UUBSAR Utah Uniform Building Standard Act Rules, R156-56  
State of Utah Environmental Protection Agency  
PacifiCorp Document – “Construction Coordination Agreement”  
City of Vineyard Municipal Code  
Utah County Ordinances

Contractor shall obtain Owner approval for any deviations to these standards or alternative standards. Request for deviation or alternate shall include an explanation why such change is necessary and how compliance is to be achieved. Owner reserves the right to reject any such request for any reason. If Contractor discovers any conflict between any code, standard, or regulation, Contractor shall notify Owner of such conflict. Owner, in its sole discretion, shall then choose which provision shall take precedence over such conflicting provision. Unless specific exceptions are indicated in this contract, all specifications will be considered applying to all phases of the work.

## **SECTION 4.0**

### **ENGINEERING SCOPE**

#### **4.1 GENERAL REQUIREMENTS**

Contractor shall perform all design engineering work required for construction and startup of a fully functional facility including, as a minimum, the following items:

1. Prepare design documents, size equipment, generate drawings and specifications, and other supporting activities to the degree of detail required to fully and clearly define manufacturing and construction work requirements and minimizes design engineering work in the field.
2. Prepare calculations as required for design decisions, equipment and material selection, and preparation of construction drawings.
3. Prepare calculations as required for all concrete, steel, masonry, and other structural elements. Calculations shall contain element identification, loading, and support conditions.
4. Prepare system descriptions indicating equipment data, operating characteristics, functions, flow rates and other process information for all plant systems.
5. Prepare mechanical, electrical and instrument equipment lists with summary descriptions, vendors, and pertinent data.
6. Develop the detailed site arrangement including provisions for locations of structures, equipment and permanent access routes.
7. Develop and maintain a detailed electronic model of the plant.
8. Prepare arrangement drawings for Owner's Review and finalize arrangement drawings for construction.
9. Prepare Piping and Instrumentation Diagrams (P&ID's) for all Mechanical Plant Systems.
10. Provide all civil, electrical, instrument and control, mechanical, and structural construction drawings for the plant and supporting systems, including, but not limited to, the following:
  - A. Site Arrangement
  - B. Plant Arrangement
  - C. Control Room and Electrical Room Arrangements (modifications necessary for plant expansion)
  - D. Access Roads, Curbs, Walkways, and Parking
  - E. All grading
  - F. All Site Fencing

- G. All Drainage
  - H. Foundations and Equipment Pads
  - I. Ductbanks and Manholes
  - J. Structural Steel, Platforms and Stairs
  - K. Architectural Plans, Elevations and Details
  - L. Water and Wastewater Supply and Treatment Systems
  - M. Equipment Location Plans and Elevations
  - N. Yard Piping
  - O. Piping 2 ½ Inches and Larger
  - P. Steam Blow and Cycle Flush Piping
  - Q. Pipe Supports Including Hanger Designs
  - R. Conduit, Cable and Raceway
  - S. Fire Protection Systems
  - T. One-Line Electrical Diagram
  - U. Three-line Electrical Diagram (generator and auxiliary voltages only)
  - V. Underground Utilities and Yard Piping
  - W. Grounding and Lightning Protection
  - X. OEM Packages
  - Y. Lighting (excluding switchyard) and Communication
  - Z. Power and Control Wiring
  - AA. CEM Systems
  - BB. Instrument Location Plan and Installation Details
  - CC. Electrical Schematics and Interconnect Diagrams
  - DD. Instrumentation Lists, DCS Control Loops, Logic Diagrams, Conceptual  
Graphic Displays, etc.
  - EE. Motor List
11. Prepare technical specifications and other documentation to support all equipment procurement, materials, and construction requirements. Specifications must include all applicable supporting calculations.
  12. Implement project management and project controls to manage the work, control the schedule and budget for this project.
  13. Obtain necessary plan approvals and building permits from appropriate state, county and local building authorities. Fees to building authorities shall be paid by Contractor.

All design documents that are issued for construction or procurement shall be prepared by qualified project design team members as required by the State of Utah. Each engineer responsible for the design shall stamp or certify the design documents have been prepared by or under his direction. Such design documents shall include, but are not limited to, all purchase and construction specifications, arrangement drawings, elevations, structural drawings, civil drawings, foundation designs, P&ID's, equipment arrangements, piping layouts, pipe stress analysis, electrical three-line diagrams, and electrical one-line diagrams.

Structural design may utilize standard computer programs that have been verified by Contractor.

Owner reserves the right to review all engineering documents and records produced by Contractor at any time.

Upon completion of the project, Contractor shall provide to Owner an as-built technical engineering library including all engineering calculations, design documents, and other technical records produced by Contractor.

#### **4.1.1 Architectural Design**

Contractor shall provide architectural design for all buildings, areas, and spaces described in these specifications in accordance with the specifications and applicable code requirements.

Contractor shall provide architectural plans and sections for all buildings indicating general layout, permanent fixtures, finishes, and other architectural features.

Contractor shall review local codes and prepare preliminary conceptual drawings for review by regulatory bodies to obtain building permits, railroad easements, permits, etc. for construction related activities.

#### **4.1.2 Civil / Structural Design**

Contractor shall provide all design engineering and technical support for final arrangements, site grading, roads, site drainage, stormwater diversion channels, parking, site fencing and gates, final paving, site improvements, site utilities, and construction surveys within the site boundary.

Contractor shall:

1. Design yard piping and prepare yard-piping drawings.
2. Provide all design engineering for construction facilities including access roads, laydown areas, parking lots, drainage and construction utilities.
3. Provide analysis and detailed design for major plant equipment foundations.

4. Provide detailed design for structures including foundations and super-structures, concrete and reinforcing steel, structural steel, platforms, piperacks, stairs and enclosures, including appropriate design calculations.
5. Provide and implement a Storm Water Pollution Prevention Plan (SWPPP) for the construction period.

#### **4.1.3 Mechanical Design**

Prepare plant heat balances to reflect in-progress and final design for both 2x1 and 1x1 operation. Heat balances shall be provided for Minimum Load, Base Load, and Peak Load, with and without duct firing, operating at the following Ambient Conditions:

0°F, 20°F, 40°F, 52°F, 60°F, 80°F, 95°F, and 100°F

Heat balances shall include evaporative cooling / chillers at temperatures above 55°F. Contractor has the option to provide duct burning and power augmentation. If provided, heat balances should be provided reflecting these options.

Prepare plant flow diagrams to reflect proposed, in-progress, and final design.

Clearances shall be provided around equipment for ease of operation and maintenance in accordance with OSHA requirements and good engineering practices.

Prepare P&ID's showing equipment, equipment tag numbers, piping, pipe line numbers, valves, valve tag numbers, piping specials, system codes, connection numbers, heat tracing, equipment sizing/key performance, line sizes, valve sizes, material references, insulation references, instruments and controls, and conceptual control logic.

Prepare plant equipment arrangements and elevations dimensionally locating centerlines of all equipment included in the plant in all planes.

Prepare equipment installation detail drawings for all plant equipment.

Prepare piping plans, piping sections, and detailed isometric drawings showing above grade piping 2-1/2 inches in diameter and larger. Plans and sections shall include piping line tags, line sizes, and general dimensions as required to define the general location of the piping. Isometrics shall include dimensional information necessary to fabricate the piping and shall indicate pipe sizes, instrument connections, and attachments such as hangers. Isometrics shall include a detailed Bill of Material with material quantities and specifications for all materials required to fabricate the piping. Standard details shall be provided to show insulation supports and weld end preparation details. Piping 2 inches in diameter and smaller shall be shown schematically on appropriate drawings.

Design and provide schematics and plan drawings for all plant plumbing systems.

Design pipe hanger systems for piping 2-1/2 inches in diameter and larger and for pipe 2 inches and smaller that operates at greater than 250°F. The location for each hanger shall be shown on the piping drawings for space control and for coordination with other equipment and components. Provide detailed hanger design drawings indicating the

hanger installation requirements and including a detailed Bill of Materials with all component specifications indicated.

Provide design engineering and prepare drawings for plant facility HVAC systems.

Provide design engineering and prepare drawings for fire protection and control systems for plant facilities.

Design all piping and equipment insulation and lagging systems.

#### **4.1.4 Electrical Design**

Prepare a complete set of plant one-line diagrams of electrical systems rated at 480 volts and higher and a complete set of three-line diagrams for the generator voltage electrical system.

Prepare reports documenting electrical system studies performed for equipment selection, grounding design, cable sizing, and protective relay settings.

Prepare conduit, cable and raceway arrangement drawings for conduit, electrical cable trays, wire ways, and underground duct banks.

Prepare grounding drawings showing grounding method and connections to all equipment and building structures.

Prepare raceway and circuit lists for electrical and instrumentation installation and termination as required for construction only.

Prepare schematic / wiring / interconnection diagrams showing schematics and terminations for cables including all external connection terminal block numbers. Wiring drawings shall include connection drawings both internal and external, NEMA Standard across-the-line industrial control schematic drawings for all control systems provided or designed by Contractor, physical location drawings for all terminal blocks, power requirements, and other related items. Final electrical drawings shall include circuit numbers, wire designations, and similar features, marked on approval drawings by Engineer. Electrical drawings made for this Project shall have NEMA Standard symbols.

Provide power and instrument transformer connection and polarity diagrams.

Provide bushing and lightning arrestor outline drawings for switchgear and surge protection equipment.

Prepare lighting and communication system drawings.

Prepare power distribution drawings.

Prepare lightning protection and cathodic protection drawings.

#### **4.1.5 Instrumentation and Controls Design**

Contractor shall:

1. Provide design engineering for fully integrated microprocessor based Distributed Control Systems (DCS) to provide control, alarm, historical data archiving and performance monitoring functions for the major plant systems. Contractor shall design and specify all plant instrumentation, control, and monitoring devices.
2. Prepare contract instrumentation Lists.
3. Prepare SAMA and ISA style logic diagrams for all control algorithms executed within the DCS.
4. Prepare Instrument Installation Details.
5. Prepare location plans for all field devices including, but not limited to, control valves, transmitters, thermocouples, pressure and temperature gauges and flow elements.
6. Develop instrument data sheets for review and future use by Owner.
7. Design duct burner management systems including purge, burner control, and fuel safety systems.
8. Design CEMS systems as required by the project air quality permits and 40 CFR 60 and 40 CFR 75.
9. Design communications links for all FDIs (Foreign Device Interfaces) including, but not limited to, Fuel Gas Regulating Station Flow Computer, miscellaneous PLCs, and Remote Dispatching RTU.

#### **4.2 DESIGN REVIEWS**

Design Reviews shall be performed jointly by Contractor and Owner as part of the engineering execution of the work. PDS Model review will be the primary mechanism used for review of physical plant features. Design reviews will take place when engineering is about 20%, 50%, and 70% complete and appropriate HAZOP reviews will be completed as required.

#### **4.3 DRAWING AND SPECIFICATION REQUIREMENTS**

The type, preparation, approval, indexing, and distribution of drawings, specifications and data shall be governed by this Section. Drawings and specifications shall be sufficiently complete to ensure that the project will conform fully to the requirements of these Specifications and the Contract. All final drawings and specifications shall be provided on an indexed compact disk (CD). Drawings shall be prepared in Contractor's format. Final and as-built drawings, including OEM drawings, shall be submitted to Owner on CDs in AutoCAD 2002 (or current version) format or other Owner approved software. Three copies of the CDs of the drawings shall be provided. Contractor's specifications shall be prepared using Microsoft Word (current version) software and shall be submitted to Owner on CDs. Three copies of the CDs of Contractor's specifications shall be provided. Drawings shall reference and be compatible with all interfacing drawings. Drawings shall be modified to show the complete as-built facilities, including any modifications made to the facility during the warranty period resulting from defects corrected under the warranty.

#### **4.3.1 Drawing and Specification Schedule**

Contractor shall submit a Drawing and Specification Schedule to Owner for review as defined in Section 2 of the Contract.

The Drawing and Specification Schedule shall list all drawings and specifications to be produced by Contractor and shall include, but is not limited to, the following information:

1. Schedule date for the first issue for Owner's Review.
2. Schedule date for return of Owner's Review Comments.
3. Schedule date for issue for design, procurement or construction.
4. Actual date of issue.
5. Actual revision dates.
6. As Built Date as applicable.

Contractor shall revise and submit to Owner the Drawing and Specification Schedule monthly, including notation of approval dates, revisions, addition, and deletions.

#### **4.3.2 Drawing and Specification Submittals**

Contractor shall submit timely and descriptive information, which relates to the technical aspects of the Work. Such submittals shall be adequate to clearly define to Owner the system arrangement, operating modes, output performance, emission control, selection of construction materials and all other information as required by Owner to determine Contractor adherence to these Specifications.

Submittals shall be of the quality for legibility and reproduction purposes. Every line, character, and letter shall be clearly legible. All words and dimensional units shall be in the English language and in English units. Where standard documents are furnished which cover a number of variations of the general class of equipment, the document shall be annotated to clearly indicate exactly which parts of the drawing apply to the item for which the submittal is intended. If conforming submittals cannot be obtained, such documents shall be retraced, redrawn, or photographically restored as necessary to meet these requirements. Contractor's failure to satisfy the legibility requirements will not relieve Contractor from meeting the required schedule for submittal nor will it be cause for delay in the Project schedule.

Electronic submittals shall be in the form of AutoCAD and either Microsoft Word or Excel, or Adobe Acrobat files. Contractor shall identify each submittal by Project name and number, and indicate equipment or component tag number on each submittal drawings or document.

Owner will, by a notice to Contractor, classify the reviewed submittal to indicate the acceptance or rejection of the documents. Following are definitions of the action categories that will be used by Owner and their associated meaning and requirements of Contractor:



1. REVIEWED – NO COMMENT – Signifies that Equipment or Material represented by the Submittal conform with the design concept, comply with the intent of the Contract and Specifications, and are acceptable for incorporation in the Work. Contractor is to proceed with Work based upon the content of the Submittal. Final copies of the Submittal shall be transmitted to Owner as indicated below.
2. REVIEWED – NOTE COMMENTS – Signifies that Equipment or Material represented by the Submittal conform with the design concept, comply with the intent of the Contract and Specifications, and are acceptable for incorporation in the Work with Owner's comments indicated. Contractor is to proceed with Work based upon the content of the Submittal with all comments incorporated. Contractor shall submit a revised Submittal responsive to Owner's comments.
3. REJECTED – INADEQUATE INFORMATION – Signifies that Equipment or Material represented by the Submittal appear to conform to the design concept and appear to comply with the intent of the Contract and Specifications. However, the Submittal is lacking in adequate detail and information or contains discrepancies, which prevent Owner from completing his review. Contractor shall not proceed with Work until Owner approval is obtained. Contractor shall revise the submittal responsive to Owner's comments and resubmit for approval.
4. REJECTED – NOTE COMMENTS – Signifies that Equipment or Material represented by the Submittal do not conform with the design concept, do not comply with the intent of the Contract and Specifications, and are disapproved for incorporation in the Work. Contractor shall not proceed with Work until Owner approval is obtained. Contractor shall revise the submittal responsive to Owner's comments and resubmit for approval.
5. FOR REFERENCE, NO APPROVAL REQUIRED – Signifies the Submittals are for supplementary information only. Owner reviews such Submittals for general content, but not for substance.
6. FINAL – Signifies that Submittal has been previously approved and is being accepted as a final Submittal. Submittal is approved for incorporation by Contractor into the final project documents (O&M manuals, Technical Libraries, etc).

In resubmitting a Submittal which has been reviewed by Owner subject to compliance with comments, or which has been disapproved by Owner, Contractor shall state the action taken on each comment by indicating in his forwarding letter that the comment has been complied with, or by explaining why the requested alternative was not made, and Contractor is proceeding at his own risk.

Contractor shall resubmit submittals the number of times required to obtain the REVIEWED – NO COMMENT action on the submittal. Allow Owner the time indicated above in the Drawing and Specification Schedule section for each submittal and resubmittal. The requirement for any number of resubmittals will not be grounds for an extension in Key Dates provided Owner completes his reviews in the time frame specified.

Any resubmittal incorporating changes from the previous submittal shall have changes clearly marked or highlighted in both the hard copies and the electronic format. Any changes made to equipment or systems after receiving approval shall be indicated on the documents and the documents resubmitted for approval.

Contractor shall provide the quantities of submittals indicated in the following and in the format indicated or in a format approved by Owner in the Project Administration Manual per Section 4.3.5:

<b>DOCUMENT FORMAT &amp; QUANTITY</b>				
<b>Table 4.3-1</b>				
<b>TYPE</b>	<b>ABBREVIATION</b>	<b>PRINTS</b>	<b>FTP Server</b>	<b>TO</b>
Issue for Owner's Review	IOR	1	1	Owner
Issue for Information	IFI	1	1	Owner
Issue for Design	IFD	1	1	Owner
Revisions	REV	1	1	Owner
Issue for Bids	IFB	1	1	Owner
Issue for Purchase	IFP	1	1	Owner
Issue for Construction	IFC	1	1	Owner
As Built	AB	1	3 on CD	Owner

The documents to be submitted by Contractor shall include but are not limited to the following:

<b>Mechanical Submittals</b>	
<b>Table 4.3-2</b>	
<b>Submittal Description</b>	<b>Schedule</b>
Heat and mass balances for all guarantee points and minimum and maximum site conditions at Peak Load, Base Load and Minimum Load.	IOR, IFC, REV, IFD, AB
Plant fuel consumption at guarantee points and for Peak Load, Base Load, and Minimum Load.	IOR, IFC, REV, IFD, AB
Water balances for guarantee points and minimum and maximum site conditions	IOR, IFC, REV, IFD, AB
P & Ids	IOR, IFC, REV, IFD, AB
System Descriptions	IOR, IFC, REV, AB
Equipment arrangements and locations	IOR, IFC, REV, IFD, AB
Piping Plans & Sections	IOR, IFI, IFC, REV, AB
Piping Isometrics	IFI, IFC, REV, AB
Hanger Location Drawings	IFI, IFC, REV, AB
Hanger Detail Drawings	IFI, IFC, REV, AB
Steam blow and cycle flush piping	IOR, IFC, REV
Fire system drawings	IOR, IFC, REV, AB
Piping Line List	IOR, IFC, REV, AB
Equipment list	IOR, IFC, REV, AB
HVAC layout	IOR, IFC, REV, IFD, AB
Procurement specifications	IOR, IFB, IFP, REV
Construction specifications	IOR, IFC, REV
Startup, commissioning, and test procedures	IOR, IFC, REV
All vendor drawings and submittals (P&ID's, electrical one-lines and equipment outlines for review, all other drawings for information)	IOR, IFC, REV, IFI, AB
Operation and Maintenance Manuals	IOR, IFC, REV, AB
Pipe Stress Analysis	IFI, IFC, REV
All pump characteristic curves	IFI, IFC, REV, AB
List of all Special Tools for construction and maintenance	IFI, IFC, REV
Requirements for storage and protection of equipment	IFI, IFC, REV
Valve list	IFI, IFC, REV, AB
Lubrication list	IFI, IFC, REV, AB
Chemicals and Consumables list	IFI, IFC, REV, AB

<b>Civil Submittals</b>	
<b>Table 4.3-3</b>	
<b>Submittal Description</b>	<b>Schedule</b>
Site arrangement	IOR, IFC, REV, IFD, AB
Plant arrangement	IOR, IFC, REV, IFD, AB
Access roads, curbs, parking, walkways, and fencing	IOR, IFC, REV, IFD, AB
Grading Plans and Topography	IOR, IFC, REV, IFD, AB
Evaporation Pond Design and Plans	IOR, IFC, REV, IFD, AB
Construction Drainage Plan	IOR, IFC, REV
Final Drainage Plan	IOR, IFC, REV, AB
Yard piping	IOR, IFC, REV, AB
Underground electrical duct bank	IOR, IFC, REV, AB
Site construction utilities	IFI, IFC, REV
All Site surveys	IFI, IFC, REV
Laydown and temporary facility Plans	IOR, IFC, REV
All construction specifications	IOR, IFC, REV
Geotechnical Reports	IFI, IFC, REV

<b>Electrical Submittals</b>	
<b>Table 4.3-4</b>	
<b>Submittal Description</b>	<b>Schedule</b>
Electrical Plans and Elevations	IOR, IFC, REV, AB
Conduit, cable, and raceways	IOR, IFC, REV, AB
One-Line Diagrams	IOR, IFC, REV, IFD, AB
Three-Line Diagrams (generator and auxiliary voltages only)	IOR, IFC, REV, AB
All electrical Calculations including short circuit, load flow, relay coordination studies, etc.	IOR, REV
All Lighting and Communication Drawings	IOR, IFC, REV, AB
Plant Grounding System and Lightning Protection	IFI, IFC, REV, AB
Power and Control Wiring Diagrams	IOR, IFC, REV, AB
Electrical Schematics and Connections	IFI, IFC, REV, AB
Motor List	IFI, IFC, REV
All Motor Manufacturer's Data	IFI, IFC, REV
Switchboard Panel Layout	IOR, IFC, REV
Procurement Specifications	IFB, IFP, REV
Vendor Drawings (one-line and outline drawings as well as vendor manuals for review all other for information)	IOR, IFI, REV, IFC, AB

<b>Instrument and Controls Submittals</b>	
<b>Table 4.3-5</b>	
<b>Submittal Description</b>	<b>Schedule</b>
Instrument list	IFI, IFC, REV, AB
Control Valve and Relief Valve Lists	IFI, IFC, REV, AB
All Procurement Specifications including data sheets for all instruments, control valves, and relief valves	IFB, IFP, REV
Control System Architecture Diagram	IFB, IOR, IFC, REV, AB
DCS Control Loops	IOR, IFC, REV, AB
Control Logic Diagrams	IOR, IFC, REV, AB
Conceptual and Final Graphic Displays	IOR, IFC, REV, AB
Instrument Loop Diagrams	IFI, IFC, REV, AB
All Vendor Drawings and Data	IOR, IFC, REV
Instrument location plans	IOR, IFC, REV, AB
Instrument installation details	IOR, IFC, REV

<b>Structural Submittals</b>	
<b>Table 4.3-6</b>	
<b>Submittal Description</b>	<b>Schedule</b>
All Structural Steel Design Drawings	IOR, IFC, REV, AB
Foundation Location Plans and Foundation Drawings	IOR, IFC, REV, AB
All Structural Steel Fabrication Drawings	IFI, IFC, REV
All Rebar Drawings	IFI, IFC, REV
All Structural Calculations	IFI, IFC, REV
All Procurement Specifications	IFB, IFP, REV
All Construction Specifications	IOR, IFC, REV
Foundation Design Calculations	IFI, IFC, REV
All Structural Material Specifications	IFI, IFC, REV

<b>Architectural Submittals</b>	
<b>Table 4.3-7</b>	
<b>Submittal Description</b>	<b>Schedule</b>
Building Layout Drawings	IOR, IFC, REV, AB
Building Architectural Drawings	IOR, IFC, REV, AB
Building Interior and Exterior Finish Samples and Color Samples	IOR, IFC, REV
Building Technical Specifications	IOR, IFC, REV

<b>Miscellaneous Submittals</b>	
<b>Table 4.3-8</b>	
<b>Submittal Description</b>	<b>Schedule</b>
Plant Manuals	IOR, IFI, REV, AB
Manufacturers Instruction Books	IOR, IFI, REV
Start Up, Commissioning, and Test Procedures	IOR, IFI, REV
Critical Path Schedule	IOR, IFI, REV (monthly)
Project Status Reports	IOR, IFI (monthly)
Plant Administrative Manuals	IOR, IFI, REV

Distribution of drawings shall be to multiple parties as defined in the Project Administration Manual.

### **4.3.3 Plant Manual and Instruction Books**

#### **4.3.3.1 Plant Manual**

Manufacturers instruction books shall be integrated into a single plant manual with multiple volumes and provided on five (5) paper copy sets and five (5) CD copies in MS Word and/or PDF format

The plant manual shall contain site specific information on the plant operation. Normal operating sequences shall be described together with normal running inspections for all supplied equipment and systems. Cold, Warm, and Hot startup sequences and shutdown sequences shall be described in sufficient detail to identify all major steps, timeline for the steps, initiation of the step (i.e. operator, Mk VI, or DCS), permissive criteria for initiating the step, and mode of control for the step (i.e. Mk VI, DCS, manual). Troubleshooting and diagnostic recommendations shall also be included. Special notes and cautionary statements shall be included and highlighted throughout the manual to enable easy recognition of special procedures and techniques which must be followed to ensure correctness and safety for equipment and personnel.

Plant manual shall contain the latest as-built information for the facility. It is Contractor's responsibility to obtain all as-built information for all vendor's equipment. Manuals shall be updated with any modifications to equipment or systems made to the facility during the warranty period resulting from defects corrected under the warranty. Equipment, instrument, and parts lists shall be provided in Excel format (latest version).

#### **4.3.3.2 Manufacturer's Instruction Books**

Manufacturer's instruction books shall be provided for all electrical, mechanical, hydraulic, pneumatic and electronic equipment and instrumentation that requires explicit information and instruction for proper operation and maintenance. Instruction books shall be integrated into a plant manual as described above.

Commercial documents are acceptable to Owner, provided that the specific equipment used in the construction is clearly identified and that the following are included for all components and sub-components of a complex assembly:

1. Installation, start-up and initial test instructions
2. Manufacturing Test Reports.
3. Start-up Test Reports.
4. Operating instructions, including safety precautions.
5. Maintenance procedures and routine adjustments.
6. Parts illustrations, including parts lists adequate for the purpose of identifying and ordering replacement parts and lists of recommended spare parts for three (3) years of operation of any given component.
7. Wiring schematics for electrical equipment.
8. Hydraulic diagrams for hydraulic equipment.
9. Detailed descriptions of the functions of each principle component of a system.
10. Performance and nameplate data.
11. Alignment instructions if required.
12. Safety precautions.
13. Maintenance and major overhaul instructions, which shall include detailed assembly drawings with parts numbers, parts lists, instructions for ordering spare parts and complete preventative maintenance instructions required to ensure satisfactory performance and longevity of the equipment involved.
14. Lubrication instructions, which shall list points to be greased or oiled, shall recommend type, grade and temperature range of lubricants, and shall recommend frequency of lubrication.

#### **4.3.4 System Startup & Commissioning Test Procedures and Reports**

Startup and commissioning test procedures and reports shall be prepared by Contractor for all systems in accordance with the Contract. These procedures shall identify step-by-step actions to be taken to verify that systems operate in accordance with design intent and that all protection, control, indication and alarm functions are operational. Design criteria and acceptable levels (flow, pressure, temperature, time as appropriate) shall be identified in the procedure and provisions for recording of actual criteria observed during the startup will be included. Each step upon its completion shall require a signoff of both Contractor's Test Engineer and Owner's Representative. Five (5) hard copies and three (3) CD of the test procedures and of the test results shall be provided to Owner.

#### **4.3.5 Project Administration Manual**

Within 60 Days of notice to proceed, Contractor shall prepare and submit for approval a Project Administration Manual indicating: a responsibility matrix; key project contacts; document distribution matrix; project scope; project organization; execution plan; administrative procedures; quality control procedures; project schedule; equipment,

pipng, and instrument tagging procedures; design criteria; and other key project administration functions.

#### **4.3.6 Critical Path Schedule**

Contractor shall provide to Owner and update monthly a Critical Path Schedule per the Contract. Critical Path Schedule shall satisfy the requirements set forth in the Contract.

#### **4.3.7 Project Status Reports**

Contractor shall prepare and submit to Owner monthly Project Status Reports.

#### **4.3.8 Coordination Meetings**

Representatives of Contractor shall attend coordination meetings relative to the progress and execution of this Contract. At the initial meeting, Contractor shall present a plan including, but not limited to, the following: safety, project design parameters, constraints, assumptions, sequence and methods to be used in all phases of design; and detailed Project schedule showing major activities for each system for the entire Project.

Contractor and any other parties involved in the construction of the Project shall attend such pre-construction meetings as may be requested by Owner. At the initial meeting, Contractor shall present a construction plan including, but not limited to, the following: safety, procurement plan, major equipment receipt plan, construction sequence, methods and equipment to be used in all phases, tentative access and right-of-way roads, locations of staging areas, regrading of roads, moving of equipment/property that will interfere or impact construction and a construction schedule showing all activities for the entire construction phase of the Project.

Contractor shall be responsible for contacting all involved utility companies prior to starting any work to determine schedule of work and location of all temporary and permanent facilities in the Project area.

Contractor shall prepare an outage plan for all scheduled interruptions of electrical power or other utilities interference that would affect the Lake Side operating plant. This plan shall be submitted by Contractor to Owner for approval at least 30 days prior to outage. The plan shall include all reasonable efforts shall be taken to minimize impact on existing operations including sequencing of work to minimize outage time and work during off peak hours such as night and weekends.

Representatives of Contractor shall attend weekly coordination meetings to discuss matters relative to the progress and execution of the construction and startup of the Project. Current week progress and three-week look ahead schedules shall be presented by the Contractor and reviewed at these meetings in addition to other Site coordination items.

#### **4.3.9 Contractor Acquired Permits**

Contractor shall provide Owner three (3) copies of all Contractor Acquired Permit applications as they are being submitted to the responsible agency. Contractor shall provide Owner two (2) copies of all issued Contractor Acquired Permits upon approval from the responsible agency.



#### **4.4 QUALITY ASSURANCE**

1. Provide all equipment and products conforming to applicable Specifications, codes, standards, and requirements of regulatory agencies.
2. Design, fabricate, and assemble in accordance with the best engineering and shop practices.
3. Owner and Owner's representative shall have the right to inspect equipment and work at any time or place.
4. Contractor shall furnish all factory and field test procedures and reports to Owner for information.
5. At Owner's request, Contractor shall make available all manufacturers quality control documentation.
6. Contractor shall notify Owner of all Witness Tests at least two weeks in advance of such tests. Owner or Owner's representative may choose to witness test at no additional cost or schedule impact. Contractor shall provide list and schedule of Witness Tests to Owner for review.

## SECTION 5.0 MECHANICAL SCOPE

### 5.1 GENERAL REQUIREMENTS

This section provides requirements for major mechanical equipment, mechanical systems, and mechanical interfaces with other plant systems and off-site facilities.

#### 5.1.1 General

All mechanical equipment and systems shall be designed to continuously operate in a stable manner from Peak Load to Minimum Load. Mechanical equipment, systems, and piping shall be sized based on the operating performance parameters (pressure, temperature, flow rate, and the like) contained in Contractor's heat balances. Contractor shall evaluate the Project for the full range of operating loads including Peak Load, Base Load, and Minimum Load at the full range of design ambient conditions to determine the equipment and system sizing criteria. Contractor shall evaluate and define transient operating conditions (ie. startup, shut down and plant trip scenarios) in design of mechanical systems.

All equipment shall have sufficient design margins based upon good engineering practice. Following is a listing of the minimum design margins for select equipment and systems that shall be applied to the sizing criteria conditions (flow, head, duty, and the like):

<b>EQUIPMENT / SYSTEM</b>	<b>MINIMUM DESIGN MARGIN</b>
General Service Pump	10% flow, 5% head
Condensate Pumps	5% flow, 10% head
Boiler Feed Pumps	5% flow, 5% head
Circulating Water Pumps	2% flow, 5% head
Closed Loop Cooling Water Pumps	10% flow, 5% head
Closed Loop Heat Exchangers	15% Excess Heat Transfer Area
Fuel Gas Supply	5% flow at lowest anticipated heating value and pressure.

Line sizes and equipment capacities shall be determined based on flow rates and the specific performance criteria for each system. All sizing values (flow, horsepower, temperature, pressure, diameter, etc.) contained in these Technical Specifications and Conceptual Design Documents contained in Appendices B through E are preliminary. Contractor shall be responsible for final sizing and providing all mechanical equipment, systems, and piping to meet all requirements specified herein.

### **5.1.2 Piping**

Contractor shall size lines to provide fluid velocities that are in accordance with good engineering practice. Table 5-1 shows maximum pipeline velocity guidelines that shall not be exceeded without Owner's approval. The final selection and specification of piping materials shall be suitable for long term durability, shall satisfy all system design and code requirements, and in accordance with piping materials specified in Table 5-3.

### **5.1.3 General Arrangements**

The location of equipment and valves, and routing of pipe shall be based on safety, economics, ease of maintenance, and operation. Sufficient space shall be provided for maintenance of all equipment including equipment removal without excessive rigging or removal of surrounding equipment, piping, and valves. Where possible, locate valves to be safely accessible from walkways, accessways, or platforms.

### **5.1.4 Platforms**

Provide platforms to access equipment, instruments, engineered valves, start-up vent and drain valves, and other components requiring access for periodic maintenance, start-up, or operation. Provide stair access to maintenance areas that require bulky or heavy tools.

Review Gas Turbine-Generators, Steam Turbine Generator, HRSGs, and Cooling Tower layouts to provide additional access as required to comply with the Manufacturers requirements.

The following paragraphs define the general requirements of where platforming shall be provided. Design and construction requirements for platforms are defined in the Structural Scope section.

Provide platforms as required in the following to access elevated components not accessible from grade, unless specified otherwise:

1. Class 1 Areas – Regularly attended areas for daily or weekly lubrication, start-up, operation, inspection, observation or maintenance.
  - A. Provide platforms a minimum of 3 foot wide, clear of all obstructions with length as required (minimum 4 foot).
  - B. Provide stairs to access the platforms.
  - C. Provide emergency escape ladders for platforms as required by OSHA for platforms having dead ends.
2. Class 2 Areas – Maintenance areas requiring access monthly or annually for lubrication, repair, inspection, calibration or maintenance.
  - A. Platforms shall be adequately sized to allow two men to work simultaneously with tools and equipment internals (minimum of 20 square feet – 4 feet x 5 feet).

- B. Platforms shall be accessed by stair or ladder. Areas requiring maintenance with heavy or bulky tools (heavier than 25 lbs) shall be provided with stair access.

As a minimum, areas requiring access as defined above shall include, but not be limited to, the following:

1. Class 1 Areas
  - A. HRSG steam drums and associated level gauges, instrumentation, and safety valves
  - B. HRSG, STG, CTG and other equipment observation ports
  - C. Combustion turbine boroscope inspection ports
  - D. Internal and external platforms to provide access to all doors and maintenance access panels provide by CTG manufacturer, including the generator lead box.
  - E. CTG enclosure roof
  - F. Steam turbine operating deck
  - G. Steam turbine lube oil tank top
  - H. Ductburners (if required) and ammonia injection ports on HRSG casing
2. Class 2 Areas
  - A. Class 2 Areas: Calibrated Instruments including block valves necessary to isolate the instruments for safe routine maintenance and calibration.
  - B. Steam turbine bypass and desuperheating valves
  - C. Stack CEM ports and sample ports
  - D. CTG Inlet filter plenums
  - E. HRSG CEM ports and sample ports
  - F. Pressure indicators and gauges
  - G. Pressure safety valves
  - H. Sample Ports
  - I. Control valves
  - J. Elevated equipment manholes
  - K. Motor operated Isolation Valves
  - L. Air actuated isolation valves
  - M. Top manholes and gauging wells on large tanks
  - N. Relief valves and instrument on top of the ammonia storage tanks
  - O. Top of field erected tanks.

Provide a 3-foot minimum wide, continuous catwalk platform on the steam pipe rack. Platform shall extend between the HRSGs to provide access between the HRSG platforms and the steam turbine deck. Pipe Rack catwalk shall be accessible from each HRSG and the STG operating floor without descending to grade. Provide stairs at changes in elevation for Pipe Rack catwalk.

Provide stairway from top of pipe racks to each drum level and two stairways from top of Pipe Rack or Pipe Bridge to ground level. Plant layout shall be in general conformance with General Arrangement Drawings in Appendix C.

Minimize platforms and stairways over 25 feet above grade.

### **5.1.5 Accessways and Clearances**

Maintenance and equipment access areas and equipment laydown areas are designated on the Conceptual Design Drawings shown in Appendix C. Contractor shall finalize the maintenance laydown areas, show them on general arrangement drawings, and obtain Owner's approval of the general arrangements prior to detailed design.

Contractor shall provide an area to pull the generator rotor on the steam turbine operating level. The pull area shall have a strong back and shall be a platform capable of supporting the generator rotor.

**Table 5-1  
Maximum Pipeline Velocities\* - Feet/Second**

Nominal Diameter (Inches)	Super-heated Steam	Saturated Steam > 25 psig	Saturated Steam <25 psig	Compress Air/Gases	Boiler Feed Suction	Boiler Feed Discharge	Condensate Pump Discharge	Circulating Water Pump Discharge		
1	110	100	65	30	3	8	-	-		
1-1/2	130	110	70	35	3	8	-	-		
2	150	120	75	40	4	8	8	-		
4	200	140	85	50	4	12	8	-		
6	230	150	95	60	4	14	8	-		
8	250	160	100	60	4	17	10	-		
10	250	160	100	60	4	18	10	-		
12	250	160	100	60	4	20	10	6		
16	250	160	100	60	4	25	10	6		
20	250	160	100	60	4	25	10	6		
24	250	160	100	60	4	25	10	8		
30	250	160	100	60	4	25	10	10		
36 & Larger	250	160	100	60	4	25	10	10		

\*Actual pipeline velocities shall be less than those specified and shall be selected by Contractor based on the system design conditions and sound engineering practice.

5.1.5.1 Horizontal Clearances (Minimum):

Horizontal clearances (clear of all piping and accessories) shall be maintained as follows (unless approved otherwise by Owner):

- |   |             |
|---|-------------|
| 1. Crane Accessways:                      | 25'-0"      |
| 2. Fork Truck / Pick-up Truck Accessways: | 15'-0"      |
| 3. Operating Aisles:                      | 4'-0"       |
| 4. Elevated Maintenance Platforms:        | 3'-0"       |
| 5. All Around Pumps & Blowers:            | 3'-0"       |
| 6. All Around Boiler Feed Pumps:          | 5'-0"       |
| 7. All Around Heat Exchangers:            | 3'-0"       |
| 8. Heat Exchangers Pull Space:            | As Required |
| 9. All Around Tanks:                      | 5'-0"       |
| 10. Around Other Major Equipment:         | 5'-0"       |
| 11. One Side of Control Valve Stations:   | 3'-0"       |
| 12. Back Side of Control Valve Stations:  | 1'-6"       |

Provide fork truck / pick-up truck aisles on access side of all equipment with motors, large manholes, or endplates and next to all equipment requiring chemical addition or replacement of totes.

5.1.5.2 Vertical Clearances (Minimum):

- |   |  |
|---|--|
| 1. Overhead clearances (clear of all piping and accessories) shall be maintained as follows (unless approved otherwise by Owner): |  |
| 2. In buildings:  | 7 feet – 0 inches  |
| 3. Normal operating or maintenance access areas:  | 8 feet – 0 inches  |
| 4. Elevated platforms and stairways:  | 7 feet – 0 inches  |
| 5. Control Valves:  | As required to remove actuator and pilot (12 inch minimum) |
| 6. Plant access & maintenance roads & crane accessways:   | 17 feet – 0 inches   |

**5.2 MECHANICAL SYSTEMS AND EQUIPMENT**

**5.2.1 General**

Provisions shall be included in the design of all mechanical systems to allow the performance of all routine maintenance without requiring a plant shut down. Provisions shall include but not be limited to redundant equipment, isolation valves, and access spaces.

Contractor shall:

1. Receive, inspect, store, unload, erect, clean, lubricate, align, and prepare all equipment for operation in accordance with equipment manufacturer's instructions.
2. Provide lifting lugs on all equipment components or system components requiring removal for maintenance and weighing over 25 lbs.
3. Provide OSHA approved guards on all rotating components.
4. Select materials of construction and design equipment and systems to provide a minimum of a 30-year operating life at all operating conditions specified.
5. Provide major system components designed for a 30-year life without the need for major repairs or replacement. Only routine maintenance items (i.e. belts, couplings, bearings, seals, and the like) shall require replacement at increased frequencies.
6. Provide grounding lugs and ground all equipment and structural components.
7. Care shall be taken to assured that piping connections are made to equipment and machinery so that no reactions or moments in excess of those allowed by the manufacturer are imposed during installation, test, or operation.
8. Provide access doors on equipment and systems as required to adequately clean, inspect, and maintain all system components. In general, access doors shall be bolted and sealed. Access doors over 25 lbs shall be hinged or supplied with a davit.
9. Extend all grease or lubrication lines for equipment or instruments to be accessible from grade or operating platforms.
10. Provide actuators on all start-up drain and vent valves on the steam turbine, HRSG, steam piping, and boiler feed pump, and elsewhere to enable remote start-up and shutdown of the units.

### **5.2.2 Pumps - General**

General Service Pumps shall be designed and fabricated in accordance with the recommendations of the Hydraulic Institute and be suitable for the service. All end suction pumps shall be in accordance with ANSI standards.

Horizontal pumps shall have motor and pump mounted on a common baseplate and connected with a flexible spacer coupling and non-sparking coupling guard. Baseplate shall include a containment rim to contain 115% of the maximum amount of lubricant contained in the pump. Provide a drain valve and plug on the baseplate.

All pumps shall be supplied with mechanical seals designed for the service. Similar parts of duplicate pumps shall be completely interchangeable. Equipment and piping arrangement, and nozzle orientation, shall be selected for ease of maintenance and to



minimize the dismantling or removal of piping and electrical connections for maintenance.

The supplied impeller on all pumps, except the boiler feedwater pumps, shall be a minimum of ½ inch smaller than the maximum impeller for the pump casing.

Pump head curves shall rise continuously from design head to shut-off head. Shut-off head for Boiler Feed Pumps shall be a minimum of 115% of the rated head at the design condition and a maximum of 130% of the rated head at design conditions. Shut-off head of all other pumps shall be a minimum of 115% of the rated head at the design conditions and a maximum of 150% of the rated head at design condition. For condensate and boiler feed pumps maximum shut-off head shall be 140% of rated head at design condition.

Pumps shall operate at the left of the best efficiency point at design conditions.

Motors shall be sized for end of curve conditions for supplied impeller. Motor service factor may be used in determining motor size for end of curve conditions. Motor service factor shall not be used in selecting motor for operating or rated conditions.

### **5.2.3 Tanks and Vessels - General**

One (1) new Raw Water Storage Tank and one (1) new Demineralized Water Storage Tank shall be added for Block 2. These tanks shall be sized as required by Contractor's design. The new Raw Water Storage Tank shall not include capacity for Fire Protection Water for Block 2. The existing Block 1 tank shall be common to both Block 1 and Block 2 for fire protection water supply.

Field erected tanks shall be designed, fabricated, inspected, examined, and tested in accordance with the applicable API, NFPA or AWWA Standards.

Demineralized Water Storage Tank shall be stainless steel. Both the Raw Water Storage Tank and Demineralized Water Storage Tank shall be insulated.

All roof seams shall be fully seal welded. Roof seams on the demineralized water tank shall be butt joints. Interior welds on all tanks that are internally coated shall have interior welds ground smooth. Interior and exterior shall be protected with a suitable lining or coating material.

Tanks and vessels with a design pressure over 15 psig shall be designed, fabricated, inspected, examined, tested and stamped in accordance with ASME Section VIII, Division I.

Carbon Steel water storage tanks shall be lined or coated on the inside for corrosion protection. Lining and coatings selected shall be suitable for the intended service. Linings and coatings shall be applied in accordance with coating manufacturer's recommendations.

Tank and vessel construction materials shall be selected for the intended service to minimize corrosion and provide an extended life as defined for the plant. A minimum corrosion allowance of 1/16 inch on all carbon steel tanks and vessels shall be provided.

Contractor shall:

1. Provide cathodic protection for all tanks and vessels as recommended by a corrosion engineer after reviewing soils conditions for the site. Obtain Owner's approval of cathodic protection design prior to executing work. Block 2 Cathodic Protection System shall be compatible with the existing plant cathodic protection system.
2. Provide a minimum of two manways on each field-erected tank. Manways shall have a minimum opening size of 30 inches diameter. One manway shall be located on the side of the tank or vessel and shall be accessible from grade. The other shall be accessible from the top of the tank or vessel. Provide a stairway to access the top of each tank in excess of 25 feet tall. Where the roof angle at the manway exceeds 20 degrees from the horizontal, Contractor shall provide a suitable platform.
3. Provide one manway with a 24-inch minimum opening for shop-fabricated tanks or vessels that are over 36 inches in diameter. Smaller vessels shall be provided with two 6-inch diameter hand holes. Provide a ladder to access the top of all tanks below 25 feet high.

Tank level gages shall be clearly visible from the tank loading area.

#### **5.2.4 Heat Exchangers - General**

Shell and tube heat exchangers shall be designed, fabricated, inspected, examined, tested and stamped in accordance with ASME Section VIII, Division I, and TEMA, Class C. Shell and tube heat exchangers shall be supplied with flanged channels and flanged channel covers to facilitate access to both the shell and the tube sides for maintenance and cleaning. Provide valved shell and tubeside vents and drains on each exchanger. Provide double-groove, rolled tubes on all heat exchangers.

Plate and frame heat exchangers shall be designed, fabricated, inspected, examined, tested and stamped in accordance with ASME Section VIII. Plate exchangers shall be of the removable plate design and shall be provided with a frame and rollers to support the backplate during plate removal. Frames shall be sized to allow the addition of a minimum of 50% more plates.

Carbon steel components on heat exchangers shall be supplied with a 1/16-inch minimum corrosion allowance.

#### **5.2.5 Combustion Turbine Generator (CTG) System**

General: Contractor shall provide two (2) GE 7FA/2.6DLN or two (2) Siemens-Westinghouse W501FD2/3 combustion turbines for combined cycle operation including all materials, services, and required labor necessary for a complete functional installation including all requirements for startup and testing. Gas turbines must meet all latest TIL/Service Bulletins relating to product reliability, design or manufacturing defects as implement on currently manufactured or shipped by the OEM. Equivalent starts penalty factor for trips from load (75% or greater) shall be eight (8) or less.

The equipment shall be designed and manufactured for the application at the specified conditions without overstressing any components. The unit shall be designed to automatically maintain itself in a standby condition ready for immediate operation at all times. Contractor shall provide all necessary connections for measuring pressure drop across filters, compressor pressure ratio, turbine exhaust pressure and temperature, inlet air temperature, inlet pressure drop and turbine firing temperature. All control signals shall have a range of 4-20 mA unless specified otherwise.

**Performance Guarantees:** All ratings and guarantees shall be made without tolerances. New condition shall be considered to be the condition of the machine immediately after installation and less than 200 actual fired hours.

**Capacity of Unit:** The gas turbine-generator unit base net output capacity at the ambient conditions specified after unit auxiliary power is deducted from gross output. The capacity, defined as "base rating" shall be that load obtained at the specified ambient conditions and operated at a Turbine Inlet Temperature level consistent with maximum achievement of anticipated parts life. Provide performance correction curves with the Proposal which plot the effect back pressure, barometric pressure steam or water injection, gas turbine inlet air temperature, inlet air pressure drop, and relative humidity on turbine-generator output, air flow, heat rate, and exhaust temperature. These correction curves will be used for performance testing correction to guarantee conditions.

**Fuel:** Gas turbine-generator units shall be designed to operate satisfactorily at all loads when firing natural gas. See Appendix J for Fuel Gas analysis information.

**Combustion System:** GTGs shall be provided with dry low NO<sub>x</sub> burners. System shall include thermal barrier coated liners, transition pieces, flame detectors, and a dynamic combustion monitoring system.

**Sound Criteria:** Contractor shall guarantee noise limits per Section 1.

**Exhaust Emissions:** Contractor shall submit with the Proposal a statement of guarantee that the gas turbine unit and auxiliaries are designed and constructed to operate in compliance with the aforementioned standards.

**Evaporative Air Cooler:** Shall be 85% effective and designed to work in conjunction with an inlet air filtration system. A conductivity Control System shall be provided.

**Control of Unit:** Each CTG shall be supplied with a dedicated turbine control system. The turbine control system contains the unit metering, protection, and control logic required for safe and reliable turbine operation. Standard control of each gas turbine generator, as provided by the manufacturer, shall be from each respective supplied local station and from a common remote station. Remote operator station shall have identical hardware and software as the local operator station and shall also be equipped with multiunit capability to allow for the control and operation of each turbine. In addition, to being designed for starting from the local station located in a control enclosure adjacent to each unit, and remotely from a common remote control station, the unit shall be designed for starting remotely through the DCS. A command to "start" the unit from

either the local or remote control station or the DCS shall initiate the automatic start-up sequence to start unit, bring the unit up to speed, synchronize, and pick up a preset minimum load. Controls shall be designed to integrate the starting and stopping of any fuel gas compressor into the automatic start-up and shutdown sequence, if a compressor is required. Controls shall be designed so unit can be loaded from the local or remote station, or DCS. When unit is on-the-line, the following functions may be performed from the local or remote station, or DCS:

1. Manual load (governor) control
2. Manual voltage (excitation) control
3. Manual stopping of unit

Operation of the manual "stop" switch on the local or remote station or remote DCS shall initiate the automatic shutdown sequence to safely shutdown the unit. The unit shall be automatically shut down in a safe manner in the event of abnormal, injurious, or faulted condition in any part of the gas turbine-generator unit, or its associated mechanical and electrical auxiliary equipment, either during start-up or during "on-line" operation. Unit shall be designed for complete remote and automatic operation. Each condition preventing operation or causing shutdown of unit shall be specifically identified by an alarm on the local, remote control station and DCS. Shutdown sequence shall be complete, including reset ready for automatic restarting. The turbine control system shall include provisions for HRSG interlocks. Provide variable inlet guide vanes on compressor inlet. Guide vanes shall be automatically controlled. Provide vane position indication at both local and remote control stations. Additional turbine control description is provided in SECTION 5.2.5.19. Additional interface description to the DCS is provided in SECTION 9.

Start-Up of Unit: Starting sequence for the unit shall be interlocked to prevent operation when conditions are not normal in all parts of the unit for satisfactory and safe operation. Upon actuation of the unit, start control from the control board or remotely:

1. Gas turbine auxiliaries are automatically energized in correct sequence.
2. If there are no malfunctions of the auxiliaries, the turbine is brought up to speed; otherwise the equipment is automatically shutdown, and an alarm is transmitted to both local control and the DCS.
3. Automatic governor and excitation control establishes the generated voltage at correct potential and frequency for synchronizing.
4. The equipment furnished shall assure that the generator voltage matches the bus voltage within limits safe to the equipment, with the bus voltage level within  $\pm 5\%$  of set point.
5. Generator breaker shall close automatically under control of automatic synchronizing equipment.
6. Provide selection locally at unit for synchronizing automatically or manually by synchroscope.
7. Upon automatic closure of the generator breaker, the unit shall load to a preset value.

### 5.2.5.1 Gas Turbine and Accessories

Summary: Gas Turbine-Generator unit shall be a gas turbine mechanically coupled to the electrical generator. Gas turbine-generator unit shall be a factory-assembled "package type" designed for automatic operation and shall be manufacturer's standard design as far as is consistent with the intent of these specifications.

Applicable Codes and Standards: Design, fabricate, assemble, install, and test equipment so that when operated in accordance with manufacturer's recommended procedures, it will conform to the applicable provisions of, but not limited to, the following standards:

1. National Electrical Manufacturers Association (NEMA):
  - A. SM33 - Gas Turbine Sound
2. American Society for Mechanical Engineers (ASME):
  - A. Boiler and Pressure Vessel Code for Unfired Pressure Vessels
  - B. B31.1 - Code for Pressure Piping
3. American Society for Testing and Materials (ASTM):
  - A. A53 - Welded and Seamless Steel Pipe
  - B. A312 - Seamless and Welded Austenitic Stainless Steel Pipe
4. Society for Protective Coatings (SSPC) Surface Preparation Specifications:
  - A. SP-10 - Near-White Blast Cleaning: At least 95% of every 9 square inches shall be free of visible residues
  - B. SP-11 - Power Tool Cleaning to Bare Metal

#### Factory Tests:

All standard factory tests on equipment and all tests required by the applicable codes shall be made including:

1. Rotor overspeed test at not less than 110% speed.
2. Vibration and mechanical balance of assembled rotating parts.
3. Lubricating system tests including hot oil flushing and bearing inspection.
4. Comprehensive tests of all systems and controls to assure proper assembly and connection, including simulation tests of all safety devices.
5. Hot oil flushing of all hydraulic and liquid fuel piping.

Notify Owner when factory tests are to be made so that they may have a representative witness the tests, if desired.

Submit certificate of completion of all other tests in triplicate.

#### 5.2.5.2 Prime Mover

The prime mover shall consist of a gas turbine provided with all standard and special accessories as specified and as required for this application.

Gas turbines shall be designed to allow continuous operation.

Compressor inlet equipment shall include air ducting with inlet filters, expansion joints, and transition sections as required, complete with airtight hinged access doors. Modulating Inlet Guide Vanes (IGV) shall be included to control air-flows during start-up for protection against compressor surge and for improved part load performance during combined cycle operation.

The gas turbine ignition system shall be automatic. The ignition system shall provide for 100% backup, and the unit shall be capable of successful starts with 1/2 of the ignition system out of operation.

Gas turbine compressed air system shall be provided as required for blade cooling, seals, complete with instrumentation and alarms.

Main reduction gear shall be designed to conform to AGMA standards for service and application.

Frame-type industrial gas turbines shall be provided with a turning gear to prevent adverse deflections of the shaft during the cooling-off period following shutdown.

Provide cooling air if required to maintain proper turbine temperatures.

#### 5.2.5.3 Governing System

Provide speed governing system including:

1. Speed governor on output shaft or shafts.
2. Fuel control mechanism.
3. Speed changer with provisions for remote adjustment.
4. Minimum fuel limiter.

Provide adjustable load limiter.

Provide fuel control systems, including control valves.

Provide temperature control system, including the following:

1. Temperature detectors.
2. Load limiting controls based on exhaust temperature.
3. Load limiting selector switch for selection of base or peak mode of operation.

Provide overspeed and over-temperature system, including the following:

1. Overspeed governor on turbine shaft.
2. Over-temperature detection.
3. Necessary protection equipment.
4. Fuel stop valves.

#### 5.2.5.4 Fuel System

Provide fuel system complete and ready for operation, including the following:

1. All necessary control, trip, and stop valves.
2. Stainless steel gas piping.
3. Fuel strainers and dual filters with provisions to change filters under load.  
Provide differential pressure gauges for all strainers and filters.
4. Gas flowmeters with  $\pm 1\%$  system accuracy for the design fuel to measure net fuel consumed. Orifice type flow measurement system. Supply meters complete with totalizer and other accessories as required to be incorporated into the manufacturer's normal unit control systems. Meter shall supply compensated electrical output proportional to flow.
5. Flowmeters shall meet accuracy requirements of CEMS / permit as a minimum
6. Pressure switches, pressure gauges, and thermometers.
7. Electric heaters, insulation, and lagging as required.

#### 5.2.5.5 Water/Steam Injection System

Provide water or steam injection system complete and ready for operation for power augmentation, including the following:

1. All necessary control, trip, stop, and check valves
2. Water inlet strainer with five-micron filter elements. Two 100% capacity strainers with on-line manual switching shall be provided. Differential gauges and transmitters shall be included.
3. Water injection pumps, motor driven. Provide two 100% pumps where 100% is defined as the flow for NOx control or power augmentation flow whichever is greater. This will allow for one spare pump to be available when the gas turbine is operating in power augmentation mode.
4. Water injection manifolds and nozzles as required
5. Flowmeters to measure net water consumption for both emission control and power augmentation
6. Pressure gauges, pressure switches, thermometers
7. Water flow control and water injection system monitoring devices provided with data acquisition and storage
8. Relief valves
9. Recirculation valves and/or orifices, if required
10. Unit heaters and ventilation equipment, as required
11. Electrical heaters, heat tracing, insulation, and lagging as required
12. Turbine control system shall command injection water supply pumps which feed water to the turbine injection skid to start at the proper time in the engine starting sequence

Provide water or steam injection system with all required equipment, controls, wiring, piping, and valves to automatically supply injection water to the gas turbine at the proper pressure and in the required quantities.

#### 5.2.5.6 Lubricating Oil System

Provide oil reservoirs and dual, full flow filters with replaceable-type cartridges.

Provide dual plate and frame type lube oil coolers with stainless steel plates.

Lube oil coolers and filters shall have ASME code stamp.

Provide all valves and controls necessary to regulate cooling water flow to maintain proper lube oil temperatures. Cooling water from the plant system will be used.

Provide complete lubricating oil system including the following:

1. AC Motor driven lube oil pumps
2. AC motor driven auxiliary standby lube oil pump
3. DC emergency bearing oil pump for safe shutdown of unit in the event of an AC power failure
4. Oil reservoir heaters with thermostatic controllers designed for -20°F
5. Oil piping, valves, instruments, and controls including connections to reservoir and cooling system. Lube oil supply piping shall be 304L stainless steel. Lube oil drain piping shall be carbon steel. Lube oil system valves shall have stainless steel trim.
6. Lube vent demister for mist elimination
7. Dial-type thermometers to indicate oil supply and return temperatures
8. Valves, controls, and indicating instruments as required

#### 5.2.5.7 Starting System

Provide complete starting system capable of starting the unit over the range of ambient conditions specified.

Starting system shall be of the electric motor or use of generator as a motor to start unit is also acceptable.

Electric motor starting system shall include the following:

1. Electric starting motor sized to start the unit without exceeding nameplate horsepower rating.
2. Torque converter, couplings, and clutch.
3. All required controls.
4. Cooling system.

If generator is used as motor to start unit, provide all transformers, controls and interlocks necessary to provide for safe start-up of turbine.



#### 5.2.5.8 Special Tools

Provide one set of any special lifting slings or fixtures required for routine inspections, hot gas path inspections, and major overhauls.

Provide one set of all special wrenches and tools required for maintenance.

#### 5.2.5.9 Inlet Air Filter

Provide self cleaning inlet air filtration system, complete with filter housing and all required ductwork to install inlet air filter.

Arrangement shall be up and forward inlet system arrangement. Face velocity at inlets shall not exceed 600 fpm.

Provide severe duty filter media (high humidity / corrosive environments).

Housing and ductwork shall be steel with hinged access doors. Provide caged ladder access to inlet filter compartment, electric hoist with 500 lb lift capacity, and inlet filter compartment interior lighting.

Provide dust collection kit under each module.

Provide Air Processing Unit (APU) for filter cleaning. Include APU heat tracing kit.

Provide inlet system differential pressure indicator and transducer to measure pressure drop across filtration system and provide an alarm to indicate dirty filters and initiate the self cleaning cycle.

Provide frost point detector with icing alarm.

Provide steel inlet louver complete with stainless steel bird screen over inlet and stainless steel inlet silencing perforated sheet.

Inlet ducting shall include inlet silencing, expansion joint, 90 degree elbow, transition piece, compressor inlet humidity sensor, and compressor inlet temperature thermocouple.

#### 5.2.5.10 Exhaust Connection

Gas turbine shall be provided with an axial exhaust connection.

Provide expansion joint to minimize loads on turbine from ductwork expansion. Expansion joint shall be designed for axial, lateral, or angular displacements. Expansion joint material shall be suitable for use with gas turbine exhaust temperature.

Exhaust system shall be carbon steel shell and stiffeners with stainless steel internal lagging.

#### 5.2.5.11 Bypass Stack

No bypass stack shall be provided.

#### 5.2.5.12 Water Wash System

Provide water and/or solvent wash system complete with all piping, valves, pumps, motors, tanks, including freeze protection, and controls.

System shall be skid mounted and enclosed.

System shall allow washing of compressor while turbine is either on- or off-line.

Each wash skid shall service two gas turbines.

#### 5.2.5.13 Insulation

Furnish and install all required thermal insulation including insulation for compressor, combustion chambers, turbine casing, exhaust ducts and hoods, piping, oil tanks, and as required for personnel safety. Include lagging if insulation is exposed.

Thermal insulation shall be designed so that outside surface temperature of lagging will not exceed ambient air temperature by more than 10°C when gas turbine is operating.

All insulation materials shall be asbestos-free.

#### 5.2.5.14 Sound Control Equipment

Silencers and sound control equipment shall be designed and applied as required to attenuate all noise generating sources in the gas turbine generator unit, compressor inlet equipment, gas turbine exhaust equipment, and all auxiliaries as required to meet the guaranteed silencing criteria.

Silencers shall be durable construction with sound-absorbing media encased behind perforated panels of type of metal required for a service life equal to the normal design life of the facility.

#### 5.2.5.15 Maintenance Access

Submittals shall include adequate data to determine size of crane required and access space required for crane.

Enclosure shall include provisions for the removal of components of the engine for maintenance with welding. Provisions at roof joints shall be made to prevent the entry of wind driven rain.

#### 5.2.5.16 Fire Protection System

Provide fire detection system and fire protection system for turbine and accessory compartments and enclosures, including low pressure carbon dioxide supply system. Provide compartment warning signs and compartment exterior alarms.

Provide fire detectors to trip the unit, actuate the fire protection system, stop ventilating fans, close ventilating louvers, and alert the operator.

System shall be of the prolonged-discharge type designed to provide proper concentrations in each protected area. Storage system shall be sized for two discharges.

Perform an acceptance test of system to verify proper operation and concentration during commissioning. Recharge all cylinders or tanks after test.

Provide hazardous atmosphere detectors and readouts for ammonia and hydrogen.

#### 5.2.5.17 Vibration Monitoring Equipment

BFP shall be equipped with Bentley Nevada Vibration Monitoring Control monitoring systems. This system shall be tie to Block 1 main Bentley Nevada Vibration Monitoring System. Display data on both local and remote control station and the DCS.

#### 5.2.5.18 Painting

Turbine-generator and appurtenances shall be surface cleaned to SSPC-SP10 with profile depth of 1.5 mils, and factory prime painted with one coat of inorganic zinc primer to a dry film thickness of 2.5 mils.

Turbine-generator and appurtenances shall be field painted with one coat of polyamide epoxy as follows:

1. Thoroughly clean all surfaces to be painted. Prepare uncoated and damaged coating areas to SSPC-11 quality.
2. Apply one coat of the same primer applied in the factory on all areas where shop coat has been damaged or areas which are uncoated.
3. Apply one finish coat with a minimum dry film thickness of 5.0 mils.

Colors will be selected from manufacturer's standard colors by Owner.

#### 5.2.5.19 Gas Turbine – Electrical and Controls

General: Electrical equipment and controls shall be manufacturer's standard pre-engineered package and shall include all special and optional accessories required for the application.

Logic apparatus for automatic control of starting, operation, and shutdown of the gas turbine unit and gas compressors shall be microprocessor based system with communication links for interconnection with other gas turbine control systems and plant DCS.

Electrical equipment and controls shall include all equipment required for operation of appurtenances furnished, other specified devices, and all safety equipment required for automatic shutdown of the plant in event of malfunction.

Factory fabricate and completely assemble and wire circuit breakers and switchgear at Contractor's manufacturing location. No welding shall be required to complete field assembly of these items. Pre-engineered enclosure shall include redundant air-conditioning.

Electrical equipment shall include the following:

1. Auxiliary switchgear, motor control centers and power panels as required.

2. 125Vdc power panel for dc controls, emergency motor power, and dc motor controls.
3. 125Vdc battery of capacity required for unit.
4. Local turbine and generator control boards.
5. Excitation equipment and controls.
6. Motors as required to run necessary auxiliary equipment.
7. Provision for remote control capability.
8. Complete logic control system for starting, synchronizing, shutdown, and protection of the unit (including gas compressors).
9. Protective relays for generator.
10. Generator surge protection equipment.
11. Redundant battery chargers.
12. Static or rotary inverter equipment, if required, for ac control power for emergency shutdown conditions.
13. Other equipment as required for application.
14. A manual transfer arrangement for the 480V power supply interlocked to prevent paralleling the unit supply and the standby supply.

References:

Institute of Electrical and Electronics Engineers (IEEE):

1. No. 21 - Outdoor Apparatus Bushings, General Requirements and Test Procedures.
2. No. 32 - Neutral Grounding Devices.
3. No. 24 - Electrical, Dimensional and Related Requirements for Outdoor Apparatus Bushings.

American National Standards Institute (ANSI):

1. C37.04 - Rating Structure for ac High-Voltage Circuit Breakers Rated on a Symmetrical Current Basis.
2. C37.06a - Schedules of Preferred Ratings and Related Required Capabilities for ac High Voltage Circuit Breakers Rated on a Symmetrical Current Basis.
3. C37.09 - Test Code for Power Circuit Breakers Rated on a Symmetrical Current Basis.
4. C37.11 - Power Circuit Breaker Control.
5. C37.13 - Low-Voltage ac Power Circuit Breakers Used in Enclosures.
6. C37.16 - Preferred Ratings Related Requirements and Application Recommendations for Low-Voltage Power Circuit Breakers and ac Power Circuit Protectors.
7. C37.17 - Trip Devices for ac and General-Purpose dc Low-Voltage Power Circuit Breakers.
8. C37.20 - Switchgear Assemblies Including Metal-Enclosed Bus.
9. C37.90 - Relays and Relay Systems Associated with Electric Power Apparatus.
10. C37.100 - Definitions for Power Switchgear.
11. C57.12.00 - General Requirements for Liquid Immersed Distribution, Power, and Regulating Transformers.
12. C57.12.10 - Requirements for Transformers 230,000V and below 833/958 through 8,333 / 10,417 kVA, single phase, and 750 / 862 through 60,000 / 80,000 / 100,000 kVA three phase.

13. C57.12.70 - Terminal Markings and Connections for Distribution and Power Transformers.
14. C57.12.80 - Terminology for Power and Distribution Transformers.
15. C57.12.90a - Test Code for Liquid-Immersed Distribution, Power and Regulating Transformers.
16. C57.13 - Requirements for Instrument Transformers.
17. C76.1 - General Requirements and Test Procedure for Outdoor Apparatus Bushings.
18. C76.2 - Electrical, Dimensional and Related Requirements for Outdoor Apparatus Bushings.

National Electrical Manufacturers Association (NEMA):

1. SG1 - Electric Power Connectors.
2. SG4 - Standards for Power Circuit Breakers.
3. SG5 - Electric Switchboards.
4. LA1 - Lightning Arrestors.
5. TR1 - Standards for Transformers, Regulators, and Reactors.
6. E1-2 - Instrument Transformers.

Applicable rules of the National Electrical Code and National Electric Safety Code.

Factory Tests:

All standard factory tests on equipment and all tests required by the applicable codes shall be made including:

1. Standard ANSI dielectric tests.
2. Standard circuit breaker tests.
3. Comprehensive tests of all systems and controls to assure proper assembly and connection, including simulation tests of all safety devices.

Notify Owner and Engineer when factory tests are to be made so that they may have a representative witness the tests, if desired.

Submit certificate of completion of all tests in triplicate.

#### PRODUCTS:

GENERAL: Design, fabricate, assemble, install, and test equipment in accordance with applicable standards specified above.

#### GENERATOR CONNECTION EQUIPMENT:

Provide generator surge protection equipment housed in a metal-enclosed dead-front enclosure, containing station-type lightning arresters and surge capacitors of proper rating to adequately protect the electrical apparatus. Surge protective equipment shall be physically arranged so as to be connected as close as possible to the generator terminals.

Provide generator neutral grounding distribution transformer and secondary resistor housed in a ventilated metal enclosure. Transformer and resistor shall be adequately sized for the generator based upon a one-minute rating.

RELAYING:

Provide all protective relays for the generator and auxiliaries as required for safe start-up, operation, and shutdown of the unit. See Section 8 for generator relaying requirements.

ELECTRIC MOTORS:

See SECTION 8.

SWITCHGEAR AND MOTOR CONTROL CENTERS:

480V switchgear, where provided, shall be metalclad dead front, indoor, 600V class equipment with drawout air circuit breakers and shall contain the following:

1. Air circuit breakers to have adequate interrupting capacity when fed directly from station auxiliary transformer.
2. Potential and current transformers for metering and relaying.

480 V motor control centers shall be metal enclosed, dead front, NEMA Class II, Type B or C, equal to General Electric 8000 line and shall contain the following:

1. Air circuit breakers with adequate interrupting capacity when fed directly from station auxiliary transformer.
2. Motor starter and feeder circuit breakers of adequate quantity and size to supply all gas turbine auxiliary equipment.
3. Potential and current transformers for metering and relaying.

Three-phase ac circuit breaker panelboards shall have an adequate number and size of breakers to supply all equipment furnished.

125Vdc circuit breaker panelboard shall have an adequate number and size of breakers to supply all equipment furnished, plus a minimum of two 30-ampere or larger, two-pole breaker spare for Owner's future use.

BATTERY AND CHARGER:

Battery ratings shall be as follows:

1. 125Vdc.
2. Nominal 2.232V per cell.
3. Calcium-alloyed, lead-acid type.
4. Sized for 3 hours operation prior to recharging.

Charger ratings shall be as follows:

1. Input Voltage: 480V, 1 phase, 60 hertz.
2. Output Voltage: 125Vdc.
3. Output Current: Output as required carry continuous load plus recharge batteries in 6 hours.

#### TURBINE CONTROLS:

Provide a redundant microprocessor based control system to perform all control, monitoring, alarming, data logging, and communications associated with the turbine. Include local operator station, engineering workstation and remote operator station.

Control system shall include redundant communications to the plant DCS system.

The control system shall include the following functions:

1. Automatic startup and shutdown.
2. Speed/load control.
3. Temperature control.
4. Automatic synchronizing.
5. Monitoring and display of temperatures, flows, and pressures.
6. Speed, temperature, vibration, and flame protection.
7. Self diagnostics
8. Data graphing and trending.
9. Data historian.
10. Alarm logging.
11. Redundant sensors for critical points.
12. Graphical and tabular displays.
13. Remote communication.
14. System administrative functions and security.

Relaying and Metering:

1. See SECTION 8.2 for protective relaying requirements.
2. Provide hand reset lockout relays.
3. Meters and display for generator frequency, field current, field voltage, three phase current, three phase voltage, kW, kWh, kvar, kvarh, power factor, and switchyard voltage.
4. Complete automatic synchronizing equipment for generator breaker including synchronizing relay, synchronizing check cut-off relay, speed matching, and voltage matching relays.
5. Synchroscope, lamps, and switch.
6. Generator breaker control switch and lights.

#### WIRING:

The gas turbine, generator, and all auxiliary equipment shall be prewired to the maximum extent possible.

The interconnecting wiring between all equipment furnished, except as otherwise specified, shall be furnished and installed by this Contract.

All low-voltage wiring of 600 volts or less shall consist of insulated conductors installed in zinc-coated rigid-steel conduit.

1. Conduit shall be sized and installed in accordance with the requirements of the National Electrical Code.
2. Low voltage wiring shall conform to the requirements of SECTION 8.

All high-voltage wiring above 600 volts shall conform to the requirements of SECTION 8.

Appropriate power and control cable terminals shall be provided within the unit enclosure for external cable terminations. Arrange for grouped entrance of external control and low-voltage connections, and provide cable tray or wireway systems in unit for connection of all 600-volt wiring from point of entrance to internal equipment.

All devices for nominal 125Vdc operation shall provide satisfactory operation for a range of voltage of 100 to 140 volts with a 50°C ambient temperature.

All electrical devices and wiring located under the casing of the machine or at other high-temperature locations shall be specifically designed and constructed of suitable materials to give satisfactory operation in the high ambient temperatures involved.

Low-level instrumentation circuits shall be run in separate conduits. Instrumentation terminal points shall be isolated from other voltage levels.

### **5.2.6 Steam Turbine (STG) System**

Contractor shall provide a steam turbine generator unit complete with auxiliaries, appurtenances, and accessories, as required by the manufacturer and as specified herein, including all materials, services, and all required labor necessary for a complete functional installation, including all requirements for startup and testing.

Furnish the turbine generator unit complete with all piping between contiguous component parts, and with all wiring specified. All equipment and materials supplied shall be from manufacturers on the Approved Vendors List – Appendix B, unless approved by Owner. Contractor shall provide technical assistance and guidance for installation and placing the turbine generator unit into successful operation as specified.

Contractor shall provide technical review and coordination, shop inspection, expedition, shipping coordination, shipping inspections, receiving inspections, off-loading site storage and maintenance. Contractor shall submit an inspection program for Owner approval.

Design pressure, temperature and materials for all piping shall be based on the steam turbine manufacturer's standard, but not less than applicable ASME Boiler and Pressure Vessel Code and ANSI B31.1 requirements.

Contractor shall provide acoustical enclosures or lagging for noise control of the STG control valves to meet noise guarantees.

Applicable Codes and Standards: Design, fabricate, assemble, and test equipment so that upon installation and operation in accordance with manufacturer's recommended procedures for this application, the equipment will conform to the requirements of the applicable provisions of the standards including, but not limited to, the following or Engineer approved equivalent BS, ISO, or DIN standards:

1. American National Standards Institute (ANSI):
  - A. C1 - National Electrical Code (NEC)



- B. C42.1 - Definition of Electrical Terms, Group 10 Rotating Machinery
  - C. C50.10 - Rotating Electrical Machinery - Synchronous Machines
  - D. C50.13 - Rotating Electrical Machinery - Cylindrical Rotor Synchronous Generators
2. American Society of Mechanical Engineers (ASME):
    - A. Boiler and Pressure Vessel Code
    - B. B31.1 - Power Piping
    - C. TDP-1 - Recommended Practice for the Prevention of Water Damage to Steam Turbines Used for Electric Power Generation
  3. American Society for Testing and Materials (ASTM):
    - A. A194 - Carbon and Alloy Steel Nuts for Bolts for High-Pressure and High-Temperature Service
    - B. A437 -Alloy-Steel Turbine-type Bolting Material Specially Heat Treated for High-Temperature Service
  4. Institute of Electrical and Electronics Engineers (IEEE):
    - A. 4 - Techniques for High Voltage Testing
    - B. 421 - Criteria and Definitions for Excitation Systems for Synchronous Machinery
    - C. 421a Guide for Identification, Testing, and Evaluation of the Dynamic Performance of Excitation Control Systems
    - D. 421b - Synchronous Machines, High-Potential Test Requirements for Excitation Systems
  5. National Electrical Manufacturers Association (NEMA)
  6. Tubular Exchanger Manufacturer Association (TEMA)
  7. Hydraulic Institute (HI)

Experience: All equipment and material furnished shall have an acceptable history of satisfactory reliable service in central station use for a period of at least three years at comparable temperature, pressure, voltage, and design stress levels.

Newly-developed equipment with less than three years' actual service will be considered from established manufacturers, only if it has been adequately tested, meets the requirements of this Contract, and is approved by Owner.

Factory Tests and Reports:

Before shipment, conduct the following tests:

1. Turbine Tests:
  - A. Mechanical balance
  - B. Overspeed test of rotors with blades at not less than 120% rated speed
  - C. Governor and control function operation
  - D. All standard factory tests
2. Generator Tests:
  - A. Mechanical inspection
  - B. Rotor balance, with rotor at normal maximum operating temperature
  - C. Rotor overspeed at 120% rated speed
  - D. Measurement of cold resistance of stator and rotor windings
  - E. Winding insulation resistance measurement
  - F. Standard IEEE 4 dielectric tests on stator and rotor
  - G. Pressure test on hydrogen-cooled stator frame for gas tightness (if provided)
  - H. Resistance temperature detector test
  - I. For liquid conductor cooled stators, test for flow continuity through windings
  - J. All standard factory tests
3. Provide Owner a list of all factory tests and a test schedule so that a representative may witness the tests.

Results of tests shall be submitted to Owner for review. All factory test results shall be available for examination by Owner upon request.

#### 5.2.6.1 General

Provide each turbine generator unit with all accessories and features normally included with a unit for erection. Arrange equipment and appurtenances for safe and ready access for operation and maintenance. Provide access into enclosures and appearance lagging as required for operation and maintenance.

Provide adequate ventilation in enclosures and appearance lagging for proper cooling of equipment. Provide cooling systems, where required, for equipment that will not operate satisfactorily due to ambient temperature. Control, excitation, and supervisory equipment room will be air conditioned to an ambient temperature of 80°F; however, in case of failure of air conditioning, equipment shall operate satisfactorily at 100°F for continuous periods up to 48 hours, with peaks of 50°C for 3-hour periods during the 48 hours.

Provide couplings for fans, pumps, and other motor-driven equipment as follows:

1. All couplings shall be rated at not less than 140% of the motor horsepower.  
Flexible drive couplings shall be as follows:
  - A. Designed to prevent any external thrust from being transmitted to the driver shaft under normal operating conditions
  - B. Fast gear type, flexible disc type, or approved equal
  - C. Equipped with rainhood or cover for outdoor installations
2. Drive couplings shall have guards as follows:
  - A. Complying with all applicable state and federal safety requirements
  - B. Arranged for ease of disassembly or removal for access to coupling
  - C. Rigidly fastened to baseplate
  - D. Conform to other specific requirements of these Specifications, as applicable
3. Bolts, nuts, screws, and other standardized fasteners shall conform to the applicable ASTM A194 or A437 standards, except where higher standards for high temperature and pressure are deemed necessary by the manufacturer. Provide tools and wrenches for each nonstandard item.
4. Provide preservation and protection, suitable for overseas shipment and storage as specified in DIVISION 1. Submit description and details of preservation and protection systems and recommended storage procedures.
5. Unit shall be designed, constructed, and balanced statically and dynamically so that vibration displacement at the bearings at synchronous speed through full-load operation will not exceed Contractor's recommended operating limits.
6. Provide one set of electric bolt heaters, all special erection tools, lifting devices, special instruments, and other special equipment required for erection and installation of the unit. Provide metal storage cabinet for all special tools, wrenches, and instruments.
7. Provide temporary valve cover plates complete with pipe spools with weld end preps, and internal protective shields as required for main stop and reheat stop valves, for steam blowdown. Provide at least one complete set, suitable for use on up to eight turbines.
8. Provide lifting lugs to facilitate disassembly and maintenance. All piping that must be removed for overhaul of turbine shall be equipped with lifting lugs that protrude through the heat insulation. Provide a lifting beam so that the crossover piping (if applicable) can easily be removed as a single unit during disassembly.
9. Hanger assemblies, anchors, and sway braces shall be designed in accordance with the latest editions of the MSS Standard Practice SP-58 and SP-69. Design for seismic zone and building code specified in DIVISION 1.

### 5.2.6.2 Turbine

The turbine shall be of the multivalve, multistage type. Single governor valves are not permitted. All parts which are subject to temperature changes shall be designed and supported so as to permit free expansion and contraction in order to minimize distortion or misalignment.

#### Turbine Casings:

1. The casing shall be supported at the centerline, with flexible supports at the high-pressure end.
2. Provisions shall be made in the design of the turbine to control thermal stresses in the turbine casing.
3. Special provisions shall be made in all bolting 50 mm in diameter and larger for tightening.
4. The bearings shall be arranged to permit inspection without removal of the turbine casing.

#### Turbine Rotor:

1. The rotor shall be of forged construction, with wheels forged integrally with the shaft, as required by design operating conditions. Dovetailed grooves shall be turned in the wheels to securely hold the individual blades.
2. The completed turbine rotor shall be balanced in the manufacturer's plant in order to run smoothly and without excessive vibration.
3. Provisions shall be made in the design and manufacture of the rotor to minimize stress concentrations.

Turbine blading shall be stainless steel and shall be securely and adequately anchored and shall be readily renewable. Welding of blading to wheel disc will not be acceptable in any stage.

#### Diaphragms:

1. All diaphragm blading shall be of stainless steel.
2. Each diaphragm shall be split along the horizontal centerline and a doweled tongue and groove joint shall be provided to assure correct alignment and prevent interstage leakage.
3. The diaphragm halves shall be securely positioned in the casing of inner element.

#### Bearings:

1. All bearings shall be designed for pressure lubrication and shall operate without injurious temperature rise or undue wear.

2. All bearings shall be split to permit removal for inspection and shall be removable without removing the rotor.
3. All main bearings shall be provided with a positive visual check for oil flow through the bearings via sight flow indicators. Leakage of oil or oil vapors from the bearing housings shall be minimized.
4. A double-acting tilting pad, multisegment thrust bearing shall be provided to align and maintain the correct axial relationship between the rotating and the stationary parts.

All turbine drains and low point pipe drains will be piped to the condenser. The drain valve controls will be per the manufacturer's recommended design and in general accordance with ASME TDP-1.

Complete control and protective valve system including the following:

1. Main stop valves designed to withstand boiler hydrotest pressure of 1.5 times HRSG drum pressure.
2. Control valves automatically controlled by governor system.
3. Turbine anti-motoring sensor.
4. Devices as required for use with control and monitoring systems specified below to allow sequential remote testing of main stop valves, and control valves, while turbine is in operation.
5. Provide first-stage pressure sensor, for steam flow measurement.
6. Coarse mesh screens with removable fine mesh start-up screens, removable without disturbing inlet piping, or permanent fine mesh strainers, for main stop valves.
7. Proximity switches for main stop valves, and control valves, with two N.O. and two N.C. electrically separate pairs of contacts for Owner's use at each end of each valve mechanism with space for additional special switches specified below.
8. Hydraulic system trip interlock pressure switch with two electrically separate contacts for Owner's use, for tripping of generator and electrical auxiliary system upon tripping of turbine, if such tripping interlock scheme is recommended by the manufacturer. Provide indication of what caused the turbine to trip.
9. Power-operated drain valves, equipped with solenoid valves and limit switches on each valve if pneumatically operated, and piping between turbine and drain valves. Valves will be operated from the turbine control system. If motor-operated valves are furnished, provide position transmitters in addition to limit switches on each valve. Provide double valves at all steam drains above 400 psig. Where power-operated valves are provided, the first valve shall be manually-operated and provided with a locking device. High-pressure steam drain valves shall have the following:

- A. Pressure seal bonnet for valves 4 inches and larger, no bonnet or welded bonnet for valves 3 inches and smaller
  - B. Butt-welding ends for valves 2½ inches and larger, socket weld ends for valves 2 inches and smaller to 14% chromium steel trim
  - C. Stellite or 11.5 to 14% chromium disc and seat facings.
  - D. Integral stellite or 11.5 to 14% chromium back-seating surface
  - E. 600-, 900-, 1500-, or 2500- class cast steel or forged steel bodies, complying with applicable ANSI standards
  - F. Valves shall be manufactured by vendor listed in Appendix B – Approved Vendor List
10. Piping between main stop valves and turbine as required to locate valves either out from under the turbine and its foundation, or above its foundation, including all necessary hangers and supports for the valves and piping.

Exhaust casing spray nozzles with automatic control and internal turbine piping. Include diaphragm (or solenoid) control valve and sensing element for control.

Motor-operated or hydraulically operated turning gear including the following:

- 1. Turbine control system shall be capable of automatically starting and engaging turning gear.
- 2. Provide for local manual turning gear (or hydraulic oil pump) motor starting and turning gear engagement should the automatic feature fail.
- 3. Interlock with lubrication system to prevent operation without bearing lubrication.
- 4. Zero speed device to prevent automatic starting or engagement while rotor is turning.
- 5. Electrically separate alarm contacts to indicate zero speed and turning gear disengagement.

All required protective devices including the following:

- 1. Exhaust hood atmospheric relief diaphragms.
- 2. Exhaust hood high-temperature alarm.
- 3. Thrust bearing failure detector with trip function.
- 4. HP/IP Shell casing packing dump valve if required.

Provide all instruments required to monitor operation of the turbine unit. Instruments shall include at least the following:

- 1. Thermocouples for at least the following:

- A. Turbine shells, exhaust hoods, valve casings, and as otherwise required for controlled starting and warm-up
  - B. Thrust bearing shoes
  - C. Main bearing metal temperatures including generator bearings
  - D. Main bearing oil drains including generator bearings
  - E. Thrust bearing oil drains
  - F. Oil inlet and oil outlet of oil coolers
  - G. Hydraulic fluid in and out of coolers
  - H. Lube oil reservoir
2. Thermometers for at least the following:
- A. Main bearing drains including generator bearings
  - B. Thrust bearing drains
  - C. Exhaust hood
3. Pressure gauges for at least the following:
- A. Exhaust hood water spray
  - B. Gland condenser vacuum
  - C. Steam chest
  - D. First-stage steam
  - E. HP turbine exhaust steam
  - F. LP turbine exhaust steam
  - G. Gland steam header
4. Electronic pressure transmitters for the following:
- A. Lube oil header
  - B. Throttle (before stop valve)
  - C. Control valve chest (between stop and control valve)
  - D. Turbine First Stage
  - E. LP inlet stage
  - F. Turbine Exhaust
  - G. Electrohydraulic control fluid pressure

H. Gland steam pressure

5. Provide smart transmitters per the requirements in SECTION 9.

Rotor ground device and grounding pad on exhaust hood and/or bearing standard.

Heat retention insulation for the following:

1. Upper and lower turbine shells.
2. Steam valve bodies.
3. Exhaust casings where required.
4. All steam piping furnished with unit.
5. Horizontal and vertical joints. Provide reusable blankets.

Insulation jacketing as follows:

1. Aluminum jacket for all insulated piping.
2. Removable insulation-filled stainless steel covers for the following:
  - A. Main stop valves.
  - B. Valve flanges at turbine shells.
  - C. Flanges in crossover pipes.

Metal appearance lagging over HP turbine shells and associated stop and control valves and piping to shells.

Moisture protection system for low-pressure stages.

Exhaust connection suitable for welding to condenser neck.

Shims, subsole plates, leveling plates, seating plates, and sole plates.

#### 5.2.6.3 Electrohydraulic Control System

System shall automatically position the various valves listed above as required to control the turbine-generator speed and load under varying conditions plus trip the unit when overspeed or other abnormal conditions occur. Provide means to initiate and monitor sequential remote testing of the valves and other protective and trip devices during operation of the unit.

Hydraulic portion of the system shall be independent of lubricating oil system complete with reservoir, multiple ac motor-driven pumps, hydraulic fluid coolers, accumulators, filters, strainers, instruments, controls, valves, and all required supply and return hydraulic fluid piping to the main turbine.

1. Instruments and controls in the hydraulic portion of the system shall include at least the following:



- A. Suction and discharge pressure gauges on all pumps and on the discharge header.
  - B. Pressure switches for control of all electrohydraulic fluid pumps.
  - C. Thermometers on electrohydraulic fluid lines at the inlet and discharge of coolers.
  - D. Temperature controllers and cooling water control valves to regulate electrohydraulic fluid temperature at the discharge of each cooler.
  - E. Instrument and sensors to provide electrically separate alarm contacts for Owner's use for the following:
    - 1) Electrohydraulic fluid reservoir high level.
    - 2) Electrohydraulic fluid reservoir low level.
    - 3) Electrohydraulic fluid reservoir low-low level.
    - 4) Electrohydraulic fluid system low pressure.
    - 5) Electrohydraulic fluid temperature high.
    - 6) Electrohydraulic fluid system filters dirty.
    - 7) Others as required by the turbine supervisory and control systems.
  - F. Instruments and sensors as required by the turbine supervisory and control systems for operation of turbine.
- 2. All piping shall be stainless steel with welded joints and a minimum of flanged connections. Piping shall be cleaned internally and then sealed using weld caps or blind flanges before shipment.
  - 3. System shall use fire resistant fluid such as FYRQUEL or Owner approved equal.

#### 5.2.6.4 Turbine Control System

The control system shall provide supervisory control of turbines, turbine auxiliaries, generators, and generator auxiliaries. The system shall provide startup, operation, load change, and shutdown, as well as monitoring, alarming, and safety trips for steam turbine generator units.

The turbine control system shall be integrated into the plant DCS control system. The turbine control system shall be a subsystem of the plant DCS control system. All operator functions shall be capable from the plant DCS control system. Contractor shall provide a turbine control system that meets the following requirements and the DCS control system requirements in SECTION 9.

The turbine control system hardware will be installed in close proximity to the each steam turbine. Provide a remote operator station for the main control room and a local operator station for the electrical equipment room in each unit. Remote operator station shall have identical hardware and software as the local operator station.

Provide means to initiate and monitor sequential remote testing of the valves and other protective and trip devices during operation of the unit.

Provide all sensors, transducers, and transmitters required by the system.

Provide all control, logic and input-output modules, associated power supplies, and related items, installed in a system cabinet assembly, to perform the control functions specified herein.

Provide electrically separate alarm contacts for plant control system use for at least the following:

1. Turbine trip
2. Pre-trip and trip alarm contacts for every turbine trip condition
3. System power supply failure
4. Others as required or recommended by manufacturer

Provide capability of operating in any of the following modes as selected by the operator:

1. Coordinated Boiler-Turbine Mode using a load demand signal generated by Owner's automatic load dispatching system.
2. Coordinated Boiler-Turbine Mode using a load demand signal manually generated from DCS.
3. Boiler Following Mode with turbine valves maintaining speed or load.
4. Turbine Following Mode with turbine valves controlling throttle steam pressure.

Provide a hard wired interface from the turbine control system to DCS for all critical controls, indicators, and interlocks.

Provide controls to allow DCS to immediately reduce the load on the steam turbine generator. The immediate response of the system shall be impeded upon only by the constraints of the hydraulic system.

#### 5.2.6.5 Turbine Rotor Stress Monitoring

System shall automatically and continuously calculate rotor stresses that occur when temperatures change with machine loading.

System shall operate on the turbine control system hardware.

System shall be capable of operating in at least two separate modes. These modes are:

1. Monitor: In this mode, the system makes available to the operator data required for safe and proper operation of the turbine-generator unit. In this mode, system performs no control functions and all decisions regarding changes in speed or load, rates of change, and other variables are left to the operator.

2. Control: In this mode, the system shall automatically prevent the operator from changing unit load or turbine speed if limits established by the automatic control program or by the operator are exceeded. The system shall also be capable of automatically ramping the turbine from turning gear speed to a target speed, initiating a signal to automatically synchronize the turbine-generator unit, and loading the unit to a target load at a rate selected by operator or as limited by the automatic control program.

Provide all sensors and transducers required by the system.

#### 5.2.6.6 Turbine Supervisory System

System shall automatically monitor at least shaft vibration, vibration phase angle, eccentricity, differential casing and rotor expansion, metal temperatures, speed, and control valve position. Display essential values continuously and alarm any abnormal condition during start-up and operation.

Provide all sensors and transducers required by the system.

Display all information on the turbine control system interface and plant DCS display.

Provide alarms for at least the following:

1. High vibration for all bearings.
2. Rotor eccentricity off normal.
3. Differential expansion off normal.
4. Rotor position alarm.

#### 5.2.6.7 Lubrication System

The turbine lube oil system shall be installed, cleaned, and flushed according to the manufacturer's specifications. Lube oil type and purity shall be in accordance with the steam turbine generator manufacturer's specifications.

Provide a complete lubrication system including but not limited to the following:

1. Oil reservoir with oil level indicator and oil level alarms. Reservoir shall have adequate capacity above maximum lube oil high level alarm to receive the flowback from the lube oil system under tripout conditions
2. Full-capacity positive-displacement or centrifugal-type main oil pump, either shaft-driven or with ac motor drive
3. Full-capacity positive-displacement or centrifugal-type auxiliary oil pump with ac motor drive
4. Positive-displacement or centrifugal-type emergency oil pump with dc motor drive and starter
5. Oil coolers, either two full-capacity or one three-section type with two sections capable of carrying full capacity

6. Transfer valve so that one tube bundle or section can be removed while remaining cooler or sections are in operation
7. Vapor extractor with ac motor drive
8. Lube oil demister
9. Removable strainers for use during start-up at each bearing inlet and at oil return to reservoir, and at other locations as required by manufacturer
10. Lube oil heater interlocked with a low oil reservoir liquid level switch for alarm and to trip the heater to prevent a fire

Provide instruments required for operation. Instrument signals shall be integrated into the turbine control system. Instruments shall include at least the following:

1. Pressure gauges on all pump suction and discharge lines and on the lube oil header
2. Pressure switches for control of all lube oil pumps
3. Thermometers on oil lines at the inlet and discharge of lube oil coolers
4. Thermocouple complete with well for control of cooling water flow
5. Lube oil reservoir level high
6. Lube oil reservoir low level switch
7. Lube oil reservoir level transmitter
8. Differential pressure switch across filters
9. Emergency lube oil pump running
10. Redundant pressure switch to start dc emergency oil pump. Switch shall be located at a different location from the other pressure switch.
11. Others as required by the turbine control system
12. Loss of ac power relay to start dc emergency pump

Provide all required lube oil supply and return piping. Oil pressure piping shall be seamless steel with welded joints, and a minimum of flanged connections. Oil piping shall be thoroughly cleaned by pickling and then sealed using weld caps or blind flanges before shipment. For protection against fire, oil piping shall be suitably shielded with no flanged joints located above or adjacent to hot surfaces. All lubricating oil piping under pressure in high temperature areas shall be contained within a drain or return line, or within a tight housing which is suitably drained back to a reservoir. Drains shall have adequate capability of returning the oil supplied to any area in the event of a complete rupture of the oil supply pipe in that area. All drain pipes shall be sloped to provide complete drainage of the system back to the lubricating oil reservoir.

#### 5.2.6.8 Gland Steam System

Provide a complete gland sealing system including but not limited to the following:

1. Steam seal pressure control valves, one for each steam source and one for dump to condenser
2. Full-flow gland steam condenser with two ac motor-driven exhausters, both permanently mounted to the condenser
3. Power-operated diaphragm shutoff and bypass valves with remote position indicators as required to manually control gland steam from the turbine control system should regulators fail
4. Valves and all required piping from pressure control valves to turbine and from turbine to gland condenser
5. The gland sealing system shall have the following features:
  - A. The gland sealing system shall not require an external source of steam other than main steam at throttle conditions, or drum steam after pressure reduction. An auxiliary supply of saturated steam shall be provided by Contractor to seal the turbine prior to start-up.
  - B. Gland leakage shall be returned to the cycle by the gland sealing system provided, except such portions as may be contaminated by air or oil vapor.
  - C. Gland steam valves shall be of an Owner-approved type with stellite or 11.5 to 14% chromium seats.
  - D. Provide removable flanged spool piece at each connection to the turbine gland seal piping to facilitate steam cleaning of the gland steam system in accordance with the manufacturer's recommendations.
6. Provide all instruments required for operation. Instrument signals shall be integrated into the turbine control system. Instruments shall include at least the following::
  - A. Low steam seal pressure switch
  - B. High water level switch in gland steam condenser
  - C. Gland steam temperature sensor

#### **5.2.7 Combustion and Steam Turbine Electrical Generator**

##### 5.2.7.1 General:

Generator shall be cylindrical rotor type designed, constructed, and rated in accordance with applicable standards for specified service conditions.

The steam turbine generators will be connected to the delta wound primary of the Generator Step-up (GSU) Transformer. The secondary of the GSU will be solidly

connected grounded type wye configuration. The unit will be synchronized across the high side switchyard breaker. See SECTION 8 for additional requirements.

The gas turbine generators will be connected in a high resistance grounded wye configuration through a neutral grounding transformer with neutral grounding resistor connected to transformer secondary. The generator will be connected to a low side generator breaker that is connected to the low side of the GSU. The unit will be synchronized across the low side breaker. See Section 8 for additional requirements.

#### 5.2.7.2 Applicable Codes and Standards

Design, fabricate, assemble, and test equipment so that upon installation and operation in accordance with manufacturer's recommended procedures for this application, the equipment will conform to the requirements of the applicable provisions of the standards (or equivalent IEC standards) including, but not limited to, the following:

1. American National Standards Institute (ANSI):
  - A. B31.1 - Code for Pressure Piping - Power Piping
  - B. C1 - National Electrical Code
  - C. C42.1 - Definition of Electrical Terms, Group 10 Rotating Machinery
  - D. C50.10 - General Requirement for Synchronous Machines
  - E. C50.13 - Cylindrical Rotor Synchronous Generators
  - F. C57.13 - Requirements for Instrument Transformers
2. American Society of Mechanical Engineers:
  - A. Boiler and Pressure Vessel Code
  - B. B31.1 - Power Piping
3. American Society for Testing and Materials (ASTM):
  - A. A194 - Carbon and Alloy Steel Nuts for Bolts for High-Pressure and High-Temperature Service
  - B. A437 - Alloy-Steel Turbine-Type Bolting Material Specially Heat Treated for High-Temperature Service
4. Institute of Electrical and Electronics Engineers (IEEE):
  - A. 4 - Techniques for Dielectric Tests
  - B. 21 - Outdoor Apparatus Bushings, General Requirements and Test Procedure
  - C. 32 - Neutral Grounding Devices
  - D. 421 - Criteria and Definitions for Excitation Systems for Synchronous Machinery

- E. 421a - Guide for Identification, Testing, and Evaluation of the Dynamic Performance of Excitation Control Systems
- F. 421b - Standard for High-Potential Test Requirements for Excitation Systems for Synchronous Machines
- 5. National Electrical Manufacturers Association (NEMA).
- 6. Tubular Exchanger Manufacturer Association (TEMA).

#### 5.2.7.3 Quality Assurance

All equipment and material furnished shall have an acceptable history of satisfactory reliable service in central station use for a period of at least three years at comparable temperature, pressure, voltage, and design stress levels.

Newly-developed equipment with less than three years' actual service will be considered from established manufacturers, only if it has been adequately tested, meets the requirements of this Contract, and is approved by Owner.

#### 5.2.7.4 Factory Tests

All standard factory tests on equipment and all tests required by the applicable codes shall be performed including:

Mechanical inspection.

1. Rotor balance, with rotor at normal maximum operating temperature.
2. Rotor over-speed at 120% rated speed.
3. Measurement of cold resistance of stator and rotor windings.
4. Winding insulation resistance measurement.
5. Standard IEEE 4-1978 dielectric tests on stator and rotor.
6. Pressure test on hydrogen-cooled stator frame for gas tightness (if provided).
7. Resistance temperature detector test.
8. For liquid conductor cooled stators, flow continuity through windings.
9. Lubricating systems including hot oil flushing and bearing inspection.
10. Comprehensive tests of all systems and controls to assure proper assembly and connection, including simulation tests of all safety devices.

Provide Owner and Engineer a list of all factory tests and a test schedule so that they may have a representative witness the tests, if desired.

Submit certificate of completion of all tests and test reports for all tests. All factory test results shall be available for examination by Owner upon request.

#### 5.2.7.5 Submittals

Submittals required shall include all manufacturer's drawings necessary for design, installation, and operation of equipment furnished, including the following:

1. General outline, base plans, and general arrangement drawings
2. Detailed installation drawings showing foundation details, location connections, weights, and all clearances required for erecting, operating, and dismantling
3. Complete loading diagrams covering static and dynamic loadings for all conditions of operation
4. Schematic wiring diagrams showing all external connection terminal block numbers
5. Complete connection diagrams showing all internal wiring
6. Power and instrument transformer connection and polarity diagrams
7. Instrument transformer performance curves and data
8. Bills of material
9. Drawings showing additional detail if requested by Engineer, or if otherwise required for installation and maintenance

Wiring drawings shall include connection drawings both internal and external, NEMA Standard across-the-line industrial control schematic drawings for all control systems provided or designed by Contractor, physical location drawings for all terminal blocks, and power requirements.

#### 5.2.7.6 Products

GENERAL: Generator stator core shall be so designed and constructed (or flexibly mounted) as to minimize the effects of 120-cycle vibrations on stator frame, foundation, and other structures.

#### GENERATOR:

1. Minimum net continuous rating of 105% of the turbine peak output at 85% lagging to 95% leading power factor
2. General output voltage  $\pm 5\%$  of nominal
3. TIF maximum (1960 weighting), balanced: 40
4. TIF maximum (1960 weighting), residual: 30
5. Minimum short circuit ratio at rated hydrogen pressure: 0.5.

#### COOLING SYSTEM:



1. Generator cooling system shall be totally enclosed hydrogen cooled or Totally Enclosed Water Air Cooled (TEWC) with Class F insulation on stator and rotor and limited to Class B temperature rise.
2. The internal generator cooling air shall be adequately filtered and controlled to permit operation without adverse effects on the service life of the insulation or condensation and corrosion of generator iron.

EXCITATION SYSTEM:

1. Provide self-excited main exciter of brushless or static type, having stabilized voltage.
2. Provide control system with fast-acting response, and suitable voltage regulator arranged for local and remote control.
3. Provide excitation control breaker and field discharge or field suppression contactor and resistor.
4. Provide all necessary current transformers, potential transformers, relays, protective devices, and supervisory safety monitoring devices.
5. Exciter shall be capable of supplying 110% of nominal rated field continuously and 150% ceiling current for a minimum of 30 seconds.
6. Generator excitation equipment shall be housed in a metal-enclosed NEMA dead-front enclosure and contain the following:
  - A. Excitation control circuit breaker or field suppression control
  - B. Linear field discharge resistor if required
  - C. Voltage regulator
  - D. Ammeter shunt
  - E. Regulator shall be equipped with tie-line power factor compensation, cross-current compensation, and maximum and minimum excitation limits
  - F. Provisions to interface with distributed control system (DCS) for remote reactive power and voltage control.
  - G. Redundant hot back-up thyristor bridge.
7. General:

All excitation system voltage response ratios stated herein are to be as defined and recommended in IEEE 421, and shall be determined with the excitation system connected to the generator field, or an equivalent resistive load as described by IEEE 421a. A factory test or an analytical method may be used in determining acceptance of the voltage performance.
8. Provide a complete excitation system of one of the following types:

- A. Static type including the following:
    - 1) Provide separate dry-type power potential transformer in a free-standing metal enclosure provided with high voltage bushings and flanges for connection to isolated phase bus duct. Overcurrent relay and associated CTs for transformer protection shall be provided.
    - 2) Collector enclosure with internal illumination, hinged access doors, observation windows, and ventilation system.
    - 3) Metal-enclosed excitation cubicles with voltage regulator, generator supply breaker, field ground detector, silicon rectifiers, and all required control circuits and accessories.
  - B. Brushless rotating rectifier type including the following:
    - 1) Permanent magnet pilot exciter, ac exciter, and a diode and fuse wheel directly connected to the generator shaft. Each diode must have series fuse.
    - 2) Exciter enclosure with internal illumination, hinged access doors, observation windows, and cooling system.
    - 3) Metal-enclosed excitation cubicles with voltage regulator, exciter supply breaker, automatic field ground detector, and all required control circuits and accessories.
    - 4) Furnish an excitation system communication interface to the plant distributed control system to allow operator to monitor and control the excitation system.
9. Provide the following special excitation system features:
- A. Ten additional auxiliary contacts on exciter field breaker. This may be by the addition of a multi-contact auxiliary relay
  - B. Provide field ground detection relays for main generator and exciter field
  - C. Fuses and terminal blocks for all components of excitation system requiring 120 volts ac or 125 volts dc station service power
  - D. Line drop compensation for voltage regulator
  - E. Maximum and minimum excitation limit equipment
  - F. Two-step maximum volts per hertz excitation protection and limiter
  - G. Provisions for the addition of supplemental excitation controls to control excitation in response to generator rotor angle
  - H. Dual input power system stabilizer utilizing integral of accelerating power with system studies, settings, and field tuning

- I. Provide main generator field ground detection relay with proper sensitivity and adequate security to use to trip the unit. Provide unit with time delay to prevent trip for momentary field ground
- J. Automatic regulator tracking control for manual regulator.
- K. Regulator and power system stabilizer output status contacts to Owner's SCADA system
- L. Provide transducers with 4 to 20 mA output to Owner's DCS for exciter field voltage and current.
- M. Hydrogen/temperature Limiter Compensation.
- N. Overvoltage trip.
- O. Provide field overcurrent protection system that has characteristics similar to the thermal capability of the rotor so as to permit full utilization of the rotor thermal capability, but that will positively prevent overcurrent which could damage the rotor, An offline field current limiter shall be provided
- P. Field flashing system for operation using station 125V battery, or separate 460-volt, 3-phase system
- Q. The exciter ceiling voltage shall be based on a response ration of 2.0. Power factor and VAR automatic control.
- R. Communication ports to Owner's DCS.
- S. Off line excitation protection.
- T. Display panel with self diagnostics

HYDROGEN SYSTEM: (As applicable if provided by OEM for cooling)

- 1. Provide hydrogen coolers arranged and sized with adequate capacity to provide 80% generator capability with one isolatable cooler, or section (as applicable), out of service. All fasteners (nuts, bolts, and similar items) exposed to the cooling water shall be stainless steel. Arrange cooler vents for convenient access below the operating floor
- 2. Provide hydrogen bottle manifold including pressure gauges, shutoff valves, mounting brackets, bottle connectors, piping and a single shutoff valve. Provide a flanged removable section of pipe between the hydrogen shutoff valve and generator for removal while performing generator maintenance.
- 3. Provide carbon dioxide and nitrogen bottle manifolds including pressure gauge, shutoff valves, mounting brackets, bottle connectors, and single shutoff valve.
- 4. Provide piping, valves, regulators and analyzer as follows:
  - A. Generator hydrogen pressure regulator with shutoff valves and bypass line
  - B. Purging control valve assembly

- C. Purging gas analyzer
  - D. Welded steel gas control system piping
5. Provide instrument and controls as follows:
- A. Electronic transmitters as follows:
    - 1) Generator hydrogen purity
    - 2) Generator hydrogen pressure
    - 3) Generator fan differential pressure
    - 4) Hydrogen density
    - 5) Hydrogen dewpoint
  - B. Sensors as required to provide at least the following alarms at the hydrogen controls cabinet.
    - 1) Generator hydrogen purity high and low
    - 2) Generator hydrogen pressure high and low
    - 3) Hydrogen supply pressure low
    - 4) Generator hydrogen temperature high
    - 5) High Hydrogen dewpoint
    - 6) Others as required by manufacturer
  - C. Temperature detectors to include the following: (Detectors listed below are for Owner's use. Any that are required by the turbine control or supervisory system dual detectors shall be furnished.)
    - 1) One RTD for each hydrogen cooler gas inlet and outlet.
    - 2) One thermocouple and well in combined gas stream on the outlet of coolers for control of Owner's cooling water valve.
    - 3) Two RTDs in combined gas stream on the outlet of hydrogen coolers.
6. Provide hydrogen control cabinet including the following:
- A. Generator hydrogen pressure indicator.
  - B. Generator hydrogen purity indicator.
  - C. Fan differential pressure indicator.
  - D. Generator gas density indicator.
  - E. Generator cold gas temperature indicator.

- F. Seal oil differential pressure indicator.
  - G. Stator coils water flow indicator, if applicable.
  - H. Stator coils water tank pressure indicator, if applicable.
  - I. Stator coils water pressure differential indicator, if applicable.
  - J. Conductivity recorder for conductor liquid cooling system (if applicable).
  - K. Hydrogen system SCAM-Panalarm Series 80 solid-state annunciator or
  - L. Engineer's approved equal with isolated alarm contact output for each window for Owner's use.
  - M. Complete internal panel piping and wiring.
  - N. Provide space heater and thermostatic alarm control for auxiliary panels.
7. Redundant trains shall have isolation valves to allow maintenance with one train out of service.

MISCELLANEOUS:

1. Provide the following materials equipment and instruments:
  - A. Six high-voltage bushings
  - B. Temperature detectors to include six RTD's per phase embedded in stator windings
  - C. Generator field flux probe permanently mounted
  - D. Field retaining ring Material shall be 18 Mn 18 Cr
  - E. Partial Discharge Detectors mounted in stator slots
  - F. Fiber optic end winding mounted accelerometers
  - G. Grounding pads
  - H. Terminals for testing bearing and seal housing insulation on at least one
    - I. generator bearing and both bearings of a rotating exciter
  - J. Foundation plates, shims, and sub-sole plates
  - K. Metal appearance lagging from floor to centerline of generator
  - L. Set of lifting slings, special tools and wrenches, air gap shim, and field shoe for assembly of rotor, and one set of lifting or jacking trunions
  - M. Generator casing liquid detector
  - N. Bushing current transformers shall be as follows:

- 1) Provide bushing current transformers as required for relaying and metering
  - 2) Bushing current transformers shall meet ANSI accuracy class of C-800 for relaying, or 0.3B1.8 for metering
- O. Bushings designed and arranged for termination of isolated phase bus duct
  - P. Neutral terminals shall be interconnected and completely enclosed in a properly ventilated enclosure with provision for connection to neutral grounding equipment
  - Q. Field temperature indicator transmitter including field current shunt in dc bus, if applicable
  - R. Vibration monitoring probes
  - S. Generator balanced voltage wave shape shall limit the open circuit telephone influence factor to the current standards, based on 1960 weighting factors, or provide at no additional cost all necessary accessories with isolated phase construction required to meet the standards
  - T. Generator stator and windings, including series loops and end turns (end turns not fully insulated on gas-cooled stators), shall be fully insulated so as to be satisfactorily tested in accordance with the high potential tests required by IEEE Standard 4, and in a manner satisfactory to Engineer. Contractor shall submit details of insulation for review and approval prior to award of Contract

HEAT EXCHANGERS:

1. Exchangers with water source from treated raw water:
  - A. Tubes shall be 20 BWG minimum, stainless steel
  - B. Tube sheets shall be Contractor's standard
  - C. Channels and cover plates shall be aluminum bronze
  - D. Water sides of coolers to be designed for the pressure and cooling water temperature as required by Contractor's design
  - E. Minimum tube size shall be 5/8 inch nominal diameter

Exchangers in condensate cycle (Refer to SECTION 5):

  - A. Tubes shall be adequate for design pressure as required by Contractor's design
  - B. Tubes for gland steam condenser shall be stainless steel
  - C. Tube sheets shall be Contractor's standard material
  - D. Channels shall be fabricated steel

- E. Designed for the water temperature ranges as required by Contractor's design
  - F. Minimum tube size shall be 5/8 inch nominal diameter
2. Exchangers in bearing cooling water system (Refer to SECTION 5):
- A. Designed for design pressure and temperature as required by Contractor's design
  - B. Tubes shall be stainless steel minimum 22 BWG
  - C. Tube sheets shall be Contractor's standard material
  - D. Channels shall be fabricated steel
  - E. Minimum tube size shall be 5/8 inch nominal diameter

ELECTRICAL DEVICES:

- 1. Electric indicating instruments shall be semi-flush mounting, long-scale type, 5-inches square with black metal case, General Electric type AB-40 or DB-40.
- 2. Position and limit switches shall be suitable and adequate with mountings and actuators as required to provide reliable operation.
- 3. Alarm switches shall have contact ratings of at least 0.25 amperes at 125 volts dc and shall close for alarm.
- 4. All control devices such as relays and solenoids for nominal 125-volt dc operation shall provide satisfactory operation for a range of voltage from 90 to 140 volts with a 50°C ambient temperature where obtainable.
- 5. All electrical devices and wiring located under the casing of the machine shall be specifically designed and constructed of suitable materials to give satisfactory operation in the high ambient temperatures involved.
- 6. All electrical equipment and devices furnished on the turbine generator unit and its auxiliaries shall be wired out to conveniently located, oversized, terminal boxes for Owner's external wiring connections. Terminal boxes shall be NEMA 12. Terminals shall be marked as designated by Engineer.
- 7. Motors shall conform to SECTION 8 and the following:
  - A. Size motor to operate at less than nameplate horsepower over the capability range of the driven equipment
  - B. Motor insulation shall be NEMA Class F, with Class B temperature rise in accordance with NEMA MG1
  - C. Suitable for across-the-line starting
  - D. Provide TENV or TEFC enclosures for all motors

8. Provide disconnect-type combination motor starters, completely wired, for all dc motor-driven auxiliaries provided by this Contract.

CONTROL PANEL EQUIPMENT:

1. Construction:
  - A. Provide panels and cabinets, totally enclosed, self-supporting
  - B. Provide hinged access doors and/or removable panels as required
  - C. Factory mount all instruments, control switches, and other devices at locations approved by Engineer
  - D. Smooth, fill, prime and paint panels with two coats of finish paint of manufacturer's standard color subject to the approval of Engineer
  - E. Wire and tube completely in factory
  - F. Provide panels or insert panels to match Owner's panels provided under other contracts
2. Panel Wiring Terminal Blocks:
  - A. Terminate all connections requiring external wiring at terminal blocks, suitable for ring-tongue type connectors
  - B. Identify each terminal on each block by stamping or painting the circuit identification number
  - C. Provide manufacturer's standard terminal blocks subject to approval of Engineer
3. Panel Wiring:
  - A. Wire with no splices and with all connections made on equipment studs or terminal blocks. Make all connections with insulated, ring-tongue terminals
  - B. Provide General Electric type SIS Specification SI-57275, or standard conductor switchboard wire insulated for 600 volts
  - C. Provide extra flexible hinge wire in areas subject to flexing such as hinged panels and doors
  - D. Install in wiring troughs or channels with removable covers for easy accessibility to interior panel wiring

GENERATOR SURGE PROTECTION AND POTENTIAL TRANSFORMER EQUIPMENT:

1. Ratings:
  - A. Potential Transformers:
    - 1) Voltage and BIL as required, 60 Hz.



- 2) Thermal capacity of at least 1000-volt amperes and metering accuracy of 0.3 for burdens W, X, Y, Z, and ZZ, when applied at rated voltage.
- 3) Thermal capacity of at least 580-volt amperes and metering accuracy of 0.3 for burdens W, X, Y, and J.6 for burden Z, when connected line-to-neutral.

B. Surge Arresters:

- 1) Proper rating design for rotating machine protection of the generator. Furnish an operation counter with each arrester.

C. Surge Capacitors:

- 1) Rated for the application and sized at 0.25 micro farads or as recommended by manufacturer.
- 2) Provide with dual secondary windings: One winding connected in a wye configuration and the other connected in an open delta configuration.
- 3) Provide loading resistors across secondaries.

2. Type and Design:

- A. Equipment will be located in line terminal cabinet and will be drawout type connected wye-wye, with current limiting primary fuses, secondary fuses, and necessary primary and secondary disconnecting devices and connections. Transformers shall be designed and constructed in accordance with ANSI C57.13.
- B. Surge arresters to be metal-oxide station type, General Electric Tranquell or Ohio Brass Dynavar.
- C. Furnish complete NEMA 2 steel enclosure cubicle with floor plate for above equipment with necessary primary and secondary connections, wiring, terminal blocks, and insulator supports and mounted on I-beam base so as to be self-supporting when resting on concrete floor or foundation.
- D. Furnish flanged connection with seal-off bushings at equipment enclosure and non-segregated bus extension to generator terminal enclosure.
- E. Furnish a ground bus at least 1 inch by ¼ inch cross section to the full width of each enclosure. Furnish connector for 250-MCM copper cable at each end of each ground bus.
- F. Arrange for entrance of external secondary circuit wiring from below.
- G. Surge capacitors and transformers shall not contain any PCB insulating fluid.

GENERATOR NEUTRAL GROUNDING EQUIPMENT:

1. Ratings:

- A. As recommended by Contractor

- B. Voltage as required, 60 Hz, 110-kV BIL
- 2. Grounding Resistor:
  - A. Sized for high resistance ground system
  - B. Voltage rating suitable for connection to 220-volt transformer secondary
- 3. Type and Design:
  - A. Transformer to be sealed dry type 300°F rise
  - B. Resistor to be cast-grid or stainless steel type
  - C. Furnish steel enclosure for housing transformer and resistor, with full height, hinged access doors, floor plate, and I-beam base so as to be self-supporting when resting on concrete floor or foundation. Provide adequate ventilation louvers in enclosure
  - D. Include wiring to terminal block in terminal compartment or cabinet for remote relaying connections, arranged for wiring entrance from above
  - E. Furnish connectors on transformer terminals and other provisions for connection of cable from generator neutral terminals, and for two connections to station ground grid by 250-MCM copper cable

**GENERATOR TERMINAL ENCLOSURE:**

- 1. Furnish one terminal enclosure.
- 2. Construct enclosure of heavy-gage sheet aluminum with internal stiffeners as required for rigidity.
- 3. The enclosures and/or the terminal attachment flanges at the top, should be able to accommodate an approximate construction variation in the calculated bus centerline-to-terminal vertical and horizontal distances of plus or minus 3/4-inch
- 4. Construct with large removable access covers to permit removal and replacement of the disconnect links at the main terminals.

**ACCESSORIES:**

- 1. Provide generator with at least six stator temperature detectors of resistance type, 100 ohms at 77°F, and at least two temperature detectors to measure cooling air inlet and discharge temperatures wired to terminal box.

**5.2.8 Heat Recovery Steam Generator (HRSG) System**

Contractor shall provide two (2) complete and functional HRSGs including all materials and labor required to design, fabricate, install, startup, and test the HRSGs. The HRSGs shall be a three pressure, natural circulation, water tube type designed for gas turbine exhaust. Each HRSG shall be complete with inlet ductwork from combustion turbine exhaust connection, including expansion joint, HRSG exhaust duct, and exhaust stack.

The HRSG process design concept is illustrated in Heat Balances and Conceptual Process Flow Diagrams, Appendix D. The HRSG shall be designed and constructed in compliance with the ASME Boiler and Pressure Vessel Code, Section I and NFPA 85.

The Scope of Supply shall include but not limited to the following:

1. Two complete modularized Heat Recovery Steam Generators
2. Inlet ductwork from combustion turbine exhaust, with expansion joint including gasket, bolts and nuts.
3. HRSG exhaust duct with expansion joint, including gaskets, bolts and nuts.
4. Individual Exhaust Stacks with test ports and CEM monitor ports
5. Motor actuated stack dampers
6. Internally insulated HRSG casing with complete liner.
7. Triple pressure HRSG with HP, IP, & LP drums, superheaters, evaporator and economizer sections, superheater attemperators, reheater attemperators.
8. Complete Duct burners system including all required piping, valves, instruments and complete PLC based burner management system. (Contractor option)
9. Selective catalytic reduction (SCR) system, including vaporization skid, piping, valves instrumentation, ammonia injection grid and catalyst, also CO catalyst
10. HP, IP, and LP Drum end enclosures
11. LP economizer recirculation pumps, valves, piping and temperature control system.
12. Galvanized access platforms, ladders and stairways. Ladders shall be located on one side of the HRSG with platforms and stairways located on the opposite side.
13. All structural steel supports to grade for ductwork and stack, as required.
14. All vents, drains, Blowdown, chemical feed connections.
15. All Steam safety valves with silencers vent piping to meet noise requirements specified in Section 1. Vents to be a minimum of 15 ft above the highest platform.
16. All safety valve above seat drains and drip pan drains shall be routed to a safe area.
17. Each heat transfer section shall be completely drainable and ventable. All valves that must be opened or closed as a part of startup, shutdown or transient conditions shall be power operated. All other vents & drains shall have manual valves. Drain valves shall be located at grade.
18. Continuous and Intermittent blowdown piping and power operated valves. Blowdown system shall not be a cascading system. Blowdown shall be routed to dedicated blowdown tanks for each HRSG.
19. Sample connections shall be provided for the water and steam from the HP, IP, and LP steam drums, reheater outlet, LP economizer inlet, and LP economizer outlet.
20. All piping between equipment and components furnished with the HRSG.

21. Temperature test connections (including thermowells) shall be provide for monitoring temperature of water inlet and outlet of each heat transfer sections.
22. Two (2) valved test connections on HRSG gas-side between each heat transfer section.
23. Stainless steel chemical feed connections with check and isolation valves for the HP and IP steam drums.
24. Complete set of all controls and instrumentation including, but not limited to, steam flow elements, temperature well, thermocouples, and transmitters.
25. Each HRSG shall be provided with a monorail and powered hoist and trolley with a stainless steel cable, rated for routine maintenance, and installation and removal of SCR catalyst.
26. Technical advisors for field installation and erection, finish painting, boilout, hydrostatic testing, startup and testing of the HRSG, SCR system and all auxiliaries, including all electrical raceways, cables, and any other equipment or special accessories and services required for a complete installation.

Each HRSG shall be capable of a full range of plant continuous operation between each of the following cases, at the design ambient temperature ranges:

1. 50% CTG load, single unit operation
2. Base CTG load with maximum duct firing, single unit operation
3. 50% CTG load, two unit operation
4. Base CTG load with maximum duct firing (if provided), two unit operation

#### 5.2.8.1 General

All portions of the heat recovery steam generator shall be drainable. Provide drain system sized such that the drum, economizer, superheater, tubes, headers and piping can be drained in a maximum of 2 hours. Vents shall be provided on all sections of the HRSG. All high pressure vents that must operate during normal start-up and/or shutdown shall include silencers. Design for adequate circulation through all tubes and heating surfaces to prevent overheating of any area under any load and all operating conditions. HRSG shall be designed to allow operation with a floor pressure of 750 psia at all operating conditions (including 1x1 operation) with the CTG at 50% load, HRSG unfired, and with the CTG at base load, maximum HRSG firing and power augmentation.

#### 5.2.8.2 Pressure Parts

Design all pressure parts for safe operation at the outlet pressure specified at all loads. Provide for expansion and contraction so that tube alignment and spacing is not affected. Furnish airtight seals as required to prevent leakage.

Provide all necessary connections for chemical cleaning operations and access to headers for tube flushing, including access through casing and insulation.

All evaporator or economizer tubes shall be electric resistance welded and shall conform to the requirements of the ASME Boiler and Pressure Vessel Code. All reheater and superheater tubes shall be seamless drawn and shall conform to the requirements of the ASME Boiler and Pressure Vessel Code. Tubes shall be extended-surface type with continually welded fins. HRSG tubes shall be a minimum wall thickness of 0.105 inches with a 0.001 Hr-ft<sup>2</sup> °F/Btu fouling factor on both the gas side and the steam side. Tube arrangement shall facilitate cleaning and inspection without cutting of pipe. For inspection purposes, one turn in each coil shall be provided with a flanged inspection port. There shall be no more than 7 fins per in. Fins shall have a thickness of at least 0.060 inches, and shall be no more than 3/4 in. high. Fin connection to tubes shall utilize continuous high frequency welds. Provide baffles and tube supports as required to prevent acoustic vibration of tubes. No vaporization of feedwater shall take place within the economizer tubes throughout the entire operating range. Tubes shall be arranged for ease of removal and replacement of an individual tube with a minimum of disturbance to all other tubes.

Fin materials shall be as follows:

1. Carbon steel for fin tip temperatures up to 800° F.
2. Material similar to ASME 409 SS for fin tip temperatures up to 1000°F.
3. Material similar to ASME SA 213 Grade TP304 or TP316 for fin tip temperatures up to 1500°F.

Tube materials shall be carbon steel for tube temperatures up to 800°F and ASME SA213 Grade T22 for tube temperatures up to 1000°F and ASME SA213 Grade T91 for tube metal temperatures greater than 1000°F.

Superheater shall be designed to provide for uniform distribution of steam at all loads. Pressure drop shall not exceed 5% of maximum steam pressure at maximum steam flow, without Owner approval.

#### 5.2.8.3 Boiler

Design for adequate circulation through all tubes and heating surfaces to prevent overheating of any area under any load and all operating conditions.

Tubes shall enter a drum or header normal to its surface. Hillside connections on headers are an acceptable alternative. The tubes shall be designed and arranged to provide for natural circulation in the proper direction at all loads.

Headers shall be seamless drawn steel pipe or fabricated from formed steel plate with welded construction. Headers shall have seal welded plug-type handholes, welded capped inspection nozzles, or other type as approved by Engineer, as required for inspection. Inspection handholes or nozzles shall be in accessible locations.

Boiler lower drains shall be provided with chemical-cleaning connections.

Connections for use by Owner shall be welding connections conforming to ANSI/ASME B16.25.

If headers are within the gas stream, they shall be designed as heat absorbing surfaces and shall not be insulated. Headers shall be adequate for the gas temperature encountered without allowance for internal steam cooling. Lower headers shall allow for steam pecking to maintain higher temperature when the unit is off line.

Provide drums and headers with nozzles as required for vents, drains and instruments. Nozzles shall extend beyond the header insulation; size and weld-end preparation of nozzles for Owner's connection shall be subject to the approval of Engineer.

External casing shall be gas-tight, continuously seal welded construction and provided with packing at all piping penetrations and expansion joints. Construct casing of a minimum of ¼ inch thick A-36 carbon steel. Continuously weld all external stiffeners to the casing. Casing stiffeners shall be evenly spaced, horizontal or vertical, resulting in a uniform pattern and subject to approval by Owner. Provide 18 inch x 24-inch minimum bolted and gasketed access doors upstream and downstream of each tube bundle on both sides of the HRSG, in each transition, and as required to provide complete access to all components for maintenance and inspection.

Maximum bundle depth for all bundles shall be 12 tubes. Minimum access space between bundles shall be 24 inches. Individual tube bundles shall have provisions to facilitate repairs to the tube and header areas without cutting into adjacent tube bundles.

Bends, tees, elbows and downstream straight pipe sections in HRSG areas at high risk for flow accelerated corrosion (erosion-corrosion) shall be fabricated from material containing at least 2.25% chromium. HRSG design shall include proven features to prevent LP erosion/corrosion (due to flow acceleration) and shall be subject to Owner approval.

Ceramic insulation shall be used for all insulated portions of the HRSG (no mineral wool). The entire interior surface of the HRSG shall be lined, from the combustion turbine exhaust flange to the base of the exhaust stack, with steel liners, as follows:

Location	Temperature	Material	Thickness (BWG)
Walls	Up to 700°F	Carbon Steel	12 Ga.
Roof	Up to 700°F	Carbon Steel	12 Ga.
Floor	Up to 700°F	Carbon Steel	12 Ga.
Walls	701°F to 1200°F	TP 409 SS	16 Ga.
Roof	701°F to 1200°F	TP 409 SS	16 Ga.
Floor	701°F to 1200°F	TP 409 SS	12 Ga.
Walls	1201°F to 1400°F	TP 304 SS	16 Ga.
Roof	1201°F to 1400°F	TP 304 SS	16 Ga.

Floor	1201°F to 1400°F	TP 304 SS	12 Ga.
-------	------------------	-----------	--------

Non-steaming economizers shall be provided. Suitable recirculation piping loops shall be provided to maintain sufficient flow through the economizers to prevent steaming during startup of the HRSG. Feedwater and regulating valves shall be configured to provide reliable performance while operating at reduced flow.

The HRSG exhaust stack shall be of self-supporting, carbon steel construction designed and constructed in accordance with ASME/ANSI STS-1. Corten is not acceptable. The required exhaust stack top elevation shall be based on the output of the air permitting process. Exhaust gas sampling and other stack design provisions shall meet all EPA requirements and air permit requirements. The minimum stack gas temperatures and velocity shall meet all permit requirements over the full range of operation. Provide a davit for hoisting tools and test equipment. Provide 120V and 220V single-phase convenience outlets for power tools and test equipment at all stack platforms. Provide lightning protection to minimize potential for personnel injury, structural damage or equipment damage. Provide a minimum of one access door on lower stack breaching to facilitate access for maintenance and inspection. Each exhaust stack shall be provided with a motor operated damper. Provide stack P-trap drain to remove rainwater when stack is not in operation. Each stack shall be designed with a 1/8-inch corrosion allowance for the bottom ten feet of the stack and 1/16-inch thereafter, or be provided with a stainless steel liner.

Piping materials for the HRSG shall be manufacturer's standard, based on appropriate design codes and standards.

Drains shall be provided at various parts of the HRSG for complete water removal to facilitate maintenance. The drain system shall be designed to drain all water from the boiler to protect against freezing during periods of sustained outages and low ambient temperatures. All HRSG drain connections shall have two globe valves in series and the second root valve shall be located at grade level or at a location having permanent access. All drains shall be piped to either a condensate flash tank or a turbine drains tank. Casing drains shall be provided to continuously drain any condensation from exhaust gas. Vents shall be provided at accessible locations on the HRSG to allow air to enter to facilitate drainage prior to maintenance. Provisions shall be made for venting air during filling and startup. Provisions shall also be provided on the steam drums for nitrogen blanketing during extended shutdowns to minimize corrosion. The nitrogen connections shall be provided at grade. Vents used for plant startup shall be silenced to conform to plant noise permits.

Design HRSG steam side components to be fully drainable and include valved drains on each component accessible from outside the unit. Provide drain system sized such that any single pressure level, to include the drum, economizer, superheater, tubes, headers and piping, can be drained in a maximum of 8 hours.

Provide isokinetic steam sampling nozzles per ASTM standard D1066 for measuring steam purity.

HRSG shall be designed with pinch points no less than 13°F.

Design economizers such that steaming does not occur during normal operation. Steam venting will be allowed at part load conditions, provided provisions are included in the system for venting this steam to the corresponding steam drum. Venting shall be controlled with a motor operated vent valve

Pressure Drops:

1. Pressure drop for the HP drum to the HP superheater non-return valve shall not exceed 6% at maximum steam flow.
2. Pressure drop from the HRSG cold reheat inlet connection to the HRSG hot reheat outlet connection shall not exceed 4% at maximum steam flow.
3. Pressure drop from the IP drum to the IP superheater outlet connection shall not exceed 6% at maximum steam flow.
4. Pressure drop from the LP drum to the LP superheater outlet connection shall not exceed 6% at maximum steam flow.
5. Pressure drop from the HP economizer inlet to the HP drum shall not exceed 2% at maximum steam flow.
6. Pressure drop from the IP economizer to the IP drum shall not exceed 2% at maximum steam flow.
7. Pressure drop from the Feedwater Preheater to the LP drum shall not exceed 2% at maximum steam flow.

The attemperator shall be located and designed so that under the most adverse operating conditions the temperature of the steam leaving attemperator-mixing zone will exceed the saturation temperature by at least 25°F.

Provide structural and miscellaneous steel required to frame and support the steam generator and all component parts and equipment. Provide structural steel supports for flues, ductwork, transitions, casing and stack as required. The structural steel frame shall be designed to take all piping loads of those pipes connecting to the boiler, within the boiler frame area.

The transition duct angle shall not exceed a 45° angle between floor and roof of transition. Alternate proven configurations shall be subject to approval by Owner.

#### 5.2.8.4 Drums

Size steam drums to provide stable operation under all load conditions including start-up, shutdown, and load variations. Size high pressure and intermediate pressure steam drums to provide a minimum of three (3) minutes of storage with no incoming water at the fired steaming rates between the normal water level and Low Low Trip points. Contractor shall size low-pressure steam drum to provide a minimum of five (5) minutes of storage, with no incoming water, at the fired steaming rates, between the normal water level and Low Low Trip points. HRSG gas side expansion joints shall be of a flanged, insulated design.



Drums shall be fusion-welded throughout with all welds made, tested, radiographed and stress-relieved in strict accordance with the ASME Boiler and Pressure Vessel Code, and approved by a recognized boiler inspection and insurance company.

The steam-separating drum shall be equipped with the following internals:

1. A means to assure even distribution of feedwater throughout the drum length and equal distribution of flow to the downcomers.
2. Alloy steel chemical feed piping.
3. Steam and water sample piping.
4. Steam deflecting baffles.

Vane- or centrifugal-type steam-cleaning devices designed to ensure a minimum of pressure drop, to provide maximum free space in the drum, and to limit carryover of impurities into the superheater to the level required by the steam manufacturer and in accordance with ABMA guidelines.

All drum internals shall be fabricated in convenient lengths for removal from the drum through the manholes.

Each end of the steam-separating drum shall have a manhole not smaller than 12 in. by 16 in. with a machined seat and forged steel cover hinged to swing inward. Manholes shall be complete with gaskets, arbors, and bolts. Furnish one extra set of gaskets to be turned over to the Owner.

Nozzles shall be fusion-welded to the drum, and the welds shall be stress-relieved.

#### 5.2.8.5 Piping

All pressure parts of the boiler, superheater and economizer shall be connected together as necessary to meet the following requirements:

Provide piping and connect to the steam generator pressure parts:

1. Nitrogen blanketing connection (single connection unless multiple connections are required to blanket entire steam generator).

All necessary piping, valves, fittings, constant force piping supports, and insulation which, when combined with the above items, will constitute a complete steam generating unit. This shall include, but is not limited to, the following:

1. Piping from economizer outlet to steam drum.
2. Double shutoff valves at all external connections to the steam generator pressure parts, whether connected to by Owner or Contractor. The only exceptions to this requirement are the following connections:
  - A. Economizer Water inlet

3. Safety valve connections - Contractor shall furnish safety valves as required by ASME Boiler and Pressure Vessel Code. All safety valves shall be installed in piping furnished by this Contract.
4. Safety valve exhaust piping to a point 10 feet above the elevation of any platform within 25 feet.
5. All vent stacks to a point 10 feet above elevation of any platform within 25 feet.
6. All drain piping and the drum blowdown piping to a point two feet above grade elevation. Location of terminations shall be subject to Owner's approval.

Provide pipe supports for all piping furnished. Supports shall be designed to support the weight of all piping furnished by this Contract.

HRSGs shall be provided with provisions for sampling steam and boiler water, and provisions for blowdown and chemical injection to control dissolved solids in the HRSG operation. The HRSGs shall also be provided with the capability for chemical cleaning after construction.

Drains and vents shall be sized, with remotely operable valves, to allow for frequent starts and short start times and to prevent thermal quenching.

Each HRSG shall be controlled by the plant DCS and shall operate without local attendance. Visual monitoring of the drum levels shall be provided in the control room. The HRSG controls shall comply with all code requirements and shall operate to prevent injury to personnel and damage to the HRSG and other equipment, under all operating and abnormal conditions.

The maximum exhaust gas pressure drop at ISO conditions between the gas turbine discharge and the stack exit, including SCR and CO catalyst, shall be less than 17 inches of H<sub>2</sub>O.

Contractor shall provide minimum of 3 feet clear wide access platforms on the HRSG to facilitate access all around the steam drums and to all instrumentation and elevated manual valves on the HRSG system. Drum level support steel shall not include vertical bracing. Drum end enclosures shall be provided. Only the exhaust stack shall rise higher than 12 inches above the enclosure. Provide a minimum of one set of stairs to access all levels of the platforms and provide alternate egress as required by OSHA.

HRSGs and piping systems shall be designed to proportionally control the cold reheat steam flow to the high pressure steam flow to balance the cold reheat flows between multiple units at all operating conditions.

Contractor shall provide a recirculation system to maintain a minimum stack gas temperature above acid dewpoint under all operating conditions. The condensate temperature setpoint shall be selectable in the DCS.

Contractor shall provide flanged EPA test ports on the stack sized and located in accordance with the air permit requirements. Provide 5 feet minimum wide, full 360° access platforms with ladders to facilitate access to the sample ports. Provide FAA Aviation Lights as required for the stack.

Contractor shall insulate the steam drums and the entire casing of the HRSG through the low pressure economizer section to maintain an external surface temperature at or below 140°F at all operating conditions. The insulation thickness design will be based on an air velocity of 5 mph and an ambient air temperature of 100°F or OSHA requirements, whichever is lower. Provide ventilated and heated drum end enclosures or other suitable protective devices to prevent freezing of the drum trim piping when the HRSG is not in operation and the ambient temperature is at the absolute minimum for the site. The insulation shall be certified asbestos free by the manufacturer.

Contractor shall provide all specialty valves and instrumentation required by the applicable ASME code and including, but not limited to, the following for each HRSG:

1. Drum pressure safety valves with silencers on each steam drum
2. Superheater pressure safety valves with silencers on each superheater
3. Start-up vent valves with silencer and pneumatic operators on each pressure system
4. Automatic continuous blowdown regulating valves with operators on each evaporator system.
5. Intermittent blowdown stop valves with power operator on each evaporator system.
6. Continuous drum blowdown stop valve with power operator for each drum
7. Feedwater stop valves with power operators on each evaporator system
8. Drum level control valves with operators on each evaporator system
9. Superheater drain valves with power operators on each superheater section
10. Steam stop valves with power operators on each outgoing steam line
11. Steam stop-check valves on each outgoing steam line
12. Water column, with probe type alarms: HH, H, L, LL on each drum
13. Water gauge glass on end of each drum
14. Two remote drum level indicators for each drum (one located in control room and one located at the drum level control valve bypass station)
15. Three remote drum level transmitters on each drum
16. Drum pressure transmitters on each drum
17. Drum pressure Indicators on each drum
18. Drum pressure switch on each drum
19. Four drum surface thermocouples for each drum

20. Feedwater thermocouple with well on each drum feedwater line
21. Feedwater temperature indicator with well on each drum feedwater line
22. Feedwater pressure indicator on each drum feedwater line
23. Economizer inlet and outlet thermocouple with well for each economizer
24. Economizer inlet and outlet temperature indicator with well on each economizer.
25. Superheater steam outlet temperature indicator with well for each superheated steam discharge line
26. Superheater steam outlet thermocouple with well for each superheater steam discharge line (two on high pressure steam)
27. Superheater steam outlet pressure indicator for each superheated steam discharge line
28. Cold reheat thermocouple with well
29. Cold reheat pressure indicator
30. High pressure steam and reheat steam attemperators with control valves and actuators
31. Attemperator inlet and outlet thermocouple with well for each attemperator
32. Attemperator inlet and outlet temperature indicator with well for each attemperator
33. Recirculation pump inlet and outlet pressure indicator
34. Recirculation pump outlet thermocouple with well
35. Low pressure economizer inlet thermocouple with well
36. CTG exhaust gas temperature indicators with well (two at inlet transition and one after each component section)
37. CTG exhaust gas absolute pressure indicators (one at inlet transition and one after each component section)
38. Power operated vent and drain valves.
39. Instrument isolation valves, including root valves for all pressure gauges and transmitters.

#### 5.2.8.6 Ductwork, Casings and Insulation

Provide all equipment, materials and labor necessary to encase and insulate the steam generator unit.

Casings, transitions, and ductwork shall be internally insulated.

Outer casing shall be at least 3/16-inch and shall provide a gastight seal. All field joints in the outer casing shall be designed to be seal welded.

All casings, transitions, and ductwork shall be provided with external stiffeners and shall provide a gastight seal at 1.5 times the maximum operating pressure. Penetrations shall be sealed to prevent leakage.

Provide drain connection in bottom of casing to allow for water washing. Drain shall be 2-inch-minimum size, provided with a cap.

Inner casing liner shall be stainless steel. Design inner casing with adequate allowances for expansion, and to protect insulation from gas flow.

Provide gas distribution devices necessary to assure even distribution of gas across heat transfer surfaces.

Casing, insulating, and lining materials shall have been proven acceptable in units of comparable capacity, temperature, and pressure.

#### 5.2.8.7 Insulation

Insulation and other materials shall be in strict compliance with the applicable ASTM standard specifications. They shall be certified asbestos-free by the manufacturer.

Insulation shall be designed so that the outside surface temperature measured at any point (including hot spots) will not exceed 140°F when the ambient air temperature is 100°F 5 feet away from skin or insulation (while the steam generator is operating), with an outside surface air velocity of 5 mph. Insulation thicknesses shall be reviewed and approved by Owner.

1. Insulation shall be ceramic fiber suitable for design conditions conforming to ASTM C533 or Engineer-approved equal.
2. The binder used in the insulation shall show no deterioration at 100°F above the actual operating temperature where the material is applied. Binders shall be water repellent.
3. Minimum density of any blanket or block insulation shall be 7 pounds per cubic foot.

#### 5.2.8.8 Access

Provide Class 1 access to all areas requiring access during operation, or for normal day-to-day inspection and maintenance, including the following:

1. Observation ports.
2. Lubricated equipment.
3. Instruments.
4. Valve operators.

5. Each end of boiler drums.

Access doors shall be standard cast-hinged doors closed with a strong back arrangement. Provide ladder rung as a handhold above access doors, both on interior and exterior. Access doors shall be a minimum size of 14"x18".

Provide access lanes between each section of the steam generator.

Contractor shall provide expanded metal personnel protection shields or other suitable personnel protection devices at each stack access platform and anywhere else on the HRSG systems where temperatures exceed OSHA limits. Personnel protective devices shall be provided in accordance with applicable OSHA standards.

5.2.8.9 Duct Burners

Supplemental duct firing may be included in Contractor's design to maximize steam generation. At maximum duct burning each HRSGs shall be capable of supplying high-pressure superheated steam to the steam turbine at throttle pressures and temperatures as dictated by Contractor's design.

If included, duct burner design shall meet the following criteria:

1. The duct burners shall be a low-NO<sub>x</sub> design that meets the requirements of the project air permits over the full range of plant operating loads and ambient conditions.
2. Superheated steam temperature spread across the HRSG shall not exceed 70°F at any point. Distance from duct burner to first row of tube bundles shall not be less than 15 feet.
3. Tube metal temperature shall not exceed the limits specified by the HRSG manufacturer at any operating condition (fired or unfired). Instrumentation shall be provided for monitoring tube skin temperature and flue gas temperature downstream of the duct burner. Skin temperatures shall be measured throughout the HRSG cross-section, including tube sections located outside of the HRSG casing. Flue gas measurement taps shall be provided at every 10 feet (vertically) from the bottom of the HRSG casing, approximately 3 feet in from the sides of the casing on both sides of the HRSG.
4. Provide a minimum of two view ports per burner (one on each side) in HRSG casings to allow viewing the duct burner flames.
5. Duct burner runner controls, scanners, and view ports shall be accessible from the platforms without requiring ladders or scaffolding.
6. Duct burners shall not utilize air augmentation.
7. The minimum oxygen level in the duct burner exhaust gases shall not be less than those specified by the burner manufacturer.
8. The duct burner control system shall be fully integrated with the plant DCS.
9. The duct burner shall provide a stable flame over a 10 to 1 automatic turndown range.

10. Provide automatic isolation valve for each burner runner (elevation).
11. Duct burner flame scanners, pilot burners, and pilot igniters shall be provided. Include two 100% scanner cooling / purge air blowers each with an inlet air filter and silencer. Two flame Scanners shall be supplied per each burner.
12. Include a Burner Management System (BMS) with a programmable logic controller, factory assembled, wired, and tested, including all safety interlocks and indicators as required by the applicable codes. Provide BMS system designed for remote firing rate signals to be supplied from the main plant DCS controller. The PLC shall be in an air-conditioned enclosure.
13. The fuel gas manifold in the turbine exhaust gas flow shall be type 304 stainless steel.
14. Provide a strainer and a PRV for conditioning of fuel gas supply to the burners. PRV shall be located at grade or platform accessible.
15. Duct burner shall be located in a cross-section of the ductwork and the duct burner shall distribute fuel gas evenly across the duct.
16. Duct burner shall be located to prevent impingement of flames on the tube surfaces.
17. Burner elements shall be designed to allow for thermal expansion and to prevent acoustic vibration.
18. If multiple burner elements are required, provide distribution headers for fuel gas, igniter gas, and scanner cooling air.
19. Duct burner frame shall be insulated for protection from flue gas temperatures.
20. Burner ignition shall be completely automatic.
21. Ignition system shall include gas pilot burner, electric ignition electrode, electric ignition transformer, two power-operated shutoff valves, one manual shutoff valve, pilot gas regulator and strainer.

The duct burner installation shall meet all requirements of NEC, NFPA, Factory Mutual, and local codes.

#### 5.2.8.10 Selective Catalytic Reduction System

A selective catalytic reduction (SCR) system shall be incorporated into each HRSG to meet the NO<sub>x</sub> and ammonia slip emission limits specified in the air permit over the full range of operation from Peak Load to Minimum Load and the full range of ambient temperatures. The SCR system design and location shall include consideration of operating temperature requirements for proper catalyst performance, flow straightening devices, ammonia injection grids, and mixing zones. SCR shall be capable of responding in real time to allow for load level changes, up to maximum ramp rate, up or down, so as to maintain permit limits for hourly averages.

SCR system casing shall be of the same construction and cross section as the HRSG casing. Provide access manways and catalyst loading openings in the casing sufficient

to facilitate removal and installation of the catalyst modules without the need for cutting or welding of any casing components. Include and integrate a monorail and hoist system to facilitate installation and removal of the catalyst sections. Hoist system shall extend out over open grade for lifting and setting materials from maintenance carts of pallets.

Include space, frame, and design consideration for 50% additional catalyst in the SCR system.

Provide instrumentation necessary to monitor catalyst performance. Provide NO<sub>x</sub> sample ports upstream of the SCR Catalyst.

Contractor shall obtain from SCR catalyst Vendor a warranty that the installed catalysts will provide NO<sub>x</sub> emissions reduction from the guaranteed combustion turbine emissions, including contribution from the duct burners (if provided), down to the permitted HRSG stack emissions for a minimum period of thirty-six (36) months after the plant Substantial Completion Date, or 22,500 fired hours of operation, whichever comes last.

Testing penetrations consisting of 2 ½ inch pipe connections shall be provided to permit performance testing of the system. The test ports shall have blind flanges. The design and configuration of the test ports shall allow traverse testing before and after each layer of catalyst in a grid arrangement. Contractor shall provide access to the test locations consisting of walkways, platforms and ladders.

The SCR catalyst shall be of the low dust type. The catalyst shall be designed to minimize pressure loss. The direction of gas flow through the catalyst shall be horizontal.

The catalyst shall be either a homogenous extruded material or the catalyst surface shall be supported on a metallic or ceramic monolithic base material. The catalyst modules shall not be subject to delamination or permanent deformation of the catalyst or support material due to stresses induced by the seismic conditions, vibration, pressure and thermal conditions or combinations thereof.

The catalyst shall be resistant to poisoning by trace elements. The catalyst shall be resistant to water and abrasion.

The volume of catalyst supplied shall be designed to control ammonia slip to the values guaranteed without requiring cleaning, regeneration, or replacement during the performance guarantee period.

The catalyst shall be of modular design to facilitate installation and removal of the catalyst. The catalyst modules shall be the maximum practical size to facilitate and minimize field maintenance. Any special tools required to facilitate the removal or installation of catalyst modules shall be provided. Any special tools or handling fixtures for the proper handling or unloading of the catalyst modules from a truck or rail car shall be provided.

Contractor shall provide catalyst coupons/holders. In order to monitor catalyst life and performance, a minimum of 10 test coupons shall be provided and installed in the catalyst beds as, and where, recommended by the catalyst manufacturer. Additional



catalyst coupons shall also be furnished for future reference performance and composition analysis. Each catalyst coupon shall be labeled with a serial number. All catalyst coupons shall be from the same lot as the installed catalyst. These samples will be tested to evaluate catalyst activity and physical properties as the catalyst ages.

The catalyst modules shall include sealing frame and frame steel to improve the ease of catalyst replacement and installation. The frame materials shall be compatible with the catalyst material. The sealing system shall be designed to limit exhaust gas leakage past each layer of catalyst. The sealing mechanism and materials shall provide a service life equal to or greater than the catalyst.

#### 5.2.8.11 Ammonia Injection Skid

Contractor shall provide a skid mounted aqueous ammonia (19%) injection system complete with all necessary equipment, including but not limited to mixers, blowers, motors, electric or side stream heaters, piping, all valves, vent and drain piping and instrumentation. Two (2) 100% capacity flue gas recirculation air blowers shall be provided as well as associated valves, control valves, and NH<sub>3</sub>/air mixer for each skid. The critical components including, but not limited to, the dilution air fans and the electric heaters shall have an installed 100% spare on the skid. The heaters and blowers shall be designed for 100% of maximum flow of reagent to the ammonia injection grid.

#### 5.2.8.12 CO Catalyst

Provide a CO catalyst system with each HRSG to meet the air emission requirements for CO and VOCs. The CO catalyst shall be designed and located in the HRSG to meet the requirements of the air permit over the full range of operation from Peak Load to Minimum Load and the full range of design ambient temperature.

Include space and consideration for 50% additional CO catalyst.

CO catalyst system casing shall be of the same construction and cross section as the HRSG casing. Provide access manways and catalyst loading openings in the casing sufficient to facilitate removal and installation of the catalyst modules without the need for cutting or welding of any casing components. Include and integrate a monorail and hoist system to facilitate installation and removal of the CO catalyst sections. Hoist system shall extend out over open grade for lifting and setting materials from maintenance carts of pallets.

Provide instrumentation necessary to monitor catalyst performance. Contractor shall obtain from the CO catalyst Vendor a warranty that the installed catalysts will provide CO and VOCs emissions reduction from the guaranteed combustion turbine emissions, including contribution from the duct burners, down to the permitted HRSG stack emissions for a minimum of thirty-six (36) months after the plant Substantial Completion Date.

#### 5.2.8.13 HRSG Erection

Work shall include the following:

1. All expert and common labor, rigging, blocking, scaffolding, tools, construction materials and supplies to remove the Equipment from cars, haul, store, protect, erect, and install all the material furnished complete in place.
2. Grout and grouting, shims, grout forms, and blocking.
3. Erection of structural and miscellaneous steel.
4. Erection bracing, temporary struts, ties, cables, temporary flooring, planking, and scaffolding as required for the erection of the unit.
5. Furnishing and installation of miscellaneous pipe hangers and supports for piping installed with the Equipment. Installation of nipples, valves, and safety valves.
6. Welding of piping supplied with the Equipment by manufacturer's procedures acceptable to Owner, including testing of welds where required by codes and all costs in connection with welder qualification tests.
7. Installation of trim, instruments, control devices, start-up thermocouples, and bearing thermocouples furnished as specified.
8. Installation of setting, insulation, and lagging, including supplying all materials as required for a complete installation.
9. Cleaning up, testing and placing into operation the Equipment, including attendance by manufacturer's service representatives during preliminary operation, testing, boilout, blowout, and cleaning as required to make necessary adjustments and perform work to make unit acceptable.
10. Inventorying and turning all spare parts over to Owner.
11. Inventorying and delivering all special tools and devices furnished as part of the Equipment to Owner in good condition after erection is completed.
12. Testing, adjusting boiler trim, including setting of safety valves under direction of valve manufacturer's representative.
13. Attendance for Owner's insurance inspector, including opening unit for inspection and as required.
14. Boiling out the unit.
15. Chemically cleaning the unit.
16. Steam line blowing.
17. Retouching of damage to shop prime and finished painted surfaces.
18. Protection of steam generator from freezing, including maintenance of temporary heating equipment.
19. Alignment of Equipment for smooth, trouble-free operation.

20. Preparation of Equipment and piping ready for external connections at terminal points.
21. Acceptance testing as specified.
22. Retightening flanges, valve bonnets, and repacking leaking valves.
23. Calibration of instruments and tuning of controls.
24. Disconnecting and reconnecting couplings for motor rotation check.

The installation of the Equipment shall be complete in all respects, to make the unit ready for commercial operation except for Owner's connections under other contracts. Provide Owner with copies of all data reports required by the ASME Boiler and Pressure Vessel Code and ANSI B31.1.

FIELD SUPERVISORS:

1. The services of erection supervisors shall be furnished to supervise and be responsible for the complete and correct erection, assembly, and installation of the Equipment furnished under this Contract.
2. Supervisors shall report to the jobsite prior to the commencement of erection to plan and coordinate the Work, and be present during unloading, storing, hauling, erecting of all Equipment, and at such other times that his services are required as determined by Owner.
3. Supervisors shall keep Owner informed on the progress of the Work during erection and testing and coordinate work with Owner on any problems that will affect progress of the Project.

MANUFACTURER'S FIELD SERVICE:

1. Contractor shall include in the Bid the cost of the services of competent manufacturer's servicemen for field testing and placing in operation all electrical devices and safety valves for inspecting and placing in operation control systems provided.

GROUTING:

1. Furnish and place all grout required to erect and install the Equipment and machinery.
2. Except where otherwise specified by the Equipment manufacturer, grout all equipment and machinery with a nonshrinking grout.

3. Prepare and place grout in accordance with the manufacturer's written instructions.
4. Furnish and install grout forms. Grout forms shall be tight and shall be caulked as required to prevent leakage.
5. Chip back and clean foundation surfaces as required for proper clearances and to obtain proper bonding.
6. Grout bed shall have at least 2 inches of thickness for every four feet of horizontal grout flow required, and shall be as required to properly align and position the Equipment and machinery in accordance with the Equipment manufacturer's requirements.
7. Protect anchor bolt sleeves from freezing using methods approved by Engineer. This requirement shall be Contractor's responsibility from the date the foundation is released to Contractor for his use until grout has been placed to prevent water from entering the sleeves.
8. Grout all anchor bolt sleeves, unless otherwise specified by the Equipment manufacturer.
9. Place grout under entire base plates, support plates, and bed plates. Drill grout vent holes if necessary.
10. Protect grout for at least 24 hours against rapid water loss. Maintain grout between 65°F and 80°F until cured. After grout has hardened for at least six hours, remove grout forms, remove excess grout to a neat trim line, and apply a coat of an approved curing compound. Care shall be taken to prevent the transmission of vibration from operating machinery and construction activities to the Equipment being grouted.
11. Unless otherwise directed by Equipment manufacturer's instructions, grout leveling and support shims and wedges in place with nonshrink grout. The shims and wedges shall be completely encased in grout.

WELDING:

1. Perform all welding as required for the installation of the structure, Equipment, and piping.
2. Welding rod shall be the best quality rod, suitably shielded, designed and made for use with the specific material to which it is applied, and shall conform to the

latest ASME specifications or AWS D1.1. Rod used on alloy materials shall be ordered by ASME or AWS specification and chemical composition.

3. Provide welding rod drying ovens when required. The use of wet or moist welding rod will not be permitted.
4. Welding procedures shall be in accordance with the ASME Boiler and Pressure Vessel Code and the applicable portions of ASME B31.1. Structural steel welding shall be in accordance with AWS D1.1 and the AISC specifications.
5. All welders and welding operators shall be qualified as required by the applicable codes. Submit three copies of qualification test records for each welder and welding operator. All costs for welders' qualification tests and certification shall be at Contractor's expense.
6. Heat treat welded joints in accordance with the ASME Boiler and Pressure Vessel Code and the applicable portions of ANSI B31.1.
7. All welds shall be inspected by the designated agencies as required by the various codes including radiography of welds where required by code. All costs for the required inspections and radiography shall be at Contractor's expense.
8. All welding shall be in accordance with the best modern practices to reduce distortion to minimum. Include tack welds and alignment clips, as required.
9. For P-91 and T-91 materials, Contractor shall submit special welding procedures and NDE to be used to avoid weld joint failures in the field and during normal operation.

ERECTION AND INSTALLATION OF PRESSURE PARTS AND PIPING:

1. Erect and install all pressure parts and piping in accordance with the applicable portions of the ASME Boiler and Pressure Vessel Code and ASME B31.1.
2. Erect pressure parts and piping true to line, facing, and position and without strain on pipe, fittings, and Equipment.
3. Make final weld in piping systems only after stress relieving all other welds, and after obtaining correct alignment.
4. Keep foreign matter out of tubes, drum, piping, and other pressure parts. Clean, blow out and sound all pressure parts to assure they are clear and clean.
5. Connections to rotating Equipment shall be disconnected as required for alignment checks. Correct any misalignment of the piping.
6. Erect and install hangers and supports as follows:

- A. Install hangers, supports, and anchors as required to adequately support the pressure parts and piping.
- B. Adjust hangers as follows:
  - (1) Prior to putting the Equipment and piping systems into service, remove travel stops, adjust all spring hangers to the correct cold load, adjust all solid hangers to correct position, and remove all temporary hangers used in erection and testing.
  - (2) After and during the time the Equipment and piping systems are being put into service, adjust all spring hangers for the correct hot load and align all hanger rods to the vertical position. Furnish and install additional hangers, sway braces, and bracing as required to stabilize piping systems.
- C. Field fabricate piping as follows:
  - (1) Field fabricate and erect piping for miscellaneous systems and small pipelines.
  - (2) Field route small piping to avoid interference with other work and to provide a neat installation. Reroute and arrange as directed and as approved by the Engineer. Erect with off sets, fittings, unions, drip pockets, vents, drains, and hangers to make a complete installation.
- D. Retighten flanged joints as follows:
  - (1) Retighten flanged joints in pipelines and on Equipment after being exposed to working temperature and pressure for a sufficient length of time to ensure that flanges and studs have reached a point of constant temperature, and have attained such changes in dimension as will take place.
  - (2) Where the operating temperature is 450°F or higher, retighten joints after 200 hours of service at operating pressure and temperature.
  - (3) Tighten pressure seal valve bonnet studs or spanner nut with torque wrench per manufacturer's instructions before start-up and after one temperature cycle.
- E. Make up flanged and threaded joints as follows:
  - (1) Apply gaskets for low-pressure, low-temperature joints dry. Apply all other gaskets in accordance with the gasket manufacturer's instructions.

- (2) Use an anti-sieze compound to lubricate all flange bolt and stud-bolt threads and all threaded pipe joints, with the compound applied to male threads only. Antisieze compound shall be suitable for temperatures up to 1,000°F and shall be "Molykote G" or approved equal.
- F. Furnish and install unions in piping systems using screwed joints as follows:
- (1) Install in pipelines so lines may be broken for maintenance, valves may be removed and Equipment disconnected.
  - (2) Install in lines which are erected without unions and which, in the opinion of Engineer, cannot be properly maintained.
  - (3) Install dielectric unions wherever copper pipe is joined to iron or steel pipe or equipment. Install in positions which receive axial thrust only.

INSTALLATION AND APPLICATION OF BRICKWORK, REFRACTORY, INSULATION AND LAGGING:

1. Provide fire-resistant drop cloths and enforce their use to keep refractory and insulating materials off gratings, floors, structures, and Equipment not specified to be insulated.
2. Do not apply brickwork, refractory, insulation, and lagging over welded joints until Equipment has been hydrostatically tested.
3. Install and apply brickwork and refractory as follows:
  - A. Install clips or studs on Equipment as required to properly support and attach brickwork and refractory.
  - B. Thoroughly clean surfaces prior to installing brickwork and refractory to ensure secure bonding. Sandblast corroded surfaces where required.
  - C. Brickwork shall be installed complete with mortar and grout to form a continuous surface free of cracks and voids. Saw cut into special shapes where required to fit irregular areas. Grout and mortar mixtures shall be in strict accordance with the manufacturer's recommendations and instructions.
  - D. Refractory mixture and application shall be in strict accordance with manufacturer's recommendations and instructions. Furnish all equipment required to apply refractory.
4. Apply insulation and lagging as follows:
  - A. Install insulation pins, clips, and studs on Equipment as required to properly support and attach insulation.

- B. Store all insulating and lagging materials indoors. Protect materials from damage due to moisture, crimping, buckling, spotting, streaking, and similar causes.
- C. Provide weather protection for all insulation materials during and after application until such time as the insulation is lagged and enclosed to form final weather protection.
- D. Install all insulating materials in strict accordance with the manufacturer's recommendations, specifications and instructions, and as specified. Completely cover all surfaces to be insulated so there are no voids, cracks, or depressions. Adequately support insulating materials with wire mesh, expanded metal lath, and tie wires so that insulation will not shift, sag, or separate.
- E. Provide laps, seals and flashing to make lagging weathertight. Seal all penetrations through lagging weathertight. Install lagging so ribs form a smooth unbroken line and so that water is not pocketed in the ribs.

EQUIPMENT AND MACHINERY ERECTION:

- 1. Erect and install all Equipment and machinery in strict accordance with manufacturer's instructions and as directed by the manufacturer's field representatives.
- 2. Meet the requirements of the manufacturer and/or his field representative for the means employed for doing the various classes of work, all tolerances in alignment and leveling, and the quality of workmanship for each class and stage of the Work.
- 3. Protect all Equipment, machinery and Materials against corrosion, moisture deterioration, mechanical injury, and accumulation of dirt or other foreign matter to include the following:
  - A. Protect all bearings by field lubrication as required.
  - B. Keep all pipe and equipment connections closed until ready for connection.
  - C. Cover Equipment, machinery, and Materials with suitable covers and provide temporary heat where required.
  - D. Spot paint all Equipment and machinery where the shop coat of paint has been damaged.



4. Provide access to motors in storage for the power wiring contractor to connect temporary power to the space heaters and to megger the windings.
5. Cover and protect Owner's concrete and floor surfaces from scarring and oil spots.
6. Furnish and install cinch anchors, grout, shim material, and the miscellaneous steel necessary for brackets, anchors, or supports required in the installation of the Equipment and machinery.
7. Replace any gaskets damaged during storage, inspection, cleaning, or placing into service.
8. Accomplish all field machining that might be required to fit Equipment and machinery together or to install Equipment and machinery.
9. Align Equipment as follows:
  - A. Make all measurements and determine elevations to position and align Equipment and machinery in accordance with the manufacturer's requirements.
  - B. Shim equipment, machinery, and motors as required to align Equipment and machinery at normal operating temperatures.
  - C. Align motors to Equipment and machinery with motor rotor at the mechanical center.
  - D. Tighten anchor bolts to proper stress level using torque wrench or by the turn-of-nut method.
  - E. Following initial alignment, pull and store coupling bolts, remove all shipping restraints, make all required inspections and checks, and tag motor as ready for rotational checks. Rotational checks will be performed by Contractor and witnessed by Owner.
  - F. After all connections are made and the Equipment and machinery is prepared for initial operation, set clearances as required and verify alignment. Have final alignment check and makeup of couplings observed by Owner.
  - G. Dowel motors to base plates after hot run in.
10. Lubricate Equipment as follows:
  - A. Prior to initial operation of the Equipment, clean and flush bearings and lubricating oil systems until clean. Circulate oil, vibrate lines, clean strainers, and replace filters in accordance with manufacturer's instructions. Drain

systems, wipe out reservoirs, and clean as required. Contractor shall furnish all flushing oils.

- B. After flushing fill all lubricating systems with oil and lubricate all Equipment with oil and lubricants provided by Contractor. Contractor shall provide a lubricant list for all Equipment using lubricants from Owner's supplier.

#### ERECTION OF FLUES, DUCTS AND PLATE WORK:

1. Furnish all erection bolts, clips, angles, and lugs required to align and position sections for welding.
2. Accurately align and position sections for welding and perform all welding in a manner to prevent warping and distortion.
3. Accurately align damper frames and install dampers without distortion. Adjust dampers for free operation and tight shutoff.

#### FIELD TESTS:

All field tests recommended by the manufacturers of the various items of Equipment shall be made by Contractor. Contractor shall provide all temporary testing equipment required.

1. Hydrostatic Tests:
  - A. After erection, all pressure parts and piping systems shall be given a hydrostatic test at a pressure 50% in excess of the design working pressure in accordance with the ASME Boiler and Pressure Vessel Code and the applicable portions of ASME B31.1.
  - B. Contractor shall provide cold water for the tests and suitable disposal facilities for wastewater after tests are complete. Contractor shall provide all piping, hoses, and drain lines to deliver water for testing and for disposal of water after testing. Water for hydrostatic testing shall be heated to a minimum temperature of 70°F. Contractor shall provide heat exchangers, chemicals, circulating pumps, and all piping required to heat and treat cold water to the proper temperature and quality.
  - C. Furnish all necessary equipment and materials required for testing including pumps, gauges, temporary blank-off plates, gaskets, anchors, and bracing required to conduct tests.
  - D. Furnish and install an accurate pressure recorder and continuously record the pressure during the complete hydrostatic test.

- E. Immediately repair or replace all tested Material or Equipment found leaking or defective.
  - F. Protect plant equipment and materials from damage resulting from leaks during testing. Protect instruments and appurtenances as required during testing and repair or replace if damaged. Clean fluid from leaks immediately after contact.
  - G. Provide all required attendance for Owner's insurance inspector, including opening the unit for inspection.
2. Boilout:
- A. On completion of erection, inspect, and mechanically clean the unit. Inspect drums, headers, supply pipes, and tubes and remove all debris. Blow out and sound all parts which cannot be visually inspected.
  - B. Boilout the unit with chemicals furnished by Contractor. Provide heat source necessary to heat water to proper temperature. Provide all piping, hoses, and drain lines required to deliver water and chemicals to the unit for boilout and for disposal of wastes after boilout.
  - C. After boilout, open the unit, wash down, and inspect. Replace gaskets, gauge glasses, and other parts damaged by boilout with new material provided by this Contract.
3. Instrument Calibration:
- A. Provide instrument technician to field calibrate all instruments furnished by this Contract.
  - B. Provide instrument technician to check and tune all control loops furnished by this Contract, including checking valve action.
4. Setting Safety Valves:
- A. Set all safety valves under the direction of the safety valve manufacturer's service personnel. Provide service personnel from the safety valve manufacturer under this Contract.
  - B. Provide all labor and attendance as required for setting all safety valves.
  - C. Schedule and coordinate the setting of safety valves with other contractors' work and the overall Project schedule. The superheater safety valves cannot be set until the blowing of steam lines is completed.
  - D. Operated drain valves as required to remove condensate from the main steam lines while setting the superheater safety valves.

5. Chemical Cleaning:
  - A. Provide the services of specialists in chemical cleaning of boilers to chemically clean the water sides of the unit. Chemical cleaning shall utilize citric acid followed by passivation.
  - B. Provide all labor, chemicals, compressed nitrogen gas, piping, valves, hoses, lances, pumps, and heaters required to supply and monitor cleaning solutions.
  - C. Provide all labor, pumps, piping, valves, and hoses required for disposal of wastes offsite. Contractor shall be responsible for locating disposal site off Owner's property and transporting wastes to a disposal site.
  - D. Provide all labor and attendance on a round-the-clock basis, if required, during the chemical cleaning operations.
  - E. Flush complete unit after chemical cleaning to include all tubes, headers, and downcomers. Provide all piping, hoses, and lances required for flushing. Contractor shall dispose of wastewater resulting from flush.
  - F. Remove, replace and seal weld hand holes, access openings, and pipe connections as required for chemical cleaning and flushing operations.
  - G. Wherever practical, parts subject to damage during acid cleaning shall not be installed until acid cleaning is completed. Replace any parts damaged by acid cleaning.
6. Conduct complete testing of combustion control system and burner safeguard system, including the following tests:
  - A. Out-of-case bench testing of all protective relays in accordance with relay manufacturer's instructions for testing. This testing includes such tests as checking of relay timing, restraint, calibration, and contact operation.
  - B. In-case testing of all protective relaying systems before energization to assure that relays trip (and lockout, if required) the proper breakers or devices. These tests shall include operation of relay contacts electrically or manually and checking breaker or device operation, and shall include introducing currents and potentials at their source and observing relay operation.
  - C. Conduct all field tests in the presence of Owner.
  - D. Provide all labor and test equipment required for field testing.

PLACING EQUIPMENT IN OPERATION:

1. Prepare unit for initial operation by testing, flushing and making operational checks as required to prepare all equipment and systems for operation at times required to meet the Owner's schedule for the initial operation of the complete steam generator unit.
2. Provide the services of competent start-up service personnel during the start-up and initial operation of the unit to perform the following:
  - A. Direct the starting operation of all equipment furnished.
  - B. Direct the operation of the equipment until it is placed into successful operation and is ready for commercial operation.
  - C. Coordinate starting, stopping and loading of unit with Owner's existing steam, electric and natural gas utilities.
  - D. Instruct the Owner's personnel in the operation, care and maintenance of the equipment.
  - E. Consult with manufacturer's field service personnel and providing them assistance as required to conduct the necessary tests and make any required adjustments.
  - F. Observe initial operation and direct Contractor's personnel to make adjustments as required for proper operation of the unit and its accessories and appurtenances.
  - G. Provide detailed written instructions for proper operation of unit, if such detailed instructions are not contained in the Instruction Books.
3. Procedures and work performed shall be as directed by the manufacturer's published procedures and service representative's instructions.
4. Repack valves, clean strainers, make repairs, and make adjustments as required until complete unit and all auxiliaries and appurtenances are in continuous successful operation.

5.2.8.14 Ammonia Equipment

Contractor shall provide one (1) aqueous ammonia (19% solution) storage tank with a minimum design pressure as required by Contractor's design. Tank shall be sized to contain two weeks worth of ammonia under 100% base load conditions. Provide a containment dike for the area surrounding the tank consistent with ANSI K61.1 guidelines. Ammonia system shall be in accordance with ANSI K61.1 and OSHA standards.

Provide an ammonia unloading skid with break away truck connections and with automatic emergency shut-off valves on the liquid and vapor connections on tank. Provide all instrumentation required by ANSI K61.1 and as required to provide for a safe, unmanned operation. Provide one (1) level transmitter and two (2) pressure transmitters on tank for remote monitoring and control. Provide accessible, local tank level indication. Provide ammonia leak detection system complete with local audible alarms and remote alarming to DCS.

Provide a platform and ladder to access all the manual valves and excess flow valves at the top of the tank and to maintain the relief valves and other instrumentation installed at the top of tank.

### **5.2.9 Blowdown System**

One blowdown tank including piping and valves shall be provided for each HRSG to receive blowdown and water/steam drains.

The blowdown system shall be designed to receive blowdown during all modes of operation including startup and continuous operation. Both intermittent and continuous blowdown shall be provided to control the solids, which collect in the drums. The continuous blowdown connection shall be located just below the low water level in the high pressure and intermediate pressure steam drums.

The continuous blowdown from the HP drum shall be directed to the IP drum. IP drum continuous blowdown shall be directed to the blowdown tank. High-energy blowdown (HP and IP) and low energy blowdown (LP) shall be separately connected to the blowdown tank. The valves and orifices used to control the blowdown flow shall be located as close as possible to the blowdown tank to minimize flashing and high velocity two-phase flow in the piping. The blowdown shall enter the tank through a thermal sleeve and steam sparger. The flashed steam shall be vented off the top of the tank while the liquid is cooled and discharged out the side near the bottom. The liquid blowdown shall be quenched and recovered to the cooling tower basin. Intermittent blowdown shall be taken from the mud drums of each evaporator section. Intermittent blowdown shall be directed into a separate tank inlet header of similar construction to the continuous blowdown header.

In addition to the boiler blowdowns, the blowdown tank shall be designed to receive water/steam drains from the high-pressure, intermediate pressure and low-pressure economizers, steam piping condensate drains, drum gauge glasses, and water column blowdowns.

The continuous blowdown shall be sized for a maximum blowdown rate of 3 percent of condensate flow to the HRSG.

Contractor shall provide expanded metal personnel protection shields or other suitable personnel protection devices at each blowdown tank where temperatures exceed OSHA limits.

The design of the blowdown piping shall be in accordance with the criteria established by the ASME Boiler and Pressure Vessel Code Section I, with minimal pressure drop to

the HRSG flash tank. The size of the HRSG blowdown and drain piping shall not be less than the size of the connections provided by the HRSG manufacturer.

### **5.2.10 Steam Systems**

The steam system shall be based on a three-pressure reheat cycle. The steam system shall be designed to provide HP, IP, and LP steam from the HRSGs to the steam turbine generator as shown on the Conceptual Process Flow Diagram in Appendix D.

Pressure relief valves, with silencers, shall be provided on the HP, reheat and low pressure steam headers to meet code requirements for overpressure protection. Upon steam turbine trip the primary release of steam shall be to the condenser through the steam bypass system. The secondary release shall be through the start-up vent valves to the atmosphere. Locate the start-up vent valves close to the HRSG isolation valves and size the valves and select the set points of these valves sufficiently below the steam drum relief valve setting to prevent lifting of the steam drum relief valves during overpressure transients.

The steam systems shall be provided with a high-pressure drain system to remove condensate from stop and control valves and piping low points to prevent water induction into the steam turbine. Drains that require quick action during startup shall be supplied with air operated severe service, metal seated ball valves. Drains not requiring quick action but required for steam piping drains shall be supplied with actuated valves or traps. All high-pressure drains shall be discharged to the condenser or to the blowdown tanks. All manual drains shall be piped to a drain header system that discharges to the either the condenser, or the blowdown tanks. Final steam drain pipe routings to be Owner approved. Steam piping shall be pitched in the direction of steam flow. All motor operated valves, air operated valves, and steam traps shall be provided with a block valve on each side. Steam traps shall be provided with a valved bypass.

The design and construction for the drain system shall comply with the latest ANSI / ASME TDP-1, Recommended Practices for the Prevention of Water Damage to Steam Turbines.

The maximum pressure drop between the HRSG and the steam turbine generator interface shall be 5% of the upstream line pressure for the HP steam line, 4.5% for the combined Hot and Cold Reheat steam lines, and 10% for the LP steam line. This maximum allowable pressure drop includes pressure drop across the piping, valves and all other components in the piping.

All steam piping shall meet the requirement of ANSI B31.1 and the ASME Boiler and Pressure Vessel Code, where applicable.

#### **5.2.10.1 HP (Main) Steam System**

HP steam shall be piped from each HRSG HP superheater outlet to the steam turbine. Each HRSG supply header shall be provided with a non-return stop check valve and a motor operated stop valve. A dedicated HP steam turbine bypass system to the cold reheat system shall be provided on each HRSG HP header for operating flexibility. HP steam bypass system shall be provided with combination pressure reducing and desuperheating valve or separate pressure reducing valve and desuperheater. The bypass piping shall be high temperature alloy pipe up to the downstream desuperheating

temperature measurement. The bypass system shall be sized for the maximum HRSG HP steam output without duct firing and shall be designed for continuous operation. A start-up vent valve shall be provided on each HRSG HP steam header. The start-up vent shall be sized to handle the difference in the HP steam flow between the maximum fired and unfired operation mode of the HRSG. The automated HP steam vent/dump control valve shall have equal percentage trim and a fast acting pneumatic actuator. Each HRSG HP superheated steam line shall also be provided with a low-pressure drop type flow element and transmitter for measuring steam flow.

#### 5.2.10.2 Reheat Steam System

Cold reheat steam from the HP steam turbine exhaust shall be piped from the steam turbine to the individual HRSGs. The cold reheat lines to each HRSG shall be provided with a modulating valve to proportion the cold reheat flows between the HRSGs and isolate the HRSGs from the common line. IP steam from each HRSG shall be combined with the HRSG cold reheat steam return from the turbine and piped to each HRSG reheater section. The IP superheated steam line shall be provided with a non-return valve, backpressure control valve, and motor operated stop valve prior to connection to the cold reheat line for isolating the HRSG IP drum. Each HRSG IP superheated steam line shall also be provided with a low-pressure drop type flow element and transmitter for measuring steam flow.

The hot reheat steam shall be piped from each HRSG to a common header feeding the steam turbine. Each HRSG hot reheat line shall be provided with a dedicated steam turbine bypass system consisting of a combination pressure reducing, desuperheating valve or separate pressure reducing valve and desuperheater for operating flexibility. Each reheat bypass line shall be routed to the steam surface condenser and provided with a diffuser on the condenser inlet. The bypass system shall be sized for the maximum HRSG output without duct burning and shall be designed for continuous operation. The bypass system shall be capable of handling a base load trip of the steam turbine by bypassing steam to the condenser without lifting the safety valves or the atmospheric vent valves. During this event, the bypass system shall maintain HRSG pressures at the level prior to the trip.

A hot reheat startup vent to the atmosphere shall be provided on each HRSG hot reheat steam line to facilitate unit startup. The start-up vent shall be sized to accommodate 100% of the unfired steam flow generated during drum soak. The automated hot reheat steam vent/dump control valve shall have equal percentage trim and a fast acting pneumatic actuator. Provide a motor operated stop valve on the hot reheat line from each HRSG.

#### 5.2.10.3 LP Steam System

LP steam from each HRSG shall be piped through a common header to the steam turbine and admitted to the LP steam turbine section. Each HRSG LP steam line shall be provided with a non-return valve and motor operated stop valve prior to connection to the common header. The LP steam system shall be designed to bypass the entire steam flow to the steam surface condenser during startup, shutdown, steam turbine trip, sudden load changes and when the steam turbine is out of service. The bypass system shall be sized for the maximum HRSG output without duct firing, shall include a diffuser inlet on the condenser, and shall be designed for continuous operation. The bypass system shall be capable of handling a base load trip of the steam turbine by bypassing



steam to the condenser without lifting the safety valves or the atmospheric vent valves. During this event, the bypass system shall maintain HRSG pressures at the level prior to the trip. An LP steam startup vent to the atmosphere shall be provided on each HRSG LP steam line to facilitate unit startup. The start-up vent shall be sized to accommodate 100% of the unfired steam flow generated during drum soak operation of the CTG. The start-up LP vent valve shall be a motor operated globe valve with a 10 second full stroke time, raise/lower CRT “pushbuttons” for fine positioning and a remote position indicator (LVDT). Each HRSG LP superheated steam line shall also be provided with a low-pressure drop type flow element and transmitter for measuring steam flow.

**5.2.10.4 Auxiliary Steam System**

Contractor shall provide an Auxiliary Boiler for start-up, steam sparging, and steam seals. Auxiliary boiler shall include a dedicated deaerator and 2 x 100% boiler feed pumps, all located indoors. Boiler front and controls shall be located within a building. All required auxiliary steam systems shall be furnished and installed to result in a complete, fully operational plant. Block 1 and Block 2 auxiliary steam systems shall be cross-tied together to provide steam to either unit. Auxiliary steam shall be used for start-up steam seal supply to the steam turbine, Intermediate Pressure steam to the Cold Reheat Steam System, steam jet air ejectors, and for deaerator pegging steam. The auxiliary boiler shall be backed up with desuperheated main steam from either operating unit and supplemented with cold reheat steam for the steam jet air ejectors.

**5.2.11 Condensate System**

The condensate system shall be provided as shown in the Conceptual Process Flow Diagram contained in Appendix D. The system shall deliver condensate from the condenser hotwell to the LP steam drum through the gland steam condenser, vacuum pump condenser and LP economizer; to HRSG feed pump seals; and to other related plant systems. Make-up shall be provided from the demineralized water storage tank.

Major equipment quantity and capacities shall be as follows:

<b>Equipment</b>	<b>Quantity</b>	<b>Design Capacity (each)</b>
Condenser	1	100% Peak Load system duty
Condensate Pump	2	100% of Peak load system demand

The condenser shall be a two pass design and shall be sized to condense the maximum steam turbine exhaust flow at Peak Load. Velocity through condenser tubes shall not exceed 8 ft/sec.

The condenser shall be provided with divided waterboxes to allow taking half of the condenser out of service for cleaning or repair. Condenser waterboxes shall be coated with coal tar epoxy for corrosion protection and provided with anode type cathodic protection. Piping and valving shall be provided to allow one section of the condenser to be isolated with the other remaining in operation. Motor Operated Butterfly valves shall be used to isolate the condenser from the common circulating water system for maintenance, repairs, inspection, and partial load plant operations with the other block in operation.

The condenser hotwell shall have sufficient capacity to hold 5 minutes of condensate flow at Peak Load between normal operating level and the low-level alarm. Construct condenser tubes and tubesheets of stainless steel. Tubes shall have a nominal thickness of 22 BWG welded and annealed. Roll tubes to tubesheets. Design condenser for an 85% cleanliness factor. Provide a minimum 1/16-inch corrosion allowance on the shell and waterbox. No copper components shall be used in the circulating water system.

Provide a deaerating type condenser designed to ensure that oxygen content in the condensate feeding the HRSG does not exceed 0.005 cc per liter at all normal operating conditions with 3% makeup (Minimum, Base, and Maximum Loads at any ambient condition within the operating range). Oxygen content may exceed this amount only during start-up of the unit. Provide a reheat type deaerator with steam spargers in the hotwell to facilitate deaeration during start-up. Provide a distribution header on the make-up water connection to facilitate deaeration of the make-up water. The deaeration system shall meet the requirements of the HRSG manufacture and ASME as specified in ASME publication CRDT-Vol. 34. Oversize the deaerator vent system as required to ensure adequate capacity at all condenser operating points to keep the oxygen content below the limits specified.

Level in the condenser hotwell shall be maintained by a control valve located in the hotwell make-up line. Excess condensate from the hotwell shall be returned to the demineralized water storage tank.

The condensate pumps shall take suction from the condenser hotwell and supply condensate to the LP economizer and other system demands. A control valve shall be included to regulate the condensate flow based on LP drum level using a three-element control system. Provide a factory calibrated ASME PTC 6 flow meter on the condensate pump feed to each HRSG. All steam flows shall be corrected to match the flow from this meter.

Provide a diffuser pipe inlet connection on the condenser for all steam turbine bypass connections. Diffuser pipe shall be stainless steel with a standard weight pipe wall thickness for the pipe diameter, but no less than 0.25 inches thick. Design diffuser and provide baffles to protect the condenser tubes and the steam turbine exhaust hood from steam impingement and prevent thermal shock during steam bypass. Design bypass system for continuous bypass operation.

Provide condensate pumps with stainless steel wetted parts and include duplex type suction strainer at the inlet of each pump. Condensate pumps shall be multistage, vertical, open line-shaft canned pumps with suction nozzles in the discharge head. Design pumps to operate continuously and include a minimum of 3 feet NPSH margin on pumps based upon zero (0) NPSHa at the suction nozzle of condensate pump.

A condensate system minimum flow recirculation line shall be provided and shall connect downstream of the gland steam condenser and discharge into the main surface condenser above the maximum hotwell level. This line shall be designed to provide a minimum flow recirculation protection for the condensate pump and the gland steam condenser. Each condensate pump discharge and suction connection shall be vented by individual lines back to the main condenser. During normal operation make-up to the condenser hotwell shall be supplied by vacuum drag from the demineralized water

storage tank. The demineralized water pumps shall also be designed to supply the hotwell when condenser vacuum is not available. Provide taps off of the discharge of the condensate pumps to allow for future installation of full stream filter for iron removal.

All piping, and components in the demineralized water system shall be made from corrosion-resistant stainless steel capable of handling this type of water.

#### **5.2.12 Boiler Feedwater System**

The boiler feedwater system shall be provided as shown in the Conceptual Process Flow Diagram in Appendix D. The system shall be designed to deliver feedwater from the LP drum to the corresponding HRSG HP and IP drums through their respective economizers over the full range of plant operation. The feedwater pumps shall also supply spray water to plant desuperheaters and attemperators.

Two identical boiler feedwater pumps shall be provided for each HRSG. Each pump shall be designed to provide 100% of the HRSG feedwater demand and other system demands at Base Load operation. Each pump shall be supplied with a Voith variable speed fluid coupling. For maximum Peak Load operation, both feedwater pumps shall operate to provide the total system demand for one HRSG. The HRSG feedwater pumps shall be segmented ring pumps with a main discharge providing HP feedwater and an inter-stage bleed port providing IP feedwater to the system. Using pressure letdown valves to reduce the pressure of the HP feedwater for IP service is not acceptable. The feedwater pumps shall be provided with all required auxiliary systems including warm-up system; vibration monitoring and alarms; seal water system; forced lubrication system; and NPSH protection. Provide suction strainers on each boiler feedwater pump suction inlet. Design feedwater pumps with a minimum ratio of NPSHA / NPSHR of 2 to 1 at the worst case operating or transient conditions.

Boiler Feedwater Pumps shall be equipped with Bentley Nevada vibration monitoring system - X-Y Prox Probes (2 per pump bearing) and the Key Phasor Probe (1 per pump). The boiler feed pump vibration monitoring system shall be tied in to the existing main Bentley Nevada System 1.

The Feedwater pumps shall be variable speed, electric motor driven, with hydraulic couplings. An ASME flow meter, check valve, and isolation valve shall be provided in the HP and IP discharge piping of each pump. A three-element feedwater control system shall be provided to regulate the flow of feedwater to maintain IP and HP drum level. Each pump shall have a minimum flow recirculation system that discharges into the LP drum. The recirculation system shall include a modulating control valve (no ARC valves), with a pressure break down orifice located at the LP drum, controlled from a flow element measuring suction flow through each pump. During low load, the control valve shall maintain minimum flow required for safe pump operation.

Boiler feedwater pumps shall be provided with mechanical seals. Strainers shall be installed in the suction lines to protect the pumps from damage. The strainers shall be designed with cross over capability so that either strainer can be used with either pump.

A pump warm-up line shall be provided downstream of each pump discharge isolation valve to maintain an idle pump in a ready condition while the other pump is in operation. The line shall be designed to recirculate warm water from the discharge header through

the idle pump casing back to the suction piping. A restriction orifice shall be provided in each warm-up line to maintain the warm up flow and reduce the pressure.

Boiler feed pumps shall be located in a heated/ventilated enclosure and shall be provided with a fixed monorail.

#### **5.2.13 Raw Water Supply System**

Contractor shall be responsible for obtaining all water rights, drilling and installing wells, and piping for Block 2 raw water, as required. Contractor shall provide 3x50% wells / pumps to provide raw water to the site. Raw water shall be used as make-up to the Demineralization System, evaporative cooler make-up, cooling tower makeup, and for use as plant service water. Raw water analysis shall be provided to Owner. Block 1 water analysis is provided in Appendix H, Makeup Water Analysis for Contractors information only.

Provide a Block 2 raw water storage tank and cross-tie to the existing Block 1 tank and water supply pipe. The tank shall be lined or coated carbon steel, insulated, and shall be provided with a level transmitter and indicator on the raw water tank. An inlet control valve shall be furnished on the supply to the Raw Water Storage Tank to regulate water make-up to the tank. The inlet valve shall modulate to maintain nearly constant water level in the raw water tank. Tank level control shall be based on maintaining a full tank with level indication transmitted to the control room. Block 2 Raw Water Tank shall not interfere with the fire protection water reserve in the Block 1 tank.

#### **5.2.14 Service Water System**

The Service Water System shall provide water from the Raw Water Storage Tank and distribute the water to the Block 2 service water stations. Contractor shall cross-tie the Block 1 and Block 2 systems together.

Provide service water stations within 100 feet of all areas needing service water for routine maintenance or cleaning. Provide a minimum of two service stations inside the boiler water treatment building. Provide service water to all equipment requiring service water for seal flushes or other purposes. Two 100% capacity service water pumps shall be provided. Each service water pump shall be sized to provide 100% of the plant service water needs plus not less than 50% of the maximum make-up rate required by the evaporative coolers.

#### **5.2.15 Demineralization System**

The Demineralization System shall be provided to receive raw make-up water from the Raw Water Tank and remove contaminants in the water so that it may be used as make-up to the steam cycle.

The Demineralized Water System shall be designed to produce high quality demineralized water that will not exceed the following maximum guarantee limits in the effluent of the demineralization system:

Conductivity: 0.1  $\mu$ mho/cm  
Silica: 10  $\mu$ g/l

Sodium: 10 µg/l

The following equipment shall be provided in the Demineralizer System:

Equipment	Total Quantity	Design Capacity (each)
Demineralized Water System Supply Pumps	2	100% capacity to fulfill permeate flow requirements
Multi-media Pressure Filters	1	See Below
RO Cartridge Filters	2	100% capacity to fulfill permeate flow requirements
RO Booster Pumps	2	100% capacity to fulfill permeate flow requirements
RO 1 <sup>st</sup> Pass Bank	1	100% capacity to fulfill permeate flow requirements
RO 1 <sup>st</sup> Pass Break Tank	1	As required to provide 20 minutes retention time
RO 2 <sup>nd</sup> Pass Bank	1	100% capacity to fulfill permeate flow requirements
RO Chemical Feed Pumps	2	Per chemical fed
RO Permeate Cation Exchange Resin Canister	1	100% capacity to fulfill permeate flow requirements
EDI Unit(s)	As needed	100% capacity to fulfill permeate flow requirements
Polishing Mixed Bed Ion Exchange canister	1	100% capacity to fulfill permeate flow requirements
Demineralized Water Storage Tank	1	200,000 gallons (minimum)

The raw water shall pass through the multimedia pressure filter, cartridge filters and then enter the Demineralization System. The pressure filter, RO system and EDI shall produce permeate water quality suitable for use as make-up to the steam cycle. The EDI permeate shall be transferred to a 200,000 gallon (minimum) stainless steel, demineralized water storage tank. The demineralized water storage tank shall be provided with a level transmitter and indicator, and shall be insulated.

Provide horizontal, centrifugal, Demineralizer System feed pumps. Each pump shall be sized to provide the full capacity flow rate required by the system.

The multimedia filters upstream of the RO banks shall be designed to reduce the suspended solids present in the water as required to produce filtered water with a silt density index (SDI) level suitable for use as make-up to the RO system. The multimedia filters shall consistently produce water quality with an SDI < 2.5 and turbidity < 0.5 NTU.

One (1) multimedia filter, sized for 100% of the design capacity of one RO bank, shall be provided by Contractor. Sample connections on the inlet and outlet of the filters shall be provided to facilitate the collection of grab samples. The filters shall be epoxy coated on the inside of the filter vessel. Internal piping and supports shall be constructed of Type 304 or 316 stainless steel. A differential pressure transmitter shall be provided across

the filter bed. The backwash of each filter shall be initiated automatically by high differential pressure across the filter bed, by timer, by filter throughput, or manually by the operator.

Pre-assembled, skid mounted, cartridge filters shall be provided on the inlet of the RO bank. The polishing set shall consist of replaceable 2-inch diameter, 5 micron absolute, filter cartridge elements. Provide differential pressure transmitters across each filter to alarm control system upon detection of high differential pressure. Each filter shall be sized for 100% of the brackish RO inlet flow rate.

Provide horizontal, centrifugal, RO feed pump(s) constructed of stainless steel wetted parts

The demineralizer system shall consist of a two-pass RO bank and shall be a pre-assembled, pre-piped, skid mounted, permanent on-site, RO bank consisting of standard size, universally interchangeable membranes. The system shall include RO feed pumps constructed of stainless steel wetted parts. The RO feed pumps shall be sized to provide the full capacity flow rate of an individual RO bank. The RO system shall be provided with all piping factory assembled to the greatest extent possible so as to provide a single common inlet, single common permeate discharge, and single common reject header. The RO bank shall be designed for in-place cleaning with all necessary facilities.

An inter-pass RO break tank shall be provided with a minimum of 20 minutes of retention time.

The RO system shall be furnished with all necessary chemical injection systems including but not limited to a multimedia filter aid, RO anti-scalant, RO inlet de-chlorination, and RO inlet acid feed. All chemicals will be fed directly from tote containers provided by the chemical supplier using redundant chemical injection pumps.

A caustic feed skid shall be provided for injecting caustic between the 1<sup>st</sup> and 2<sup>nd</sup> Pass RO for removal of carbon dioxide (if required). The caustic feed rate shall be automatically controlled to achieve an operator selected pH level at the inlet to the RO banks. The caustic feed skid shall consist of two (2) 100% capacity feed pumps which will feed directly from portable tote containers.

The RO System shall include a post shutdown concentrate flush on each RO bank that bypasses the reject control valve while flushing is taking place and uses RO permeate as the flushing source. RO element housings shall be constructed of FRP or stainless steel. Stainless steel piping shall be used for all interconnecting piping and headers. Sample connections shall be provided on the inlet and outlet of each membrane housing to facilitate the collection of grab samples. RO membranes shall have a minimum guaranteed life of three years in the intended service and with a minimum salt rejection of 99.5% at the beginning of membrane life with a maximum annual salt passage increase of 10% through membrane life. Pressure and flow transmitters shall be provided on the inlet and permeate header and on the reject connection of each RO bank and as required to allow tracking of membrane performance per ASTM D-4516, Standard Practice for Standardizing Reverse Osmosis Performance Data. Conductivity and pH meters shall be provided on the RO inlet and permeate headers.

Provide one 100% capacity polishing ion exchange resin canister on the outlet of the EDI permeate for final polishing of the product water. The resin shall be non-regenerable. The resin shall not need replacing for approximately 3500 operating hours.

Provide one 100% capacity, permanent on-site, EDI unit if required to minimize unnecessary regens of the mixed bed polishing unit. EDI unit shall polish permeate from the RO permeate cation exchange resin canister for make-up to the steam cycle. The EDI polishers shall be sized as required to fulfill permeate requirements. Provide a pressure transmitter on the outlet of each EDI unit. Provide a flow meter on the inlet and outlet connection of each EDI unit (EDI outlet and waste stream outlet). Provide a pH probe, conductivity probe, silica analyzer, and a temperature probe common discharge line from the EDI units to the demineralized water storage tank.

A PLC based control system shall be provided to control the Demineralizer System. The control system shall have a minimum of 32K of memory and shall include a redundant CPU. A NEMA 12 rated I/O panel and separate HMI with panel mounted CRT shall be provided as a local operator interface. The PLC shall provide high level operating parameters to the DCS system for information. All control shall be local.

The Demineralization system shall be located inside the Water Treatment Building. Storage tanks shall be located outdoors.

#### **5.2.16 Condenser Air Removal System**

The condenser air removal system shall be provided to remove air and non-condensable gases from the steam turbine condenser and vent them to atmosphere. A condenser vacuum breaker shall be provided to protect the condenser equipment and to assist in the deceleration of the steam turbine during a turbine trip.

The air removal equipment shall consist of two 100% capacity liquid ring, two-stage, mechanical pumps installed for parallel operation.

Both vacuum pumps will be used for hogging operation. One pump shall be used during normal holding operation per HEI Standards for Steam Condensers. Both vacuum pumps operating in parallel shall be capable of exhausting the condenser from atmospheric pressure to 6-inch Hg absolute in 30 minutes per HEI Standards and to 3.0 inch Hg absolute in approximately 1-1/2 hours. The vacuum pump suction performance shall be based on taking suction at 1.0 inch Hg absolute, or the condenser design pressure, whichever is lower, and discharge against atmospheric pressure. The vacuum pumps shall be oversized from HEI standards as required to maintain an oxygen partial pressure low enough in the condenser during all operating load conditions (Minimum Load through Peak Load at all ambient temperatures in the operating range of the plant) to ensure oxygen content of the condensate leaving the condenser does not exceed the limit specified in the condenser section.

Pipe sizes shall be in accordance with Table 5-1, Pipeline Sizing Velocity Guidelines, but not less than the connection size provided by the condenser manufacturer, and with less than 1 psi pressure drop between the condenser and the vacuum pumps. Suction piping design pressure shall be 50 psig and full vacuum.

A manually operated isolation valve shall be provided at the inlet of each vacuum pump for maintenance. Each vacuum pump package shall be furnished with an automatically controlled shutoff valve in the suction and a check valve in the discharge. Discharge lines from each package shall be vented to atmosphere. The water separator furnished with the vacuum pump package shall include a discharge silencer. The condenser air removal system including, but not limited to, the vacuum pumps and the vacuum breaker shall be controlled from the DCS.

**5.2.17 Circulating Water System**

The circulating water system shall be designed and constructed to provide cooling water to the steam turbine condenser and to the closed cooling water heat exchangers for the balance of the plant equipment. The circulating water is pumped from the cooling tower pump pit through the condenser and closed cooling water heat exchangers and back to cooling tower where it is cooled and collected in the tower basin.

The circulating water system shall be designed for normal operation at 4 cycles of concentration of the make-up water from the raw water system. The quality of the make-up water from the raw water system for bidding purposes is indicated in Appendix I, MAKE-UP WATER ANALYSIS. Circulating water system shall be designed to operate with a total dissolved solids concentration of near 5,000 ppm with circulating water quality as indicated in Appendix I. Cooling tower blowdown shall be discharged per the NPDES permit requirements. Major equipment capacities shall be as follows:

<b>Equipment</b>	<b>Quantity</b>	<b>Design Capacity Each Unit</b>
Cooling Tower	1	100 % Peak Load system demand
Circulating Water Pumps	2	100 % Peak Load system demand
Auxiliary Cooling Water Pump	1 or 2	100 % Peak Load system demand (See below)

The circulating water pumps shall be vertical wet pit pumps and shall be installed in a reinforced concrete intake structure, which shall be an extension of the cooling tower basin. Pump materials shall be selected specifically for the circulating water quality specified for this application. Provide an external source of flush water to the pump seals and shaft bearing for seal lubrication during start-up. Pump motor shall include a reverse rotation ratchet mechanism to prevent reverse rotation.

The circulating water pump intake shall be divided into bays with fixed removable inlet screens and provisions for installation of stop-logs or a second set of screens. Mobile crane access shall be provided for removal of the circulating water pumps, screens and stop-logs. Pump intake structure shall be designed in accordance with Hydraulic Institute (HI) standards.

Each pump shall be equipped with a motor operated isolation valve on the discharge, which shall automatically close when the pump is shut down. The operation of the motor operated valves shall be controlled by the plant DCS. The circulating water pumps shall be piped together into a common header supplying water to the condenser. A flow meter to determine daily cooling tower circulating water flow shall be provided in the common header.



Auxiliary cooling water pump(s) shall be provided in the cooling tower basin intake structure to supply cooling water to the closed cooling water heat exchangers when the circulating water pumps are out of service. Pumps shall be capable of running with the unit offline. Two 100% auxiliary cooling tower water pumps shall be provided if the circulating water system does not have adequate pressure to provide water for this service. In no case shall circulating water pump head requirements be set by the auxiliary cooling water system. Auxiliary cooling water pump materials of construction shall be selected specifically for the quality of circulating water specified.

#### 5.2.17.1 Cooling Tower

Cooling tower shall be sized to provide continuous operation at all load cases for all ambient conditions without causing the steam turbine to alarm on high backpressure.

The cooling tower shall be a forced-draft, evaporative type tower designed and constructed in accordance with the Cooling Tower Institute (CTI) standards. The cooling tower structure shall be a fiberglass design and construction using silicon bronze or monel hardware. Cooling tower structure, fill, and drift eliminators shall be constructed of materials with a flame spread rating of 25 or less when tested per ASTM E84.

The fiberglass tower structural members shall consist of structural shapes of pultruded fiberglass composites with design loads and safety factors appropriate for the specific conditions but in no case less than a safety factor of 6 applied to manufacturer's published design ultimate strength.

The tower casing shall be single wall construction secured to framework with through-bolts or lag screw with neoprene washers, and shall not be subjected to structural loading. Vertical joints shall be located a columns or vertical frame members. Corrugated board shall overlap size inches and be caulked. Drainage shall be directed to the interior of the tower.

The fan deck shall extend a minimum of 3 feet beyond perimeter of fan stack and motor. For crossflow towers, provide cover for the water distribution basins to exclude sunlight and blowing materials by extending fan deck. Provide minimum clearance of 4'-6" between hot water distribution basin walkways and extended fan deck. Enclose fan deck side and tower end wall and furnish hatches and ladders at each cell for access from deck to each distribution basin and tower plenum.

For counter flow towers provide cover over entire surfaces of the cooling tower, except at fan stack. Furnish hatches and ladders at each cell for accessing drift eliminators, tower distribution piping and nozzles, and fill from the deck.

Partition walls shall be single wall construction not subject to structural loading. Full partitions shall be from normal water level to fan deck. If baffles are provided shall extend to within 12 in. of normal water level. On crossflow towers each partition shall be provided with an access door. Fiberglass reinforced corrugated plastic panels, shall be a minimum of 8 oz/ sq ft.

Fill supports shall be adequately support fill without sag under water loading of up to 130% of design loading. Fill type shall be impact resistant, ultraviolet resistant polyvinyl chloride meeting ASTM D1784 Polyvinyl chloride shall have a nominal thickness of 15

mils. Flute height shall not be less than 0.66 inch. Fill supports shall be solid polyvinyl-chloride, glass reinforced polyester, or stainless steel

Fan stack shall be venturi type designed to minimize head loss and recover velocity head, a minimum of 8 ft. in height. Fan cylinders shall have removal segments of sufficient size to allow removal of all mechanical equipment components, and shall have a coupling guard, conforming to OSHA standards, to shroud the portion of the drive shaft that extends outside the fan cylinder. The cylinder shall be assembled into a rigid, self-supporting structure with stainless steel hardware. At least one observation opening with porthole fitting shall be provided per fan to observe fan and gear. The stack material shall be glass reinforced polyester per ASTM D1201.

The water distribution shall segment flow to individual cells and distribute water over fill at circulating water flow rates from 60% to 130% of design flow rate. For counter flow the system shall have self-draining, non-clogging, splash nozzles. Nozzles shall be accessible. The distribution header shall have clean-plug at one end. For cross flow towers, the distribution basins shall have a minimum of 3 inches of freeboard with a circulating water flow rate of 150% of design circulating water flow rate, and shall have a flow adjustment valve and distribution box for each side of each cell. Cooling Tower shall have de-icing controls. Fire protection shall be provided in accordance with local, state, and federal codes.

Fans and hubs shall be multi-blade air foil propeller design with manually adjusted pitch and be statically balanced with a tip speed not to exceed 12,000 fpm. The fan shall be suitable for reverse rotation at 1/2 speed. The reduction gear shall be in accordance with AGMA standards for Class II 24 hour continuous duty with shock load, for cooling tower service rated at 2.0 times motor rated horsepower; or CTI standard 111, which ever has more rigid requirements for gearing used. Gear boxes containing double reduction gearing consisting of herringbone and bevel gears shall be rated not less than 2.0 times motor horsepower.

Materials for the hub shall be AISI 304 ASTM A240 stainless steel, monel metal per ASTM B127, or SAI 1020 steel hot-dip galvanized after fabrication per ASTM A123 and epoxy coated.

The permissible blade material is as follows

1. Hollow-formed stainless steel per MIL-S-6721A Comp. Ti,
2. Monel metal per ASTM B127
3. Steel per SAE 1020 with a cover of stainless steel per AISI 304.
4. Cast aluminum alloy per ASTM B26, Allow SG70A
5. Stainless-steel sheets formed around heavy walled steel tube coated with baked-on epoxy resin.
6. Glass reinforced polyester per ASTM D1201, Type 5 (if molded). Hand-laid acceptable if it conforms to the flexural strength, modulus, and impact strength requirements of ASTM D1201 types.

The shaft shall be single-piece sized to transmit full rated horsepower and to be capable of withstanding shock loading due to application of brakes, and reversing of fans. Constructed of ANSI Series 300 stainless steel, ground or pickled, solid or tubular; or carbon composite shaft and coupling shall be rated not less than 2.0 times motor horsepower. Coupling shall be flexible and of stainless AISI, Series 300. Couplings

shall be non-lubricated approved type. Connecting hardware shall be stainless steel, AISI, series 300 or Inconel 625. Supports shall be structural steel ASME 36 epoxy coated.

Cooling tower basin shall be constructed of reinforced concrete and shall have a slope toward the pump pit. The cooling tower size shall be coordinated with the condenser to dissipate the heat load from the condenser and the closed cooling water system over the range of ambient conditions while maintaining the specified steam turbine backpressure at Peak operation.

Provide corrosion resistant hubs, fans, gearbox, and fan shafts. Two-speed motors shall be provided on the fans and shall be located outside of the fan stacks. Fans shall be controlled from the DCS and shall be provided with gearbox lube oil level indication and vibration monitoring. Include vibrations switches interlocked to shut down the cooling tower fans in the event of excessive vibration. Cooling tower fire protection system, if required, shall be provided in accordance with local, state, and federal codes.

The cooling tower basin shall be constructed of concrete suitable for the high sulfate and high chloride application. Concrete in contact with the circulating water shall be ASTM Type V. Special consideration shall be given to the method of form ties used during construction of the basin to ensure that all metal surfaces maintain a minimum of 1 inch of cover with concrete.

Top of cooling tower basin shall be sized to extend no less than 18 inches above the normal water level in the basin. Provide louvers as required to eliminate mist at all operating conditions. Cooling tower basin low water level alarms and trips shall be included in the DCS.

Provide drift eliminators on the cooling tower designed to reduce drift below the air permit limits. Design cooling tower with isolation valves and other mechanisms to allow one or more cells to be isolated from service without interrupting the operation of the other cells.

Provide a stair tower on one end of the cooling tower and a caged ladder on the opposite end for access to the fan deck. Construct stair tower of the same material as the cooling tower structure. Provide OSHA handrails and toe boards all around the perimeter of the fan deck. Provide access hatches and ladders in the roof deck of each cell (minimum of 2) to access the internal distribution headers. Fan deck shall be designed as a personnel platform and shall withstand a minimum uniform load of 60 psf.

Provide extended gearbox lubrication and gearbox level indication lines outside the fan stacks to allow draining, filling, and monitoring of the lube oil from outside the housing.

A cooling tower blowdown control system shall be provided to maintain the concentrations of salts and other impurities in the circulating water at acceptable levels. A blowdown control valve shall be sufficiently sized to accommodate entire cooling tower blowdown flow. Cooling tower blowdown shall be adjustable from the DCS. The blowdown control system shall proportion blowdown to cooling tower make-up with conductivity trim. Provide cooling tower circulating water conductivity and pH probes with signals connected to the DCS to automatically adjust the cooling tower blowdown

rate. Provide sample connections on the cooling tower blowdown header to facilitate collection of grab samples.

### 5.2.18 Chemical Injection Systems

Chemical feed equipment shall be provided to supply water-conditioning chemicals to the boiler steam/water cycle systems and the circulating water system. Each system shall be skid-mounted and shall include chemical pumps, piping, instrumentation and controls. All chemical feed systems shall be designed to feed a neat solution directly from the portable tote container provided by the chemical supplier or bulk chemical storage. All chemical tanks and totes shall be provided with containment to prevent contamination due to chemical leakage. All containment areas shall be sloped to drain to a sump providing convenient suction for the use of portable sump pump or vacuum truck hose. All chemical feed systems shall be monitored, controlled and injection rate adjusted from the plant DCS. Wherever possible, chemical feed pumps shall be identical. All chemical feed systems shall be designed for 100% of the maximum Peak Load steam flow.

#### 5.2.18.1 Boiler Water Chemical Systems

The boiler steam/water cycle chemical injection systems shall provide tri-sodium phosphate treatment for injection into the IP and HP drums and hydrazine and ammonia injection to the condensate and feedwater systems. Chemical feed equipment and totes shall be located inside a heated and ventilated building and shall be arranged to allow clear access to the chemical tanks with a fork truck or other suitable maintenance equipment through roll-up doors directly adjacent to the chemical tote containers. Chemical feed system shall be segregated from all other systems in the building with a barrier wall. Provide adequate ventilation to prevent the accumulation of chemical fumes per Industrial Ventilation Standards. Provide facilities suitable for stacked 500-gallon hydrazine and ammonia supply totes and for a minimum of two carboys of dry phosphate storage. Fork lift access shall be provided for tote change-out and unencumbered safety exits shall be provided from all normal operating/maintenance areas in the chemical area.

A tri-sodium **phosphate feed system** shall be provided for each HRSG to buffer the boiler water and control pH. Each phosphate system shall consist of a solution tank with mixer and three 100% metering pumps with manual stroke positioners. Quicklock connections shall be furnished on the common suction of the metering pumps to allow direct connection to portable tote containers. One dedicated pump will supply phosphate to the HP drum and a second pump to the IP drum. The third pump will serve as a common spare. The common spare pump shall have added capacity to provide a higher solution feed rate to either drum during startup conditions. Dilution water used for filling the solution tank shall be demineralized water or condensate. Control of the pumps shall be start/stop from a local control panel. The system shall be controlled so that the pumps shut down if the feedwater flow rate drops below a preset minimum flow rate.

The **hydrazine** injection system shall consist of two 100%-metering pumps with variable speed drives and manual stroke positioners. One pump shall feed hydrazine directly from a portable chemical tote to the condensate pump discharge with the second pump acting as a spare. The portable tote will be supplied by the chemical supplier. Control of the hydrazine feed shall be in proportion to condensate flow. The system shall be cross-

tied to the condensate pump to prevent operation when the condensate pumps are out of service. Tote shall be vented outdoors.

The **ammonia** feed system shall be provided to maintain a high pH level and shall consist of two 100% metering pumps with variable speed drives and manual stroke positioners. One pump shall feed amine directly from a portable tote or an on-skid dilution tank to the steam cycle with the second pump acting as a spare. The portable totes will be supplied by the chemical supplier. Control of the ammonia feed shall be in proportion to condensate flowrate. Tote and dilution tank shall be vented outdoors.

#### 5.2.18.2 Circulating Water Chemical Feed

The circulating water chemical feed equipment shall be provided to supply water-conditioning chemicals to the circulating water system for biological growth, scaling and corrosion control. The circulating water chemical feed system consists of a sodium hypochlorite feed system, an acid feed system, and a corrosion inhibitor feed system. The acid and hypochlorite feed systems shall include bulk chemical storage tank sized for a minimum of 30 days of storage at Peak Load operation or 1.5 times bulk delivery volume, whichever is larger. The corrosion inhibitor shall each be stored in a permanent 1500 gallon bulk storage tank. Circulating water chemical feed systems shall be located inside a heated/ventilated building adjacent to the cooling tower. Contractor shall provide freeze protection as required for any circulating water chemical feed tanks or distribution lines located outdoors.

A **sodium hypochlorite** feed system shall be provided to feed a biocide solution to the cooling tower structure on a continuous basis and shock feed capability to each tower cell (riser). The sodium hypochlorite feed system shall consist of an FRP bulk storage tank, two (2) 100% capacity metering pumps with automatic stroke positioners, one (1) pump with manual stroke positioner, and hypochlorite diffusers located below the waterline of the cooling tower basin. The two pumps with automatic stroke positioners shall continuously feed biocide to the cooling tower basin. The pump with the manual stroke positioner shall be provided to feed biocide on a shock basis to each riser of the cooling tower cells. The continuous biocide feed shall be automatically controlled from the DCS based on the halogen residual desired in the circulating water and monitored at the condenser outlet. The shock feed to the individual cells shall be manually initiated. Once manually initiated the feed period shall automatically terminate after an adjustable timed period.

A **sulfuric acid** feed system shall be provided to inject sulfuric acid into the cooling tower make-up for alkalinity control. The feed rate shall be proportional to make-up water flow and biased by circulating water pH. The system shall consist of a bulk storage tank and two (2) 100% metering pumps with automatic stroke positioners. One pump shall be in service with the second pump serving as an installed spare. Sulfuric acid shall be fed to a non-metallic mixing trough located in the cooling tower basin.

The sulfuric acid storage tank shall be a horizontal carbon steel tank with dished heads and designed for atmospheric pressure. The tank material shall be carbon steel (ASTM A-283, Grade A or ASTM A-516 Grade 70). The internal surface of the tank shall be lined with a baked phenolic coating suitable for sulfuric acid service. A desiccant breather shall be furnished on the tank vent line to prevent moisture from entering the tank.

All dilute sulfuric acid piping and valves shall be Alloy 20 construction. The controlled volume pumps shall be provided with all wetted parts of Alloy 20 construction and with Alloy 20 or TFE diaphragms.

A **corrosion inhibitor** feed system shall be provided. The system shall include one bulk storage tank and two (2) 100% metering pumps with automatic stroke positioners for each chemical. Feed shall be proportional to cooling tower blowdown flow. One pump shall be in service with the second pump serving as an installed spare. A bulk chemical storage tank shall be a vertical polyethylene tank designed for a specific gravity not less than 2.0. The minimum tank volume shall be 1500 gallons.

**5.2.19 Closed Cooling Water System**

Contractor shall provide a closed cooling water system for the power block to supply cooling water to the various generation plant equipment heat exchangers and transfer the heat to the circulating water system through the closed cooling water heat exchangers. System operating pressure at the heat exchangers shall be higher than the circulating water system to prevent leak contamination. A 5-gallon chemical feed mixing pot system shall be provided to maintain water quality and inhibit corrosion.

Contractor shall provide closed cooling water pumps on each system with sufficient pumping capacity to supply cooling water to both CTG/HRSG trains, the steam turbine generator, and associated balance of plant equipment, at all operating conditions.

Major equipment capacities shall be as follows:

<b>Equipment Item</b>	<b>Quantity</b>	<b>Capacity of Each Unit</b>
Closed Cooling Water Pump	2	100% maximum system demand
Closed Cooling Water Heat Exchanger	2	100% maximum system demand
Closed Cooling Water Head Tank	1	As required
Closed Cooling Water Chemical Feed Mixing Pot	1	As required

The closed cooling water heat exchangers shall be plate and frame. Each exchanger shall be designed for a maximum pressure drop of 10 psi on each side (5 psi preferred). Closed cooling water heat exchanger material for all wetted surfaces shall be of 317L construction. Contractor shall provide a thermowell on each heat exchanger inlet and outlet connection and provide pressure gauge taps on each inlet and outlet connection.

Contractor shall design the closed loop cooling water system for a mixture of no less than 45% propylene glycol solution. Provide concrete containment around the CCW pumps and heat exchangers with a 6-inch curb all around.

The system shall be designed and constructed so that one pump is started manually from the main control room and runs continuously during normal operating conditions. System operation shall be a permissive for CTG / STG operation. The other pump shall be on auto standby. A pressure switch in the pump discharge header shall be provided to initiate an automatic startup of the standby pump if discharge pressure is below a

predetermined pressure setting. Selection as to which pump will be on standby shall be a manual operation.

The head tank shall be designed to maintain the required system pressure, accommodate flow variations, and allow system thermal expansion. The head tank shall be vented to the atmosphere and located at the highest point in the system to provide adequate pump NPSH. As an option the head tank may be pressurized by the nitrogen gas system. The pressurization system shall be automated and controlled by the tank set pressure.

In order to prevent or minimize corrosion of any of the closed cooling water system components, a corrosion control system shall be provided. The system shall be designed as a batch system in which the required chemicals are flushed into the system by means of a manually operated chemical feed mixing pot.

#### **5.2.20 Fuel Gas System**

The fuel gas system shall receive gas from the plant metering station in a range of pressures indicated in Section 2 of these specifications. Provide all gas heating, moisture removal, particulate filtration, and pressure regulation required to deliver the gas to each individual GTG fuel gas control system and HRSG duct burner and pilot at the proper conditions as required by GTG and duct burner manufacturers.

Provide a check meter on the main gas supply to the Site as a secondary check to the natural gas supplier's revenue meter. Connect the meter to the DCS for historical trending of the information and totalizing of the flow.

Fuel gas supply system shall be designed to ensure that the GTG manufacturer's fuel gas requirements for contaminants are met, given the worst case fuel that may be delivered to the facility; and to provide filtered, dry natural gas to the GTG and HRSG.

The Fuel Gas System shall be designed to meet all requirements and recommendations of NEC, NFPA, Factory Mutual, and local codes.

The fuel gas distribution system shall have sufficient capability to operate all GTGs and HRSG duct burners simultaneously at Peak output at any ambient condition with the design basis fuel gas composition defined in Appendix J.

Provide a fuel gas scrubber, primary and secondary (if required) fuel gas heaters, and a filter/separator for each GTG. The fuel gas scrubber shall be installed upstream of fuel gas heaters. Filter/separator should be installed downstream of the fuel gas heaters. Provide a filter/separator that is designed to satisfy the GTG manufacturer's limits on particulate matter and liquids. Each fuel gas scrubber and filter/separator shall come complete and skid mounted with automatic level control to maintain a safe level of accumulated liquids. Separated liquids shall be drained to collection tanks for subsequent removal. The drain tanks shall have level indication that is provided to the plant DCS. All materials in contact with the clean gas stream inside the filter/separators and downstream of the filter/separators shall be constructed of 300 series stainless steel materials.

Provide dedicated primary fuel gas heaters on each GTG unit. Primary fuel gas heaters shall be shell and tube heat exchangers, utilizing waste heat or low energy heat where possible as a heating medium. Design system to preheat fuel gas to a temperature required by the OEM under all load and ambient conditions prior to supply to the GTG fuel gas skid. Provide a temperature probe in the heated gas stream and temperature control valve in the condensate return line to afford temperature control of the natural gas. Scope of supply for the fuel gas heating system shall include, but not be limited to, heaters, heat exchangers, piping, valves, controls, drain tanks, expansion tanks, and safety relief valves.

If required, provide a secondary electric fuel gas heater on the fuel gas stream to each GTG, designed to provide fuel at the temperature required by the GTG manufacturer during startup (dewpoint heating).

Provide DCS controls and all instruments necessary to monitor temperature of fuel gas supply from the primary fuel gas heaters and automatically initiate and control the secondary fuel gas electric heaters to maintain the fuel gas temperature above the minimum allowed by the GTG manufacturer during start-up. Provide an alarm in the DCS for low fuel gas temperature.

Supply regulated gas, at the required GTG inlet supply pressure, to the GTG fuel gas control system. Provide all pressure regulation equipment required. Provide a branch line to the HRSG duct burners with pressure reduction control valves to reduce the inlet gas supply pressure to that required by the HRSG duct burners.

Provide flow measurement instruments on each fuel gas supply line to each GTG and each fuel gas supply line to each HRSG duct burner. Fuel gas metering to each duct burner and to each GTG shall meet the requirements of 40 CFR 75 for reporting.

The system shall be sized to meet the design capacity requirement with the gas supply pressures at minimum levels. The system design pressure downstream of regulators shall be at least 550 psig, but shall be selected by Contractor during detailed design based on the maximum gas supply pressure. Pressure safety relief valves shall be included as required to prevent the pressure from exceeding maximum system design pressure (including safety valve accumulation) or as required to protect supplied equipment or systems. Design temperature shall be equal to the maximum operating temperature plus a 10°F margin. Provide an automated emergency vent valve in addition to the safety relief valves. Provide a pressure switch with a set point sufficiently below the relief valve set pressure to close the site pressure regulators and open the emergency vent valve prior to lifting the relief's during a system upset. Locate and direct all vents (emergency and reliefs) away from buildings or occupied areas.

Route all fuel gas piping so that piping is not below any ponds or permanent structures.

The fuel gas distribution system shall have sufficient capability to operate all CTGs and HRSG duct burners simultaneously at Peak output at the Minimum Ambient Design Dry Bulb temperature with the design basis fuel gas composition defined in Appendix J. The following equipment shall be provided to supply conditioned fuel gas:



Equipment	Quantity	Capacity of each unit
Scrubber	1	1 x 100% of Maximum Fuel Demand
Reciprocating Gas Compressors	3	3 x 50% CTG fuel demand
Secondary Start-up Fuel Gas Heaters	2	One per CTG
Primary Performance Fuel Gas Heaters	2	One per CTG
Fuel Gas Knock Out Tanks	2	One per CTG
Filter Separators	2	One per CTG

The fuel gas scrubber shall be installed on the main fuel gas supply header upstream of the branch lines for duct burner fuel supply and the fuel gas compressors. Filter/separator should be installed downstream of the fuel gas heaters. The fuel gas knock out tank shall be installed downstream of the fuel gas heaters and upstream of the filter/separator. Refer to Appendix D for the conceptual fuel gas flow path.

### 5.2.21 Compressed Air System

Compressed air systems shall be designed and constructed to supply filtered, dry, and oil-free compressed air to the plant service air system and to instrumentation and pneumatic control devices via the instrument air system. The following major equipment shall be provided to supply compressed air when the plant is out of service and during system start-up. Both service air and instrument air shall be provided from a common air receiver. Air receivers shall be located as required by Contractor's design for Block 2 Equipment. Block 2 compressed air system shall tie into the existing Block 1 system.

Equipment	Quantity	Capacity
Air Compressor	2	100% Peak system demand
Service / Instrument Air Receiver	2	To level out demand on the Air Dryers and 10 minutes of demand (See Below)
Service / Instrument Air Dryer	2	100% peak system demand

The air compressors shall have sufficient capacity to supply the maximum service air and instrument air required during normal operation and maintenance outages including adequate air to clean one of the GTG inlet air filter systems when the GTGs are shut down. The compressor shall provide oil-free (less than 0.05 ppm oil) air at a discharge pressure of 125 psig. Design system to maintain a normal supply header pressure of 115 psig and design all components to operate properly at a minimum supply pressure to each instrument and air user of 80 psig. Service air supply shall be provided with a low pressure cut-off.

Provide service air hose stations including 100 feet of hose within 100 feet of all areas requiring routine or periodic maintenance with compressed air tools or with compressed air.

Compressed air receivers shall be supplied with a relief valve and shall be ASME Section VIII, Division 1 code stamped and designed for 150 psig. Compressed air receivers shall be provided with sufficient volume to provide 10 minutes of air supply at

the design demand rate without the pressure falling below 70 psig with all compressors failed.

The compressor shall be supplied with an inlet filter-silencer and discharged through an aftercooler and moisture separator. The compressor, intercooler, and aftercooler shall be air-cooled. The compressors shall discharge to the common dessicant type air receiver that is sized so that the compressors do not run continuously or in short cycle. The air receiver shall be designed to remove additional moisture.

The air compressors shall operate automatically to maintain the air receiver pressure within an acceptable range and shall be tied into the Block 1 system. In AUTO mode, the lead compressor shall start on low air receiver pressure and shall stop on high pressure. In the event that the lead compressor cannot maintain the minimum allowable pressure, the standby compressor shall start automatically, and a low-pressure alarm shall be activated in the main control room. A selector switch shall be provided in the DCS to establish the lead compressor and the standby compressors. Remote indication and set point selection capability shall also be provided in the DCS. Air compressor load shall be served off a critical service panel so that the compressor can be operated when the plant is down.

The compressed air stream shall be filtered and dried to a dew point of -40°F. A second receiver shall be supplied to level out instantaneous demand on the instrument air dryers. The dessicant type dryers shall be fully automatic and permit uninterrupted flow through the desiccant charge during regeneration. The instrument air stream flows through the heatless dryer, which shall include prefilters, afterfilters, and an arrangement of piping and manual isolation valves to allow continuous filtering during the replacement of one set of filter cartridges.

A pressure-regulating valve shall be provided to shutoff air supply to the service air system when low compressed air system pressure jeopardizes operation of the instrument air system.

#### **5.2.22 Sampling and Analysis System**

A Sampling and Analysis System shall be provided to monitor the performance and operation of the steam, condensate, and feedwater cycles; to monitor the quality of various process fluids; and to provide sufficient data to operating personnel for detection of any deviations from control limits so that corrective action can be taken. Sampling and analysis system shall be located in a heated and ventilated area.

The sampling and analysis system shall be designed to condition samples by pressure and temperature reduction and to measure flow, temperature, pressure, cation conductivity, specific conductance and pH, silica and O<sub>2</sub>.

Samples shall be taken from various process points in the power block and routed to a centrally located sample panel. At the panel, pressure reduction shall be accomplished by pressure reducing valves. Isolation valves shall be provided for each sample point on the sample panel to facilitate maintenance. Temperature reduction shall be accomplished by sample shell and tube coolers utilizing closed loop cooling water for primary cooling. Provide a chiller system for secondary cooling to control temperature to 77°F (+/- 1°F) of all samples over 120°F. Provide provisions at the sample panel for

continuously flowing grab samples for each sample. Sample wastes shall be directed to the boiler blowdown collection system.

The samples shall be directed to automatic analyzers mounted in a NEMA 12 panel and the results displayed and recorded. Provide a prefabricated air conditioned enclosure for housing the steam cycle sample panels. The following sample points shall be included for monitoring, samples listed are per unit unless otherwise specified:

## Lake Side Water Sampling System

Service	GS	SC	CC	DC	DO	pH	Si	Na	ORP	
<b>HRSG-A</b>										
Condensate	X				P					
Boiler feed pump suction	X				P					
LP steam	X		X			X	P	P		
IP boiler drum	X	X	X			X				
IP boiler steam	X		X			X	P	P		
HP boiler feed water	X	X	X	X	X	X			X	
HP boiler drum	X	X	X			X				
HP boiler main steam	X		X	P		X	P	P		
Hot reheat	X		X							
Evap Cooler Sump*	X	P				P				
<b>HRSG-B</b>										
Condensate	X				P					
Boiler feed pump suction	X				P					
LP steam	X		X			X	P	P		
IP boiler drum	X	X	X			X				
IP boiler steam	X		X			X	P	P		
HP boiler feed water	X	X	X	X	X	X			X	
HP boiler drum	X	X	X			X				
HP boiler main steam	X		X	P		X	P	P		
Hot reheat	X		X							
Evap Cooler Sump*	X	P				P				
<b>Common</b>										
Condensate pump discharge	X	X	X	X	X	X	P	P	X	
Common hot reheat	X		P					P		
Make-up Demin	X	X					P	P		
Main steam	X									
Evap Cooler Makeup Tank*	X	P				P				
Common LP steam	X									
	<b>GS</b>	Grab Sample				<b>Si</b>	Silica			
	<b>CC</b>	Cation Conductivity				<b>SC</b>	Specific Conductivity			
	<b>DC</b>	Degassed Cation Conductivity				<b>DO</b>	Dissolved Oxygen			
	<b>Na</b>	Sodium				<b>P</b>	Patch Point			

All sample lines shall provide grab samples.

One boiler silica analyzer shall be provided to be shared between the high pressure and intermediate pressure boiler water samples. One high purity silica analyzer shall be provided and shared by the high pressure and intermediate pressure steam samples. One dissolved oxygen analyzer shall be provided for analysis of either the condensate or boiler feed pump discharge samples.

In addition to display of monitored values, visual and audible annunciation of abnormal water quality and chemical feed conditions shall be provided. Recording shall be accomplished by the DCS for display in the main control room.

Sample lines and valves shall be designed and fabricated in accordance with requirement of systems from which they originate. The sampling and delivery piping, sample coolers, tubing, valves and the sampling sink shall be of stainless steel construction to minimize corrosion. Direct all blowdown from the sample analysis system to the boiler blowdown system for disposal in the cooling tower. Steam sample connections shall be provided with isokinetic sample probes.

Include personnel protective devices to protect personnel from all hazards.

### **5.2.23 Fire Protection System**

Contractor shall extend the yard fire water loop system around the new plant. No new fire water pumps are required. Provide a complete new fire protection system for the new plant that includes the fire water supply and distribution system, FM 200 systems, portable fire extinguishers, fire detection, alarm, actuation, and signaling systems. The fire water system capacity shall be at least equal to the flow rate required for the largest single fire hazard, plus a 500 gpm allowance for each of two hose streams. All fire protection systems and components shall be designed and supplied in accordance with the appropriate requirements of NFPA, UL, FM, and the local Fire Marshall. The systems shall receive the approval of Owner's insurance carrier.

The engineer responsible for the fire protection system shall be a practicing fire protection engineer registered as a Professional Engineer in the State of Utah. All drawings and specifications shall be signed and sealed by the Professional Engineer.

The underground fire main shall be extended from the existing site system and shall be a minimum of 10-inch diameter and shall supply firewater throughout the generation plant area. The fire main shall be looped and shall supply water to fire hydrants, hose stations and fixed water suppression systems installed in buildings and elsewhere around the plant. The piping network is configured in a loop so that a piping failure can be isolated with shutoff valves without interrupting the supply of water to a majority of the loop. Provide fire hydrants at a maximum of 250-foot spacing and protective bollards around all hydrants.

The fire protection and detection systems requirements for specific plant locations are summarized in Table 5-2.

Firewalls, if required in Table 5-2, shall be in accordance with NFPA 850.

All fire water piping and components 3/4" and smaller that are exposed to freezing conditions shall be freeze protected.

Portable CO<sub>2</sub> and dry chemical fire extinguishers shall be provided in the Maintenance Building and other areas requiring handheld fire protection.

All local alarm, detection and suppression panels shall report status to the main fire alarm panel located in the control room. All alarms shall be indicated in the control room, as well as locally and as required by Code.

#### **5.2.24 Potable Water System**

Extend the existing potable water system to the new Block 2 plant to distribute potable water to various users located around the generation plant. Areas requiring potable water include various chemical storage areas and battery rooms requiring eyewashes and or showers around the plant. Provide pressure or flow switches for each eyewash station to alert operators when a station is activated. The operating pressure shall be controlled between 60 and 90 psig. Drinking fountains shall be included.

The maximum potable system demand shall be determined in accordance with the Uniform Plumbing Code for the fixtures and shall include a 30 gpm allowance for eyewash stations and safety showers.

Potable water system shall receive water from the local municipal system. The potable water system shall be designed to provide potable water, both hot and cold, at the proper pressure, temperature and flow rate to all plumbing fixtures and equipment. All instrumentation shall be controlled by the DCS control the system. Potable water piping shall be insulated as required. Provide back flow preventers on all service water branches from the potable water system.

**TABLE 5-2  
Plant Fire Protection and Detection Systems**

<b>Plant Location</b>	<b>Type of Fire Protection</b>	<b>F</b>
Boiler Feed Pump Enclosure	Handheld extinguishers	Smoke/he
chemical storage buildings	Fixed, automatic, wet-pipe sprinkler, closed head	Smoke/he
Sample analysis / CEM enclosure	Handheld extinguishers*	Smoke/he
Steam turbine lube oil tank, lube oil piping, bearing housings, and where oil can accumulate	Fixed, automatic, dry-type, open head, deluge system	Heat detect
Main (Generator Step-up) and station service transformers	None Provide fire walls if located within 50 feet of other facilities	None
Gas turbine generator	CO <sub>2</sub> system supplied by the CTG manufacturer	Supplied manufacturer
Switch yard control building (Building is provided by Others. Fire protection shall be provided under this contract).	Handheld extinguishers or as required by the local fire marshal.	Smoke/he

\* or as required by local fire marshal

Provide safety showers and eyewash station at all chemical storage locations, ammonia storage locations, in the battery room, at SCR ammonia injection skids, and elsewhere where emergency showers are required per OSHA and where normally installed in a combined cycle power plant. Safety shower system shall be designed and constructed to meet OSHA requirements. Potable water at safety showers and eyewash stations shall be tempered water between 60°F and 95°F. Provide thermal relief valves on all safety showers and eyewash stations. Provide flow or pressure switches on all eyewash stations and safety showers. These flow or pressure switches shall alarm in the control room when the safety shower or eyewash station is activated.

#### **5.2.25 Process Bulk Gas Storage and Distribution System**

The process bulk gas storage and distribution system described in this section is for use in the plant process systems and is in addition to the CO<sub>2</sub> fire protection system provided with the GTG or any other CO<sub>2</sub> fire protection systems provided at the request of the local fire marshal.

All process bulk storage systems shall be located under cover for sun protection.

The hydrogen storage and distribution system shall be provided to supply hydrogen for generator makeup during normal operation and for initial filling. Hydrogen will be stored in cylinders mounted on a mobile trailer to be provided by Owner's hydrogen supplier. Contractor shall provide a hydrogen storage trailer pad sized for two trailers. Contractor shall coordinate the design of the hydrogen storage system with the Owner's hydrogen supplier, install the complete system, including foundations and utility requirements, ready to receive the hydrogen gas and shall commission the complete system.

Contractor shall provide a bottled carbon dioxide distribution system to supply carbon dioxide for purging the generator casing to remove air and hydrogen during outages to prevent an explosive hydrogen mixture. Carbon Dioxide will be stored in cylinders mounted on a mobile trailer to be provided by Owner's carbon dioxide supplier. Contractor shall provide a carbon dioxide storage trailer pad sized for two trailers. Contractor shall coordinate the complete design of the carbon dioxide storage and distribution system with the Owner's carbon dioxide supplier, install the complete system ready to receive the carbon dioxide gas and shall commission the complete system with assistance as required from Owner's carbon dioxide supplier. The bottle storage trailers for Block 2 shall provide sufficient storage for four gas turbine generator purges. The Contractor shall provide a sun shelter over the bottle storage trailers.

Storage racks, manifolds, and pressure regulating stations for nitrogen gas bottles shall be provided and installed at each HRSG for the supply of nitrogen inerting gas. The nitrogen storage racks shall have sufficient capacity to blanket one wet HRSG for one month. The systems shall have sufficient capacity to adequately blanket a wet HRSG within 4 hours.

Nitrogen may also be supplied to the closed cooling water system head tank for pressurization as necessary for the Contractor's design. If required for other than long-term lay up of equipment, Contractor shall provide permanent facilities for Nitrogen storage.

Pressure control units shall be provided to regulate gas flow to meet system capacity requirements and satisfy minimum inlet pressure requirements at each user. The system design pressures upstream of the pressure control valves shall be equal to the storage system's design pressure. The header pressure of each bulk gas system shall be monitored on the plant DCS. Provide relief valves downstream of the pressure control valve as required to protect the piping from a regulator failure.

#### **5.2.26 Waste Water Collection and Transfer System**

The wastewater collection and transfer system shall be provided to collect, treat, and dispose of the facility wastewater streams including the following:

1. Sanitary wastewater
2. Oily wastewater
3. Gas turbine water wash
4. Process wastewater
5. Wastewater discharge

All waste lift stations shall be open concrete sumps covered with grating. Sump pumps shall be installed in 100% capacity pairs. Sump pumps shall be vertical sump pumps with the motor installed above the sump grating.

##### 5.2.26.1 Sanitary Wastewater

The sanitary wastewater shall be collected from the various points of origin in the facility and delivered to the local sanitary sewer system. The system shall be sized to meet the requirements of local code.

The sanitary drainage system will consist of a system of manholes, sewer lines, and pump stations draining from all sanitary waste facilities to the City sewer system. These flows will be limited to waste water from personnel rest room facilities, and uncontaminated general plant drainage. No plant drains, run-off or wash down water will be discharged to this system.

##### 5.2.26.2 Oily Wastewater

Plant wastewater that has the potential for oil contamination shall be collected and routed through an oil water separator. Oil water separator shall be in accordance with the following paragraph:

Oil water separator shall be a double wall vessel in accordance with API 421 standards and UL 58. Separator shall include sufficient corrosion protective coatings or shall be fiberglass and shall be provided with a minimum of two manways for access to the front and back portions of the separator. Manways shall extend to grade with gasketed covers. Internal components requiring maintenance shall be designed to be removable from the manways. The separator shall be capable of removing entrained oil to a maximum instantaneous concentration of 10 ppm. A level probe with high level switches and leak detection devices shall be provided. This system shall be designed so that separated oily waste can be removed by Owner via vacuum truck.



Separated wastewater shall be combined with the sanitary wastewater and discharged to the local city sanitary sewer system.

5.2.26.3 CTG Water Wash

The CTG water wash system shall be provided with a double wall, steel inner and fiberglass outer, holding tank or a single wall steel tank in a concrete sump for each CTG. All steel tanks shall have the inter surface lined or coated with a material suitable for the application. The tank shall be sized to contain the wastewater from one complete CTG water wash cycle. The tank system shall be provided with connections and designed for vacuum truck removal.

5.2.26.4 Process Wastewater

Process wastewater from the HRSG blowdown tank and CTG evaporative cooler blowdown shall be recovered in the cooling tower basin. Hot process drains shall be cooled before introduction into the hot drain system. Hot drain piping shall be designed to accommodate temperatures up to 212°F. Plant hot drains, reverse osmosis reject, make-up demineralizer waste water drains, and cooling tower blowdown shall be routed to the waste water collection and transfer sump. These combined waste streams shall be pumped from the waste water collection and transfer sump to the sanitary sewer system.

5.2.26.5 Wastewater Discharge.

The plant wastewater discharge shall be monitored and measured as required by the plant wastewater permits and all applicable federal, state and local codes, including but not limited to revenue quality flow meter, pH and temperature. A flow-proportioned composite sampler shall be furnished on the discharge of the waste water collection and transfer sump. Provisions shall also be made to provide grab samples. All waste streams shall be directed to the locations indicated above.

**5.2.27 Heating, Ventilating, and Air Conditioning System**

The heating, ventilating, and air conditioning (HVAC) systems for the plant shall satisfy the workspace environmental requirements for personnel occupancy and equipment operation. Temperatures shall be maintained well below operating limits so that equipment reliability will not be jeopardized.

The ambient design conditions for the HVAC Systems shall be selected by Contractor based on ASHRAE data for the plant location.

The type of HVAC System in specific locations is summarized below:

AREA	Qty of Units	TYPE OF SYSTEM
Electrical Equipment Area	2 x 100%	Air-Conditioned for equipment requirements.
PLC Enclosures	1x100%	Air-Conditioned for equipment requirements.
Battery Room	2 x 100%	Heated and Ventilation for equipment requirements. Explosion proof construction.

Electronics Room	2x100%	Air-Conditioned for equipment requirements.
CEMS Shelters	2 x 100%	Air-Conditioned for equipment requirements
Sample Analysis Shelters/ Chemical Feed Shelters	1 x 100%	Heated and ventilated for equipment
Boiler Feed Pump Enclosure	1 x 100%	Heated and ventilated for equipment requirements. Explosion proof construction.
Offices (Outside of Admin)	1 x 100%	Air-Conditioned for personnel comfort and equipment requirements.

The indoor temperature design conditions in the electronics enclosures shall be in accordance with equipment operating requirements with a maximum summer high of about 70°F. The indoor and outdoor design temperatures in non-process areas shall comply with applicable local energy code requirements. As a minimum air-conditioning systems be designed to maintain an indoor office maximum summer temperature of 75°F. Heating systems shall be designed to maintain comfortable space temperatures during normal winter plant operations.

Ventilation systems shall be designed to provide adequate ventilation air to dissipate the excess heat developed by the plant equipment and components during plant operations. Ventilation systems for chemical storage areas shall be designed in accordance with Industrial Ventilation Standards to keep chemical concentrations in the air within acceptable limits.

The battery room ventilation system capacity shall be based on limiting the maximum hydrogen concentration to 2% or less of the total battery room volume while maintaining and acceptable internal temperature. Battery room air shall be exhausted continuously by a spark-proof exhaust fan (with a spark-resistant fan wheel and explosion-proof motor) to maintain a low level of hydrogen concentration. Provide a hydrogen detector for the battery room and connect to the DCS, either directly or through the fire detection system.

Air velocities in ducts and from louvers and grills shall be sufficiently low so to maintain acceptable noise levels in areas where personnel are normally located. Roof ventilators shall be low noise type to minimize impact of plants overall noise emissions.

Thermal insulation with vapor barrier shall be provided on ductwork surfaces with a temperature below the dew point of the surrounding atmosphere to prevent vapor condensation. All ductwork used for air conditioning purposes shall be insulated; ductwork used for ventilation purposes shall not require insulation.

Exhaust systems shall be provided for toilet and shower areas. Outdoor ventilation air shall be based on a minimum of 20 cfm per person based on normal room occupancy or local codes, whichever is more stringent.

## 5.3 PLANT PIPING REQUIREMENTS

### 5.3.1 General Requirements

This criteria covers the requirements for the design, fabrication, installation and protection of all plant piping. Contractor shall be responsible for the mechanical design of the piping system, pipe stress analysis, and pipe supports. Upon request, all design criteria and calculations shall be provided to Owner for review.

All piping shall be designed, fabricated, installed, examined, and tested in accordance with applicable local codes and the applicable sections of ANSI B31.1 for power piping, B31.1 for fuel piping, and the ASME Boiler and Pressure Code, Section I for critical boiler related piping.

Process pipe sizing shall be based on the following factors:

1. Maximum line velocity as defined in Table 5-1.
2. Piping layout and configuration.
3. Economic evaluation considering piping material cost and pumping energy costs.
4. Quality of material handled (clean, sedimentation, etc.).
5. System operation (continuous or intermittent).
6. Minimize flashing, noise, vibration, water hammer, deflection, and erosion over the full range of operation, including startup and shutdown.
7. Minimum pipe size shall be 3/4 inch, except for connections to equipment. Pipe sizes 1-1/4 inch, 2-1/2 inch, 3-1/2 inch, 5, 7 and 9 inch shall not be used except for connections to equipment.

Pipe racks shall be located on the side of each HRSG. The plant layout shall be in general conformance with the preliminary layout drawings provided in these specifications.

All potable water piping shall be sterilized in accordance with AWWA standards for disinfecting purposes prior to filling.

Run all lines parallel to building lines and equipment centerlines. Group parallel lines to the greatest extent possible for support from a common pipe support system.

General service piping shall be installed with north/south runs at one elevation and east/west runs at another elevation. Where change in direction occurs a minimum of 1 foot 6 inches (3 foot on lines above 6 inch NPS) elevation change shall be provided. Exceptions to this requirement will be allowed on the main steam piping (HP steam, Hot Reheat, Cold Reheat, and LP steam).

Provide sufficient unions and flanged connections to permit dismantling of equipment, automatic valves, and instruments for routine maintenance.

Slope all vent lines and gravity drain lines to provide a minimum of 1/8 inch per foot slope in the direction of liquid flow.

Pump suction and discharge piping shall be at least one pipe size larger than pump connection. Provide spool pieces between pump and isolation valves to permit removal of the pump without removing block valves. Install eccentric reducers with flat side on top at all pump suction. Do not install pockets in piping on pump suction that would trap liquids. Pump suction piping shall be in accordance with Hydraulic Institute recommendations.

Provide seamless pipe with welded joints unless otherwise specified or approved by Owner.

Provide steam drain assemblies at all pocketed low points, at dead ends, and at intervals along main steam lines to be determined by Contractor to ensure adequate condensate removal during system warm-up and compliance with ASME TDP-1.

Provide spare valved instrument air taps on instrument air line a minimum of every 20 feet where instrument air headers are routed through or along equipment. Provide valved taps every 50 feet in general pipe rack runs.

Provide service air and water hose stations within 100 feet of all areas around the plant that may require air or water for maintenance or wash-down. Route 1-inch minimum lines to the hose stations. Terminate all hose stations with a quarter turn ball valve and "Chicago type" hose coupling.

Provide plugs or caps in all valved connections open to the atmosphere.

All lines filled with a liquid that could freeze under extended shutdowns which are not freeze protected as required in the Insulation section of this specification, shall be designed and provided with sufficient drains and vent valves to allow fully draining as a means of freeze protection. Drains and vents on such piping shall be designed to be accessible from grade or elevated platforms.

All above ground piping shall be metallic unless specifically approved by Owner.

Piping shall be carried on overhead pipe-ways, sleeper-ways, or trenches. Space for electrical and instrument conduit runs shall be provided on the pipe-ways and sleeper-ways as required. Space for electrical and instrument conduit runs shall be segregated to eliminate electrical interference.

Underground metallic piping shall be provided with corrosion protection based on the recommendation of a certified corrosion engineer for the piping material and measured soil resistivity. Underground piping shall be routed following designated corridors, rather than the shortest path. The firewater loop piping and potable water piping shall normally be routed underground.

Condensate, feedwater, and steam lines shall not be installed below grade.

### 5.3.2 Piping Classes

Contractor shall furnish specifications identifying the piping classes for the major systems. The class description shall include service description, pressure/temperature rating values and materials, descriptions, types, and ASTM specifications for fittings, flanges, branch connections, welding, gaskets, bolting, pipe, and bends.

A general listing of minimum piping materials that shall be used for each service is provided in the following table. To the extent that there is any conflict between the piping materials listed below and any other provision of this specification, except code, the piping materials shall have priority. Contractor is responsible for ensuring the materials specified are suitable for the intended service and shall substitute higher quality materials where required to meet the intended service life of the plant. All substitutions shall be approved by Owner.

<b>TABLE 5-3 PIPING MATERIALS</b>		
<b><u>Service</u></b>	<b><u>Media</u></b>	<b><u>Material</u></b>
Ammonia	Aqueous Ammonia	ASTM Type 316 SS
Boiler Blowdown	Treated Water	ASTM A53 Gr. B or A106 Gr. B or Alloy Piping as required for the application, ERW or SMLS
Chemical Treatment Dilute Acid Tubing	Sulfuric Acid	ASTM B468 UNS N08020, Alloy 20, Fully Annealed, SMLS with a hardness of Rb95 or less Fittings to be flareless type.
Circulating Water	Water	Below Grade: AWWA C301 and C304 Concrete Cylinder Pipe with Interior Coating Suitable for the Intended Service or AWWA C200 Steel Pipe with interior coating suitable for the intended service or ASTM D1248, D3350, & F714, HDPE per ASTM D3350 class 345434C. Above Grade: ASTM A53 Gr.B ERW or SMLS, A106 Gr. B ERW or SMLS, A283C, A516 Grade 70, or A285 Grade C with Coal Tar Epoxy on the inside.
Closed Cooling Water	Treated Water	Above Grade: ASTM A53 Gr. B or A106 Gr. B., ERW or SMLS Below Grade: ASTM D1248, D3350, & F714, HDPE per ASTM D3350 class 345434C.
Compressed Air Piping	Air	ASTM A312-TP304, Fully Annealed, Stainless Steel or ASTM B88 Hard Tempered (Soft annealed if used with ferrule tube fittings), Type K
Compressed Air (Instrument tubing)	Air	ASTM A213, Type 316, Fully Annealed, SMLS, Stainless Steel with a hardness of Rb80 or less or ASTM B75, Soft Annealed, SMLS, Copper

		Fittings to be flareless type
Condensate	Water	ASTM A106 Gr.B, SMLS.
Demineralized Water	Water	Above Grade: ASTM A312-TP304L, seamless, Fully Annealed, Stainless Steel Below Grade: ASTM D1248, D3350, F714, & HDPE per ASTM D3350 class 345434C
Drains – Cold (Below Grade)	Water	ASTM D1248, D3350, & F714, HDPE per ASTM D3350 class 345434C
Drains – Hot (Below Grade)	Water	Ductile Iron, AWWA C151, Soil Pipe, Mechanical Joints
Feedwater	Water	ASTM A106 Gr.B, SMLS.
Firewater	Water	Above Grade: ASTM A53 Gr. B or A106 Gr. B, ERW or SMLS, Galvanized Below Grade: ASTM D1248, D3350, & F714 High Density Polyethylene (HDPE) per ASTM D3350 class 345434C and Factory Mutual Approved for 200 psig W.W.P.
Lube Oil (Supply Piping)	Oil	ASTM A312 Gr.B, TP 304 H, SMLS, Stainless Steel
Natural Gas	Natural Gas	<u>Upstream of Filter/Separator</u> ASTM A106 Gr.B, SMLS <u>Downstream of Filter/Separator</u> ASTM A312-TP 304 L, SMLS, Stainless Steel
Potable Water	Water	Above Grade: ASTM A53 Gr. A or B or , ASTM B88 type K seamless. Below Grade: ASTM D1248, D3350, & F714, HDPE per ASTM D3350 class 345434C.
Raw Water	Water	Above Grade: ASTM A53 Gr. B or A106 Gr. B ERW or SMLS, 2-inch diameter and less to be Galvanized. Below Grade: ASTM D1248, D3350, & F714, HDPE per ASTM D3350 class 345434C.
RO Water	Water	Above Grade: ASTM A312-TP304L, seamless, Fully Annealed, Stainless Steel Below Grade: ASTM D1248, D3350, F714, HDPE per ASTM D3350 class 345434C.
Sample Piping/Tubing & General Chemical Piping/Tubing	Steam & Condensate Samples and	ASTM A213, Type 316, Fully Annealed, SMLS, Stainless Steel with a hardness of Rb80 or less (Samples over 800F shall

	General Chemicals	use Type 316H stainless steel tubing) Below Grade: ASTM D1248, D3350, & F714, HDPE per ASTM D3350 class 345434C.
Sanitary Waste	Sanitary Waste	Cast Iron Soil Pipe, Hub & Spigot or ASTM D1248, D3350, & F714, HDPE per ASTM D3350 class 345434C.
Softened Water	Water	Above Grade: ASTM A53 Gr. B or A106 Gr. B ERW or SMLS, 2-inch diameter and less to be Galvanized. Below Grade: ASTM D1248, D3350, & F714, HDPE per ASTM D3350 class 345434C.
Steam	Steam	Seamless Steel or Seamless Alloy Piping as Required for the Application
Waste Water	Waste Water	Above Grade: ASTM A53 Gr. B or A106 Gr. B, ERW or SMLS Below Grade: ASTM D1248, D3350, & F714, HDPE per ASTM D3350 class 345434C.

All tubing shall be free of scratches and suitable for bending and flaring. ASTM B88 copper tubing used with ferrule type connections shall not be embossed on the exterior. Tubing wall thickness shall meet or exceed the recommendations of Swagelock for use with Swagelock tube fittings.

Carbon steel lines 2 inches and smaller shall be schedule 80 minimum. For 2 inch and smaller alloy steel lines, minimum wall thickness shall be calculated based on design conditions.

Design pressure of piping systems shall be a minimum 20 psig above the maximum pressure anticipated during operation or 50 psig, whichever is greater. Where piping is directly or indirectly connected to the discharge of a pump, the maximum operating pressure shall be the maximum pump shut-off head. Design temperature of piping systems shall be a minimum of 15°F above and below the maximum and minimum temperatures anticipated during operation.

Include a 1/16-inch corrosion allowance on all carbon steel piping.

Piping 2 ½ inch NPS and larger shall utilize butt-welded construction. Firewater piping does not require butt-welded construction.

Ammonia piping shall be of welded construction. Connections to equipment and instruments may be threaded. All other piping shall be of welded construction, except small bore service water and potable water. Victaulic couplings are allowed on above grade fire protection systems.

All above ground piping shall be metallic unless specifically approved by Owner.

### **5.3.3 Line List**

During the project design phase Contractor shall prepare a piping line list showing line number, originating P&ID number, points of origin (i.e. line or equipment), points of destination, classification, line size, insulation thickness and materials, flowing media, operating pressure, operating temperature.

### **5.3.4 Clearances**

Good design practice shall be followed to assure proper clearance between piping equipment and passageways for operation and maintenance. Proper space shall be provided to service control valves and their operators. Special attention shall be given to provide access for cranes or other equipment handling devices. Clearances shall be provided as specified in the Access and Clearances section of this Specification.

Provide sufficient clearance between lines to permit access for repair or removal. Clearance between pipe and flanges, fittings, or insulation on adjacent pipe shall not be less than 6 inches. Where pipe is insulated, clearance shall be between insulation and flanges, fitting or insulation on adjacent piping.

### **5.3.5 Piping Stress Analysis**

As a minimum, all piping 2-1/2 inches and larger connecting to rotating equipment and/or having a design temperature of 250°F or greater shall be subjected to the piping analysis.

Piping analyses shall be performed either by computer or by simplified methods as allowed by piping codes and shall consider:

1. Thermal expansion
2. Deadweight and hydrotest loads
3. Steam hammer and relief valve thrust
4. Equipment manufacturer's allowable nozzle loads
5. Wind load for piping routed outside
6. Seismic loads and detailing requirements

The piping flexibility analysis shall be based on a system's design conditions of pressure and temperature encountered during startup, normal operation, or shutdown. To these operating design conditions, industry accepted conservative margins (safety factors) of temperature and pressure shall be added. Also, the analysis shall consider the maximum temperature differential. The effect of installation temperature and solar temperatures shall be considered in determining the maximum temperature differential.

Computer analysis shall be performed on all piping covered by ASME Boiler and Pressure Vessel Code, Section I and all condensate, feedwater, and steam piping 2-1/2 inches and larger. Other pipe stress analysis methods may be used for the analysis of other plant piping systems. The following industry accepted methods can be used: Grinnel, Tube-Turn, Kellogg, Spielvogel, Flex-Anal Charts, Guided Cantilever.



The piping loads at the equipment nozzles shall be limited to equipment manufacturer's allowable loads. If equipment manufacturer's allowable loads are not available, the piping loads shall be limited to the following levels: Cast connections - 50 pounds per nominal inch, forged connections - 200 pounds per nominal inch (not to exceed 2000 pounds). The actual calculated load shall be forwarded to the manufacturer for their concurrence.

### **5.3.6 Pipe Bending**

Pipe bends may be used. Carbon steel pipe may be hot bent or cold bent. Field bending of stainless steel pipe shall not be allowed. Bending of carbon steel below 1,300°F is considered cold bending. For hot bending pipe shall be heated to a temperature not exceeding 2,000°F. No hot bending or forming shall be performed at temperatures below 1,650°F. Bending radius shall not be less than five times nominal pipe size unless approved by Owner. Wall thickness of pipe and metallurgy after bending must meet applicable code requirements for specified design conditions. Final minimum wall thickness after bending shall comply with minimum wall thickness required by the applicable codes.

### **5.3.7 Pipe Sleeves**

All pipes passing through walls, floors, roofs, decking, and grating shall have sleeves provided. Sleeves shall be sized and have clearances to allow for packing and sealant installation. Sleeves shall be 18-gauge carbon steel except that sleeves 8 inch and larger shall have ¼ inch minimum wall thickness. Where pipe movement is anticipated or pipe size is subject to change, larger sleeves shall be used. All floor sleeves shall be anchored with lugs or similar devices. The annular space between the pipe and sleeve at wall and floor penetrations shall be packed with fiberglass. Where penetrations are in walls or floors designed for fire separation, special sealants and packings designed specifically for the application and to meet the fire separation requirements as required by the applicable NFPA codes shall be used. Firestop materials shall be in accordance with applicable ASTM or UL standards.

### **5.3.8 Dissimilar Metal Joints**

In all cases (except for air systems) when a piping connection is made between steel and aluminum or copper the mating surfaces shall be electrically isolated. For 2 ½ inch and larger piping, flanges shall be used and the flanged joint shall be made using an electrically non-conducting gasket and flange bolts fitted with plastic ferrules and plastic washers under the bolt heads. Two-inch and smaller connections may be made using flanges, as stated above, or with dielectric type couplings, bushings or unions.

Electrically isolated joints shall also be employed at all points where above ground piping meets piping from below ground.

### **5.3.9 Equipment for Plant Start-up**

Temporary piping and supports shall be furnished for chemically cleaning the HRSG and steam blowing. Piping, specifically fabricated for the project, that connects to the steam turbine valves shall be turned over to Owner for future use. This is not intended to require Contractor to fabricate and turn over any temporary piping that could be provided by renting.

Silencers shall be used during all steam blowing operations to minimize noise. Silencers are not required to be turned over to Owner.

All pumps shall be furnished with start-up strainers and with the fittings for their easy installation and removal.

#### **5.3.10 Sewer and Underground Piping**

Contractor shall ensure the entire plant site is adequately and properly drained. Paved plant operating area shall be sloped from high points and catch basins shall be provided for storm runoff where required.

Vessel and other equipment drains shall interconnect with the plant drainage system and not the storm system. Sewers and drain lines shall run in the general direction of collection or disposal without sharp angles or turns. The minimum size of underground drain lines shall be 4 inches. Buried steel lines shall be coated and wrapped for corrosion protection. Cathodic protection and/or coating and wrapping shall be provided for all underground piping, vessels and metallic equipment in contact with the earth. Cathodic protection methods shall be recommended by a Corrosion Engineer after reviewing the Geotechnical data for the site and shall be approved by Owner.

#### **5.3.11 Vents and Drains and Manholes**

All piping high points shall be vented and all piping low points shall have drains. The minimum vent and drain line size shall be ½-inch or larger as required. Manholes shall be provided as required by final design.

#### **5.3.12 Root Valves**

Root valves shall be of standard gate or globe pattern, mounted with stem upright or horizontal, unless otherwise specified. Root valves shall be positioned as follows:

1. Gate valves – stem upright (preferred), or as nearly upright as conditions permit, but in no case below the horizontal.
2. Y-pattern globe valves – stem upright (preferred), or as nearly upright as conditions permit, but in no case below the horizontal.
3. Special valves – including remotely operated solenoid and control valves, shall be mounted in accordance with their manufacturers' recommendations.
4. No valve shall be mounted with the stem below the horizontal centerline.

Root valves shall be double blocked in services greater than 600 psig or 800°F.

#### **5.3.13 Root Connections**

Root connections on horizontal or sloping lines shall not be located below the horizontal center of the line. The following rules shall be observed:

1. Root connections for service on steam and condensable vapors or wet gas shall be taken from the top or side of the pipe or from any point between the top and the side.
2. Root connections for service on liquids shall be taken only from the side of the pipe, with the root nipple horizontal.
3. Root connections for service on dry gases shall be taken from the top of the pipe.
4. All root nipples shall be as short as possible, in standard lengths. Room shall be allowed for free manual operation of the valve without the hand or fingers coming into contact with the surface of the pipe or its insulation. Root nipples, longer than 6 inches end-to-end shall not be used.

Welded thermowells shall be installed according to code requirements. Threaded thermowells shall be installed in threaded bosses. Thermowells and piping in which thermowells are installed shall be designed specifically for the application to prevent cycling and fatigue of the thermowells.

#### **5.3.14 Fabrication Requirements**

Fabrication shall be in accordance with the specified Codes. All piping materials shall be in accordance with good engineering practice and all piping and fittings shall be new and clean.

Fabrication tolerances shall be in accordance with good engineering practice. Tolerances shall cover general dimensions such as face to face, end to end, or end to center. Tolerances shall not be cumulative.

Weld reinforcements shall be held to a minimum and edges shall merge smoothly with the basic metal without undercutting. All repairs shall be made with matching weld metal and edges shall merge smoothly with the basic metal with no undercutting. The welding procedure shall be established by Contractor and submitted for review to Owner and shall be in conformance with applicable codes.

#### **5.3.15 Shop Cleaning**

Cleaning of surfaces, which are not to be painted or coated shall be done according to the supplier's best recommended practice, and it shall achieve the cleanliness level described by the acceptance criteria and the specific requirements described below.

Parts of subassemblies that may have crevices or inaccessible surfaces after assembly shall be cleaned as well as practicable, prior to assembly.

All cleaning operations shall be conducted so that stainless steel and nickel alloys are not contaminated with lead, copper, mercury and/or other low melting point metal; chlorides, sulfur, halogens, as well as ferrous steel materials.

Abrasive blasting may be used on raw, unmachined casting, forging or plate only.

### **5.3.16 Inspection**

Contractor shall be responsible for inspection of all fabricated piping material. Owner reserves the right to inspect fabrication at any time. Contractor shall maintain qualified personnel to inspect shop and field fabrication for material specifications, dimensional accuracy, fabrication techniques, and quality.

### **5.3.17 Protection for Shipment and Construction**

All flange faces, machined surfaces and threads shall be clean and shall be protected from damage during shipment. Flange faces and machined surfaces shall be protected with wood or metal covers. Couplings and threads shall be protected by steel pipe plugs or by plastic protectors. Pipe shall be cleaned and supplied with end caps prior to shipping. All protective coverings and end caps shall be maintained in place until the component is erected and open ends or faces replaced between installation shifts.

### **5.3.18 Welding**

All welding, welding procedure qualification and welder qualification shall be in accordance with the specified Codes. Contractor shall qualify all welders. Each welding procedure shall include a welding procedure qualification test report.

Welding shall not be performed on materials that are below a minimum temperature of 50°F (at the weld-affected zone) and surfaces to be welded shall be free of moisture prior to welding.

The maximum interpass temperature when welding austenitic stainless steel shall be 350°F.

Field butt weld ends on shop fabricated piping and components shall have end preparations dimensioned in accordance with ANSI B31.1 and B16.25. All welding end preparations made in the field shall be in accordance with the requirements stated above.

Integral attachments welded to piping shall be of the same P-number material groups as the piping material. Attachments, which are shown on the piping Drawing or which require post-weld heat treatment shall be welded in the piping fabricator's shop. All other integral attachments shall be welded in the field. Integral attachment on piping having design temperatures of 600°F or higher shall be attached by full penetration welds except riser clamp shear lugs which may be attached with fillet welds.

Backing rings shall not be used in any service.

All root passes on butt-welded steam, boiler feedwater, condensate, demineralizer make-up water, and fuel gas shall be made using the gas tungsten arc (TIG) process.

### **5.3.19 Field Installation**

Piping shall be assembled and installed in accordance with the applicable sections of the specified Codes. Contractor shall take special care that the installed piping is free and clear of all foreign materials, construction debris, etc. All welds shall be clean and free of burrs and slag.

Installation and orientation of all gauge glasses, live controllers, thermometers, thermocouples, pressure gauges, etc. shall be arranged for convenience of operation and ease of maintenance.

Pipe insulation shoes shall be adjusted so that they are centered over pipe supports in the hot position after the line is completely installed and brought into operation.

### **5.3.20 Pipe Supports, Guides, Restraints and Anchors**

The following requirements shall govern the installation of pipe supports for large bore and small bore piping systems.

#### **5.3.20.1 General Requirements**

All pipe supports shall be installed in accordance with MSS-SP58, MSS-SP69, ANSI B31.1 and B31.3, AISC and AWS D1.1.

Pipe supports shall be constructed of ASTM A36, ASTM A992, Grade 50, or ASTM A500 carbon steel, or alloy steel components as required by pipe materials or process conditions.

Surfaces to be welded and surfaces up to 1 inch from the edge of the weld shall be clean and free from oil, rust, scale, paint and other deleterious materials.

Installation of the permanent hangers at the time of pipe installation is required. Hangers shall be installed so that their nameplates are visible and accessible.

All hanger components to be installed indoors shall be given a prime coat of inorganic zinc primer. All hanger components to be installed outdoors shall be galvanized with the exception of lugs and clips welded directly to pipes or structural members.

The spacing of hangers and supports for steel piping shall not exceed the values recommended by ANSI B31.1.

All hanger components shall support the piping in the normal operating position and during hydrostatic test, shall allow for the expected expansion or contraction except where anchored and guided, and shall not cause excessive stresses in the piping or excessive loads on the connected equipment.

Standard stock or production parts shall be used where possible. The recommended load ratings and limitations in Manufacturer's hanger catalogs shall not be exceeded.

For critical systems accurate weight balance and thermal movement calculations shall be made to determine the required supporting force of each hanger and the limits imposed upon each equipment connection. The weight balance for all hangers shall include the weight of the pipe, fittings, valves, the medium transported, the insulation used and the suspended portion of hanger assemblies and pipe attachments. Spring hanger assemblies shall be designed to support the piping under normal operating conditions. All hangers and components, however, shall be designed to adequately supporting the piping system during hydrostatic test.

Supports shall not be attached to other piping systems to support the loads, except that supports for cold piping are allowed to hang from other cold piping. Hangers shall not be attached to flange, valve or equipment bolts or to equipment. Hangers shall be a minimum of 6 inches away (in either hot or cold position) from any flange and shop or field pipe welds.

Adjustable type pipe supports shall be used at all pump suction and discharges.

Supports installed on concrete slabs or pads shall be installed on a minimum of 1 inch of grout. Use shims to bring supports to elevation. Jack nuts shall not be used.

#### 5.3.20.2 Attachments to Piping

Integral attachments shall be used only where non-integral attachments are impractical at Owner's discretion. Where necessary, symmetrically loaded clamps with equally spaced shear lugs welded to the pipe shall be used. Localized stresses, induced by external forces into the pipe wall, shall be analyzed in combination with all existing pipe stresses to ensure that total stress levels are within code allowable values.

Steel used in integral attachments shall be compatible with the piping materials.

Non-integral attachments to piping shall be of design and materials suitable for the entire range of operating temperatures of the piping system.

Clamps used as the attachment to a piping components in a strut assembly shall have a minimum spring rating equal or greater than five times the strut spring rating.

Clevises, turnbuckles, and eye nuts shall be forged steel. Eye rods shall be welded type.

Pipe clamps above 750°F shall be alloy steel in accordance with the Power Piping Code. Protection saddles 750°F and higher shall be alloy steel in accordance with ANSI/ASME B31.1.

For insulated lines at 750°F and below, pipe clamp MSS Type 3 or clevis hanger MSS Type 1 with an MSS Type 39 insulation protection saddle shall be used. All voids in the pipe covering protection saddles shall be filled with insulation. Supports on insulated piping shall not penetrate the insulation lagging. For lines with no insulation, pipe clamp MSS Type 3 or 4 or clevis hanger, MSS Type 1 may be used. Riser clamp MSS Type 8 shall be used on all risers.

For lines that are heat-traced and lines which have an operating temperature below 70°F, the use of clamps or attachments in direct contact with the pipe shall be minimized to the greatest extent possible. Except for unusual situations that require attachments in direct contact with the pipe, the attachments or clamps shall be outside the thermal insulation. For horizontal pipe, the thermal insulation shall be protected by means of pipe covering protection saddles, MSS Type 39, and pipe clamps or clevis hangers sized to fit on the insulation OD. All voids in the pipe covering protection saddles shall be filled with insulation.

#### 5.3.20.3 Attachments to Structure

Reduction of the effective strength of any structural member shall not be permitted. Structural attachments to steel shall be designed to support the maximum calculated loads. For attachments to the supporting steel on hangers for pipe sizes 2 ½ inches and larger, beam attachments MSS Type 22 shall be used within the limitations of loads. For piping 2 inches in diameter and less, where relatively small movements are expected and where hangers are normally not engineered, MSS Type 23 may be used. Where sliding supports or other integral base attachments are supported on a concrete floor an anchored or fixed steel base shall be provided as a sliding surface.

Structural attachments should be made to steel whenever possible, whether to structural steel or to steel embedment plates or inserts in structural concrete. When necessary to use drilled-in-place bolts in concrete, only wedge type anchor bolts such as HILTI Kwik-Bolts, or equal shall be used, and the connection shall be carefully designed using the allowable loads including the effect of combined tension and shear loads, spacing and embedment depths.

No attachments should be made to anything but structures.

Anchors, supports, restraints and guides shall be designed to prevent the transmission of temperatures in excess of 300°F to building steel and 150°F to concrete. This determination may be made by using a reduction factor of 100°F/inch from the outside surface of the pipe for all parts in direct contact with or welded to the pipe.

#### 5.3.20.4 Spacing

Support points shall be selected on the basis of proper location and spacing for optimum load distribution and weight balance, taking into consideration the available building structure and load distribution from which hangers can be suspended.

The spacing of hangers and supports for steel shall not exceed the values given in ANSI B31.1 unless formal pipe stress analysis in accordance with B31.1 is performed for the specific application(s). The above maximum spacing figures are applicable to straight piping runs. Additional supports shall be provided for concentrated loads such as valves, strainers or other in-line items. At changes in piping direction, supports shall be located at, or immediately adjacent to, the change in direction to the greatest extent feasible, and the spacing to the next support beyond the change in direction shall be appropriately less than the maximum spacing of supports permitted for straight piping runs.

Vertical pipe should be supported directly with riser type hangers rather than having the weight of the riser supported by adjoining horizontal pipe.

The maximum support spacing recommendations of the nonmetallic or nonferrous pipe manufacturer shall not be exceeded.

#### 5.3.20.5 Pipe Support Identification

Contractor shall submit the pipe support identification system to Owner for its approval. The numbering system shall include the system code.

#### 5.3.20.6 Anchors, Restraints and Sliding Supports

Anchors, guides and restraints shall be capable of supporting the pipe and resisting dead loads plus any expansion or contraction thrusts that may be imposed by the piping.

Anchors required for expansion joints shall withstand the longitudinal pressure force plus the joint-spring force and sliding friction force. The longitudinal pressure force shall be calculated as the product of the hydrostatic test pressure and the maximum internal transverse area of the joint. Guides for expansion joints shall direct piping movement into the joint within the joint manufacturer's allowable lateral and angular misalignment limits.

Sliding supports and guides shall be designed to withstand the induced friction force in addition to other loads on the support. Dry lubricant surfaces (i.e. Teflon or UHMW) may be used to reduce the friction force. Preformed graphite or carbon shall not be used.

Corners and edges of metal slides and guides in sliding supports shall be rounded or chamfered and guide parts shall be designed with sufficient length so that binding within the necessary clearance will not occur.

#### 5.3.20.7 Hanger Rods

Hanger rods shall be sized in accordance with ANSI B31.1. Hanger rod diameters shall be 3/8 inches minimum on 2 inch and smaller pipe and 1/2 inch minimum on piping 2 1/2 inch and larger and shall be compatible with the other component parts of the hanger assembly and subjected to tension stresses only. Where horizontal movement is anticipated, the rod shall be fitted with eyes, links or swivels to permit unrestrained swinging of the rod. Un-welded eye rods shall not be used. Where anticipated piping movement would cause hanger rods to be more than four degrees out of plumb, the hangers shall be offset in the erected position to provide vertical alignment when the piping system is in operation. Hanger rod lengths shall be calculated to provide for at least plus or minus 3 inches of rod adjustment subsequent to hanger erection.

Maximum length of rods shall be 20 feet. Minimum rod length shall be 15 inches for each inch of horizontal movement.

#### 5.3.20.8 Variable Spring Hangers

All variable spring hangers shall be selected for operation at or about the mid-load range. The length of spring and the spring scale shall be selected so that variation in the supported load due to temperature differences does not exceed 25 percent of the dead load; otherwise, constant support hangers shall be used.

The working range of variable spring hangers shall account for all load movements as well as for thermal movement. A minimum of 1/2 inch additional travel beyond the maximum and minimum values at the working range shall be provided after final field adjustments.

Variable spring hangers shall be of the enclosed helical, pre-compressed type with the end coils ground flat and square with the spring axis. Travel stops shall be factory installed so that the piston cap is set at the "cold" position. The travel stop shall be easily identified and removable but shall act as a "rigid" hanger during erection and



hydrostatic testing. To avoid misplacement of a travel stop, it shall be attached to the spring unit by means of a cotter pin and chain or equivalent. Variable spring hangers shall be calibrated by a dynamometer and the load affixed to the housing. The unit shall then be adjusted to the proper ambient position to suit the travel it is to accommodate and the position plates locked. The locked unit shall be capable of supporting at least two times the normal operating load. When the loads induced by hydrostatic testing exceeds the spring capability, temporary supports shall be installed. Each variable spring hanger shall have a travel and load scale plate, red and white markers to indicate the design hot and cold positions, respectively, and a travel indicator. The red and white markers and the travel indicator shall be easily visible at a distance of not less than 30 feet and visible from the ground or platform. The hanger type, mark numbers and calibrated load shall be die-stamped on each hanger nameplate.

#### 5.3.20.9 Adjustment and Locking Devices

All supports shall have screw adjustments accessible and workable when fully loaded. Threaded members shall have a true and complete depth of thread. Nuts, clevis's, sleeves, turnbuckles, etc., shall have their full length of thread in complete service while in use and the amount of male thread available for adjustment plainly visible; sight holes shall be provided for visibility in parts where necessary. Eight pitch series threads will be permitted only when the Contractor furnishes both mating parts. All bolts on hangers shall have double nuts. Hanger rods shall have a locking nut on each end of the turnbuckle.

#### 5.3.20.10 Inspection

When the piping is being put into service, the hangers shall be inspected by Contractor's qualified inspectors to insure the pipe is moving as intended and is not causing the hangers to deflect against travel stops or exceed load or travel scale.

When the system has reached maximum normal operating temperature, the spring hangers shall be inspected and, if necessary, adjusted to the hot or calibrated position indicated on the hanger. If a hanger is deflected to its stop, it shall be adjusted immediately so that it will carry load on the spring and not on the stop. In making such adjustments, care shall be exercised to avoid adjustments which will result in a hanger deflecting against stops or off-the-load or travel scale as the pipe cools during a shutdown. If such a condition is unavoidable, the hanger must be replaced with one of proper size.

#### **5.3.21 Painting**

Un-insulated piping, above grade, structural and miscellaneous carbon surfaces shall be shop blasted, primed and finish coated in accordance with Section 7. Surfaces shall also be finish painted and color coded with colors selected by Owner.

Carbon steel piping which is installed underground shall be coated with one of the following:

1. Prime with Type B primer and coat with coal tar enamel and non-asbestos felt wraps per AWWA C203. Finish with one coat of water resistant whitewash.
2. 12-inch & smaller: Coat with mill applied polyethylene plastic coating, Entec or X-Tru-Coat, or approved equal.

3. Shop applied tape wrap. Tab shall consist of butyl-based adhesive with polyethylene backing (similar to Polyken 930, Protecto Wrap 310, or Tapecoat CT).

Consult the services of a corrosion engineer to recommend further corrosion protection based upon the soils condition. Submit the corrosion engineer's recommendations to Owner for information and acceptance of the recommendations. Provide cathodic protection for underground piping as recommended by the corrosion engineer and as approved by Owner.

Lines shall be labeled with flowing media and flow direction at strategic locations to provide service identification. Labels shall be in accordance with applicable ANSI standards. All labeling of piping shall be provided by Contractor.

### **5.3.22 Testing**

Hydrostatic testing shall be performed after piping is completely installed. Test pressure shall be in accordance with the specified Codes. Care shall be exercised by Contractor to protect vessels, equipment and instrumentation which can be damaged during pipe pressure testing through the use of slip blinds or other suitable means. Contractor shall provide all necessary equipment to perform test including, but not limited to, pumps, heaters and temporary valves and fittings.

## **5.4 VALVES**

This portion details the technical requirements for furnishing, delivering, and installing butterfly, globe, gage, check, plug and ball valves. Contractor will complete valve data sheets and specify all valves in accordance with the requirements of this section.

### **5.4.1 General Requirements**

All hand operated valves 2-inch and smaller for throttling service shall be globe valves unless service requires other specific types.

All control valves shall have a bypass valve and isolation block valves. Bypasses installed around liquid service equipment shall use globe type.

Isolation valves shall be provided on all piping connections to equipment.

Isolation valves for pump suction and discharges shall be located in the larger piping sections.

Wherever practical, valves shall be located to be accessible from grade or elevated platforms. Valves shall be provided with a minimum of one handle length or handwheel diameter clearance between handle or handwheel in all positions and the nearest obstruction.

Install valves with stems vertical, wherever practical. Where not practical, stems shall be horizontal or above.

Install valves with indicators visible from accessways or elevated platforms wherever possible.

All instruments and gauges that are not in-line, except flow switches and temperature elements, shall be supplied with root valves for isolation during maintenance.

#### **5.4.2 Valve List**

During the project design phase Contractor shall prepare a valve list showing system code, valve tag number, valve type, originating P&ID number, pressure class, size, flowing media, operating pressure, and operating temperature.

A unique valve tagging system shall be used to tag all valves, with the exception of instrument root valves. The valve tagging system shall be referenced when identifying the specific valves in all documents, including but not limited to P&IDs, valve lists, Operating Procedures, and data sheets.

#### **5.4.3 Valve Materials**

All valves and valve materials shall be chosen as to be suitable for the intended service fluid, temperatures, pressure and flows. Good engineering judgment shall be used at all times. The yoke or intervening structural member(s) between the valve and operator shall be of an ASTM material.

A graphite packing system (e.g., Grafoil ribbon pack with corrosion inhibitor, using end rings of braided graphite filament) is preferred. Alternate asbestos-free packing systems compatible with the intended service shall be submitted to Owner for approval.

#### **5.4.4 Valve Shop Painting**

Corrosion-resistant valve surfaces shall not be painted or treated with a rust preventative.

Exposed external ferrous steel surfaces of the valve assembly shall be painted with one coat of the manufacturer's standard primer, except for machined working surfaces or adjusting nuts, bolts or studs which shall be coated with a rust preventative, suitable for providing up to 1 year corrosion protection under outdoor storage conditions.

#### **5.4.5 Lubricant Materials**

Replacement lubricants, where required, shall be in accordance with manufacturer's requirements.

#### **5.4.6 Design Requirements**

Butterfly valve design shall be to, and meet the requirements of, MSS SP67, Type I, for tight shutoff.

Steel gate, globe and check valves 2 ½ inch and larger shall be in accordance with ANSI B16.10 and B16.34.

Steel gate, globe and check valves 2 inches and smaller shall have their pressure ratings in accordance with ANSI B16.34 and shall be of forged material.

Gate and globe valves shall have bolted packing gland and a fixed backseat.

Bronze valves shall be designed, manufactured and inspected in accordance with MSS-SP80.

The stem finish in the area that will contact the packing shall be 32 rms or better. The stuffing box wall shall have a 125 rms or better finish. When required, seals shall be provided to retain grease and keep dirt and moisture out of bearings. Alemite lubricating fittings shall be furnished to lubricate bearings, yoke nuts or bushings.

All forgings shall be clean and free from unacceptable defects. Repair of unacceptable defects is not allowed on forgings.

Valves of the same size, type, material and pressure/temperature rating shall have interchangeable parts in order to reduce spare parts inventory.

Ball valves shall be in accordance with MSS SP72, and ANSI B31.8.

Ball, plug and butterfly valves shall have blowout proof stems whose retention shall comply with ANSI B16.34, Paragraph 6.5.

All ball valves shall be of top entry type so that the ball and seals can be replaced in the body without removing the valve from piping during maintenance. However, alternate types will be considered provided the design does not require cutting welds to remove the ball and seals. Submit alternates for Owner's approval.

Plug valves shall be designed to the requirements of the API-6D. Plug valves shall be wrench or gear-operated, and of the tapered plug, self-lubricating sleeve, or reinforced seat type.

Flanged and weld-end valves shall conform to the face-to-face and end-to-end dimensions of ANSI B16.10 for each respective pressure class.

The valve and operator assemblies shall be designed and assembled so critical parts cannot become disengaged due to vibration and/or assembly orientation. Particular attention should be given to drive keys to assure that they are locked or "captured" by means other than press fits or the use of adhesives.

#### **5.4.7 Valve Operators**

Select valve operator and install valve to allow operation of valve without interference with adjacent piping or equipment without valve operator disassembly.

Provide gear operators for ball, plug, and butterfly valves 6 inches and larger.

If smaller valves require more than 60 lb of force applied to the manufacturer's standard lever, Owner shall be advised as to the force required to operate and options available (e.g., lever length) so it can be determined whether a gear actuation is required.

Gate and globe valves shall be provided with the manufacturer's standard operator or handwheel for seating the valve.

Valves with gear operators shall be provided with a protective pipe and/or pipe plug on the operator, as appropriate, to protect the stem/stem nut from dirt, debris, etc. Operating valves installed at an elevation of more than 6 feet 9 inches between the bottom of the handwheel and grade or an elevated platform shall be furnished with a chain operator for operation from grade or elevated platforms. Install chain operators such that chain hangs within 2 feet of the operating level and can be "tied off" on a nearby structure so as to keep the chain out of the operating aisles.

Block valves used only for isolation in shut downs or repairs that are accessible by portable ladder need only be supplied with chain operators if installed at an elevation of more than fifteen feet between the bottom of the handwheel and grade.

Operating valves installed with handwheels under platforms shall be supplied with extensions for operation above the platform.

Supply quarter turn valves with locking devices on the handles.

Provide valve handle extensions of extended bonnets on valves installed in pipelines designated to be insulated. Handle extensions shall be suitable to provide a minimum of 2 inches clearance between the handle and the outside of the insulation jacket.

## **5.5 INSULATION AND JACKETING**

### **5.5.1 General Requirements**

This criteria covers the requirements for the selection and application of insulation systems for plant equipment and piping. Contractor shall be responsible for determining the economical insulation thickness and selecting the appropriate insulation material.

Provide illustrations and instructions for field installation of insulation for piping, valves, vessels, and equipment that is not pre-insulated by the supplier.

Provide removable insulation and jacketing sections at all flanged joints in insulated piping. Install removable sections to allow entire flange studs to be removed from either side of joint.

Insulation on valves shall be extended to include the valve bonnet.

#### **5.5.1.1 Insulation**

Minimum insulation thickness shall be 1 inch.

Provide an insulation specification thickness table and specification summary sheet indicating materials, manufacturer, material thermal properties, and application requirements for each insulation system proposed. Table shall indicate required heat conservation insulation thickness for each nominal size of piping and duct and for equipment for each 100°F temperature increment in the range of 200°F to 1100°F. Table shall also include insulation thickness for burn protection for each NPS and equipment components in the same temperature range and for anti-sweat insulation for each NPS and for equipment.

All outdoor piping shall be insulated and freeze protected OR self draining unless approved by Owner. Use removable insulated jackets on control valves and large isolation valves. Freeze protection should be extended at least 12" below the frost line for the site. Insulation and jacketing shall be repaired after construction.

All piping, with a nominal size 1/2" and smaller, filled with a liquid that could freeze under normal operation or during a shutdown of up to 3 days in length at any ambient conditions within the design range of the site shall be heat traced and insulated as required to prevent freezing under such conditions. Such lines shall include, but not be limited to, instrument tubing, chemical tubing, sample analysis piping, boiler trim piping, boiler and steam line drain piping, and service water piping to utility stations. All heat traced tubing shall be integrally heat trace tubing / heat tracing bundles.

Provide heat conservation insulation on all piping and equipment operating above 200°F for which heat loss is not desirable. Insulation thickness shall be determined by an economic analysis of the cost vs. energy savings for the ambient conditions. In no case shall the surface temperature of any insulated lines be allowed to exceed 140°F throughout the operating range of the plant. Components requiring insulation shall include, but not be limited to, the following:

1. All steam piping
2. Boiler feedwater pumps and piping
3. Condensate piping (after condensate enters the preheaters)
4. Natural gas pre-heater gas side piping downstream of the heater
5. Feedwater piping feeding and returning from natural gas pre-heater
6. HRSG steam drums and trim
7. HRSG casing including all transitions
8. All other lines with an operating temperature above 140°F.

Provide anti-sweat insulation on piping installed in areas where the ambient dew point could be below the surface temperature of the piping at any conditions within the operating range of the plant.

Provide personnel protection insulation on all surfaces operating above 140°F or the OSHA limit, whichever is lower, which are accessible from grade, ladders, or elevated platforms. Personnel protection insulation shall limit the surface temperature to a maximum of 140°F at any ambient condition or as required by OSHA (whichever is more restrictive). Personnel protection insulation shall extend to a level of 7 feet (minimum) above grade or platforms and 3 feet (minimum) beyond any handrail.

Insulation materials shall have a flame spread rating of 25 or less, when tested in accordance with ASTM standard E84. Where installed inside building, insulation shall have a smoke density of 50 or less, when tested in accordance with ASTM standard E84. Select insulation materials to be suitable for the intended service in accordance with the National Insulation Association standards. Wherever practical, use calcium silicate insulation with a minimum density of 10-lb/cu ft on hot piping systems. Where temperatures exceed the allowable limits of calcium silicate, use ceramic fiber insulation. Use elastomeric rubber, polyethylene, or polyisocyanurate foam insulation on cold service piping for anti-sweat applications. Anti-sweat applications shall include a continuous, unbroken, vapor seal. Outdoor anti-sweat insulation not provided with a jacket, shall be painted in accordance with insulation manufacturer's recommendations.

Use cellular glass insulation on all hot piping requiring insulation, which is installed in an area prone to flooding (either due to rainfall or from process upsets).

Insulation installed on stainless steel shall be limited in chloride content and shall meet the latest revision of military specification, Mil-1-24244B. Certification test is not required; however, manufacturer shall guarantee that insulation meets this standard.

Provide removable blanket insulation on all manways, removable covers, control valves, automated valves, engineered valves, and instrumentation installed in insulated piping systems. Transmitters and other remote mounted instrument shall be supplied with O-Brien, pre-fabricated, insulated instrument enclosures with quick opening latches. Removable blankets shall be 1-inch minimum thickness for temperatures to 250°F, 2-inch minimum thickness from 250°F to 500°F and 3 inch minimum thickness above 500°F. Use stainless steel speed lacing hooks or stainless steel D-rings with fabric straps.

Insulation materials containing asbestos are not permitted.

Insulation application including mastics and coatings shall be in accordance with insulation manufacturer's recommendations and the National Insulation Association standards.

Insulation installed in areas subject to foot traffic shall be designed to prevent collapse of the insulation.

Provide insulation support rings on vertical piping 6 inches and larger with spans greater than 10 foot. Maximum spacing between support rings shall be 10 feet.

Acoustic insulation shall be designed and applied to piping and equipment where required to meet the noise limits specified in Section 1.

#### 5.5.1.2 Jacketing

Provide jacketing systems on all insulated equipment and piping, except those insulated with elastomeric rubber or polyethylene. Install jacketing to prevent the entry of moisture. Jacketing materials shall be as follows:

Equipment:	0.036 inch thick (minimum), non-reflective, aluminum with vapor barrier
Piping and valves:	0.020 inch thick (minimum), non-reflective, aluminum with vapor barrier

Use non-reflective aluminum bands with wing seals to hold jacketing in place.

Seal all penetrations in jacketing with mastic cement and weather tight flashing.

Seal all breaks in insulation that would be exposed upon removal of flange insulation, equipment insulation, instrument insulation, or removable jacket insulation. Seal end caps using aluminum flashing and mastic.

Apply jacketing in accordance with insulation and jacketing manufacturer's installation instructions.



## **SECTION 6.0**

### **CIVIL SCOPE**

#### **6.1 GENERAL REQUIREMENTS**

This section covers the minimum scope and quality for the plant civil design and construction.

Contractor is responsible to inspect the site, obtain all necessary site data, perform all required additional Geotechnical investigations and determine all site data for the design and construction of the power plant. This shall include determination of local code requirements for seismic, and wind design loads. It is Contractor's sole responsibility to ensure the building foundations and site work comply with all federal, state and local code and permit requirements and all industry codes and standards.

All waste material removed from the site shall be properly disposed of by Contractor.

The scope shall include, but not be limited to the following:

1. All subgrade facilities and preparation
2. Site drainage both during construction and permanent
3. Construction stormwater disposal
4. Site grading including cut and fill with suitable material as required to the finished plant grade. Contractor shall provide any additional fill and backfill materials necessary
5. Construction of all foundations and structures
6. Roads (permanent and temporary construction)
7. Site Security (permanent and temporary fencing including gates)
8. Off-site & On-Site Road Improvements (if required to transport or receive equipment or if required as a result of construction work.

The Project design shall take into account existing site conditions with respect to soil characteristics, grading, and drainage. Contractor shall be responsible for all grading, drainage, roadways, fencing, and parking areas.

### 6.1.1 Units

All design dimensions and design calculations shall be in British (United States Customary) units. The following are preferred units for drawings and calculations:

Drawings	Scale (Min)
Structural Steel Framing Plans	1/8 in = 1 ft
Structural Elevations	1/8 in = 1 ft.
Structural Steel Sections & Details	Appropriate Scale
T/G Pedestal Plan	3/16 in = 1'-0"
Sections	1/2 in = 1'-0" or as Appropriate
Architectural Plans	1/8 in = 1 ft.
Architectural Elevations	1/8 in = 1 ft.
Architectural Sections & Details	Appropriate Scale
Site Plans	1" = 20' or, 1" = 30' or, 1" = 60'
Site Sections & Details	Appropriate Scale

### 6.1.2 Geotechnical

See Section 2.1 "Site Requirements" of this Specification. Preliminary Geotechnical Study is attached in Appendix G. Contractor shall provide supplemental geotechnical investigations as required.

## 6.2 SITE PREPARATION AND MAINTENANCE

Contractor is responsible for all site preparation, backfill, and excavation to finished site grades. Contractor shall implement measures to control settlement within the site. The geotechnical investigation performed by Paul C. Rizzo Associates for Block One of the Lake Side Power Project recommends extensive site work to control settlement due to the amount of fill to be added to site. Contractor shall be responsible for performing any and all studies, investigations, or other work necessary to provide sufficient and appropriate information for site improvement considerations. Owner will furnish one permanent survey monuments on property. Contractor is responsible to maintain and install additional monuments as required for construction use.

### 6.2.1 Site Preparation

Contractor shall design and specify site grading to include all trench excavation for underground pipe, including circulating water pipe, and duct banks. The site shall be properly leveled with no construction debris or dirt piles. Consideration shall be given to drainage to ensure no low-lying areas are left, which would accumulate water. Installation of site construction utilities shall be planned and constructed by Contractor. Owner will approve the locations.

### 6.2.2 Drainage

The working areas of the site shall be well drained during and after construction. The site drainage plan and discharge of drainage from the site shall conform to federal, state

and local laws and regulations and the project permits. All drainage shall be away from the buildings.

### **6.2.3 Erosion**

Contractor shall prepare a Storm Water Pollution Prevention Plan (SWPPP) for their construction activities in Planning Areas. SWPPP shall generally include the requirements and controls in the draft SWPPP submitted as part of the Application for Certification for the project site grading. Contractor shall be responsible for maintaining the stormwater controls and best management practices including the indicated stormwater detention pond in accordance with the SWPPP. Contractor shall provide for sediment and erosion control during and after construction in accordance with project permits and local and state laws and regulations. Best management practices such as check dams and sedimentation basins shall be used during construction to minimize erosion. Drainage facilities shall be designed and constructed in a manner to minimize erosion.

### **6.2.4 Debris**

All construction-related debris and unsuitable material shall become the immediate property of Contractor and shall be removed from the premises and disposed of off-site by Contractor.

### **6.2.5 Road Maintenance**

All temporary access roadways used by Contractor shall be maintained in serviceable condition. Contractor shall keep the surfaces of those roadways free from spills, mounds, depressions, and obstructions, which might present a hazard or annoyance to traffic.

### **6.2.6 Signs and Barricades**

All signs and barricades shall be provided and maintained by Contractor and shall be in accordance with jurisdictional regulations for accident prevention.

### **6.2.7 Dust Control**

Contractor shall be responsible for dust control at the Site. Contractor shall prevent the spread of dust during its operations. Contractor shall moisten all surfaces with water to reduce the risk of dust becoming a nuisance to the public and neighbors. Contractor shall furnish all labor and equipment necessary for dust control including tank trucks and hoses to apply Contractor furnished water. Contractor shall conform to all requirements of the Applicable Permits.

### **6.2.8 Open Burning**

Onsite open burning will not be permitted.

### **6.2.9 Excavation, Filling, and Backfilling**

Excavated material may be used for fill and backfill when suitable for given application as determined by geotechnical investigation. To the extent possible, backfill and subgrade fill will utilize excavated materials. Contractor shall provide additional fill and backfill materials as required. Under-slab and bedding material, topsoil and other

materials from offsite borrow areas shall be the responsibility of Contractor. Site dewatering during construction is the responsibility of Contractor.

Waste material shall be disposed of in accordance with local ordinances and practices, or regulations.

Fill characteristics and compaction requirements shall be determined by Contractor's geotechnical investigation and report recommendations.

Temporary sheet piling, if required for construction or trenching, may be either steel or timber and will be removed upon completion of construction. If piling is to be left in place after construction, only sheet piling will be permitted.

#### **6.2.10 Site Grading**

Grades shall be established to minimize the amount of earthwork required to construct the facilities. All areas disturbed during construction shall be graded to a smooth surface and (covered with appropriate material as conditions require). Finish grading will be performed to conform to the finished design elevations for surface drainage and to prepare the areas to receive the specified surface finishes.

### **6.3 SITE IMPROVEMENTS**

Paving and fencing improvements shall be in accordance with the site plan and detail drawings included in the Appendices. Final design shall be shown in detail on Contractor's final plot plan. Paving design criteria shall be:

1. Subgrades shall be constructed of material with CBR of 4 or better, if available.
2. Design life shall be 30 years.
3. The construction period will produce 70 to 80 percent of the wheel loads for the design life.
4. Structures supporting pavement shall be designed to support HS20 standard highway loads.
5. Pavement design shall be in accordance with AASHTO or other Owner approved procedures.

#### **6.3.1 Storm Water Drainage System**

A storm water drainage system shall be used to collect all rainwater from the site that is not potentially contaminated by oil and or other chemicals (non-active areas). Building roof drains will drain into this system. The storm water drainage system shall drain into the site stormwater detention pond, which will then drain to the local drainage system. Provide suitable facilities and access for sampling of the storm water discharging from the stormwater detention pond.

All rain water collected from active areas that can be contaminated by oil shall be routed through an oil/water separator as described in the Mechanical Scope Section before being combined with the sanitary sewer flow from the site and routed to the sewer tie-in point as indicated on General Arrangement Drawings included in Appendix C.

### **6.3.2 Sanitary System**

The sanitary sewer system shall tie-in to the existing local sanitary sewer system as indicated on General Arrangement Drawings included in Appendix C.

### **6.3.3 Fencing and Gates**

Security fences, where applicable, are to be constructed 7-foot high standard galvanized chain link fence with 3 strands of barbed wire. Gates, as required for vehicular access, will be a minimum of 2 sections, each 10 feet wide.

### **6.3.4 Surfacing**

All general plant areas that do not require paving or landscaping shall be surfaced with a minimum 6 inch thickness of compacted aggregate. The areas within the substation fence, will be finished with crushed stone or gravel by Others.

### **6.3.5 Manholes**

Manholes are to be provided as required by final storm water and sanitary sewer system design.

### **6.3.6 Duct Banks**

Underground banks of power and instrument conduit shall be encased in concrete. Encasements shall be reinforced when ducts pass under roadways or traffic areas. Top of ductbanks shall be color marked.

### **6.3.7 Landscaping**

Disturbed areas that do not contain foundations, paving, or other surfacing shall be stabilized and protected from erosion by topsoil and seed or other erosion control measures. Seed mixture shall be suitable for local conditions..

### **6.3.8 Roads and Parking**

Subgrade preparation and compaction shall be in accordance with sound geotechnical engineering practice and as recommended by Contractor's geotechnical investigation and report. Paved roads and surfaces shall be paved as described below unless, state or local codes and standards specify more stringent requirements.

Roadways, parking areas, and the equipment laydown areas shall be paved as described below.

Roadways and paved areas shall be designed in accordance with AASHTO or owner approved equal. Paving may be either reinforced concrete or asphalt concrete and shall be designed based on the value of the modulus of subgrade reaction (k) determined for the site by Contractor's geotechnical investigation and report.

In general, plant roads shall have a minimum one way lane width of 12 feet, and a two-way total width of 20 feet. The plant access road shall have two 12.5 foot lanes. Minimum radius of the inside edge of pavement shall be 45 feet. All roads shall have a 2% slope from the crown with shoulders sloped at 2%. All other paved areas shall slope a minimum of 1% to drains.

### 6.3.8.1 Roads

Roads on-site shall conform to the following:

<b>Description</b>	<b>No. Lanes</b>	<b>Lane Width</b>	<b>Shoulder Width</b>	<b>Surface</b>
Access Road	2	12.5 ft	2 ft.	Paved
Plant Island Perimeter	2	10 ft.	2 -	Paved
Building Driveways	1	Width of Door Plus 2'	-	Paved
Equipment Access	1	12 ft.	-	Paved

1. Applicable Specifications:

Utah Department of Transportation's Standard Specifications for Road and Bridge Construction.

2. Subgrade Preparation:

Subgrade shall be proof rolled with five (5) passes of a 10-ton vibratory roller (minimum), or as required by additional geotechnical analysis.

3. Pavement

Road pavement materials shall be in accordance with the State of Utah Department of Transportation's Standard Specifications for Road and Bridge Construction and final geotechnical investigation and report. Pavement design shall be in accordance with AASHTO or Owner-approved equal and the following criteria:

Design Traffic Number, DTN = 50

Design Vehicle = HS20-44

Subgrades shall be constructed of material with CBR of 4 or better, if available.

Design Life = 20 years

The construction period will produce 70 to 80 percent of the wheel loads for the design life.

4. Horizontal and Vertical Curves

Horizontal and vertical curves shall meet the Federal Highway Administration, AASHTO.

The inside edge of paved surfaces at intersections shall have a minimum radius of 40 feet inside the plant.

Vertical curves shall be as long as practicable.

#### 6.3.8.2 Parking Areas

Parking spaces for vehicles shall be provided for plant personnel and visitors. Parking shall meet requirements for the physically handicapped. Car stops, parking lines, and lighting shall be provided. Parking spaces quantity and layout shall be as approved by Owner. Contractor shall provide additional parking stalls as directed by Owner.

Provision shall be made within the fenced areas for parking in accordance with the local zoning ordinances.

#### 6.3.8.3 Bollards

Above ground piping, valves, fire hydrants, and accessories adjacent to traffic areas shall be protected with 6" diameter steel pipe guard posts painted yellow, minimum height of 42" above ground and 36" below ground. Post shall be set in 12" minimum diameter hole filled with concrete. Post shall also be filled with concrete with a domed shape on top.

#### **6.3.9 Oil/Water Separation**

Work areas, equipment areas, transformer secondary containment areas, unloading areas, roads, and other areas subject to spills, will drain to an oil/water separator(s) system as specified in Section 5.2.26.2 and designed to prevent oil-contaminated runoff from leaving the site or contaminating the site. Other areas will be designed to drain out through the site drainage system.

#### **6.3.10 Plant Material Unloading Areas**

Areas where plant consumables are unloaded (i.e. ammonia, oil, chemicals) shall have a concrete pad and be designed to provide containment of leaks and spills in accordance with all applicable regulations but not less than 110% of the single largest compartment of the tanker truck.

## **SECTION 7.0**

### **STRUCTURAL AND ARCHITECTURAL SCOPE**

This section covers the minimum scope and quality standards for the plant structural and architectural facilities.

#### **7.1 MATERIALS**

##### **7.1.1 Steel**

Design of structural and miscellaneous steel shall be in accordance with the American Institute of Steel Construction (AISC) "Manual of Steel Construction, Allowable Stress Design (ASD), 9<sup>th</sup> Edition". Design of structural and miscellaneous steel shall also be in accordance with National Electrical Manufacturers Association (NEMA) "SG6" and "TT1", and the International Building Code (IBC).

Materials for structural steel and miscellaneous steel shall conform to the requirements of the American Society for Testing and Materials (ASTM) multi-certification A36/A572, Grade 50 material or ASTM A992, Grade 50 Material.

Metal decking shall comply with SDI "Design Manual for Floor Decks and Roof Decks."

Structural steel grating shall be welded and hot-dipped galvanized and shall conform to Federal Specification RR-G-661, type I. Grating shall be banded at edges and openings with bars of the same size as the bearing bars. One size grating shall be used throughout the Project. Grating for exterior use shall be serrated.

Minimum stair tread width shall be uniform for full length of stairs. Rise and run of stairs shall be in accordance with local building codes, state requirements, the International Building Code (IBC), and OSHA requirements.

High strength bolts, nuts, and washers shall conform to ASTM A325, ASTM A563, and ASTM F436 respectively. Additionally, in connections of galvanized steel members, high strength bolts, nuts, and washers shall be galvanized in accordance with ASTM A153 except that a 1.65-ounce coating shall be provided.

Anchor bolts and anchor bolt assemblies shall be galvanized and shall conform to ASTM A449 or F1554, Grade 36. Anchor bolt sleeves shall conform to ASTM A501.

Steel pipe for handrail shall conform to ASTM A53, Type E or S, Grade B.

Filler metal for welding shall conform to the requirements of AWS D1.1.

Galvanizing, as specified herein, shall conform to the requirements of ASTM A123 or ASTM A153, as applicable.

##### **7.1.2 Concrete**

Design of structural concrete shall be in accordance with the American Concrete Institute (ACI) - "Building Code Requirements for Reinforced Concrete," ACI 318, latest edition.



An independent testing laboratory shall be retained by the Contractor to perform acceptance sampling and testing of the concrete in the field. Sampling and testing shall be in accordance with ACI 301 and all applicable ASTM procedures. Make at least one strength test for each 100 cu yd, or fraction thereof, of each concrete mix placed in any single day. Determine the concrete slump for each strength test sample and whenever consistency of the concrete appears to vary. Determine air content of each strength test sample of air entrained concrete. Record the ambient temperature and the concrete temperature for each sample. Test results shall be provided to Owner for records.

Minimum concrete strength classes for various structures shall be as follows:

<b>Item</b>	<b>Minimum Compressive Strength,(psi) (at 28 Days)</b>
Subgrade leveling slab	2,000
All other construction	3,000
Major equipment/structures where required	4,000

Reinforcing bars shall be deformed bars conforming to ASTM A615, Grade 60. Welded wire fabric shall conform to ASTM A185.

Cement shall be Portland cement conforming to ASTM C 150. Cement type, (Type I, Type II, or Type V) shall be selected to comply with ACI 318 recommendations in Section 4.3, regarding sulfate exposure. All concrete in contact with circulating water shall utilize Type V cement.

The minimum cement content for 4000 psi mixes shall be 564 lbs per cubic yard and the maximum water cement ratio shall be 0.45, unless noted otherwise. Concrete shall be homogeneous, readily placeable, uniformly workable and finishable, and shall be proportioned to conform to ACI 211.1. Mix designs shall be approved based on ACI 318 requirements.

Aggregates for normal weight concrete shall conform to ASTM C33.

Provide a housekeeping pad under all pumps and heat exchangers. Pad shall extend a minimum of 6 inches above grade or slab, whichever is higher.

Provide a minimum of 1 inch of grout under all equipment, support structures, platform supports, pipe supports and other structural supports that are mounted on concrete foundations or concrete slabs. Apply grout in accordance with grout manufacturer's instructions.

All concrete trucks shall be rinsed out on site. Rinse material shall be properly disposed of offsite.

## **7.2 STRUCTURAL LOADING**

### **7.2.1 Dead Loads**

Dead loads shall include all vertical loads due to weight of permanent structural and nonstructural components, including permanent hung loads.

### **7.2.2 Live Loads**

Live loads shall be in accordance with local codes, the Utah Uniform Building Standard Act Rules (R156-56), the 2003 International Building Code, and ASCE Standard American Society of Civil Engineers Minimum Design Loads for Building and other Structures, ANSI/ASCE 7(latest edition), unless local governing code is more severe.

### **7.2.3 Wind Loads**

Wind loads shall be in accordance with the Utah Uniform Building Standard Act Rules (R156-56) which includes the 2003 International Building Code and ASCE-7. Basic wind speed shall be 90 miles per hour.

### **7.2.4 Seismic**

Seismic loads shall be in accordance with local codes, the Utah Uniform Building Standard Act Rules (R156-56) which includes the 2003 international Building Code and ASCE-7. Seismic acceleration parameters shall be in accordance with the IBC as follows:

$$SDs = 0.74g$$

$$SD1 = 0.38 g$$

The soil profile type shall be determined by the Contractor based on the results of a subsurface investigation, which shall be performed by the Contractor.

### **7.2.5 Thermal Loads**

Buildings and structures shall be designed for forces and/or movements resulting from a change in temperature. Induced thermal loads (i.e., thermal loads induced by equipment operating temperatures) shall be considered in design of applicable structural elements.

### **7.2.6 Crane Loads**

Crane loads shall be in accordance with the 1989 AISC Specification for Structural Steel Buildings – Allowable Stress Design (ASD) and plastic Design and Code of Standard Practice for Steel Buildings and Bridges. Additional requirements for the turbine room crane are listed under Section 7.5, BUILDINGS/STRUCTURES.

Each boiler feed pump will be provided with a permanent monorail. All other remaining equipment shall be situated so that maintenance can be carried out using mobile cranes provided by Owner.

### **7.2.7 Vehicle Loads**

Design loading, for areas accessible to trucks, shall be (AASHTO) HS20-44.

Floors in buildings accessible to a forklift truck shall be designed for the forklift truck wheel loads.

### **7.2.8 Pipe and Equipment Anchor Loads**

Supporting structures shall be adequate to resist all pipe and equipment anchor loadings under all design conditions, including seismic.

## **7.3 STRUCTURAL FOUNDATIONS**

Type and depth of foundations required shall be as recommended by Contractor's Geotechnical Engineer based on the existing subsurface conditions and geotechnical studies. Site preparation for foundation construction, such as pre-loading or installation of vertical drains, shall be in accordance with the Contractor's Geotechnical Engineer's recommendations.

Foundations supporting rotating machinery shall be checked for resonant frequency and isolated from other foundations using expansion joints.

The combustion turbine generator foundations shall be isolated from surrounding building foundation mats and shall be designed such that no adverse dynamic response or settlement occurs. The foundation shall satisfy the settlement, deflection, and dynamic response criteria supplied by the equipment manufacturer.

Gas turbine foundations and steam turbine foundations shall include foundation embedments for anchoring and aligning the equipment. Gas turbine foundations shall include fixators to facilitate alignments.

Foundations for hydraulic equipment and oil-filled transformers shall include concrete slabs and curbs for containment of the largest spill plus fire water or precipitation from the 10-year recurrence interval storm. Provide piping and pumps with drainage to the plant oily water separator.

All loose materials shall be removed from excavation bottoms. Unsatisfactory foundation subgrade material shall be removed and replaced with compacted structural fill material or with 2000 psi concrete. .

### **7.3.1 Turbine Foundations & Containment**

The Steam turbine foundations shall be designed in accordance with manufacturer's recommendations. In addition, guidelines outlined in ASCE technical publication "Design of Large Steam Turbine Generator Foundations" shall be considered during the design of the steam turbine foundation

Steam turbine lube oil console area and underdeck area below the bearings of the steam turbine shall be provided with containment and drainage to the plant oily water separator.

The steam turbine generator (STG) foundation shall be designed for the following:

1. Static loading per STG Manufacturer's loading diagram.
2. Vertical impact load as specified by the STG Manufacturer.
3. Area live load of 0.5 kip per square foot on all periphery beams at operating floor, 0.3 kip per square foot at intermediate floor level, and 0.3 kip per square foot on grating areas.
4. Torque, vacuum, horizontal impact, thermal and alignment loads per STG Manufacturer's load diagrams.
5. Deflection shall be limited to values specified by STG Manufacturer under loading conditions as specified.

### **7.3.2 Buildings and Equipment Foundation**

Building and equipment foundations shall be of reinforced concrete including all formwork, rebar, waterstop, and other concrete accessories necessary for a complete installation.

### **7.3.3 Tank Foundation**

Tank foundations shall be either reinforced concrete slabs or reinforced concrete ring wall foundations with a compacted sand bottom within the ring walls.

Provide secondary containment area around lube oil tanks and pumps with drainage to the plant oily water separator.

### **7.3.4 Transformer Foundation and Containment**

Transformers shall be provided with oil containment and drainage to the plant oily water separator. Drain lines shall be provided with normally closed manual drain valves.

Electrical transformer foundations shall include fire walls as recommended by NFPA and the Owner's Insurance.

## **7.4 ARCHITECTURAL**

The architectural design of the buildings, sound attenuation, and all associated facilities shall seek to optimize functional, aesthetic, and economic considerations; and minimize the visual impact on the surrounding area. Safety and construction requirements shall be in accordance with the requirements of applicable state and local codes.

All exterior lagging, painted surfaces, and galvanized surfaces shall be a non-reflective finish.

### 7.4.1 Siding

Exterior siding of other buildings shall be insulated metal wall panels. Exterior siding for all air-conditioned areas shall be insulated.

Wall panels shall be designed to withstand the specified wind loading with practical/economical support girt spacing.

Exterior face of metal wall panels shall be finished with polyvinylidene fluoride finish with 70% Kynar or Hylar resin. Interior liner panels shall be finished with manufacturer's standard primer.

Owner to approve exterior and interior color selection.

### 7.4.2 Roofing

Roofing shall be designed to withstand specified wind loading, including appropriate uplift. Roofing will be standing seam sloped metal.

Roofing shall be pitched not less than 1 ¼ inch per foot and shall drain to a roof drain system. Pitch shall be governed by local codes and standards.

### 7.4.3 Interior Construction Materials

In general, architectural finishes for each area shall be per the following table:

Room Name	Floor	Wall	Ceiling
Steam Turbine Generator Building	mc	mwlp	Ex
DCS Room	rcp**	Gbp	Sap
Electrical Equipment Room	mc	Gbp	Ex
Battery Room	cmc	Gbp	Ex
I & E Shop	vct	Gbp	Sap
Maintenance Shop	mc	Cmup/mwlp	Ex
Process Areas	mc	Cmup/mwlp	Ex
CEMS Shelters	MFG Std	MFG Std	MFG Std
Water Treatment Area	mc	mwlp	ex
Chemical Labs	mc	cmup/mwlp	Ex

Floor Finishes:

1. cmc – sealed, cast-in-place concrete coated with coating resistant to battery acid attack
2. mc - sealed, cast-in-place concrete
3. vct – vinyl composition tile
4. cft - unglazed ceramic tile
5. rcp – special raised composite panel floor
  - A. Specialty coatings shall be applied in areas subject to acid or chemical spills
  - B. \*\* Vinyl tile in Control Room shall be static dissipative type. Owner will provide manufacturer's name, style, color and contact information.)

Wall Finishes:

1. gbp – epoxy painted gypsum board on metal studs. Where applicable, metal stud partitions shall be insulated to reduce sound transmission.
2. mwlp – full height metal wall liner panel at pre-engineered building exterior walls
3. cmup - filled, painted concrete masonry
4. cwt - glazed ceramic tile over masonry or gypsum board

Ceiling Finishes:

1. sap – lay-in grid, grid type, suspended acoustical panel (use moisture resistant type in lockers and toilet areas)
2. ex - exposed to structure

Interior surfaces and walls shall meet fire rating requirements of the Applicable Codes and of the Fire Marshall.

**7.4.4 Platforms**

Platform, other than those within the scope of major equipment suppliers, shall be provided by the EPC Contractor. All platforms shall be designed and supplied with handrail and toe-plate in accordance with OSHA standards. Ladders and stairs shall be in accordance with state and local building codes, the IBC, and OSHA standards. See Mechanical Scope, General Requirements, for the types of platforms required.

Provide self-closing, OSHA approved safety gates on all platform ladder openings. Chain type safety gates shall not be used.

**7.4.5 Stairs**

Stair construction shall be open riser where permitted by code. Stair treads shall receive cast abrasive or bent checker plate nosings.

Cross brace all stringers where the horizontal run exceeds 12 feet to provide lateral stability.

Fasten stair tread to stringer with a minimum of two 3/8-inch bolts.

#### **7.4.6 Handrail**

Railings and posts shall be 1-1/2-inch diameter steel pipe with welded joints and ground smooth. Handrails provided for all platforms and equipment access shall be aesthetically consistent. Handrailing shall be in accordance with Applicable Codes. The rail system shall be capable of resisting a 200 pound load applied to the top rail.

#### **7.4.7 Windows, Window Walls, Entrance Doors, and Louvers**

Windows and Window Walls – Window and window wall systems shall be anodized finished aluminum unitized framing systems with tinted, factory-fabricated, double pane insulating low "E" glass. Color of anodizing shall be selected to match the plant color system. Windows to areas which have possible explosive equipment failures shall be wire safety type.

1. Louvers – Louvers shall be drainable, fixed-blade, manual or gravity operating, weatherproof-type louvers, and shall include bird screens and be finished in a color to match adjacent wall panels.
2. Exterior Doors
  - A. Personnel Doors – Exterior doors shall be flush panel type insulated steel doors with vision panels in pressed steel frames with weather stripping, weatherproof saddles, closures, and kick plates.
  - B. Coiling Steel Doors – Coiling steel doors shall be insulated standard type, motor operated, with manual chain-operated override, hood baffle, weather stripping, and bottom seal.
3. Interior Doors – With the exception of fire rated and coiling steel doors, all other interior doors shall be 1-3/4-inch thick, hollow metal flush panel-type in pressed steel frames. Vision panels shall be provided where appropriate. Fire rated interior doors shall have windows with wired safety glass.

All permanent fixtures in the plant lab, including but not limited to, sink, exhaust hood, cabinets with countertop, wall cabinets, and the like will be supplied and installed by Contractor.

Administrative and office areas will be furnished by Owner.

#### **7.4.8 Painting**

In general, all exterior and interior surfaces, except items furnished in manufacturers finish or finish coat, shall be painted, including:

1. All structural steel, un-insulated piping, and miscellaneous steel (except surfaces to be encased by concrete).
2. Surfaces of all ferrous metal.
3. All gypsum board. Gypsum board shall be painted in a semi-gloss acrylic enamel latex coating system.

4. Concrete unit masonry shall be painted with an acrylic latex system, unless a special coating system is specified.
5. All Owner furnished equipment shall be finish painted by Contractor.

Stainless steel and galvanized steel shall not be painted.

Protective coating surfaces shall be non-reflective.

Surface preparation and coating system application shall be in accordance with coating manufacturer's recommendations unless more strict requirements are specified.

### Protective Coatings

Component	Surface Prep.	Primer	Finish Coat
Interior Structural Steel Building Framing, including Framing for Hangers and Equipment	SSPC-SP6	Organic Zinc/epoxy, 3 to 4 mils DFT or Galvanized	Acrylic Polyurethane, 3 to 5 mils DFT or Galvanized
Misc. Steel, Interior or exterior (handrail, stair stringers, ladders, toe plate)	SSPC-SP6	Organic Zinc/epoxy, 3 to 4 mils DFT or Galvanized	Acrylic Polyurethane, 3 to 5 mils DFT or Galvanized
Exterior Structural Supports & Framing for Equipment	SSPC-SP6	Organic Zinc/epoxy, 3 to 4 mils DFT or Galvanized	Acrylic Polyurethane, 3 to 5 mils DFT or Galvanized
Platform Grating, Stair Grating, Interior and Exterior	Per the American Hot Dip Galvanizers Assoc. Recommendations	Hot Dipped Galvanized	
Interior Above Grade Uninsulated Piping (not requiring color coding)	SSPC-SP6	High Build Epoxy Primer or Galvanized	None
Interior Above Grade Uninsulated Piping (requiring color coding)	SSPC-SP6	High Build Epoxy Primer or Galvanized	None



Exterior Above Grade Uninsulated Piping	SSPC-SP6	Inorganic Zinc Rich Primer	Polyurethane, 3 to 5 mills
Exterior and Interior Insulated Piping	None	None	None
Equipment, Motors, Valves, Instruments, and other manufactured components	Manufacturer's Standard	Manufacturer's Standard	Manufacturer's Standard
Stainless Steel, Galvanized, or Nonferrous pipe or Materials	None	None	None
Stacks and other hot surfaces	SSPC-SP6	Inorganic Zinc Rich ethyl silicate, 2 to 3 mils DFT	Hi-temp silicon, 3 to 5 mills

#### 7.4.8.1 Surface Preparation

The exterior surface of structural and miscellaneous steel, and tanks shall be abrasive blasted as a minimum in accordance with the Steel Structures Painting Council, SSPC-SP6 Commercial Blast, or SSPC-SP5, White Metal Blast for submerged items.

Tank interiors to be lined shall receive an abrasive blast in accordance with SSPC-SP5, White Metal Blast, with a 3.0 mils maximum anchor pattern.

Small miscellaneous field fabrications shall be given not less than SSPCSP3, Power Tool Cleaning.

All masonry surfaces to be coated shall receive a light brush-off blast or an acid etch prior to coating.

Unprimed piping shall be field-cleaned to a minimum of SSPC-SP3, Power Tool Cleaning.

#### 7.4.8.2 Prime Protective Coating for Steel

All structural and miscellaneous steel shall be primed within 8 hours after the surface preparation in accordance with the applicable coating system noted above. Primer shall be in accordance with the coating system specification sheets. Open web joists may be primed with a red iron oxide primer.

#### 7.4.8.3 Finish Coating

Structural and miscellaneous steel shall be finish coated as specified in the above Protective Coatings Table.

Above grade piping shall be color-coded to coordinate piping service where required by Applicable Codes. As a minimum, the following services shall be color coded in accordance with ANSI recommendations: Ammonia, Fire Protection, Hydrogen and Fuel Gas.

Before painter's finish work is begun, the surface to be painted shall be carefully inspected to assure that they are in proper condition to receive the finish coating. Surfaces, which are in poor condition, so that a proper finish cannot be produced, shall receive such special treatment or additional coats as necessary to produce a smooth, durable, satisfactory finish.

## 7.5 BUILDINGS / STRUCTURES

### 7.5.1 Minimum requirements

Drawings showing floor plans, equipment arrangements, and other building and architectural features shall be submitted by the Contractor for Owner's review, comments, and approval. Building framing may be Pre-Engineered or designed of standard rolled shapes.

Include lifting devices such as cranes, hoists, trolleys, and monorails in all buildings and structures at locations above all equipment weighing more than 200 lbs. Capacity of the lifting device shall be at least 15 percent above the maximum load to be lifted. Coordinate locations with the equipment layouts.

Design all building roofs, platforms, and structures for a minimum collateral load of 15 psf, in addition to the Code required and Specified live loads. Increase the minimum collateral load in routing corridors for piping, electrical conduit, and cable tray, and determine the design collateral load by consideration of actual weights and by calculations.

Buildings shall be provided as follows:

Building	Min number of external doors / windows	Minimum Size	Special Notes
Steam Turbine Generator Building	Exit doors in accordance with Building Code. Minimum of two roll-up doors.	Per the Site Plan and in accordance with specification.	One of the roll-up doors shall be sized to allow removal of the largest piece of equipment.
Water Treatment Equipment Building	2 roll-up doors, 2 personnel doors, no windows.	As required for access of enclosed equipment.	
CEMS Shelters	1 door	8 ft x 10 ft (if 1 per CTG) or 10 ft x 12 ft (if 1 per 2 CTGs).	

Building	Min number of external doors / windows	Minimum Size	Special Notes
Other Buildings	Per Building Code requirements.	As required for access of equipment.	

### 7.5.2 Steam Turbine Generator Building

Column bases shall be designed as pinned.

The turbine room roof design shall utilize horizontal bracing.

Floor and roof live loads shall be as follows

1. Turbine room roof 30 psf
2. Operating floor, turbine room area 500 psf
3. Operating floor, other areas 250 psf
4. Ground floor 300 psf plus H2O loading

Building footprint shall be adequately sized to allow laydown of all turbine generator components during maintenance, refurbishment, or overhaul.

### 7.5.3 Other Structures

Contractor shall provide sun shade covers for all CO2 and bulk gas storage systems. Provide a minimum of 20 ft wide shed roof structure to provide covering for equipment and maintenance materials.

Contractor shall provide all platforms and ladders around the CT including access to the top of the CTG enclosure to facilitate operations activities during water washing.

Provide a prefabricated air-conditioned enclosure for housing the steam cycle sample panel. The enclosure shall include heating and ventilation as required.

### 7.5.4 HRSG Equipment Enclosure

Provide steel frame equipment enclosure with weather-tight metal siding and roof deck at the top to the two HRSG Units. Include doors with hardware, ventilation, and interior lighting.

### 7.6 Turbine Room Crane

The Turbine Room Crane shall be capable of handling the heaviest piece of disassembly of the steam turbine. Determine the required crane capacity by consideration of the maximum weight to be lifted during overhaul of the actual equipment furnished. Estimated crane capacities are as follows:

1. 75-ton minimum capacity main hook
2. 25-ton minimum auxiliary hook

Operation shall be by remote radio control and by control pendant suspended from trolley. Include a platform with stair or ladder to provide access to the crane bridge service platform from the Turbine Operating Floor.

## **SECTION 8.0**

### **ELECTRICAL SCOPE**

#### **8.1 GENERAL REQUIREMENTS**

This section covers the minimum scope and quality standards for the major electrical equipment, systems, and interfaces with other plant systems and facilities and with off-Site facilities. Contractor shall provide all material and labor for the engineering, design, procurement, installation, construction, startup, inspection, and testing of all electrical systems specified herein and necessary for a complete, functional power generating facility, and in conformance with generally accepted utility practices for generating facilities.

The conceptual design is shown on one line diagram SKE-1 that are included in Appendix E. Contractor shall develop a detailed plant design based on Owner's conceptual design. Alternative designs may be acceptable if they meet the functional requirements of this specification. Any changes in plant arrangement or design must be approved by Owner. Arrangement and design of the auxiliary power system equipment shall provide for unobstructed vertical clearance on the access road between units for bringing in cranes and other heavy equipment for maintenance.

The design and specification of all work shall be in accordance with all applicable laws and regulations of the Federal government and the State of Utah, and applicable local codes and ordinances. A listing of the codes and industry standards to be used in design and construction is found in Section 3.0. All equipment furnished under these specifications shall conform to applicable standards of IEEE, NEMA and ANSI. All materials and devices shall be in accordance with the applicable requirement of the Federal "Occupational Safety and Health Standards". The latest editions of the referenced codes and standards shall apply. Equipment ratings and capacities are generally referenced to 40° C maximum ambient and less than 3300 feet. Contractor shall revise ratings accordingly for equipment and materials where required for Project maximum ambient conditions and elevation.

Other recognized standards may be utilized when required in Contractor's opinion and when not in conflict with the standards listed in Section 3.0. Contractor shall notify and obtain Owner approval prior to any changes.

##### **8.1.1 Plant System Studies**

Contractor shall perform a set of system studies to demonstrate the adequacy of the proposed electrical system design, including AC and DC distribution systems, by performing the following studies as a minimum. The design and construction of the electrical systems shall reflect the findings and conclusions of these studies. Prior to starting studies, provide Owner with cases to be analyzed. Owner will identify other cases if required to meet the criteria established in the following. These system studies shall be subject to review and comment by Owner.

1. Load flow and voltage regulation

A series of studies shall be undertaken over a range of operating conditions, including pre-synchronizing, post-synchronizing, variation in grid voltage, auxiliary transformer failure, etc., to demonstrate that the plant electrical equipment operates within its manufacturer's rating and the voltage at all buses is maintained in the required range. For the studies, cable impedance shall be included and transformer and generator impedance shall include the maximum positive tolerances.

Transformer impedance shall be determined to optimize the through-fault withstand current of the transformer and the interrupting duty of the switchgear and switchyard breakers and to ensure that the voltage will not fall below allowable limits when the largest motor will be started.

The studies shall include motor starting studies to show that, when starting any motor, the distribution voltage at all levels does not fall below 90% of motor nameplate rating except for motors designed for lower terminal voltage. This requirement shall apply for all the contingencies given above and include motors of the largest starting current at each voltage level. Motors subject to the low starting voltage will be rated for 80% starting voltage.

Evaluate generator step-up transformer reactive power flow study to verify that transformer does not reduce generator reactive power flow through all operating conditions. Reactive power flow shall be evaluated in accordance with IEEE C57.116 to meet a power factor of 95% lagging and 95% leading for each unit at the 345 kV side of the generator step-up transformer.

System design shall provide for transmission voltage deviation of plus or minus 5% and short term (one minute or less) voltage excursions of plus 10% to minus 10%. During normal operation system bus voltage shall be within plus or minus 5% of nominal voltage. Auxiliary equipment shall be designed for continuous operation for a plus or minus 10% voltage variation.

1. Fault level

Studies shall be undertaken to ensure that the prospective fault current is within the rating of the switchgear and cables. For these studies: cable impedance shall be ignored, full motor contribution shall be included, and transformer impedance shall be at the maximum negative tolerance.

2. DC System Studies

A load profile shall be developed for all DC loads to size the batteries and chargers, and to verify minimum voltages are maintained as specified and required by equipment vendors.

3. Grounding Studies

Perform grounding system studies using a minimum of a 2 layer model to limit touch and step potentials to safe values as specified. The calculation of the ground resistance shall include the switchyard area and plant. The grounding system shall be designed to provide personnel safety and to provide protection to electrical equipment. The grounding system study shall be in accordance with the requirements of IEEE 80, 81, 81.2, 142, 665 and

1050, NESC and the NEC. Soil resistivity shall be measured as described in IEEE 80.

#### 4. Arc-Flash Study

Perform arc-flash study for medium voltage switchgear, contactors, 480 volt switchgear, 480 volt motor control centers, and 480 volt distribution panels. Study shall be performed based on IEEE 1584 – Guide for Performing Arc-Flash Hazard Calculations. Arc-flash study shall calculate incident energy and boundary areas where no special clothing or personal protective equipment is required. Arc-resistant equipment shall be furnished for medium voltage busses. Incident energy shall be limited to a maximum of 40 cal/sq-cm for all 4160 and 480 volt busses.

#### 5. Protective Relay Coordination Study

A protective relay coordination study and relay setting report shall be prepared. This study will serve as the basis for relay protection for the plant electrical distribution systems. Relay settings are required for all protective relays furnished by Contractor. Recommended settings for combustion and steam turbine relays will be provided by equipment supplier. Contractor shall provide settings for relays requiring system information. Contractor shall request any information from Owner to provide relay settings. Contractor shall provide a hardbound report including settings, calculations, system data, one lines, and coordination curves. In addition a CD shall be furnished including all documents in the report, relay setting files, relay communication software, instruction manuals, and application manuals where applicable. Contractor shall coordinate with the local utility company to implement any special protection or system requirements.

### 8.1.2 Interface Requirements

#### 8.1.2.1 Utility System Interface

The interconnection of the plant into the Utility system will be through a 345 kV switchyard extension. The switchyard will be supplied by Others under a separate Contract. The interfaces as described in the following will refer to Owner's switchyard. The switchyard interface will be at the following points:

1. Generator step up transformer dead end structure (switchyard Contractor will install overhead line to dead end structure and make drops to transformer)
2. Switchyard relaying, metering, SCADA , communications switchyard station service power marshaling junction box.
3. Grounding consisting of two connections per step up transformer plus one connection per duct bank.

A generator fault on a combustion turbine shall trip only its associated generator excitation and low side generator circuit breaker. This scheme should allow the auxiliary loads to continue receiving the power supply from the switchyard through the corresponding station auxiliary transformer. A fault on a step-up transformer shall trip its high side circuit breakers and associated generator breaker. A fault on the steam turbine generator shall trip its associated high voltage breakers.

Contractor shall coordinate with Owner's switchyard contractor for routing of circuits to the switchyard control building. In addition to the required raceways, Contractor shall provide two spare 4" conduits from administration building to Owner's switchyard.

Contractor shall interface with Utility company and Owner's switchyard contractor for interconnection of the power plant at least but not limited to the following technical areas:

1. Basic System Design
2. Protective Relays of the generation system.
3. Engineering Studies
4. Metering
5. Telemetry
6. Generator synchronizing
7. Reactive Power Requirements
8. SCADA Dispatch Control
9. Backup power supply
10. Dead end structure line termination

Contractor shall include interfaces to an RTU (remote terminal unit) located in the switchyard control building. The interface shall include as a minimum the following isolated metering, control, and status points per unit:

1. Gross megawatts
2. Net megawatts
3. Auxiliary megawatts
4. Station net megawatts
5. Gross megavars
6. Net megavars
7. Auxiliary megavars
8. Generator voltage
9. Upper operating limit
10. Lower operating limit
11. AGC control status
12. Power system stabilizer status
13. Voltage regulator status

Final point list shall be developed during Contract execution, and shall include additional points typical of this type of installation.

Furnish and install plant side revenue metering system consisting of Maxsys 2510 revenue meters for each generator and auxiliary transformer, current transformers, and potential transformers for combustion turbine generator gross (low side for each unit), combustion turbine auxiliary load (each unit) and steam turbine gross (low side). Meters shall be furnished with 5759 firmware, peer to peer networking capability, bi-directional metering capability, DNP 3.0 communications protocol, 4 KYZ outputs, and 4 analog outputs. Meters shall be connected to allow internal calculation of net unit and station power. Meters shall be connected to dedicated revenue quality current and potential transformers. Owner will supply meter catalog number. Provisions shall be included to accumulate auxiliary power when the CT units are off line in separate registers or other methodology as approved by Owner. Hardwired analog, pulse, and communication outputs shall be made to switchyard RTU. Metering to have remote dial up capability.



Provide rack space, 48V 150A-H battery and charger system for the Owner provided DMXplore and Channel bank communications equipment. Furnish conduits and fiber cable between the new 345 kV switchyard and the communications equipment.

Owner will ultimately enter into a power supply agreement in accordance with the Large Generation Interconnection Agreement (LGIA) and associated documents included in Appendix H\_. Contractor shall include all technical and operational requirements within the plant to design to meet the requirements of the LGIA and associated documents.

#### 8.1.2.2 Plant Synchronizing and Switching Scheme Interface

Contractor shall design a synchronizing scheme in coordination with the turbine supplier. Combustion turbines will be synchronized across low side generator breakers and the steam turbine will be synchronized across the switchyard breakers. Design shall be based on a single high side breaker connected to a collector bus.

As required to ensure proper synchronization operation, phase matching potential transformers shall be provided to compensate for any phase angle and potential differences (caused by step-up transformer phase-shift) on the derived voltage sources from the switchyard and generator systems. Potential selection relays and selection logic shall be included as part of the synchronizing scheme.

#### 8.1.3 Auxiliary Power Supply Equipment

The auxiliary power supply equipment includes the unit auxiliary transformers, 4160-volt switchgear, 4160-volt motor control centers, 480-volt secondary unit substations, 480-volt motor control centers, 480/277-volt distribution panelboards, and 208/120-volt power panels. All 4160 volt switchgear and 4160 volt motor control centers shall be arc-flash resistant. The auxiliary power equipment shall distribute electrical power to the plant auxiliary equipment. Electrical equipment with the exception of transformers shall be installed in rooms with a controlled environment including redundant air conditioning, except as approved by Owner. Each class of primary distribution equipment (4160-volt switchgear, 4160-volt MCC, 480-volt switchgear, 480-volt MCC's) shall be of the same type and manufacture (i.e. all 4160-volt switchgear shall be of the same type and manufacture, but not necessarily the same manufacture as the 480-volt switchgear).

Critical loads for each block will be configured in such a manner that critical loads can be easily and quickly isolated from the normal source and transferred to the backup source (emergency diesel generator). Included in the critical loads are the loads to keep the combustion turbines in a ready to start condition, steam turbine critical loads, DC system, HVAC, communications and other loads as selected by Owner. Loads shall be selected up to the capacity limit of the emergency diesel.

Each 4160 and 480 volt bus shall be provided with metering functions to include, 3-phase bus voltage, 3-phase current, kW, kVAR, kWh (meter functions may be provided through protective relay data to DCS). Summary metering shall be configured to provide total kW, kVAR, kWh for the station and the auxiliary power system. The station service power shall be supplied from the utility system during plant startup, shut down, and maintenance periods. Power shall be supplied from the generated power during normal operation. Primary control for medium and low voltage switchgear, mains, ties, and feeders shall be from the distributed control system. Backup control shall be provided

near the switchgear to allow buses to be energized if the DCS is out of service. DCS shall display feeder and bus metering information in addition to switchyard voltage.

The quantity and size of 480 volt panel boards shall be selected such that the capacity is adequate for total running load under all operating conditions, plus a 20% design allowance, plus 10% allowance for future use. The continuous current ratings and interrupting ratings of the feeder breakers shall be based on the available fault current and the characteristics of the connected load. Each distribution panel board shall include the feeder breakers required to supply the connected load, plus two three-pole and two single-pole feeder breakers for future use.

Welding receptacles shall be provided for portable 480 volt, 3-phase welding equipment. Sixteen receptacles will be placed in strategic locations as directed by Owner.

All 208 volt loads and all single-phase 120 volt loads shall be supplied from the 208/120-volt power panels. The continuous current rating of the main bus and the 480-208/120-volt transformer shall be as required plus a 20 percent design allowance. The continuous current ratings and interrupting ratings of the feeder breakers shall be based on the available fault current and the characteristics of the connected load. Distribution transformers shall be dry type, U.L. listed, class H insulation (based on a 115 degrees C rise) with 4 – 2½ % FCBN and 2 – 2 ½ % FCAN taps in primary winding with suitable enclosure. Motor space heaters, equipment space heaters, equipment lights and receptacles and equipment miscellaneous power feeds shall be from power panels. Each power panel shall include the feeder breakers required to supply the connected load, plus 6 single-pole feeder breakers for future use.

#### **8.1.4 Classification of Hazardous Areas**

Areas where flammable and combustible liquids and gases are handled and stored shall be classified for the purpose of determining the minimum criteria for design and installation of electrical equipment to minimize the possibility of ignition. The criteria for determining the appropriate classification are specified in Article 500 of the National Electric Code (NFPA/ANSI C1). The application of these criteria to specific areas at generating stations is provided in Article 127 of the National Electrical Safety Code (ANSI C2) and applicable NFPA standards.

#### **8.1.5 Lighting**

A lighting system shall be furnished for all structures and new equipment. The lighting system shall provide personnel with illumination for plant operation under normal conditions, means of egress under emergency conditions, and emergency lighting to perform manual operations during a power outage of the normal power source. Provide aviation lighting system for stacks if required . The power supply for the lighting system shall be from 120/208 or 277/480 volt, 3-phase, 4-wire lighting panelboards. Emergency lighting shall be powered from a 120 volt AC normal source with local battery backup.

The lighting system shall be designed in accordance with the Illuminating Engineering Society (IES) to provide illumination levels recommended by the following standards and organizations:

1. ANSI IIES RP-7, 1979, Industrial Lighting.

2. ANSI IIES RP-8, 1977, Roadway Lighting.
3. Federal Aviation Administration (FAA).
4. Occupational Safety and Health Act (OSHA).

In addition to the above, the lighting design shall meet all local codes and regulations. Lighting sources and fixture selections shall be based on the applicability of the luminaries for the area under consideration.

Four types of lamps shall be used for the light sources in the lighting system including fluorescent, high-pressure sodium, metal halide, and incandescent.

Generally, fluorescent lamps shall be used in indoor, low-bay enclosed areas; high-pressure sodium lamps shall be used outdoors, metal halide in high-bay enclosed areas, and incandescent lamps shall be used for emergency lighting. Exterior lighting shall include all roadways, HRSG platforms, combustion turbine platforms, CEMS equipment platform areas, and evaporation pond sump. Lighting levels shall be designed to at least the following minimum foot-candle levels:

- |                                  |       |
|----------------------------------|-------|
| 1. Platforms, stairs, & walkways | 10    |
| 2. Maintenance areas             | 50    |
| 3. Toilets and locker rooms      | 40    |
| 4. Warehouses/mechanical rooms   | 20-30 |
| 5. Water treatment               | 30    |
| 6. General outside areas         | 1     |
| 7. Roadway and parking areas     | 1     |
| 8. Electrical rooms              | 50    |

In general outside areas shall be controlled by photocell. Outside areas such as HRSG platforms shall have auto/manual stations to selectively turn-off lights when plant is not operating.

#### 8.1.6 Telephone and Data Systems

Contractor shall expand the existing telephone/data network to include the Block 2 equipment. As a minimum voice/data lines shall be installed to the areas tabulated below. The telephone / data system design including all equipment shall be approved by Owner. Provide dedicated raceway system from the control room building to the plant terminal point for telephone cable. Owner will supply and install the telephone and data switching equipment.

Contractor shall include a raceway system, wiring, jacks, and switches as required for the telephone and communications system indicated below. Listing is per building when multiple buildings are included.

Facility	Voice	Data	Analog
Administration Building	4	4	2
Boiler Feed Pump Enclosure	1	1	1
Chemical Treatment Building	1	1	1
Power Distribution Building	1	1	2
CEMS	1 Each	1 Each	1 Each
CT Electrical building	1 Each	1 Each	2 Each

ST& CT Excitation Building	1	1	2
Gas Regulating station		1 (fiber)	2

Final locations will be determined by Owner during detailed design.

Provide data ports with interconnecting Category 6 wiring for 100 mbps plant network at locations near the phone outlets. Data ports in other buildings remote from the Control/Administration building will be connected through fiber optic cable unless otherwise approved.

### 8.1.7 Construction Power

Contractor shall contact local utility and make arrangements for construction power services. Contractor shall pay all fees and operating costs associated with the installation, operation, and maintenance of the service including removal at project completion. Construction power shall be available through the duration of the project up to commercial operation unless approved by Owner. Owner will furnish power for commissioning and startup through back-feed of the auxiliary transformers. This power source will not be available for construction.

### 8.1.8 Freeze Protection

A freeze protection system shall be provided for piping, instrument impulse lines (integral tubing bundles), gauges, pressure switches, and other devices subject to freezing. See Division 5 and 9 for additional requirements. All transmitters, remote gauges and switches located outdoors shall be located in a heated instrument enclosure complete with a thermostat and space heater which will automatically turn on when the ambient temperature falls below 40 F. The enclosures shall be designed such that the heater cable circuit for the integral tubing bundle connecting the instrument to the process is terminated inside the enclosure.

On pipes that operate below 300°F, parallel circuit type heating cable shall be directly applied to the pipe. These heating cable circuits can be assembled and installed in the field using the appropriate connection kits.

For pipes which operate at 300°F and above, parallel circuit-type heating cable shall be sandwiched between layers of insulation or heat tracing of suitable temperature rating shall be used. These heating cable circuits can be assembled and installed in the field using appropriate connector kits.

Power distribution panelboards, each fed from 480-120/208 volt transformers shall furnish power to the freeze protection circuits. Power to the freeze protection circuits shall be controlled by ambient thermostats through a central control panel which shall provide control and alarm/monitoring functions for the freeze protection system. In addition, thermostats that sense actual pipe temperature may be required to prevent overheating of critical process or chemical piping. Remote alarms for the overall system and local monitoring of each freeze protection circuit shall be provided.

### 8.1.9 Cathodic Protection System

Cathodic protection and other corrosion control measures shall be provided to protect metal tank bottom and underground piping and shall be designed and installed

according to soil survey results. A study shall be prepared by a corrosion control specialist (member of NACE) to provide recommendations as to the requirements for, and methods of, preventing corrosion of metallic elements due to galvanic action. This study shall be submitted for review by Owner. The study shall include a conceptual design, including comparison of active versus passive corrosion control methods, and a bill of material for implementation of any recommended corrosion control system.

#### **8.1.10 Lightning Protection**

Lightning protection system shall be provided for building structures, transformers, the GT packages (including HRSG and stacks (regardless of stack thickness), the cooling tower stacks, and tanks.

Lightning protection for the building structures shall consist of air terminals installed at the highest points. The air terminals shall be connected together with copper cable and connected to the plant ground grid with copper down conductors. Protection system will be certified with a Master Label.

### **8.2 ELECTRICAL PROTECTIVE SYSTEMS**

This Contract shall furnish and install a coordinated protective relay system to detect faults and trip the appropriate equipment. Owner will review and approve all protective relay equipment, logic, nomenclature and settings to verify consistency with the specifications and Owner's standards. Contractor will coordinate with switchyard supplier to ensure a proper interface.

In general protective relays are to be based on the Schweitzer relay products unless specifically approved by Owner. Any grouping of relays shall be provided with an SEL-2030 for remote modem access. Contractor to include communication lines to allow remote dial up capability. All protective relays shall be time synchronized using a station IRIG-B time signal. All relay currents, potentials, and trips shall be wired through test switches. When required relay outputs shall trip ElectroSwitch type LOR lockout relays with a minimum of 10 decks. Owner shall provide assignment of relay output contacts. All current, potential, and lockout trip contacts shall be wired through clear cover test switches.

#### **8.2.1 Generator Protective Relays**

The generator protection system shall be based on redundant SEL-300G multifunction relays. Relays shall include the following protective functions: 21 backup impedance; 24 volts/hertz; 32 Multi-step reverse power; 27TN/59N 100% stator ground fault; 46 Phase unbalance; 50/27 inadvertent energization; 50BF breaker failure (combustion turbines); 59 over voltage elements; 59N bus ground fault; 60 loss of potential detection; 78 out-of-step protection; 87 differential protection. In addition to protective functions relay shall have extensive metering capability, oscillography, self-diagnostics, and communication capability.

Each SEL-300G will be provided a lockout relay for turbine tripping and a lockout relay fro generator tripping. Tripping, blocking, and initiate logic shall be consistent with Owner's operating requirements and coordinated with the switchyard protection.

### **8.2.2 Generator Step-up Transformer Relays**

The primary protection shall be an SEL-387E that only includes the transformer windings in the protective zone. Relay shall trip dedicated lockout relay. Backup relaying shall be dual SEL-387's connected in unit differential configuration. Backup relays shall trip dedicated lockout relays. The protection zone shall include the 345 kV breaker, generator and auxiliary transformer tap (steam turbine does not have auxiliary transformer.) Dual sudden pressure contacts and dual neutral current transformers shall be provided as inputs to the protective relays.

### **8.2.3 Unit Auxiliary Transformer Relays**

Protection for auxiliary transformers shall include an SEL-387E with a protective zone including the auxiliary transformer and switchgear main breaker. Provide lockout relay for status, blocking, and tripping functions.

### **8.2.4 Medium Voltage Switchgear and Motor Controllers**

Provide SEL-351A multifunction protective relays for mains, ties, and non-motor feeder breakers. SEL-701 shall be used for protection for motor feeders. Relays will be configured to detect faults or abnormal operating conditions and trip appropriate breaker or alarm operator and coordinated with other protective devices. Any trip operations will include lockout functions to block closing of breakers without operator intervention.

## **8.3 SWITCHYARD**

Others will design and install the switchyard and equipment from the high side of the step-up transformers to the switchyard except as specified. Contractor shall coordinate design between Contractor and Switchyard Contractor to determine placement of dead end structures, transformers, protective relay settings, interface junction box, RTU communication connections, power feeds and associated details.

This Contract shall provide two separate 480 volt feeds (200A each) to the substation to provide redundant AC auxiliary power sources for the substation. Contractor shall also provide two, 125 VDC, 100A each and one 1 kVA 120 volt UPS supply to the switchyard control building interface cabinet by the Switchyard Contractor.

### **8.3.1 Deadend Structures**

EPC Contractor shall provide one dead-end structure for each GSU. Dead end structure shall have a conductor height of 45 feet, a shield wire height of 20 feet, mast height of 20 feet, phase spacing of 20 feet and a line angle from 0 to 20 degrees. Design conditions shall be NESC heavy loading. The structure shall be designed using the ultimate stress method. The following are the maximum loads:

1. Conductor Loading - 3000 lb per conductor
2. Shield Wire Loading – 2500 lb per wire

EPC Contractor shall provide engineering, procurement, and installation of GSU switches and dead end structures including all supporting systems. These systems include but are not limited to all low and high voltage cable, conductor, and connectors; raceway; foundations; grounding; and monitoring, controls, and protection. All high-

voltage systems shall be coordinated with plant and switchyard design and installation. Owner will approve final design and arrangement of dead end structure.

#### **8.4 GENERATOR STEPUP TRANSFORMERS**

This section covers power transformer equipment, material, and accessories. The power transformers furnished shall have all standard and normally supplied accessories ready for installation, connection, and immediate service. The following requirements are to be used in conjunction with the applicable sections of the Owner's specifications for transformers 'Material Specification ZS 001-2004, Substation Equipment – Power Transformer All Ratings' included in Appendix F.

Transformers shall be generator unit step-up transformers (GSU), shall be 345 kV nominal secondary, and generator rated voltage nominal primary, and shall be rated a minimum 5% over generator capability throughout the full ambient operating range with a temperature rise limited to 65°C. The method of cooling shall be ONAN/ONAF/ONAF. Step up transformers for the combustion turbines shall be designed for a minimum guaranteed efficiency of 99.7% and the steam turbine 99.75% at the top ONAF rating.

On initial selection of transformer supplier, Contractor shall provide Owner with the guaranteed load and no load losses for the step-up transformers at the top ONAF rating. In the event the tested losses are greater than the guaranteed losses, Contractor shall reduce the contract price by the sum of \$4,000/ kW for no load losses above the guaranteed value and \$1,700 / kW for the load losses above the guaranteed value. The no load and load loss evaluation will be performed independently of each other. In the event losses are less than the guarantee value, the Contract Price shall be increased by the sum of \$2,000 / kW for no load loss differential plus \$850 / kW for the load loss differential.

Transformer high voltage winding BIL shall be a minimum of 1050 kV with 350 kV neutral. High voltage bushing shall have minimum BIL of 1175 kV. Low voltage winding shall have a minimum BIL of 150 kV. Transformer size, impedance and high side tap shall be selected to allow full range of generator reactive capability at the system nominal voltage. Transformer impedance shall be approximately 6% on an ONAN base and 10% at maximum rating. In addition, transformer impedance shall be selected to limit fault current below generator breaker interrupting level, and allow starting of largest plant motor without exceeding NEMA starting criteria.

All equipment shall conform to the applicable standards of ANSI, NEMA, and IEEE and shall be in accordance with the applicable requirements of OSHA standards. The latest published edition of referenced standards shall apply. The power transformers shall be designed, fabricated, and tested in accordance with ANSI C57 series, C62, NEMA TR 1, and these Specifications.

Transformers shall be provided with oil containment and drainage to the plant oil water separator. Drain lines shall be provided with normally closed manual drain valves.

Transformers shall be provided as a minimum with the following accessories and capabilities:

1. 4 (four) full capacity 2 1/2% taps, 2 (two) above and 2 (two) below nominal voltage rating for manual "no-load" operation.
2. Standard angular displacement of voltages.
3. Sound level not to exceed 85 dBA at 3 feet at top ONAF rating (or less if required to meet project sound limitations).
4. Continuous over excitation capability of 110% at full load and 125% for 30 seconds.
5. Manholes located in cover.
6. Lockable tap changer handle accessible from ground level.
7. Short circuit capability with only transformer impedance limiting fault current.
8. Accessible core ground bushing and well for core ground.
9. Detachable radiators with lifting eyes and upper and lower isolation valves.
10. Upper and lower filter connections with sample valves.
11. Qualitrol temperature monitor with a minimum of 8 output contacts, diagnostic alarm, communications capability, and analog outputs.
12. Oil temperature and level gauges.
13. Conservator or sealed tank with inert-gas pressure oil preservation system.
14. Pressure relief device with a semaphore visible from ground level.
15. NEMA 3R control cabinet with latchable doors.
16. Adequate number of current transformers with relay accuracy of C800 and metering accuracy of 0.3B1.8 (or as required by interconnect standards) for plant metering and relaying including any relaying interface with substation. Current transformers shall have a minimum thermal rating factor of 2.0. A minimum of three current transformers on high side with at least one with metering accuracy and two on the low side.
17. Dual neutral current transformers.
18. Station Class surge arresters (internal surge protection not acceptable) with an MCOV of not less than 110% of line to ground voltage.
19. Discharge counters.
20. Sudden pressure relay device with dual outputs.
21. Fall protection device mounting provisions.
22. Serveron on-line gas analysis monitor with communications capability to the plant DCS, alarm and configurable analog outputs.
23. Copper windings with EHV-Weidmann insulation and materials suitable for 120° C continuous operation.
24. Local annunciator with common alarm or adequate alarms in DCS to quickly identify alarm source.
25. Maximum core flux density of 1.7 Tesla at no load and 100% rated tap voltage.
26. One spare high and low voltage bushing.
27. High temperature gasket material (Viton).

Factory Tests:

1. Notify Owner not less than two weeks prior to the starting date of the factory tests to permit observers to be present during the factory tests.
2. Procedures for factory tests shall conform to ANSI C57.12.90, unless otherwise specified. Except where a specific test method is specified, the factory test report shall state the test method used. Perform the following factory tests on each transformer unless otherwise stated:
  - a. Winding ratio on rated voltage connections and on all tap positions.



- b. Winding polarity and phase relation on the rated voltage connections.
  - c. Excitation loss at 100% and 110% of rated voltages on the rated voltage connections.
  - d. Excitation current at rated voltages, and at 110% rated voltages, on the rated voltage connections.
  - e. Impedance and load loss at the maximum 65°C rating.
  - f. Temperature rise at the maximum 65°C rating for the transformer supplied under this contract. Records of temperature tests performed on duplicate or essentially transformers will not be acceptable.
  - g. Temperature indicator accuracy test.
  - h. Applied potential test.
  - i. Induced potential test with the transformer connected at rated voltage, with the transformer's own bushings in place, accompanied by partial discharge monitoring (to conform to ANSI C57.12.90).
  - j. Lightning impulse tests on all winding terminals, with the transformer's own bushings in place.
  - k. Switching surge tests on the high-voltage winding, with the transformer's own bushings in place.
  - l. Test all control wiring for continuity, grounds, and correct connections; and test operation of all relays, indicators, switches, lights, and interlocks.
  - m. Resistance measurements of all windings on the rated voltage connection and all load tap connections. Test results shall be reported in ohms at 75°C
  - n. Double insulation power factor tests conforming to Method II in Table 4 of Article 10.10 of ANSI C57.12.90. The power factor shall be equal to or less than 0.5% at 20°C.
3. Perform the manufacturer's standard tests on each surge arrester.

## **8.5 PLANT AUXILIARY TRANSFORMERS**

Transformer shall be suitable for operation throughout the full ambient temperature operating range. The method of cooling shall be ONAN/ONAF. Transformers shall have a minimum efficiency of 99.5% at the top rating. Transformer spare capacity at the top ONAF rating may drop below 20% when one auxiliary transformer is out of service. The following requirements are to be used in conjunction with the applicable sections of the Owner's specifications for transformers 'Material Specification ZS 001-2004, Substation Equipment – Power Transformer All Ratings' included in the appendix.

On initial selection of transformer supplier, Contractor shall provide Owner with the guaranteed load and no load losses for the auxiliary transformers at the top ONAF rating. In the event the tested losses are greater than the guaranteed losses, Contractor shall reduce the contract price by the sum of \$4,000/ kW for no load losses above the guaranteed value and \$1,700 / kW for the load losses above the guaranteed value. The no load and load loss evaluation will be performed independently of each other. In the event losses are less than the guarantee value, the Contract Price shall be increased by the sum of \$2,000 / kW for no load loss differential plus \$850 / kW for the load loss differential.

The continuous rating of the unit auxiliary transformers shall be as required to supply electrical power to the total plant (two combustion turbines and one steam turbine)

auxiliary load under all operating conditions but not to exceed 4160 volt switchgear capability. Transformers shall be 100% redundant. The transformer impedance shall be selected to provide adequate voltage regulation and motor starting capability under all operating conditions.

All equipment shall conform to the applicable standards of ANSI, NEMA, and IEEE, and shall be in accordance with the applicable requirements of OSHA standards. The latest published edition of referenced standards shall apply. The power transformers shall be designed, fabricated, and tested in accordance with ANSI C57.12 series, C62, NEMA TR 1, and these Specifications.

Transformers shall be provided as a minimum with the following accessories and capabilities:

1. 4 (four) full capacity 2 1/2% taps, 2 (two) above and 2 (two) below nominal voltage rating for manual "no-load" operation.
2. Standard angular displacement of voltages.
3. Sound level not to exceed 85 dBA at 3 feet at the top ONAF rating.
4. Continuous over excitation capability of 110% at full load and 125% for 30 seconds.
5. Manholes located in cover.
6. Lockable tap changer handle accessible from ground level.
7. Short circuit capability with only transformer impedance limiting fault current.
8. Accessible core ground bushing and well for core ground.
9. Detachable radiators with lifting eyes and upper and lower isolation valves.
10. Upper and lower filter connections with sample valves.
11. Qualitrol temperature monitor with a minimum of 8 output contacts, diagnostic alarm, communications capability, and analog outputs.
12. Oil temperature and level gauges.
13. Pressure relief device with a semaphore visible from ground level.
14. Control cabinet with latchable doors.
15. Adequate number of current transformers with relay accuracy of C800 and metering accuracy of 0.3B1.8 (or as required by interconnect standards) for plant metering and relaying. At least one set of CT's on primary shall have metering accuracy. Current transformers shall have a minimum thermal rating factor of 2.0.
16. Sudden pressure relay device.
17. Serveron on-line gas analysis monitor with communications capability to the plant DCS, alarm and configurable analog outputs.
18. Copper windings with EHV-Weidmann insulation and materials suitable for 120° C continuous operation.
19. Maximum core flux density of 1.7 Tesla at no load and 100% rated tap voltage.
20. Fall protection device mounting provisions.
21. Grounding resistor.
22. Local annunciator with common alarm.
23. High temperature gasket material (Viton).

Factory Tests:

1. Notify Owner not less than two weeks prior to the starting date of the factory tests to permit observers to be present during the factory tests.
2. Procedures for factory tests shall conform to ANSI C57.12.90, unless otherwise

specified. Except where a specific test method is specified, the factory test report shall state the test method used. Perform the following factory tests on each transformer unless otherwise stated:

- a. Winding ratio on rated voltage connections and on all tap positions.
  - b. Winding polarity and phase relation on the rated voltage connections.
  - c. Excitation loss at 100% and 110% of rated voltages on the rated voltage connections.
  - d. Excitation current at rated voltages, and at 110% rated voltages, on the rated voltage connections.
  - e. Impedance and load loss at the maximum 65°C rating.
  - f. Temperature rise at the maximum 65°C rating for the transformer supplied under this contract. Records of temperature tests performed on duplicate or essentially transformers will not be acceptable.
  - g. Temperature indicator accuracy test.
  - h. Applied potential test.
  - i. Induced potential test with the transformer connected at rated voltage, with the transformer's own bushings in place, accompanied by partial discharge monitoring (to conform to ANSI C57.12.90).
  - j. Lightning impulse tests on all winding terminals, with the transformer's own bushings in place.
  - k. Switching surge tests on the high-voltage winding, with the transformer's own bushings in place.
  - l. Test all control wiring for continuity, grounds, and correct connections; and test operation of all relays, indicators, switches, lights, and interlocks.
  - m. Resistance measurements of all windings on the rated voltage connection and all load tap connections. Test results shall be reported in ohms at 75°C
  - n. Double insulation power factor tests conforming to Method II in Table 4 of Article 10.10 of ANSI C57.12.90. The power factor shall be equal to or less than 0.5% at 20°C.
3. Perform the manufacturer's standard tests on each surge arrester.

## **8.6 4160 VOLT METAL-CLAD SWITCHGEAR**

### **8.6.1 General**

This section covers the furnishing of 4160 volt vacuum metal-clad indoor switchgear equipment, material, and accessories. Equipment shall be provided in accordance the conceptual one-line diagram. Switchgear will have continuous ratings as required and short circuit duty of 350 MVA. Switchgear shall be arc-resistant. Switchgear will be of the same type and manufacture.

The continuous current rating, short-circuit interrupting capability, and short time current carrying capability of the 4160 volt switchgear and 4160 volt motor control center shall be coordinated with the ratings of the unit auxiliary transformer and the characteristics of the connected loads. All motors rated 4000 volts and all 480 volt secondary unit substations shall be supplied directly from the 4160 volt switchgear or 4160 volt motor control center. The 4160 volt switchgear shall be furnished with potential transformers and current transformers as required for protective relaying, metering, and control. Provide surge arresters on mains and feeder breakers.

Switchgear main bus shall be fully insulated copper. Control power shall be 125 VDC with mains, tie, and feeders controlled from the plant DCS.

Relays will be configured to detect faults or abnormal operating conditions and trip appropriate breaker or alarm operator and coordinated with other protective devices. Any trip operations will include lockout functions to block closing of breakers without operator intervention. Motor feeders 2500 hp or larger shall be provided with differential protection.

## **8.7 4160 VOLT MOTOR CONTROL CENTERS**

### **8.7.1 General**

These specifications cover 4160 volt, general purpose, indoor motor control centers. The continuous current rating, short-circuit interrupting capability, and short time current carrying capability of the 4160 volt motor control center shall be coordinated with the ratings of the unit auxiliary and the characteristics of the connected loads. Motor control centers shall be arc-resistant.

The motor control centers shall be designed and fabricated with all normally supplied accessories for use on a 4160 volt, 3-phase, 60-hertz, 60 kV BIL, resistance grounded system, and shall be coordinated to protect motors over the complete range of overload and fault conditions. Construction of Motor Control Centers shall allow either one-high or two-high arrangements. Lifting apparatus shall be provided for the two-high arrangements. Provisions shall be made so that the Motor Control Centers can be extended to include additional sections in the future.

#### **8.7.1.1 Codes and Standards**

All motor starters and motor control center components shall be designed and fabricated to conform to the requirements of NEMA standards for Class E-2 Industrial Control Equipment and to the requirements of applicable IEEE and ANSI standards. All materials and devices shall be in accordance with the applicable requirements of the Federal "Occupational Safety and Health Standards". The latest edition of these codes and standards shall be applied to the manufacture of the equipment

## **8.8 480 VOLT SECONDARY UNIT SUBSTATIONS**

### **8.8.1 General**

The equipment shall include coordinated assemblies of incoming line, transformer, and outgoing feeder sections with all auxiliary and transition compartments necessary to provide unit substations ready for installation, connection, and immediate service.

Each power transformer included with each secondary unit substation shall be rated to supply the total 480 volt auxiliary load plus 30 percent under all operating conditions and 110% of the auxiliary load when the tie breaker is closed and one transformer is out of service. The transformer impedance shall be selected to provide adequate voltage regulation and motor starting capability under all operating conditions. The continuous current ratings and interrupting ratings of the main breakers, tie breakers, feeder breakers, and main bus shall be coordinated with the ratings of the power transformers

and the connected loads. Breakers shall be drawout air magnetic units. The secondary unit substations shall include feeder breakers required to supply the connected load, plus one additional equipped space for future use on each bus.

Overload and fault protection for loads connected to the 480 volt secondary unit substations shall be provided by solid-state trip devices which are an integral part of the drawout type air circuit breakers or separately mounted panel devices. Integral trip devices shall include long time, short time, instantaneous, and ground functions as required for a coordinated system. Trip units shall display metering information. If required, auxiliary power shall be provided for trip unit display at low loads.

General arrangement of unit substation shall be as indicated on the conceptual one-line diagram. This Contract shall provide substations of quantity and sizes to support the plant loads. One spare breaker of each frame rating (except for mains) shall be included for future use. Main and tie breakers shall have same rating and be electrically operated. MCC feeder breakers shall be manually operated.

Transformers for 480-volt secondary substations may be oil filled or cast coil for outdoor applications, or vacuum pressure impregnated (VPI) dry type for indoor applications. If dry type, they shall be indoor close coupled to 480-volt switchgear. Oil transformers shall have a maximum of 65° C rise, cast coil 80°C rise, and VPI 115°C rise. Oil filled units shall have high side BIL of 60 kV and low side BIL of 30 kV, ventilated dry type shall have BIL of 45 and 10 kV respectively, and cast coil 75 and 30 kV respectively. Transformers shall be low loss units and have a minimum efficiency of 99%. Transformers shall have the following accessories:

1. Externally operated no load tap changer.
2. Lower drain valve and liquid sampling device (for oil type).
3. Dial-type thermometer with contacts for cooling control and high-temperature alarm.
4. Magnetic liquid level gauge with alarm contact for low level (for oil type).
5. Pressure/vacuum gauge (for oil type).
6. Lifting lugs and jacking pads.
7. Pressure relief device (for oil type).
8. Two ground pads, on diagonally opposite corners.
9. All other standard accessories.

#### 8.8.1.1 Codes and Standards

Unit substation components furnished under these specifications shall be in accordance with the requirements of applicable IEEE, NEMA and ANSI standards. All materials and devices shall be in accordance with the applicable requirements of the Federal "Occupational Safety and Health Standards". The latest edition of these codes and standards shall be applied to the manufacture of the equipment

## **8.9 480V MOTOR CONTROL CENTERS**

### **8.9.1 General**

Contractor shall furnish and install motor control center equipment, materials, and accessories as specified herein. The motor control centers shall be designed and constructed for use on a 480 volt, 3-phase, 60-hertz, 3-wire, solidly grounded system. Except as specified otherwise, all equipment shall be designed for service with an ambient temperature of 40°C.

All equipment furnished under these Specifications shall conform to applicable standards of IEEE, ANSI, and NEMA. Motor control centers shall conform to UL 845, NEMA ICS1, NEMA ICS2, NEMA ICS4, and NEMA ICS6. All materials and devices shall be in accordance with the applicable requirements of OSHA standards. The latest edition of these codes and standards shall be applied to the manufacture of the equipment.

The continuous current rating of the motor control center main bus shall be as required to supply the total running load under all operating conditions, plus a 20 percent design allowance. The bus bracing and the interrupting ratings and continuous current ratings of the combination starters and feeder breakers shall be based on the available fault current and the characteristics of the connected loads. Each motor control center shall include the combination starters and feeder breakers required to supply the connected load, plus 10% spare units for each type size 3 and smaller. Motor control centers main breakers shall be protected by an adjustable long-time and short-time solid state trip device element for phase protection.

Each magnetic starter within an MCC which supplies power to a motor shall be equipped with a magnetic-only molded case circuit breaker and a microprocessor based overload system. Starters shall be supplied with control power transformers. Certain loads will be fed from MCC feeder circuit breakers. The breakers shall be thermal magnetic molded case breakers sized to protect supply cable and individual loads.

All starter units and feeder tap units shall be readily interchangeable with units of the same type and size. At least one spare starter unit of each type and size used in that MCC shall be provided for future use in each motor control center. MCC's shall have provisions and space to expand at least one vertical section.

All units, except Size 5 starter units and 400 ampere frame or larger feeder tap units, shall be automatically disconnected and connected to the bus as the units are removed or replaced in the motor control centers. Size 5 starter units and 400 ampere frame or larger feeder tap units shall have fixed mounting within the motor control centers.

### **8.9.2 Circuit Breakers**

Each combination starter unit and each feeder tap unit shall include one 3-pole, single-throw, 600 volt, molded case air circuit breaker with the appropriate amperes symmetrical interrupting rating at 480 volts. All breakers shall be manually operated with quick-made, quick-break, trip-free mechanisms of the toggle type. The breakers shall be equipped with suitable arc quenching devices. Main current carrying contacts shall be silver-plated and shall be capable of carrying their rated current without exceeding the

Underwriters' Laboratories specified temperature rise. All circuit breakers shall be of the same manufacture.

Manual operating handles shall be furnished on the access doors of starter units and feeder tap units to operate the circuit breakers. Provisions shall be made for padlocking each handle in the open position. Each operating handle shall indicate when the breaker has tripped automatically.

The access doors shall be interlocked with the operating handles to prevent opening the doors normally when the circuit breakers are in the closed position. Provisions shall be made for overriding this interlock.

### **8.9.3 Combination Starter Units**

All combination magnetic full voltage starter units shall include disconnecting and branch circuit over-current protective devices; 480 to 120 volt dry-type control transformers; 480 volt, 3-phase, 60 hertz contactors with microprocessor based overload relays. Control transformer leads, starter overload relay contacts, contactor operating coils, and starter auxiliary contacts shall be wired to marked unit terminal blocks.

Disconnected and branch circuit over-current protection devices shall be magnetic instantaneous trip-only type circuit breakers as previously specified under Circuit Breakers.

## **8.10 GENERATOR TERMINAL EQUIPMENT/ISOLATED PHASE BUS DUCT**

The generator terminal equipment includes the isolated phase bus duct, the generator circuit breakers, the generator transformer, and associated auxiliary equipment. The generator terminal equipment shall provide the interface between the steam turbine generator, combustion turbine generator, and the generator step-up transformers and neutral connections of steam turbine generator. Bus duct shall be selected with suitable continuous, momentary, and BIL ratings for this application and consistent with the applicable standards and considering operating and environmental conditions. Bus shall be provided with pressurized air system to prevent condensation and dust ingress. Bus shall include appropriate seals for connection to hydrogen cooled generators. System shall include adequate gauges, alarms, and controls for automatic operation.

### **8.10.1 GT Generator Bus Duct/Auxiliary Power Connections**

Generator bus duct shall connect generator line terminal unit to the generator breaker and then to the generator step-up transformer with taps to the auxiliary transformers as depicted on the conceptual single-line drawing. Bus duct shall be self cooled with suitable continuous, momentary, and BIL ratings for this application and consistent with the applicable standards and considering operating and environmental conditions. The bus shall be a low loss design. The bus shall include seals at the generator terminals.

Tap bus shall be provided for connection to the auxiliary transformers. Tap bus shall have suitable momentary and continuous ratings.

### **8.10.2 Low Side Generator Breakers**

A generator breaker shall be provided between the combustion turbine and generator step-up transformer. Each generator circuit breaker shall have a continuous current

rating at least 125% of generator rating to transmit the generator output under all normally expected loading conditions. Each breaker shall have a short-circuit interrupting capability and short-time current carrying capability which is equal to or greater than the fault current available under any operating conditions. The potential transformers and current transformers shall be furnished as required for protective relaying, metering, and synchronizing of the generator to the grid.

The surge protection equipment shall include surge arresters and capacitors. The surge protection equipment shall be coordinated with the characteristics of each generator to provide protection for each generator insulation system. Generator breaker shall be provided with dual tripping coils, transformer side surge protection, generator side surge capacitor, isolation switch, grounding switch and generator side grounding switch. The generator breaker shall include all material required for termination of the isolated phase bus duct. Breaker shall be provided with adequate number of current and potential transformers to implement protective relaying as specified or required. At least one PT shall be a broken delta configuration with ferroresonant loading resistor.

Access platforms shall be provided for the normal maintenance and operation of the units.

### **8.10.3 ST Generator Bus Duct**

Generator bus duct shall connect the steam turbine generator directly to its step-up transformer. Provide PT and surge cubicle, and steam turbine bushing terminal enclosure. The isolated phase bus duct and tap bus shall have a continuous current rating as required under all normally expected loading and ambient conditions and suitable momentary ratings. The bus shall include seals at the generator terminals.

All medium voltage, isolated phase bus duct and accessories shall be designed, fabricated, and tested to the latest applicable standards of NEMA, IEEE, and ANSI. The latest editions of these codes and standards shall apply.

## **8.11 NON-SEGREGATED PHASE BUS DUCT**

### **8.11.1 General**

Bus duct shall have continuous and short circuit ratings equal or exceeding all equipment connected to the bus. Bus shall be non-ventilated and include all hot-dipped after fabrication support structures. Flexible connections shall be provided at each termination point to allow for differential settlement. Appropriate sealing method shall be provided for wall penetrations.

### **8.11.2 Bus Enclosures**

Bus enclosures, fitting enclosures, and termination enclosures shall be ventilated-type for indoor locations and totally enclosed non-ventilated type for outdoor locations. Enclosures shall be fabricated from heavy gauge steel or aluminum with removable covers for access to splice points of heaters. All covers or access points shall be gasketed. Welded or riveted connection means shall be used for non-removable construction. Top covers shall be solid, removable, and gasketed. Removable bottom covers shall be provided where required for splice access. Bottom pan shall have filtered breathers for outdoor section. All steel framing and panels shall be chemically



cleaned and phosphatized prior to painting. All outdoor and indoor sections shall be painted. Bus enclosure shall be such that mating parts with termination boxes, elbows, wall seal sections, and tees shall fit properly without warping, gaping, or distortion of the enclosure or accessories. Connections between joining sections of enclosures or accessories shall be bonded by the enclosure design or by jumpers to ensure electrical continuity of the enclosure. The enclosure shall be designed to be hung from overhead (indoors) or supported from below (outdoors). The bus duct manufacturer shall supply all support hardware, hangers, and pedestals.

### **8.11.3 Bus Conductors**

Bus conductors shall be multiple flat bar copper with silver plating at connections with flame-retardant, track-resistant insulation, mounted on insulated supports. Bar size and quantity per phase shall be such that the continuous current rating specified shall not cause bar temperature rise exceeding 65°C above a 40°C ambient. Bars shall be insulated with "Noryl" sleeving or dipped with a fluidized bed epoxy coating. Bars shall be mounted within the housing with flame retardant, molded, reinforced fiberglass supports. Bars shall be braced to withstand the available fault currents specified. Splice points shall use bolted connections that are accessible after installation for inspection. Splices shall be fully insulated after installation with flame retardant PVC boots or flame retardant insulating tape and jacketing tape.

## **8.12 BATTERY/UPS SYSTEM**

This section covers furnishing a generating station unit battery complete with charging system. Additionally, this section covers the furnishing of power conversion switching and distribution equipment for continuous supply of electric power to critical AC loads.

### **8.12.1 Codes and Standards**

All equipment furnished under these specifications shall conform to applicable standards of IEEE, ANSI, and NEMA. All materials and devices shall be in accordance with the applicable requirements of the Federal "Occupational Safety and Health Standards." The latest edition of each code and standard shall apply.

### **8.12.2 Design and Construction**

Each battery cell shall be wet cell, lead-acid pasted plate-type with lead-calcium alloy plate grids or sealed type with 20-year expected life. Cell containers shall be sealed, clear, shock absorbing, heat resistant plastic, with electrolyte high and low-level markers and spray-proof vents. Batteries shall be manufactured for full float service with a high discharge rate, low deterioration rate, and low maintenance. Batteries shall be supplied complete with all accessories (e.g. battery rack, inter-cell connectors). Racks shall be a 2 step configuration. Battery shall be installed in protected room ventilated with conditioned air. Battery shall have a final discharge voltage of 1.75 volts per cell and a design temperature of 30° C.

The DC power supply equipment shall include one battery (number of cells as required) of required voltage to provide 125-volt DC power for plant switchgear control power, protective relaying, steam turbine loads, and to the essential service AC system; two redundant ferro-resonant battery chargers for each battery; DC switchboard, and DC panelboards as required. The equipment shall supply DC power in emergencies to protect power plant equipment (UPS) and to ensure the safety of operating personnel.

The equipment shall provide power to trip circuit breakers, to energize emergency bearing oil pumps, emergency lighting, continuous AC power supply equipment, and critical control and protection systems. Each CTG is supplied with its own dedicated DC power system for combustion turbine DC loads.

The DC switchboard and panelboards shall have a main bus current rating as required to supply the connected load. The continuous current ratings and interrupting ratings of the feeder breakers shall be based on the available fault current and the characteristics of the connected loads or the battery chargers. Each panelboard shall include the feeder breakers required to supply the connected loads plus six two-pole feeder breakers for future use. Switchboard shall include bus voltmeter, battery ammeter with shunt, ground detection and alarm, and low voltage alarm.

### **8.12.3 Rating**

Contractor, in accordance with IEEE 485 and these Specifications, shall determine the capacity of each battery. With the actual discharge capacity of the battery at 80% of rated discharge capacity, with the battery initially fully charged at the floating voltage specified, and with the battery chargers disconnected, the battery shall be capable of supplying the duty cycle specified. The ambient temperature during the duty cycle shall be 30° C. An aging factor of 25% and design margin of 20% shall be used. Contractor shall submit battery calculations for approval.

### **8.12.4 Duty Cycle**

The batteries shall be sized to safely shut down the plant under emergency conditions without a source of auxiliary power or station service power. The station battery shall also have adequate capacity to supply emergency lighting, continuous AC power supply equipment, and critical control and protection systems for a period of three-hours following an emergency shutdown.

### **8.12.5 Battery Charger Requirements**

Each battery charger-eliminator furnished shall be self-regulating, natural cooled, solid-state silicon controlled full wave rectifier type designed for single and parallel operation with the batteries specified under these Specifications. The parallel operation features of the battery chargers shall include cross-compensation providing for equal sharing of the charger loads. Chargers shall be able to provide the DC load requirements in the event that batteries are disconnected. The chargers will be served from a 480 volt, 3-phase, 60 hertz system.

The battery chargers shall maintain output voltage within plus or minus ½% from no load to full load, with an input power supply deviation in voltage level of plus or minus 10% and an input power supply deviation in frequency of plus or minus 5%.

Solid-state electronic circuits shall have AC and DC transient voltage protection and shall be designed to recharge a totally discharged battery without overloading and without causing interrupting operation of AC or DC circuit breakers.

Redundant chargers shall be provided for each battery. Charger shall be a full capacity charger. Each charger shall have the capacity to recharge the battery in 8 hours following complete discharge. Battery chargers shall also have a equalizing charge mode. Battery chargers will be self-regulating after charging levels are manually

selected. Battery chargers shall be manufactured in NEMA 1 enclosures suitable for placement in an indoor, environmentally controlled atmosphere. The battery chargers shall require only front access, and will allow either top or bottom conduit/cable entry.

### 8.12.6 UPS Equipment Requirements

The continuous AC power supply equipment includes a voltage regulator, inverter, static transfer switch, a manual bypass switch, and distribution panelboard. The equipment shall provide 120-volt AC power to essential plant control, safety, and information systems.

The equipment shall supply all plant essential loads that would be affected by a loss of power of more than 1/4 cycle and excessive voltage and frequency deviations. The equipment shall be rated so that one inverter can supply the total plant essential loads plus 10% for future expansion. The distribution panelboard shall have a main bus current rating as required to supply the connected loads plus six single-pole switches for future use. The ratings of the fuses shall be coordinated with the characteristics of the loads and the capabilities of the inverter. In addition to the plant loads furnished by this Contract, Contractor shall include critical AC loads for the combustion and steam turbine including HMI's, hydrogen control panel, fuel gas regulator station, communication equipment, SCADA RTU's, and other critical loads determined during design.

The following equipment shall be designed and assembled to provide 120 volt, single-phase, 60 hertz power to a 2-wire uninterruptible AC power system;

- 1 Static Inverter
- 1 Full Capacity Static Switch
- 1 120 Volt AC Distribution Panelboard
- 1 Manual Bypass Switch
- 1 Voltage Regulating Transformer

All equipment, enclosures, and accessories shall be designed, arranged, assembled, and connected in accordance with the requirements of these Specifications.

#### 8.12.6.1 Static Inverter

The static inverter shall be solid-state type employing silicon controlled rectifiers and other required solid-state devices to convert direct current power to essentially sinusoidal alternating current power, and shall conform to the following characteristics and requirements:

Voltage	
Output	120 volts, single-phase, 60 hertz
Input (battery)	105 to 140 volts DC
Harmonic Distortion	Not more than 5%, 0 to 100% load
Voltage Regulation	Not more than plus or minus 2% at 0 to 100% percent load, 1 .0 to 0.8 power factor, 105 to 140 volts DC Input
Output, Self-Regulated	Automatic, not more than plus or minus 0.5% 0 to 100% load
Efficiency	Not less than 80% at rated load and 1.0 power factor
Duty	Continuous

Cooling	Natural convection or forced air cooling
Ambient Temperature	0-50°C maximum, 35°C normal
Minimum SCR Derating	50% from peak voltage and peak current ratings

#### 8.12.6.2 Inverter Capacity

The static inverter shall have the following minimum capabilities:

Continuous Full Load Rating	The inverter shall be sized to supply power for 110% of the Plant's critical 120-volt AC loads with 125% overload capability for 10 minutes.
Step Load Pickup	Upon transfer of full load, the inverter output voltage shall not drop below 75% of nominal voltage during the first half cycle after transfer and 90% of nominal voltage subsequently.
Fuse Clearing	Upon a fault in any branch circuit lateral feeder, the inverter shall have the capacity to carry a load equal to one-half of its full load rating and clear a 30-ampere, fast-acting fuse in 4 milliseconds (1 /4 cycle) or less. This requirement shall be met if the static switch fails to transfer from the inverter to the alternate source.

#### 8.12.6.3 Static Transfer Switch

The static transfer switch shall use silicon-controlled rectifiers and other static devices required to automatically transfer loads from the "Normal" source to the "Alternate" source. The static transfer switch shall conform to the following requirements:

Capacity, continuous	Equal to the continuous full load capacity of the inverter
Capacity, peak	1,000 percent of continuous rating for 5 cycles
Voltage	120 volts, single-phase
Frequency	60 hertz
Transfer time sensing,	Including 1/4 cycle maximum. Transition shall be "make before break." Voltage failure shall be sensed on the output of the static switch. Failure shall cause the static switch to transfer. The static switch shall also transfer on over-current prior to the inverter reaching a current limit mode.
Voltage transfer to "Alternate" source	Automatic transfer to alternate source When output voltage of inverter deviates plus or minus 10 percent from nominal
Over-current transfer to "Alternate" source	Continuously adjustable from inverter Continuous rating to inverter current limit rating
Retransfer to "Normal"	Return to normal shall be automatic for all source externally caused transfers such as overload or clearing of a branch circuit fuse, but shall be manual for all internally caused transfers such as inverter, filter, or normal patch failure.

Overload	125 percent for 2 minutes
Line voltage transient	170-volt peak above normal line voltage tolerance
Ambient temperature	0-50°C maximum, 35°C normal
Cooling	Natural convection or forced air cooling
Duty rating	125% Continuous

The static switch shall be provided with protective fuses in both "Normal" and "Alternate" power sources. The static transfer switch shall be furnished mounted in enclosures described later in these Specifications.

#### 8.12.6.4 Manual Bypass Switch

A manual bypass switch shall be used to isolate a static switch from its load and alternate power supply and to take it out of service without power interruption to the load. In so doing, it will connect the load bus to the alternate source. It shall have make-before-break contacts, so that power supply to the loads is continuous during switch operations. It shall be rated 600 volts, single-phase, 60-hertz, and shall have a continuous rating 125% of output rating.

#### **8.12.7 Distribution Panelboards**

Panelboards for distribution of continuous AC power to essential loads shall be dead-front type panelboards rated 120 volts AC. The hinged panelboard front shall cover the fuses and wiring gutter, but not the switch handles. The enclosure door shall cover the hinged front and switch handles.

Each panelboard shall be constructed for a 2-wire, single-phase distribution with a solid neutral bar. Phase and neutral bars shall be copper. Rating of the main lugs shall be equal to the rated continuous full-load current of the inverter.

Each panelboard shall have sufficient quantity single-pole, branch circuit protective devices to serve all loads plus 25% spare. Circuit protective device sizes required will be determined by Contractor.

Circuit identification labels or tags shall be provided on the panelboard front.

#### **8.12.8 Construction Details**

Details of construction shall conform to the requirements of the following paragraphs.

Enclosures shall be ventilated switchboard type, fabricated from not less than 14 USS gage sheet steel. Enclosures shall be designed to permit easy access to all components for maintenance or replacement. The enclosures shall be reinforced with formed steel members as required to form a rigid self-supporting structure. Doors shall have three-point latches.

Adequate ventilating louvers and openings and enclosure top panels shall be included. All vent openings shall be covered with corrosion resistant fine screen coverings.

If the equipment supplied requires forced air cooling, the cooling system furnished shall meet the following requirements.

1. Reserve cooling equipment shall be furnished for each switchboard assembly. Reserve fan capacity shall be equal to 100% of cooling fan requirements for full-load operation at the specified maximum ambient temperature.
2. Completely independent duplicate wiring and control systems shall be provided for the normal cooling fan system and the reserve cooling fan system.
3. Each cooling fan shall normally run continuously and shall be powered from the output of the inverter. Each cooling fan supply circuit shall be separately fused.
4. Each cooling fan shall be equipped with an airflow switch having an alarm contact that closes upon failure of airflow.

## **8.13 EMERGENCY DIESEL GENERATOR**

### **8.13.1 General**

Furnish and install an outdoor self-contained integrally assembled low-emission emergency diesel generator system to automatically start and energize critical busses in the event of loss of station power. Critical loads include loads to keep combustion turbine in the ready to start condition, battery chargers, turning gear, seal oil pumps, lube oil pumps, emergency lighting, and other loads as developed during the design phase.

### **8.13.2 Design and Operation**

Unit shall be designed for No. 2 fuel oil with an integral day tank for 18 hours operation before filling. Heaters shall be provided to maintain water temperature to allow unit to be brought to full load within 30 seconds of starting. Provide day tank fuel oil heaters if required due to low ambient temperatures. Provide local panel for control and monitoring of unit. Unit shall be capable of remote control from the plant distributed control system. Unit shall be capable of automatic starting and synchronizing to hot or dead bus. Include any required fire protection equipment.

## **8.14 ELECTRIC MOTORS**

Except for valve motor operators (specified elsewhere), these motor specifications are applicable to all electric motors furnished under these Specifications. Special requirements for individual motors and specifications for special application motors are included in the equipment technical sections, as required. All motors shall be Premium Efficiency.

All motors shall conform to applicable standards of ANSI, IEEE, NEMA, and AFBMA, except where modified or supplemented by these specifications. All equipment and materials shall be in accordance with the applicable requirements of the Federal "Occupational Safety and Health Standards." The latest edition of these codes and standards shall apply.

The motor nameplate horsepower multiplied by the motor nameplate service factor shall be at least 15% greater than the driven equipment operating range maximum brake horsepower. Motor ratings shall be based on site maximum design ambient temperature. Any motors used in variable frequency applications, such as air-cooled condenser fans, shall be rated for the application and type of drive.

Motors shall be designed for full voltage starting and frequent starting where required, and shall be suitable for continuous duty in the specified ambient. Intermittent duty motors may be furnished where recognized and defined as standard by the equipment codes and standards. Motors shall be sized for the altitude and temperature range at which the equipment will be installed.

Except as specified otherwise in the individual paragraphs or technical sections, the torque characteristics of all induction motors at any voltage from 90% rated voltage to 110% rated voltage shall be as required to accelerate the inertia loads of the motor and driven equipment to full speed without damage to the motor or the equipment.

#### **8.14.1 4000 and 460 Volt Integral Horsepower Motors**

Motors  $\frac{3}{4}$ - hp to 200-hp shall be rated 460-volt, 3-phase, 60-hertz. Motors 250-hp and greater shall be rated 4000 volt, 3-phase, 60-hertz. Design and construction of each 460-volt integral horsepower motor shall be coordinated with the driven equipment requirements and shall be as specified herein. Any exceptions shall be approved by Owner.

The following nameplate data shall be included:

1. Starting limitations, if any.
2. AFBMA bearing identification number for motors furnished with rolling element bearings.

For motors designed for service in hazardous areas:

1. Location class and group design.
2. Maximum operating temperature value or operating temperature code number.
3. All other motor data such as horsepower, FLA, service factor and related items.
4. All motor nameplates and attachment pins shall be corrosion-resistant metal.

All motors shall be self-ventilated unless required otherwise. Enclosure parts for all motors (e.g., frames, bearing brackets, external fan covers) shall be made of cast iron, cast steel, sheet steel, or steel plates. Aluminum enclosure parts are not acceptable. All open-type motors and the fan covers of totally enclosed fan-cooled motors shall meet NEMA MG 1 requirements for a fully guarded machine.

Totally enclosed motors shall be furnished with drain holes and rotating shaft seals. Drain holes shall be provided with Crouse-Hinds Type ECD "Universal" combination water drain-breather plugs, or approved equal. Motors for outdoor service shall have all exposed metal surfaces protected with a corrosion-resistant polyester paint or coating.

In addition to the preceding requirements for outdoor service motors, totally enclosed motors with NEMA waterproof features shall have enclosure interior surfaces and the stator and rotor air gap surfaces protected with corrosion-resistant alkyd enamel or with polyester or epoxy paint or coating. Bolts, nuts, screws, and other hardware items shall be corrosion-resistant or heavy cadmium-plated metal. A rotating labyrinth shaft seal shall be furnished on the shaft extension end of the motor. Motors specified for Class I, Group D locations shall be UL approved and labeled.

Except as specified in the following paragraph, all insulated windings shall have Class F Non-hygroscopic insulation systems limited to class B rise. Motors larger than 200 hp shall be provided with sealed insulation systems and be abrasion resistant for any open motors.

All insulated winding conductors shall be copper. The winding temperature rise for all motors, when operating at the nameplate horsepower multiplied by the service factor shall not exceed 80°C. Motors larger than 200 hp shall have 2 embedded RTD's per phase.

All motors furnished in NEMA 180 Frame Series or larger shall have space heaters. Space heaters shall be rated a 120 volts, single-phase, 60 hertz. Space heaters shall be sized as required to maintain the motor internal temperature above the dew point when the motor is idle. The space heaters shall not cause winding temperatures to exceed rated limiting values, nor cause thermal protective device "over temperature" indication when the motor is not energized.

Terminal housings for totally enclosed motors shall be cast iron. Terminal housings for all other motors shall be cast iron, pressed steel, or fabricated steel. Housings shall be diagonally or longitudinally split with a gasket between the split halves of the housing. Each housing shall have a threaded opening to provide a watertight, rigid connection with the conduit, and shall be designed for rotation in 90-degree increments, or have other provisions to receive conduit from any of four directions

All leads shall be wired into the motor terminal housing. All leads and their terminals shall be permanently marked in accordance with the requirements of NEMA MG 1, Part 2. Cable-type leads shall be provided with compression-type terminal connectors. Motors 2500 hp and larger shall be provided with surge protection and current transformers for motor differential protection.

Each motor shall be furnished with a grounding connector attached to the motor frame inside the motor terminal housing. The grounding connector may be a lug or terminal or other acceptable grounding connector. Motors larger than 200 hp shall have grounding pad on frame for connection to plant ground grid.

Antifriction radial and thrust bearings shall be designed and fabricated in accordance with AFBMA standards to have a minimum:  $L_{10}$  rating life of not less than 130,000 hours for direct coupled service, and not less than 42,500 hours for belt or chain connected service. Grease lubricated radial bearings shall be double-shielded.

Oil ring lubricated-type sleeve bearings shall be provided with oil level sight glasses marked for required oil level at motor running and motor standstill. The oil ring shall be one-piece construction; split-type construction will not be acceptable. Stationary labyrinth seals shall be bronze material.

Sleeve bearings, end bells, and bearing housings for horizontal motors shall be split-type when available for the frame and the enclosure specified. Air gap measurement holes or other acceptable means will be provided in each motor end enclosure for checking air gap of sleeve bearing motors.



Sleeve bearings on horizontal motors shall be designed and located centrally, with respect to the running magnetic center, to prevent the rotor axial thrust from being continuously applied against either end of the bearings. The motors shall be capable of withstanding without abnormal damage the axial thrusts that are developed when the motor is energized.

Motors furnished with spherical roller thrust bearings shall also be furnished with deep groove radial guide bearings. One guide bearing shall be locked to the shaft so that the guide bearing will take upward thrust and to assure that the thrust bearing is always loaded. If spring loading is furnished, the guide bearing shall not be preloaded during normal operation.

Thrust bearings for vertical motors shall be capable of operating for extended periods of time at any of the thrust loading imposed by the specific piece of driven equipment during starting and normal operation without damage to the bearing, the motor frame, or other motor parts.

Stacked antifriction bearings will not be acceptable, except as vertical thrust bearings in frame sizes up through NEMA 360 Series open-type enclosures and up through NEMA 680 Series open-type enclosures. Where stacked bearings are furnished, matched pair precision tolerance bearings with flush ground sides shall be provided. Bearing seats on the shaft and in the bearing housing shall have accuracy equal to that of the bearing. Grease lubricated bearings shall be self-lubrication and re-greaseable.

Bearings and bearing housings shall be designed to permit disassembly in the field for inspection of the bearings or removal of the rotor. Bearing lubricants shall contain a corrosion inhibitor. Contractor shall furnish all lubrication information required to assure proper equipment startup and subsequent bearing maintenance. All induction motors shall have squirrel-cage rotors.

Where shipment permits, motor output shafts shall be complete with motor half-coupling mounted, connected to the driven equipment, and adjusted ready for operation. Where motor size prevents shipment with motor connected to driven equipment, the motor half-coupling shall be factory-mounted for field connection to the driven equipment.

Motors shall have torque and locked rotor current in accordance with NEMA MG 1, Part 12 and sufficient to meet starting requirements of loads.

The maximum motor sound level shall be 85 dBA.

#### **8.14.2 Fractional Horsepower Motors**

Motors rated less than ¾-hp shall be rated 115-volt, single-phase, 60-hertz except for valve or damper operators. Motor rating, service factor, and nameplate data shall conform to the requirements of NEMA MG 1 standards.

Motor nameplate horsepower ratings shall not be exceeded when the equipment is operating within the limits of the design conditions specified. The motor loading shall not exceed the motor service factor rating on startup conditions or at the equipment maximum load point.

All motors shall be self-ventilated. Fully guarded enclosures shall be furnished on all motor enclosure types having accessible moving parts other than shafts. All insulated winding conductors shall be copper. Shafts of motors shall be furnished with corrosion-resistant treatment or shall be of corrosion-resistant metal.

Capacitors, as required, shall be furnished in removable metal enclosures mounted on the motor frame. Lock washers shall be provided under the heads of the enclosure hold-down bolts.

Manual reset thermal protection, for both stalled rotor and overload protection, shall be furnished on all motors where available unless specified otherwise in the individual technical sections. All motors shall be completely assembled with the driven equipment, lubricated, and ready for operation.

### **8.15 RACEWAY**

This section covers furnishing and field installation of a complete raceway system in accordance with these specifications.

The raceway system is defined to include conduit, flexible conduit, continuous rigid cable supports called "cable tray" herein, underground duct, wireway, cabinets and boxes, and all materials and devices required to install, support, secure, and provide a complete system for support and protection of electrical conductors.

The design and specifications for the raceway system used in supporting and protecting electrical cable shall be in accordance with the provisions of the NEC. Fire stops shall be provided wherever raceways penetrate floors or fire rated walls.

Individual raceway systems shall be established for the following services:

1. 4160 volt power.
2. 480 volt and 125 vdc power.
3. 600 volt control cable.
4. Special electrical noise-sensitive circuits or instrumentation cable.
5. Lighting
6. Fiber optic

Lighting branch circuits, telephone circuits, fiber optic cables, and intercommunication circuits shall be routed in separate conduit systems. Lighting circuits shall be routed in electrical metallic tubing (EMT) for indoor concealed areas, rigid conduit for hazardous exposed and outdoor areas, and polyethylene (PVC) tubing or Schedule 40 PVC conduit for underground.

Hot dipped galvanized conduit (after fabrication) shall be used for above ground power control wiring except at the cooling tower. Fiberglass or aluminum tray and conduit shall be used beneath the cooling tower fan deck and other corrosive areas.

Rigid galvanized steel conduit shall be used for routing individual circuits from the cable tray system to individual devices and pieces of equipment. Liquid-tight flexible conduits shall be used on all motor connections and all other connections subject to vibration.

All underground duct banks shall consist of Schedule 40 PVC conduit encased in concrete. Duct banks shall be reinforced at road crossings and areas subject to heavy loads. Duct banks shall have red dye incorporated in the top two inches of concrete. Galvanized steel conduit shall also be installed for digital and analog low level circuits to provide noise immunity from adjacent power circuits if required. Risers shall be concrete encased conduit. Spare ducts shall be provided in each duct bank run equal to 20% of the total number of ducts with the size of the spare ducts equal to the largest size duct in the duct bank. Duct banks shall be sloped to provide proper drainage.

Duct banks shall be assembled using non-magnetic saddles, spacers and separators as recommended by the duct manufacturer. Separators shall provide 3 inches minimum concrete between the outer surfaces of the conduits.

Duct bank routes shall be identified at 100 feet (minimum) intervals by means of a 4 inches x 4 inches concrete marker set flush with grade and with the letter "E" and an arrow cast in the top. Markers should be approximately 3 feet in length and shall be placed at the side of the duct bank to prevent puncturing of ducts if marker is run over by a vehicle.

Reinforced concrete manholes shall be provided, where required, so that cable may be installed without exceeding allowable pulling tensions and cable side wall pressures. Each manhole shall have the following provisions:

1. Provisions for attachment of cable pulling devices.
2. Provisions for racking of cables.
3. Manhole covers of sufficient size to loop feed the largest diameter cable through the manhole without splicing.
4. Sealed bottoms and sumps.

The installation specifications included in this article apply to all raceway system components.

#### **8.15.1 Routing of Above Grade Raceway and Conduit**

Contractor shall route raceway and conduit and shall coordinate conduit locations with other equipment and structures. Raceway and conduit shall be routed so that, except where they are being lowered to enter equipment, the lowest part of the raceway or conduit, including its associated supports and appurtenances, is at least 6'-8" above the closest floor or walking surface beneath it. Raceway and conduit may be routed a reasonable distance away from the supporting wall, ceiling, or structural member so long as the specified support is provided, interference with other equipment and structures is avoided, and the routing is acceptable to Owner. Raceway and conduit, including their associated supports and appurtenances, which must be routed closer than 6'-8" above the closest walking surface beneath it, shall be routed as close as possible to surfaces of walls, columns, and the equipment served. Conduit supports shall be spaced no longer than 10 feet. All junction, terminal, and pull boxes shall have construction suitable for the environment and area classification. Expansion couplings are required for every 100 foot.

All raceway and conduit shall be installed in a neat, rectangular form. Special attention shall be given to securing a neat appearance. All raceway and conduit shall be installed

perpendicular or parallel to the major equipment, building structure, and floor levels, except in special cases consented to by Owner.

### **8.15.2 Electrical Cable Tray System**

An electrical cable tray system shall be furnished and installed in accordance with these Specifications. The electrical cable tray shall be in accordance with the requirements of NEMA VE 1 except that, in case of conflict between the requirements of these Specifications and the requirements of NEMA VE1, the requirements of the latter shall govern to the extent of such conflict. Tray shall be installed in a continuous system. In addition to and concurrent with the load specified in this section, the tray shall be designed to withstand a concentrated load of 200 pounds at the mid-span, at the center of the rung or on either side rail.

Cable trays shall be of ladder-type construction with a rung spacing of 6 to 9 inches, nominal depths of 4 to 6 inches, and various widths as required. Cable trays shall be supported in accordance with NEMA VE-1 standards.

Cable tray shall be labeled with the tray type and node designations shown on Contractor's drawings. Labels shall be of the adhesive type and shall be applied to both sides of each tray at the locations shown on Contractor's Drawings. Letters and numbers on the labels shall be minimum of two inches in height and shall be colored as follows:

1. Power Tray: Black characters on red background
2. Control Tray: Black characters on yellow background
3. Instrumentation Tray: Black characters on green background

Cable trays and fittings shall be the standardized products of a single manufacturer designed to permit easy assembly in the field. The parts shall consist of the manufacturer's standard straight sections, crosses, tees, reducers, flat and riser elbows, as required to suit the layout. Coupling between the members shall be manufacturer's standard. All fittings shall be designed and constructed so that (1) the assembled system will be free of sharp edges or projections on surfaces which contact the cables, and (2) the cables will not be bent, either during installation or in the final position to radii less than allowable for each respective size and type. Dropout fittings shall be provided where required to maintain the minimum cable-bending radius. Where warranted, Contractor may use tray dividers for different class cables. The fill of each of the respective sections shall not exceed NEC limits.

Solid bottom trays shall be provided for all special noise-sensitive circuits and analog instrumentation circuits. Instrumentation trays shall be of steel solid bottom trough tray, galvanized after fabrication. All instrumentation trays shall have complete coverage with solid tray covers. Standard ladder type tray without tray covers may be utilized for instrumentation circuits if this installation method and separation criteria is acceptable to equipment vendors. In any case, shielded, twisted pairs shall be utilized for all low level signals.

All trays shall be of steel construction, width and depth as required for application. All trays shall be designed with a safety factor of 2.0.

### 8.15.3 Covers

Except as specified otherwise herein, all indoor vertical trough and ladder-type trays shall be furnished with ventilated covers to provide mechanical protection to cables which are exposed to traffic. All indoor horizontal trays located under grating floor or insulated pipe shall be furnished with covers which, on trough and ladder-type trays, extend at least two feet beyond that part of the trays directly exposed beneath the grating floor or insulated pipe. Indoors, covers may be omitted on those lower trays of stacked trough and ladder-type trays where a covered tray at a higher elevation in the stack provides complete vertical shielding to the lower tray. The top level of outdoor tray runs shall be furnished with covers. Trays which are specified to have solid bottoms shall also have solid covers throughout including all horizontal runs, all fittings, and all vertical runs.

### 8.15.4 Tray Supports

Tray supports shall be furnished and installed in accordance with these Specifications. Contractor shall be responsible for designing the cable tray support system within the allowable limits specified by the manufacturer of the support hardware.

Each support shall be capable of supporting the uniform weight of the trays, plus their nominal uniform cable loads, plus a 200-pound concentrated load without exceeding the allowable limit of any element of the support system. The safety factor of support hardware shall not be considered in determining the suitability of any element, except that the safety factor shall not be less than 2.0 for any support element.

Hanger rods shall not be smaller than 1/2-inch diameter electro-galvanized threaded steel rods.

### 8.15.5 Material

Underground duct system materials furnished under these Specifications shall be new and undamaged and shall conform to the following requirements:

Duct	Polyvinyl chloride, Schedule 40 PVC in accordance with NEMA TC-2.
Couplings	Plastic, for use with duct previously specified and "Duct-to-steel" adapters as required, including joint cement.
Spacers	Plastic high impact, interlocking, base and intermediate type
Factory bends and sweeps	Schedule 40 PVC, 36 inch minimum radius
End bells	Plastic
Plugs	Plastic, high impact, tapered to fit end bell provided
Duct binder	Hemp or sisal twine coupling
Riser termination	Rigid hot-dip galvanized mild steel coupling
Riser bends	Rigid steel conduit elbows, factory or field made, 36-inch minimum radius, 90 degree, entirely concrete encased below grade; hot-dip galvanized rigid mild steel in accordance with ANSI C80.1 and UL 6; the conduit interior and exterior surfaces having a continuous zinc coating with an overcoat of transparent enamel or

## 8.16 CONDUCTORS

In general, conductors shall be insulated on the basis of a normal maximum conductor temperature of 90°C in 40°C ambient air with a maximum emergency overload temperature of 130°C and a short-circuit temperature of 250°C for medium voltage cables and 75°C for 600 volt cables. Power conductor size and ampacity shall be coordinated with circuit protection devices. Conductor minimum size shall be the largest conductor of the following:

1. Applicable standards
2. Maximum ambient temperature
3. 125 % of connected load
4. For bus feeders 100 % of connected load plus 25 % of running load.
5. 90% minimum motor terminal voltage on starting (except if motor is designed for lower terminal voltage)
6. Voltage drop from no load to full load for switchgear and MCC's excluding transformer drop per NEC.
7. Computerized thermal model of cable position in duct bank (30°C average soil temperature).
8. Cable temperature rise due to short circuit.
9. Worst environmental condition when routed through multiple areas.

Insulated cable, conductors, and conductor accessories shall be furnished and installed in accordance with the requirements of this section of these Specifications. Insulated cable, conductors, and conductor accessories shall be furnished in quantities sufficient for a complete installation as indicated in these Specifications.

Installation shall be defined to include placement, splicing, terminating conductors; coiling and taping of spare conductors; identification, testing, and verification of each circuit, cable, and conductor. Installation of cable in trays shall also include removal and replacement of cable tray covers. Installation shall be in accordance with manufacturer's requirements. Manufacturer's pulling or side wall tension shall never be exceeded. Contractor shall submit recorded cable tension reports. Cable shall be supported by conduits or tray for any cable routed over tray side wall. Any bottom exit cables shall be shall have suitable fittings. Cable in vertical tray risers shall be supported every 2 feet or less to prevent stress on cable.

Terminating a conductor shall include installing cable termination kits for shielded cable, attaching the conductor at its designated location, and insulating the entire connection where specified or required by the application.

### 8.16.1 Cable Specifications

The cable furnished shall be flame retardant construction meeting IEEE 1202 and UL 1581 and manufactured in accordance with the applicable ICEA standards and suitable for wet or dry locations. All cable installed in trays shall be rated for tray use. All cable shall have surface printing showing manufacture's name, insulation type, jacket type, conductor size, conductor type, voltage rating, and numbered footage markers. Control and instrument cables shall be terminated with ring tongue connectors. Compression

type terminals may be utilized if this is the manufacturer's only offering. Special construction cables as required to meet equipment supplier requirements (turbine-generator) shall meet the following requirements to the extent possible in addition to meeting supplier requirements. Control, metering, and relaying cables routed to the switchyard shall have construction as follows except cable is to be shielded.

The cable furnished shall conform to the cable descriptions included below:

<b>CABLE TYPE</b>	<b>DESCRIPTION</b>
Medium Voltage Power	25,000 and 5,000 volts, single-conductor and three conductor with ground, Class B stranded copper, ethylene propylene rubber (EPR) 133% insulation, conductor, insulation and tape shield; and chlorosulfonated polyethylene (CSP), polyvinyl chloride (PVC), or chlorinated polyethylene (CPE) jacketed. Where specified by General Electric unshielded cables are to be used.
Low Voltage Power	600 volts, single-conductor, Class B stranded copper; EPR or XLP insulated; CPS, PVC, or CPE jacketed.
Low Voltage Power	600 volts, three-conductor; concentric lay, stranded copper with a ground wire in the interstices; FRXLPE or FREPR insulation; CSP, PVC, or CPE jacketed overall.
Control	Control cable, 600 volt, multiple-conductor, as required, stranded copper, 10 AWG, 12 AWG, 14 AWG; multiple-conductor, XLP insulation; CSP, PVC, or CPE jacketed overall.
Thermocouple	Thermocouple extension cable, one, four, six, and eight twisted pairs, solid alloy conductor with the same material as the thermocouples, with shield over each pair (except for one-pair construction) and with an overall shield, 16 AWG single pair; 20 AWG multi pair; FRXLPE or FREPR insulation; aluminum mylar tape shield with drain wire; CSP or CPE jacketed overall.
High Temperature Thermocouple	High temperature thermocouple extension cable, single-twisted pair thermocouple extension cable; solid alloy conductor with the same material as the thermocouples; 20 AWG; with normal maximum operating temperature of 200° C; Teflon insulation; aluminum mylar tape shield with drain wire; Teflon jacketed overall.
Instrumentation	Instrumentation cable, 300 V minimum, flame retardant single-and multiple-twisted pairs and triads, shielded instrument cable with individually shielded pairs, overall shield, and overall jacket; FRXLPE or FREPR insulation; CSP, PVC, or CPE jacketed overall. (Single pair or triad 16AWG,

	multi-pair or triad 18AWG).
High Temperature Instrumentation	Same as instrumentation able above 200°C Teflon insulation and jacket.
High Temperature Fixture Wire	High temperature control and fixture wire, single-conductor control cable; stranded copper; 12 AWG; stranded copper, with normal maximum operating temperature of 200°C; silicone rubber insulation; braided glass jacket.
Lighting & Receptacles	Lighting circuit runs totally enclosed in conduit, NEC Type RHH-RHW-USE with XLPE insulation for use in outdoor or unheated areas.

### 8.17 GROUNDING

This section covers the furnishing and installation of grounding materials complete as specified herein.

The station grounding system shall be an interconnected continuous network of bare copper conductor and copper-clad ground rods (ground wells maybe used instead of ground rods if dictated by the soil analysis). The system shall be designed to protect plant personnel and equipment from the hazards that can occur during power system faults and lightning strikes. Contractor shall perform ground resistivity testing prior to final design to determine ground analysis parameters. Ground system design will include switchyard extension, switchyard, and incoming lines in the development of the ground model. The grounding system shall be designed to ANSI/IEEE standard 80, 142, and 665 and NEC Sec. 96A.

The station grounding grid shall be designed for adequate capacity to dissipate heat from ground current under the most severe conditions in areas of high ground fault current concentrations, with grid spacing such that safe voltage gradients are maintained. Ground cable shall be sized for a fault duration of 0.5 seconds. The ground system shall be designed to have a resistance to ground of 1 ohms or less. Upon completion of ground system installation, perform ground system testing to verify design.

Bare conductors to be installed below grade shall be spaced in a grid pattern. Each junction of the grid will be bonded together by an exothermal welding process.

Grounding risers shall be connected to the building steel, fences, and equipment. Equipment grounds shall conform to the following general guidelines:

1. Grounds shall conform to the NEC and NESC.
2. Major items such as generators, switchgear, secondary unit substations, motor control centers, relay panels, medium voltage motors, and control panels shall have integral ground buses, which shall be connected to the station ground grid.
3. Electronic panels and equipment shall be grounded utilizing an insulated ground wire connected in accordance with the manufacturer's recommendations. In some situations, a separate small grid and ground rod, isolated from the main ground, may be required by the vendor. Where practical, electronics ground



loops shall be avoided. Where this is not practical, isolation transformers shall be furnished.

4. Ground conductors will be sized in accordance with the NEC.
5. All single conductor ground wires installed in conduit shall be insulated. Ground conductors included in a multi-conductor power cable may be uninsulated.
6. Grid extended to 4 feet on the inside and outside of the fence line with connections to any access gates. Fence to be grounded at points no greater than 40 feet with ground rods driven at that point. Risers shall be #4 connected to fence fabric.
7. All electrical raceways to be grounded to main grid system.

Remote buildings and outlying areas with electrical equipment shall be grounded by establishing local sub-grade ground grids and equipment grounding systems in a manner similar to the plant area. Remote grids shall be interconnected with the station ground grid to reduce the hazard of transferring large fault potentials to the remote area through interconnecting instrumentation and communication cable shields.

### 8.17.1 Ground Grid Design

The final conductor sizing, grid configuration, grid depth, grid spacing, and quantities of conductor for the grid is to be determined during detailed design. Ground resistance shall be equal or less than one (1) ohm as confirmed through final ground grid design and testing (as defined above). Site specific soil resistivity studies are required to firm up this design. Specialized ground system software will be utilized for the final design.

#### Materials

All grounding materials required shall be furnished new and undamaged in accordance with the following requirements:

Rods	¾ inch 10-foot copper-clad standard type. The copper cladding shall be electrolytically bonded to the steel rod or bonded by a molten welding process. Cold rolled copper cladding is not acceptable. Ground rods shall be as manufactured by Blackburn, Weaver, or Owner-approved equal.
Cable	
Bare	Soft drawn copper, Class B stranding, ASTM BB
Insulated	Soft drawn copper, Class B stranding with green colored polyvinyl chloride insulation, UL 83, Type TW, THW, or THHN.
Wire Mesh	Copper-clad, 6 AWG, 6 inch by 6 inch mesh spacing, copper weld or Owner-approved equal.
Bus and Bars	Soft copper, cross section not less than 1/8 inch thick by 1 inch wide, ASTM 8187.
Exothermall Welds	Molds, cartridges, materials, and accessories as recommended by the manufacturer of the molds for the items to be welded. Cadweld heavy duty or Owner-approved equal. Molds and powder shall be furnished by the same manufacturer.
Flush ground plates	Cadweld B-162 Series, B-164 Series, or Owner-approved equal ground plates with NEMA hole spacing.

All clamps, connectors, bolts, washers, nuts, and other hardware used with the grounding system shall be of copper.

#### **8.18 PLANT SECURITY SYSTEM**

Contractor shall install raceway, power cable, and fiber optic cable to each of the plant fence corners, main entrance gate, and contractor turnstile gate. The cables shall be routed to an area designated by Owner in the control room for connection to Owner furnished security system.

#### **8.19 ELECTRICAL TESTING**

Contractor shall perform detailed testing for all equipment, materials, and systems furnished under this Contract. Equipment shall be tested in accordance with manufacturer's instructions and NETA (National Electrical Testing Association - Acceptance Testing Specifications for Electric Power Distribution Equipment and Systems) requirements. In addition to equipment tests, Contractor shall perform functional tests to verify proper operation and interlocks of equipment. Any procedures that may affect the existing plant shall be coordinated with Owner.

Contractor shall prepare detailed written step-by-step procedures for major electrical functional tests such as back-feed and synchronization. Procedures shall include predicted values as well as actual measured values. These procedures shall be submitted to Owner for review and comment. Prior to the start of any of these major tests, all associated parties shall sign-off on the procedure.

Contractor shall prepare a hardbound notebook with copies of the testing reports. In addition CD's shall be prepared with electronic copies of the reports plus any manuals, software, or reference material used in the plant testing. Owner may choose to witness some tests. Prior to start of the testing program coordinate with Owner to identify tests they may witness.

\*\*\*\*\*

## **SECTION 9.0**

### **INSTRUMENTATION AND CONTROL SCOPE**

#### **9.1 GENERAL REQUIREMENTS**

This section covers the minimum scope, technical requirements and quality standards for the combine cycle power block instrumentation, control systems, Equipment and interfaces with other plant systems and facilities. The Contractor shall provide all Materials and labor for the engineering, design, procurement, delivery, staging, installation, construction, inspection, factory testing, startup, and commissioning of all instrumentation and controls systems specified herein and necessary for a complete, functional combine cycle power generating facility and in conformance with generally accepted practices for generating facilities. All control and instrumentation design will be performed under the supervision of a Professional Engineer. In addition, all Work shall comply with applicable codes and standards identified in Section 3.0 including all State and local codes, laws, ordinances, rules and regulations.

Provide instrumentation and controls for the plant to keep the number of plant operators to a minimum while providing sufficient monitoring and control capabilities, ensuring continued safe and reliable operation of the plant, and alerting the operators to any abnormal conditions or situations requiring manual intervention in a timely manner. The facility shall be capable of operating at all normal and abnormal conditions, including hot startup with one control room operator and one outside operator. During cold startup, the plant shall be capable of operating with one control room operator and two outside operators.

The integrated control of all plant systems shall be accomplished using Distributed Control Systems (DCS) as described in this Specification.

Provide discrete, independent, and dedicated I/O racks, DCS controllers, and operator interfaces. Controllers and operator interfaces shall be networked together to provide an integrated control system. The controllers, I/O racks, raceways, and conduit shall be completely physically independent of other system. DCS, controller, communication modules, I/O racks shall be partitioned to logical arrangements.

In general, modulating controls shall be backed up by interlocks and/or safety systems which cause pre-planned actions in cases where unsafe conditions develop faster than the modulating controls or the operator can be expected to respond.

Skid mounted Programmable Logic Controllers (PLC) shall be interfaced with the DCS to provide full remote control and monitoring capabilities to the operator. Specific control and monitoring requirements for major systems are described in the Specification sections covering the systems.

All instrumentation and control equipment shall be of proven design and shall be selected to achieve the highest level of plant availability and ease of equipment

maintenance. Control and instrumentation provided shall be complete in all respects, requiring no further additions. Standardization of instrumentation and controls hardware shall be observed throughout the Project. All instruments, control valves, PLC controllers, and other control devices of a common nature shall be of the same manufacture, and wherever practical, shall be of identical model. DCS controllers shall be of identical manufacture and model. All electronic field devices shall be Smart, Highway Addressable Remote Transducer (HART) compatible.

All PLC controllers shall be located in air conditioned rooms or enclosures.

In general, local single closed loop control may be utilized for the control of systems that do not require optimization such as, for example, blowdown tank level. Individual sensors with integral or local controls, for example, direct level controllers shall be utilized for these types of loops.

Redundant components, as required by code, shall be installed as completely separate devices with individual sensing taps and individual isolation capability.

All critical sensors for continuous controls and protection shall be redundant. No control I/O signals shall be multiplexed. Indication signals may be multiplexed at the Contractor's option.

Mechanical equipment shall be provided with safety interlocks incorporated into the system controls to prevent damage to the equipment. Mechanical systems shall incorporate in their control the necessary equipment recommended by the manufacturer to assure that operational Contract conditions, as set forth by Owner, have been complied with.

Mechanical equipment on standby status shall automatically start when system conditions are beyond the parameters set for normal operation. Annunciation shall be provided whenever a "standby" piece of equipment is placed into service.

## **9.2 DISTRIBUTED CONTROL SYSTEM (DCS)**

The DCS shall be designed for automatic supervisory control of the combined cycle generation plant as well as to initiate manual commands and shall provide safe, reliable, and efficient operation of the plant.

The DCS shall include supervisory controls, plant process operation monitoring, plant operating condition indication, and display to advise operating personnel of the current operating status of the plant. During normal operation or in the event of an abnormal plant upset condition(s), the DCS shall enable the operator to take over and manually control the plant.

The DCS shall contain sufficient built-in hardware and software redundancy to include but not limited to redundant control processors, redundant data highway and power supplies with automatic changeover to the standby unit upon detection of a fault of the operating units. The failure of any single element shall not affect the operations or monitoring of the plant.

The DCS shall be utilized to the maximum extent possible for control, monitor, logging, alarm annunciation of plant equipment and the process. Features of the DCS shall include redundancy of controllers, redundancy of power supplies, operator stations, printers, and redundant communications. In addition to control capabilities, the system shall include all features required for historical data recording, data processing, and minor calculations for report generation and billing purposes. Consolidation of files shall be selectable. A minimum of thirty (34) days data storage capacity shall be provided with system to allow for downloading to a CD/DVD drive or DAT-tape drive.

Where process equipment is furnished with its own packaged controls and instruments, these devices shall be interfaced with the DCS as required to provide full data for monitoring, logging, to annunciate, and acknowledge alarm conditions, and to fully communicate DCS commands and responses to and from the packaged controls as required via redundant gateway interfaces.

A control room operator using the DCS shall be capable of supervisory control including starting, stopping, normal operation, and monitoring and acknowledging of alarms for the gas turbine generator(s) and steam turbine without physically needing to go to the GTG or STG control interfaces.

Provide first-out indication, annunciation, alarming, and sequence of event (SOE) monitoring, time stamp to 1 millisecond for each GTG and STG. Provide a GPS time stamping synchronization system or Owner approved equal for the synchronization of all system clocks.

Installation of the DCS shall be in accordance with the manufacturer's recommendations and guidelines. Installation shall take into account noise and grounding considerations. A complete power-up and grounding check shall be performed subsequent to cabinet installation and prior to beginning terminations. The Contractor shall be responsible for the application loading and debugging of all software, and for testing, calibration, startup and commissioning of the DCS and communication links with other plant systems.

Coordination of all electrical and steam generating systems with respect to one another shall be maintained and designed into the DCS controls so that a change in plant load demand shall be translated into a smooth, characterized change in demand to each affected system. The coordinated control shall recognize all limitations exhibited in these systems and shall take appropriate action.

The DCS shall be supplied with all process signals required to perform calculations and comparisons by the operator.

The plant consumption and generation of energy shall be monitored and logged in the DCS. Metering requirements are provided in Section 8. Reports shall be generated for each billing period documenting gross and net generation. These reports will be used to confirm the utility furnished metering system and may be relied on for billing in the event of a utility metering system malfunction.

Provisions shall be made for the prevention of unauthorized or accidental changes to system configuration. System data logging and recovery capability shall be provided so that control system configuration and database can be quickly restored in the event of an operator error or system failure.

The DCS shall interface with the Owner supplied PI data storage system.

The DCS shall also include the following capabilities for monitoring and controlling electrical systems within the facility, displayed on operator console graphic screen(s):

1. Control, status, and alarm indications of all high voltage circuit breaker on electrical one-line diagram.
2. Analog Input and output signals as indicated on electrical one-line diagram.
3. Control, status, and alarm indications of the emergency AC system transfer switches.
4. Status and alarm indications of uninterruptible power supply (UPS) and DC system.
5. Other analog, status, and alarm indications for complete monitoring of electrical systems and subsystems.

DCS system shall have the following as a minimum:

1. Four operator workstations for plant monitoring and control each equipped with an operator keyboard, mouse, and dual 19" CRT Flat Panel or LCD graphic displays.
2. One dedicated engineering workstation for programming modifications equipped with keyboard, mouse, and dual 19" CRT Flat Panel or LCD graphic displays.
3. Two printers, one for periodic reports and operator logging, the other for an alarm printer.
4. One color laser printer for hardcopy documentation of system configuration and color graphics.
5. 100 custom interactive P&ID graphics shall be included in the design. In addition to these displays, all control loops, indicator, and alarms will be shown on group displays depicting H/A stations and push button stations.

Provide the capability to allow all graphics and controls interface to be monitored and manipulated from any of the operator interfaces and the engineering workstation.

All software and operating systems provided shall be manufacturer's latest offering and shall comply with the design requirements, features, and capabilities specified herein.

All control room furniture and consoles provided for the Project shall be of identical manufacture and configuration. Consoles shall be provided for the operator stations, engineering station, GTG and STG Remote HMI's, CEMS stations, 5 printers, and trip panel containing GTG, STG, HRSG MFT Trip pushbuttons. The existing Block 1 combined cycle plant control room shall be expanded by Owner to incorporate the new Block 2 combined cycle plant consoles, and plant control workstations. A layout for existing Block 1 Central Control Room detailing Block 2 layout is attached in Appendix C.

### 9.3 DCS CONTROLLERS AND I/O

DCS Controllers shall be loaded to no more than 60-percent upon completion of Factory Acceptance Testing and 75-percent upon completion of commissioning. Controller cabinets shall be located throughout the plant, as required, to enhance reliability and to reduce wiring requirements.

The DCS shall be sized such that there shall be 20-percent spare's of each I/O type at each location at time of shipment to the site and 10-percent spares of each I/O type at each location at Substantial Completion, as a minimum. In addition, cabinets will be furnished with at least 10-percent spare card slots in every card cage and 20-percent extra space in each cabinet for future use.

The system will be capable of scanning, processing and storing any inputs and outputs at the rate of at least four times per second and at 1 millisecond for SOE points. Peer-to-peer communications between controllers will communicate all points at the rate of once per second. Actual scan times will meet the hardware requirements for the controller loop processing time. Overall system scan rate shall not exceed 250 milliseconds.

To permit removal of I/O modules without removing field wiring, all I/O field terminations shall be terminated on separate field termination blocks in I/O cabinets.

Analog input signals to the system will be isolated and either current limited or fused from the internal circuitry so that shorting, grounding or opening the circuit at the transmitting Equipment will not affect control system performance. Analog inputs shall not exceed 8 per card. The system shall provide quality checks for all analog inputs. Data will be automatically tagged as bad on all displays or logs if the input value is out of range. System accuracy shall be 0.1-percent of calibrated range, (excluding transmitters).

Analog output signals from the system will be isolated and either current limited or fused from the internal circuitry so that shorting, grounding or opening the circuit at the receiving Equipment will not affect control system performance. Analog outputs will not exceed eight per card. System accuracy will be less than 0.5-percent of output signal range (excluding final element).

Digital (contact) outputs will be individually fused in the control system. Digital outputs will not exceed 16 per card. Interposing relays will be used for all applications where the current and/or voltage requirements exceed the capability of the DCS outputs. The system will be capable of assigning each digital output as momentary or maintained. Momentary outputs will be present for at least 100 milliseconds but not more than two seconds. The system will be capable of providing normally open and normally closed contact outputs.

Digital (contact) inputs will be individually current limited. Digital inputs will not exceed 16 per card. Contact inputs will be scanned at the controller level for status change. Normal state for a contact will be definable as either open or closed. In general, digital inputs shall be failsafe or closed for normal state. The system software will have the ability to apply digital filtering or time delay to all contact inputs.

The DCS shall be capable of resolving at least 100 inputs for Sequence of Events (SOE) monitoring at a resolution of 1 millisecond. Control shall provide a preliminary SOE list for Owner review and approval. System shall be able to assign any digital point in the control system for SOE service. Grouping of these points is acceptable, but the points or groups may be distributed in all I/O locations including remote I/O. The provided GPS time stamping synchronization system shall be used for the synchronization of all system clocks and for the SOE time stamp.

The processing for thermocouple and RTD inputs is the same as that described for analog inputs above. The system will also check for open thermocouple and provide alarm. Thermocouple readings will be linearized.

#### **9.4 INTERFACES AND NETWORKS**

The DCS shall be interfaced to a number of systems throughout the plant and remotely to include, but not limited to the following:

1. GTG
2. STG
3. HRSG Duct Burner PLC's
4. RTU for Dispatch Control
5. CEMS
6. Plant Skids/systems implementing PLC's

The DCS control system components shall incorporate a 100mbps Ethernet communications network. The network shall be provided for control and monitoring from the operator, engineering servers and client workstations.

Data communication link interfaces shall be provided with watchdog timers and communications alarms.

All communications cabling running exterior to plant buildings shall utilize multimode fiber optic cabling with fiber patch panels, fiber to Ethernet media converters as specified in Section 8.0.

#### **9.5 REMOTE TERMINAL UNIT (RTU) DISPATCH**

An RTU to implement Dispatch Automatic Generation Control (AGC) will be furnished and installed in the switchyard control building by others. The Contractor will provide a fiber optic connection from the switchyard RTU located in the switchyard control building to the plant DCS. Provide all facilities required for RTU communications between the power plant and Switchyard control building. Any I/O points required at RTU but not available in the DCS shall be hardwired to the RTU. Facilities shall include but not be limited to, ductbank, fiber, wiring, programming, and interface equipment. The Contractor shall provide all required Fiber Patch Panels at the substation and control room and/or other location to allow for the complete termination of all fibers into and out of each location. The Contractor shall work with the Owner Dispatch Center and personnel and to test and commission the DCS to Dispatch link for control, monitoring and alarming functions as specified in Section 8.



## **9.6 DCS FACTORY ACCEPTANCE TEST (FAT)**

The Contractor and DCS manufacturer shall completely configure, load, and debug the DCS control system components and database at the factory or Contractor's facilities prior to FAT. A hardcopy printout and electronic copy of the I/O database, graphic screens, logic diagrams and detailed hardware configuration and FAT plan itemizing FAT activities shall be supplied to the Owner in advance for review and comment prior to finalization of system configuration and FAT. FAT plan and schedule shall be agreed to by Contractor and Owner early in the Project cycle. The DCS manufacturer shall provide 3 weeks for the FAT of the hardware, logic and software design and data communication interfaces. The FAT Logic shall be verified by simulation. Data communication links to the GTG, STG, and HRSG Duct Burner PLC shall be verified using a test simulator per the manufacturer's recommended practices. Owner shall witness FAT. DCS manufacturer shall provide problem or variance report sheets to document any and all problems encountered with hardware, software, graphic screens or control logic implementation. All problems found during the FAT shall be reconciled prior to shipment to the field. Owner reserves the right to require additional FAT, at Contractor's and/or DCS manufacturer's expense, if original testing proves the system design to be incomplete or substantial revisions are required.

## **9.7 HARD PANEL CONTROL BOARD**

Hardwired, redundant, emergency trip, mushroom-style push buttons one pair for each GTG, STG, and HRSG MFT one for the entire block, and one for closing the emergency fuel gas shutoff for Block 2 shall be provided as a part of the emergency shutdown protection panel.

## **9.8 INSTRUMENTATION AND CONTROL DEVICES**

### **9.8.1 General**

Signals for analog control system inputs and outputs shall be provided from process transmitters at 4-20 mA signal level, or direct-wired RTDs and thermocouples. Pneumatic signals shall be 3-15 psi.

Instrument primary sensing devices shall be nominally ranged at 150 percent of the systems normal operating pressures and temperatures.

Instrument calibration shall be verified by Contractor and documented for submittal to Owner.

Instrumentation and sensing lines shall be freeze protected where appropriate for instrumentation supplied by Contractor and by equipment manufacturer as required.

Gauges and indicators, including position indicators on valves, shall be installed to be visible from normal operating platforms or accessways without the need for ladders, mirrors, or other devices. All termination lugs shall be applied with a ratchet type crimping tool to insure an equal pressure connection between lug and signal cable core.

### **9.8.2 Thermocouples and Resistance Temperature Detectors**

Temperature measurement shall in most cases be performed using thermocouples. Thermocouples and extension wire shall comply with the standard limits of error according to ANSI MC96.1-1975 and shall be Type E.

Resistance temperature detectors (RTDs) of the three-wire platinum type shall be used in certain cases such as motor winding temperature measurements. The nominal resistance of the platinum detectors shall be 100 ohms at 0°C. All resistance temperature detectors shall be metal sheathed, and ceramic packed.

Thermocouples and RTDs shall have stainless steel sheathed elements and spring-loaded to provide good thermal contact with the thermowell. All connection heads shall be weatherproof equivalent to NEMA 4, with chain-connected screwed covers, and supported from the well by lagging extension long enough to clear the head of the temperature element above the process pipe lagging.

### **9.8.3 Thermowells**

Temperature sensors shall be equipped with thermowells made of one piece, solid bored Type 316 stainless steel (or higher alloy if required for the application) of step-less tapered design. Maximum bore internal diameter shall be 0.385 inch.

Test wells shall be provided on main steam, feedwater, condensate, and other piping as required to meet ASME test requirements. Test wells shall be provided with screw cap and chain.

### **9.8.4 Flow Elements**

Flow elements shall be provided in accordance with appropriate applications and in accordance with requirements contained in Section 5. Weld-in type Factory Certified Flow Nozzles shall be used for Main Steam, Hot Reheat and Cold Reheat flow measurements. Flow Nozzle shall be provided with two (2) sets of pipe wall pressure taps. All FEs required for performance testing shall be PTC6 certified to include but not limited to: HP and IP Feedwater, LP Steam, Condensate, and Cold Reheat.

### **9.8.5 Transmitters**

Transmitters shall be used to provide the required 4-20 mA DC signals to the DCS. Transmitters shall be of the smart electronic two-wire type, HART compatible and capable of driving a load of at least 500 ohms with non-interacting zero and span adjustments and remote recalibration features.

#### **9.8.5.1 Static Pressure and Differential Pressure Transmitters**

Differential pressure transmitters shall be HART compatible with transmitter sensor specified to withstand 150 percent of design pressure. DP transmitters shall be provided with remote seals and filled capillaries where required, static pressure protection limit and any other applicable options required to accommodate specific applications.

#### 9.8.5.2 Level Transmitters

Sensing elements for level transmitters shall be as follows:

1. Gauge pressure transmitters for vessels exposed to atmospheric pressure.
2. Enclosed, pressurized vessel level shall be measured using radar, ultrasonic, guided wave radar or Differential Pressure transmitters with filled capillaries and remote seals.
3. Differential Pressure element with constant head chamber for high pressure and temperature applications where installation of float cage becomes impractical (level transmitters of this type are the same as differential pressure transmitters).

#### 9.8.5.3 Flow Transmitters

Flow transmitters, in general, shall be differential pressure types. Square root extraction shall generally be performed electronically in the control system.

### **9.8.6 Gas Meters**

Meters used for fuel gas flow measurement shall be complete with temperature and pressure compensation capability using design pressure and temperature as its base conditions. Total gas flow shall be indicated locally, and gas flow rate shall be transmitted to, and monitored and totalized in, the DCS. Flow meters shall meet the requirement of the EPA and Currant Creek Air Quality Permit. Manufacturer's calibration certificate shall be provided that shows that flow meter meets the accuracy requirements of the EPA and Currant Creek Air Quality Permit.

### **9.8.7 Temperature, Pressure, Level, and Flow Switches**

Temperature, pressure level, and flow switches shall generally have two Form C contacts for each actuation point and shall be equipped with screw type terminal connections on a terminal block for field wiring. Switch set point and deadband shall be adjustable with a calibrated scale. Contacts shall be snap acting type. Switch enclosures shall be NEMA 4 for non-hazardous locations, and NEMA 7 or 9 for hazardous locations. All termination lugs shall be applied with a ratchet type crimping tool to insure an equal pressure connection between lug and signal cable core.

### **9.8.8 Local Indicators**

#### 9.8.8.1 Thermometers

Thermometers shall be the bimetallic adjustable, every-angle types with minimum 4-½ inch dials. Where view is obstructed or unavailable, thermometers shall be provided for remote mounting including filled capillaries..

#### 9.8.8.2 Pressure Gauges

Pressure gauges shall be the bourdon tube type with solid front cases with blowout back, 4-½ inch dials, stainless steel movements and nylon bearings. Gauges shall have ½-inch NPT bottom connections. Gauges shall be provided with pigtail siphons for steam service, snubbers for pulsating flow, and diaphragm

seals for corrosive or severe service. Gauges located on process lines exposed to ambient temperature shall be freeze protected.

#### 9.8.8.3 Local Level Indicators (Gauge Glasses)

Tubular gauge glasses shall be used for high-pressure applications. Mica shields shall be used with transparent gauges on steam/condensate service. All gauge glasses shall be equipped with gauge valves, including a safety ball check.

### **9.8.9 Control Valves**

Control valves shall be used in modulating service throughout various processes within the facility and as specified in Section 5. Globe valves shall be used extensively in water, steam, gas, and oil service with butterfly and ball valves used in limited applications, typically low pressure and temperature water service.

Pressure retaining component and valve trim materials shall be selected based on process conditions such as type of fluid, static and differential pressures, and temperature. In general, control valves in water and steam service shall be provided with hardened stainless steel trim.

Modulating control valves shall be sized to pass design flow at 60 to 80% of valve capacity. Multiple service conditions should be specified when a control valve is expected to operate over a wide range of travel, i.e., feedwater flow and drum level control valves. When the calculated Cv is less than the manufacturer's recommended minimum Cv, two valves with split range control shall be provided, unless otherwise approved by Owner.

Minimum control valve body size shall be not less than 50% of the upstream pipe size. When a calculated Cv requires a smaller valve, reduced trim shall be used in order to maintain the body size requirement. Reduced trim shall not be less than 40% of valve capacity.

Pneumatic actuators of the diaphragm or piston/cylinder type shall be Smart, Hart compatible, with the ability to provide position feedback and diagnostic information on each valve. All critical valves shall be equipped with hardwired position feedback modules. Careful consideration should be given to the fail-safe position of control valves. Where practicable, actuators with integral springs shall be specified. All control valves shall be capable of operating with a 60 psig air header pressure.

In general, all control valves shall have ANSI class IV leakage ratings. Valve failure philosophy shall be developed with Owner participation.

Control valves shall be designed to operate from a control signal range of 3 to 15 psi.

Each control valve shall be provided with accessories such as handwheels, filter regulators, solenoid pilot valves, limit switches, and position indicators as applicable.

### **9.8.10 Instrument Racks**

Where possible, field instruments other than local indicators shall be grouped together on instrument racks. Maximum tubing run from the sensing point to the rack shall be 50 feet, unless approved otherwise by Owner. Interior instrument racks shall be open structures with frames constructed of angle or structural tubing. The frames shall be reinforced as required to provide adequate support for instruments and equipment. Equipment supports shall be horizontal members, which provide a place for the attachment of mounting brackets and clamps for piping and tubing.

Instruments exposed to ambient temperatures shall be housed in heated instrument enclosures with heat traced impulse lines with integral tubing bundle. Integral tubing bundle shall be O'Brein or Owner approved equal. Heated enclosures shall be diagonal, clam-shell style to provide easy access to process instruments from the front, top or either side. No flexible insulation (soft-case) is acceptable. Enclosures shall have a maximum of three (3) instruments each and shall be large enough to house all required blowdown valves inside enclosure. Heat trace system shall be designed to activate enclosure heaters when ambient temperature is below 40 degrees Fahrenheit. Heat trace panel requirements are defined in Section 8.

### **9.8.11 Tubing Systems**

Instrument, control, and sampling tubing systems shall be designed, fabricated, and tested in accordance with ANSI ISA RP 7.1.

Primary process instrument and sampling tubing for steam and water systems shall be ASME SA213 grade TP316H SS 3/8 inch .049 standard wall or 1/2 inch .065 standard wall, respectively (Note: On high pressure, high temperature applications, tubing shall be 316H minimum wall per ANSI B31.1 specifications).

Fittings shall be manufactured of the same material as the tubing, wherever practical. Where not practical, fittings shall be manufactured of a harder material than the tubing and at minimum of Rockwell 80B.

Pressure type instruments shall have associated isolation and test valves or combination two-valve isolation/test manifolds. Differential pressure type instruments shall have associated pairs of isolation and test valves plus an equalizing valve or combination three-valve isolation/test/equalizing manifolds.

Blowdown valves shall be provided for each remote device as required. Tandem blowdown valves shall be provided on high pressure, high temperature applications (pressure greater than 600 PSIG and/or temperature greater than 450 degrees Fahrenheit). Blowdown valves are not required for vacuum, gas, or dry air service.

Sample tubing systems carrying high temperature samples shall be insulated or guarded in areas which require personnel protection.

## **9.9 CONTROL SYSTEM LOOP COMPONENT DESIGN**

The major plant systems to be controlled and monitored are as described and presented in Section 5. They include the following:

1. Gas Turbine/Generator Systems.
2. Steam Turbine/Generator Systems.
3. Heat Recovery Steam Generator Systems.
4. Feedwater Systems.
5. Circulating Water System
6. Water Treatment System
7. Wastewater Treatment System (if required)
8. Fuel Gas Metering and Conditioning System.
9. Plant systems, Raw Water controls tie to Block 1
10. Plant Monitoring System.

#### **9.9.1 Gas Turbine Generator (GTG)**

The GTG and GTG control system requirements are described in Section 5 of these Specifications. The DCS shall be implemented to provide supervisory control, monitoring, alarming and historical functions for each GTG and shall interface to GTG systems through hardwired and data link interfaces. The DCS shall be able to perform all actions necessary to start and stop the unit, raise and lower load, monitor status, log operating data, and annunciate and acknowledge alarms. Critical control functions, status and alarms for essential gas turbine operation will be hardwired to the DCS control system. Remaining control functions, status, and alarms shall be interfaced through a high speed 100 Mbps, fiber data link per manufacturer's recommended configuration. The link will provide all data on the manufacturer's standard interface list, as required. Final determination of I/O will be subject to Owner approval. Key GTG system control, alarm, and status graphics shall be integrated with the DCS to provide the identified supervisory control. A common GTG Remote HMI shall be provided in the main control room for detailed controlling, alarming, and monitoring of the Gas Turbine system. The main control room shall serve as the primary operator interface. Gas turbine controls shall be designed to minimize unnecessary trips, nuisance alarms, and false starts. Runbacks, rather than trips, shall be utilized whenever possible.

All critical control trips and interlocks shall be hardwired between the DCS and the GTG control system. Remote manual tripping of the GTG shall be possible using the auxiliary console-mounted, hard-wired emergency stop pushbuttons located in the control room.

The Contractor shall submit with Bid a conceptual Control System Architecture diagram outlining the anticipated configuration for Owner review. This diagram shall define what control and monitoring functions will be provided at the centralized control room, and at various locations throughout the system, location of each I/O drop, number of processors at each location, approximate number and type of I/O at each location, PLC drops, communications protocol, and other applicable information.

### **9.9.2 Steam Turbine Generator**

The steam turbine generator will be provided with a dedicated microprocessor based control system that includes an electronic governor for speed and load control with all standard interlocks required for start-up, loading, shutdown, and tripping of the turbine-generator. The steam turbine speed control and inlet pressure control will be done through the governor. Comprehensive supervisory systems and equipment for monitoring operational status, alarms and automatic protection shall be provided for the safe, reliable remote operation of the machine. The STG and STG control system is described in Section 5 of these Specifications.

The DCS shall provide supervisory control, monitoring and alarming for the STG and shall interface to the STG control system and governor through hardwired and data link interfaces. The DCS interfaces to the STG control system shall be in accordance with the turbine manufacturer's recommended configuration. The DCS, through a combination of hardwired and data link interfaces, shall be able to perform all actions necessary to start and stop the unit, raise and lower load, monitor status, log operating data, and annunciate and acknowledge alarms. Critical control functions, status and alarms for essential steam turbine operation will be hardwired to the DCS control system. Remaining control functions, status, and alarms shall be interfaced with each STG control systems through a high speed 100 Mbps fiber data link per manufacturer's recommended configuration. The link will provide all data on the manufacturer's standard interface list, as required. Final determination of I/O will be subject to Owner approval. Key STG system control, alarm, and status graphics shall be integrated with the DCS to provide the identified supervisory control. A STG Remote HMI shall be provided in the main control room for detailed controlling, alarming, and monitoring of the steam turbine system. The main control room shall serve as the primary operator interface.

All critical control trips and interlocks shall be hardwired between the DCS and the STG control system. Remote manual tripping of the STG shall be possible using the auxiliary console-mounted, hard-wired pushbuttons located in the control room

### **9.9.3 Heat Recovery Steam Generator (HRSG)**

Control of the HRSG shall consist of the following loops under control of the DCS to safely and efficiently maintain steam header pressure and feedwater to match turbine-generator requirements during start-up, normal operation, upsets, and shutdown. Duplicate controls shall be supplied for each HRSG, as required. Consult Section 5 for further requirements.

Control of each HRSG shall include the following subsystems:

1. Drum Level Control Systems.
2. Duct Burner Safety System.
3. Ammonia Injection Control System
4. Steam Temperature Controls.

#### 9.9.3.1 Drum Level Control System

The HRSG drum level control system shall be conventional three-element control using main steam flow as the feed-forward signal, drum level, and feedwater flow as the feedback signals. Based on demand, the system controls the feedwater control valve to adjust feedwater flow to the HRSG. The system will be designed to operate on single-element control using drum level only during start-up. Transfer from single-element to three-element and back to single-element shall be automatic based on steam flow.

#### 9.9.3.2 Duct Burner Safety System

The duct burner control system shall be fully integrated with the plant DCS. The duct burner safety system shall be a self-contained PLC and shall be designed to safely shut down the HRSG auxiliary burner system on abnormal and emergency conditions. The system shall be interlocked to shut down the fuel gas to the HRSG as recommended by the HRSG manufacturer. The duct burner safety system shall comply with NFPA 8506 and the NEC code. The duct burner safety system shall incorporate hardwired and softlink status, alarms, controls signal for control and monitor from the DCS.

#### 9.9.3.3 Ammonia Injection Control System

The ammonia injection control system shall be designed to control stack emissions to meet permit requirements.

#### 9.9.3.4 Steam Temperature Control System

The purpose of this system is to maintain the final superheater and reheater outlet temperatures at a set value with minimum fluctuation. This shall be a single station, cascade-type control system in which the final superheater and reheater outlet control units serve as the master or primary control units, and the desuperheater outlet control units serve as the slave or secondary control units.

### **9.9.4 Feedwater System**

Feedwater systems will be comprised of the following subsystems:

1. Wet Surface Condenser Hotwell Level Control.
2. Boiler Feed Pump Minimum Flow.
3. Boiler Feed Pump Vibration Monitoring

#### 9.9.4.1 Wet Surface Condenser Hotwell Level Control

The hotwell level shall be controlled from the DCS. Cycle water make-up flow shall be regulated through a control valve to maintain condenser hotwell level. If the level is low, make-up will be admitted from the demineralized water storage tank. If the level is high, a fraction of the condensate flow will be routed to the demineralized water storage tank to prevent condenser flooding. Level switches shall be provided to alarm high and low levels. Pump run indicators shall be provided to alarm pump cutout. Hotwell shall also be provided with local level indication.



#### 9.9.4.2 Boiler Feed Pump Minimum Flow Control

Feedwater pump minimum flow control consisting of a recirculation valve which circulates water back to the LP drum during periods of low HRSG feedwater demand shall be provided. This may be in the form of a flow control valve.

#### 9.9.4.3 Boiler Feed Pump Existing Vibration Monitoring

BFP shall be equipped with Bentley Nevada Vibration Monitoring Control monitoring systems. This system shall be tie to Block 1 main Bentley Nevada Vibration Monitoring System.

### **9.9.5 Circulating Water System**

The system comprises the following subsystems:

#### 9.9.5.1 Cooling Tower Make-Up Control System

The DCS control systems shall sense the level in the cooling tower basin and adjust the make-up water control valves accordingly. Abnormal basin levels shall be monitored by independent level switches for alarm and/or trip functions.

#### 9.9.5.2 Cooling Tower Fan Control

The cooling tower fans shall be controlled automatically from the DCS as required to maintain a manually, operator selected makeup rate to the cooling tower.

#### 9.9.5.3 Circulating Water Pumps Control

The circulating water pumps control shall be controlled from the central control room. Circulating pump discharge valves shall be controlled by each respective DCS and automatically open as part of the respective pump start sequence and close on pump shutdown.

### **9.9.6 Water Treatment Systems**

The water treatment systems shall be prepackaged units with self-contained PLC controls. All data from the water sample panels shall be provided for control, monitoring and alarming in the DCS.

### **9.9.7 Fuel Gas Metering and Conditioning System**

The Fuel Gas Metering and conditioning system shall be prepackaged units with self-contained PLC controls. Data from this system shall be provided via communication link and/or hardwired interface for monitoring and alarming in the DCS. See Section 5 for system requirements.

### **9.9.8 Plant Systems – Raw Water**

Block 1 Raw Water Supply System shall be modified to support the new Block 2 combine cycle plant. Block 1 Raw Water System includes two (2) existing Well pumps, and an existing Raw Water Storage Tank. A second Raw Water Storage Tank shall be added for Block 2. Modification of existing Block 1 Raw water system and controls may

be required to enable Block 2 to control existing well water pumps, and to monitor the level in Block 1 Raw Water Tank.

### 9.9.9 Plant Monitoring System

Plant parameters shall be monitored and indicated, alarmed and/or recorded in the DCS to facilitate the plant operator with control of the plant. The gas turbine and steam turbines shall be interfaced to the DCS for monitoring, trending, and control from the DCS. All local controllers shall be interfaced with the DCS for monitoring, trending, and control from the DCS.

### 9.10 HISTORICAL DATA STORAGE AND RETRIEVAL

Provide historical trending of all DCS data points including data provided from the combustion turbine and steam turbine control systems. Provide enough on-line memory to support a 34-day recall of all data points taken at the following periods:

Temperature:	5 min.
Levels:	1 min.
Pressures:	1 min.
Flows:	15 sec.

Provide a CD/DVD writer in the control system to facilitate downloading and archiving of the trended data.

### 9.11 CONTINUOUS EMISSIONS MONITORING SYSTEMS

Dedicated extractive continuous emissions monitoring systems (CEMS) complete in all respects including analyzers, sample extraction system, sample lines, flue gas flow equipment, data acquisition system, controllers, printer, monitor display, keyboard, mouse, software, controls, modem link, and other system specific accessories shall be installed the bypass stack and HRSG stack to measure the NO<sub>x</sub>, CO, and O<sub>2</sub> concentrations at the HRSG stacks. A switching mechanism based on bypass damper position will direct the stack gas to the CEMS. The CEMS shall be housed in a shelter located at the base of the HRSG stacks.

Additional NO<sub>x</sub> monitors shall be installed in HRSG upstream of SCR catalyst to monitor ammonia injection and CTG emission rates.

Each CEMS shall meet all the requirements of the plant air quality permit and state and local regulations. The CEMS shall be designed to comply to the requirements of the Environmental Protection Agency as stated in 40 CFR Part 60 "Standards of Performance for New Stationary Sources," specifically Paragraph 40 CFR 60 Subpart GG; 40 CFR Part 60.13; 40 CFR 50 Appendices B and F; and 40 CFR Part 75.

Each CEMS shall monitor the operation of each unit by obtaining a reading of NO<sub>x</sub>, CO, and O<sub>2</sub> concentrations at least once every 15 minutes for each unit for each sample point, and shall display the following air pollution control parameters:

1. Exhaust unit flow.

2. NO<sub>x</sub>, CO, and O<sub>2</sub> in ppmv at actual stack conditions.
3. NO<sub>x</sub> in ppmv and lb/hr upstream of SCR catalyst.
4. NO<sub>x</sub>, CO, and O<sub>2</sub> in ppmv corrected to 15% oxygen on a dry basis.
5. NO<sub>x</sub> and CO in lb/hr.
6. Temperature at the SCR.
7. NO<sub>x</sub> at SCR inlet.
8. Fuel consumption.

Each CEMS shall be designed with a stand-alone personal computer, with an emissions software package which includes emissions warning, archiving, and report generation, as required under CFR 40, Part 60, Appendix F; 40 CFR PART 75; and the air quality permit. Daily calibration error test can not exceed 5.0% of span value (or exceed 10 ppm). Linearity – No quarterly linearity test required. RATA shall be  $\leq$  0.015 lb/MMBtu mean difference.

The CEMS personal computers shall be networked together with a supervisory station located in the control room. The DCS shall interface with the CEMS supervisory station through a communication link. The link shall provide up to 50 analog data points and 75 digital data points.

The dedicated extractive CEMS shall be supplied with the following analyzers and systems:

1. NO<sub>x</sub> Analyzer shall be TE 42i-LS Dual Range ( Low 0 – 5 ppm, High 0 – 200 ppm) Note: Readings obtained during typical unit operation shall be kept between 20.0 and 80.0 percent of full-scale range of the instrument (1 – 4 ppm).
2. CO Analyzer shall be TE 48i CO Dual Range (Low 0 – 10 ppm, High 0 – 150 ppm).
3. Oxygen Analyzer shall be Servomex 1440 with Range: 0 – 25%.
4. Extractive Sample Probe shall be M&C SP-2020 EXTRACTIVE or Universal 270S w/ heated stack filter.
5. Sample Line will be heat traced with a temperature controller capable of maintaining 240 degrees F at minus 20 degrees F ambient. Each sample line will consist of three (3) 3/8" Teflon tubes ( sample line, blow back, spare) and two (2) 1/4" Teflon Tubes (calibration gas, spare).
6. Sample Conditioner shall be M&C or Universal and shall utilize the peltier effect for condensing moisture from the gas sample. The condensate will be removed with a Masterflex dual head peristaltic pump. The sample system must include an inline 2.0 micron particulate filter and a moisture conductivity sensor.

7. Contractor provided Fuel Flow meter shall be\_Yokogawa vortex flowmeter. The flowmeter must be certified for Part 75 using the applicable procedure found in 40 CFR Part 75, Appendix D, section 2.1.5. The certification results must accompany the flowmeter.

#### **9.12 ONLINE PERFORMANCE MONITORING SYSTEM**

Contractor shall supply a General Physics Eta-Pro Performance Monitoring System including software license and all equipment and services required for software configuration, installation, testing, and training to provide a fully functional performance monitoring system. The system will provide plant and component performance at actual operating conditions compared to expected plant and component performance at the operating conditions. Expected plant and component performance shall be adjusted to levels demonstrated in the plant performance tests.

The system shall include the following:

1. Gas Turbine Performance. Actual and expected performance of each GTG based upon OEM correction curves for heat rate, heat consumption, exhaust energy, exhaust temperature, compressor pressure ratio and efficiency. Performance shall be calculated based upon ambient conditions and selected load. Effects of evaporative inlet cooling shall be included in the calculations.
2. HRSG Performance. Actual and expected performance of each section of the HRSG to include duct burner duty, efficiency, pinch points, steam flows and temperatures.
3. Steam Turbine Performance. Actual and expected steam turbine performance of the HP, IP, and LP section at actual steam and backpressure conditions.
4. Condenser Performance. Actual and expected condenser performance at actual steam and circulating water conditions including terminal temperature difference, log mean temperature difference, subcooling, duty, heat transfer coefficient and cleanliness factor and STG backpressure.
5. Cooling Tower Performance. Actual and expected cooling tower performance at actual ambient temperature and wind conditions and load conditions including approach, duty, and STG backpressure.
6. Pump Performance for Circulating Water Pumps, CCW Pumps, Boiler Feed Pumps, and Condensate Pumps. Actual and expected pump performance at actual operating conditions including efficiency, head and power consumption. Boiler feed pump calculations shall include consideration of variable speed drive.
7. Contractor shall provide software customization including screens, reports, and performance calculations as reviewed and approved by Owner. Reports shall be in Excel spreadsheet format.

Contractor shall provide a plant weather station to provide necessary ambient inputs such as wet bulb temperature, relative humidity, barometric pressure, and wind speed and direction.

The system shall interface with Owner provided PI Historian. Contractor shall provide all interfaces required for the PI system as necessary for a complete and operable system.

The system shall be designed to allow expansion to an Owner supplied LAN serving other PCs at a later date.

## **SECTION 10.0**

### **TRAINING PROGRAM**

The purpose of the training program is to provide specific information about the power plant to qualified operator trainees. The overall intent is to provide a comprehensive program that will increase the competence level of the plant operating personnel to ensure that the plant can be safely operated.

The training shall consist of basic theory, as well as specific technical training on major equipment and systems functions. The basic theory shall provide an effective base for those who have had no formal training, and a refresher for those who have experience. This shall prepare everyone to a common level for specific technical training on major equipment and systems.

The training program shall include, at a minimum:

1. Classroom instruction with active instructor-trainee interaction and utilize a full range of training materials and professionally produced training tapes.
2. In-plant, hands-on training by various instructors and major equipment suppliers.
3. Exercises to familiarize trainees with all the different systems in the plant.

Skill testing and progress monitoring shall be used throughout the training program to gauge the effectiveness of the training and the knowledge of the trainees. All training shall be reviewed with Owner on an ongoing basis.

Training program shall be in accordance with the Section 4.16 (provide 30 copies of the training manuals) of the Contract and shall include a minimum of 40 hours of overall plant training by Contractor. Training program shall also include major equipment training to be conducted by the equipment vendors. Vendor training for equipment purchased by Owner shall be coordinated and managed by Contractor. As a minimum Vendor training shall be provided for the following equipment (Owner has the right to review duration and curriculum of each training session to determine if additional training is required):

1. Combustion turbine generators
2. Steam turbine generator
3. Transformers
4. Heat recovery steam generators including duct burners and SCR ammonia injection systems.
5. Boiler feedwater pumps
6. Gas Compressors

7. Distributed control system
8. Continuous emissions monitoring system
9. Permanent On-Site Water treatment system
10. Wet surface Condenser and Cooling Tower

## SECTION 11.0

### START-UP, INITIAL OPERATION AND PERFORMANCE TESTING

#### 11.1 GENERAL

##### 11.1.1 SUMMARY:

1. Contractor to prepare all Equipment and systems installed under this Agreement for initial operation in accordance with the manufacturer's instructions, these Specifications, and as indicated on the Reference Drawings.
2. Contractor to provide all labor and materials to perform cleaning, flushing, sterilization, steam line blowdown, operational checks and adjustments, and preparation for initial operation.
3. Contractor shall cooperate with BuyerOwner and manufacturer's service personnel during the start-up period.
4. Contractor to provide all supervision and labor as required for initial operation of all piping systems, equipment and appurtenances installed under this Agreement until they are accepted for initial operation
5. Owner shall provide to the Contractor all reasonable and necessary support during the commissioning and startup of the Plant.
6. Owner shall provides operations and maintenance staff personnel to participate in the commissioning activities. This support shall be provided during normal working hours or other times as may be requested by the Contractor with advance notice.
7. General Requirements:  
Perform specified inspections and tests and report all deficiencies in Equipment and Materials to Owner immediately upon becoming aware of them. Where applicable, perform Work under the direction of equipment manufacturer's field service representatives.
  - A. Contractor shall be responsible for any damage to Equipment or Material due to improper test procedures or test apparatus handling, and replace or restore to original condition at the Owner's option, any damaged Equipment or Material.
  - B. Contractor shall furnish miscellaneous hand tools, ladders, or scaffolding, as required, to allow access to equipment, boxes, cabinets, or devices.
  - C. Certain inspections and tests specified to be performed by this Agreement may also be performed by others. This overlapping and duplication is necessary and intentional. Contractor will be notified of tests by others prior to test to assure proper safety procedures are followed.
  - D. Owner will review and approve the testing schedule of all plant testing and inspections. Contractor shall cooperate and work closely with Owner during all phases of construction, especially with respect to the following:
    - 1) Sequence and priorities of construction and start-up.
    - 2) Testing and testing methods.
    - 3) Equipment checkout and procedures.
    - 4) Equipment start-up.
    - 5) Testing records.
    - 6) Tagging procedures for personnel and equipment safety.



#### **11.1.2 QUALITY ASSURANCE:**

1. Perform all work to meet the quality specified hereinafter and the quality assurance requirements of the Equipment manufacturers, including, but not limited to, the following standards:
2. American National Standards Institute (ANSI).
3. American Society of Mechanical Engineers (ASME).

#### **11.1.3 SUBMITTALS:**

1. Submit as specified in Section 4 of this Specification. Submittals required shall include the following:
  - A. Contractor shall submit a detailed flushing and cleaning procedure 90 days prior to performance of the activity. This will include, but not be limited to, calculations, demineralized water source, disposal procedure, pipe routings, auxiliary requirements, equipment source, schedules, etc.
  - B. Contractor shall submit a detailed steam blow procedure 90 days prior to performance of the activity. This shall include, but not be limited to, calculations, pipe routings, steam requirements, support designs, schedules, etc.
  - C. Contractor shall submit a detailed gas blow procedure 90 days prior to performance of the activity. This shall include, but not be limited to, calculations, pipe routings, support designs, schedules, etc.

#### **11.1.4 ACCEPTANCE AND PERFORMANCE TESTS:**

1. After a period of initial operation, a performance test will be conducted on the complete power plant.
2. If operation and performance of the power plant is unsatisfactory due to any deficiency in Contractor's Work, Contractor shall make repairs and redo his Work to obtain satisfactory operation and performance.

#### **11.1.5 EXECUTION**

1. FLUSHING AND CLEANING:
  - A. General:
    - 1) Flush, hydro-blast, or blow out all piping systems and Equipment to remove all dirt, scale, chips, and other foreign material.
    - 2) Furnish and install all necessary equipment and materials required for flushing and cleaning including pumps, temporary blank-off plates, steam sources and supply lines, special fittings, temporary piping systems, gaskets, supports, anchors, and bracing required for the flushing and cleaning operations.
    - 3) Provide temporary water supplies for filling and flushing and provide temporary drain lines and hoses for disposal of water without flooding.
    - 4) Furnish labor and materials to dismantle Equipment and open handholes and manholes as required to inspect and clean piping and Equipment.
    - 5) Furnish labor, materials, portable pumps, and equipment to clean out and inspect existing sumps and tanks.
    - 6) Remove orifice plates and flow element from pipelines before cleaning and flushing and reinstall after cleaning and flushing.
    - 7) Remove control valve internals before cleaning and flushing and reinstall after cleaning and flushing.

Rev. 0

- 8) Remove, clean and replace pump suction strainers as necessary during cleaning and flushing operations.
  - 9) Protect all equipment during cleaning and flushing.
  - 10) Protect instruments and appurtenances during cleaning and flushing.
  - 11) Remove all temporary piping, supports, anchors, bracing, fittings, and blank-off plates after flushing.
  - 12) Reassemble all Equipment ready for operation. Furnish and install new gaskets as required to reassemble Equipment.
- B. Heat Recovery Steam Generator (HRSG) cleaning:
- 1) Perform a hot alkaline detergent degreasing and cleaning of the HRSG in accordance with OEM recommended cleaning procedures. Alternative cleaning measures may be proposed by the Contractor for Owner consideration, acceptance of which is in Owner's sole discretion.
  - 2) Cleaning shall be performed by a firm specializing in such services.
  - 3) Provide all required chemicals and equipment including heat source necessary to heat cleaning solution to proper temperature. Provide all piping, hoses, and drain lines required to deliver water and chemicals to the unit for cleaning. Dispose of waste offsite after cleaning is completed.
  - 4) Install orifice plates in HRSG downcomers to obtain 0.5 – 1.0 ft/sec flow rate during alkaline degrease cleaning.
  - 5) After boilout, open the unit, wash down, and inspect. Replace gaskets, gauge glasses, and other parts damaged by boilout with new parts and material.
- C. Condensate System:
- 1) Thoroughly clean the condensate system from the condenser to the Heat Recovery Steam Generator (HRSG) preheater inlet.
  - 2) Hydro-blast clean the condensate suction and discharge piping from the condenser hotwell to the HRSG preheater inlet connection as follows:
    - a. Install blanking plates on the following:
      - (1) Condenser hotwell outlet connections.
      - (2) Suction and discharge of the condensate pumps.
      - (3) Inlet and outlet of the Inter/After condenser and gland steam condenser.
    - b. Clean the main condensate header by hydro-blasting as specified.
    - c. Hydro-blast from the hotwell discharge connection to the condensate pump suction strainer (typical each pump).
    - d. Hydro-blast from the condensate pump suction expansion joint inlet (do not hydro-blast the expansion joint) to the suction strainer (typical each pump).
    - e. Hydro-blast from the condensate pump discharge cleaning connection to the pump discharge connection (typical each pump).
    - f. Hydro-blast from the condensate pump discharge to the HRSG preheater inlet connection.
    - g. When hydro-blasting is completed remove blanking plates from Inter/After condenser and gland steam condenser and flush the main header from the condensate pump discharge cleaning connection to the HRSG preheater inlet connection with condensate. Then flush each branch line in the condensate system with condensate. Flush until system is clean as determined by Owner.
- D. Feedwater System:
- 1) Thoroughly clean the boiler feed pump suction and discharge piping from the LP drum to the HP economizer inlet.
  - 2) Hydro-blast clean the suction and discharge piping as follows:
    - a. Install blanking plates on the inlet and outlet of the boiler feed pumps.

Rev. 0

- b. Hydro-blast clean the boiler feed pump suction line from the HRSG LP drum to the pump suction connection.
  - c. Hydro-blast clean the boiler feed pump HP discharge line from the boiler feed pump HP discharge to the HRSG HP economizer inlet.
  - d. Hydro-blast clean the boiler feed pump IP discharge line from the boiler feed pump IP discharge to the HRSG IP economizer inlet.
  - e. Hydro-blast clean the boiler feed pump recirculation line from the boiler feed pump HP discharge to the HRSG LP drum inlet.
  - f. Hydro-blast clean the feedwater line from the IP economizer outlet to the fuel gas heater inlet and from the fuel gas heater inlet to the condensate header. Add blanking plates on the fuel gas heater connections during hydro-blasting operations.
  - g. When hydro-blasting is complete flush each branch line in the feedwater system with condensate from the boiler feed discharge cleaning connection throughout the system. Flush until system is clean as determined by Owner.
- E. Steam Systems:
- 1) Thoroughly clean the following steam system main lines by hydro-blasting:
    - a. Main high pressure steam lines from the main steam turbine stop valves to the HRSGs superheater outlet.
    - b. Main high pressure steam bypasses to cold reheat line.
    - c. Main high pressure steam reverse flow discharge valve to condenser.
    - d. Hot reheat steam lines from the hot reheat stop valve to the HRSG reheater outlet.
    - e. Hot reheat steam line bypasses to the condenser.
    - f. Cold reheat steam lines from the steam turbine cold reheat check valve to the HRSG reheater inlet.
    - g. Low pressure steam lines from the LP inlet butterfly isolation valves at steam turbine or the HRSG LP superheater outlet.
    - h. Low pressure steam line bypasses to condenser.
    - i. Power augmentation steam lines from the HP steam line to the Combustion Turbine (GTG) power augmentation steam inlet.
    - j. All common steam lines as listed above.
  - 2) Install blanking plates where required.
  - 3) Perform steam blow cleaning as specified below.
- F. Hydro-blasting requirements:
- 1) Hydro-blasting equipment minimum requirements shall be as follows:
    - a. Shall be high pressure water nozzle cleaning designed to be self propeller and revolve.
    - b. Cleaning nozzle shall be supplied with a minimum pressure of 13,000 psig and a minimum flow of 50 gpm.
    - c. Nozzle rotation speed and feed rate shall be as required to blast clean 100 percent of the interior pipe surface.
    - d. Nozzle withdraw rate shall not exceed 3 feet per minute and be as required to flush clean pipe.
    - e. Feed and withdraw shall provide two pass cleaning/flushing.
  - 2) Remove items from Equipment and pipelines that might be damaged during hydro-blasting, including, but not limited to, flow elements, control valves, instruments, etc.
  - 3) Do not hydro-blast expansion joints.
  - 4) Blast in segments as required to achieve complete cleaning.

- 5) Hydro-blast in a manner that allows water to wash debris to be flushed from system high points in the system to low points.
  - 6) Direct hydro-blast discharge to plant floor drains. Install temporary pumps in the oil/water separator and discharge cleaning/flush water to plant drainage ditch in a manner which does not cause erosion.
- G. Water Flush Other Liquid Systems:
- 1) Flush all other systems until clean as determined by Owner.
  - 2) Remove items from, blank off or bypass Equipment and pipeline items that might be damaged during flushing, including, but not limited to, flow elements, control valves, instruments, etc
  - 3) Discharge flush water to plant drainage ditch in a manner which does not cause erosion.
  - 4) Permanent plant pumps may be used for flushing. Turn all system pumps on when flushing.
  - 5) Flush the main headers and each branch line.
  - 6) Flush the raw water system from the well pumps to the raw water storage tank.
    - a. Flush from each well.
    - b. Flush to include underground piping, above ground piping and branch lines.
    - c. Install temporary drainage pipe from tank inlet to existing drainage ditch.
  - 7) Flush the potable water system from the raw water supply to the potable water skid inlet and throughout the potable water system as it applies to the system extension.
    - a. Flush from the water treatment plant.
    - b. Flush to include underground piping, above ground piping and branch lines.
    - c. Install temporary drainage pipe from the potable water skid inlet to existing drainage ditch.
    - d. Flush from the potable system to each eye wash and shower and each fixture.
    - e. Flush the service water system as it applies to the system extension.
    - f. From the raw water tank to the service water pumps.
    - g. From the service water pumps to the RO/Demineralizer system, blowdown tanks, miscellaneous drains tank, and cooling tower.
    - h. From the service water pumps to hose bibs.
    - i. All other branch lines.
  - 8) Flush the demineralized water system as it applied to the system extension
    - a. Flush through all demineralized water system piping and evaporative cooler make-up system.
    - b. Install blanking plates on all equipment connections. Disconnect piping at equipment and direct flush water to existing drainage.
    - c. All other branch lines.
  - 9) Flush the boiler makeup water system.
    - a. From demineralized water tank to boiler make-up pumps.
    - b. From boiler make-up pumps to condenser, evaporative coolers, to deaerator, etc.
    - c. All other branch lines.
  - 10) Flush the closed cooling water system.
    - a. From the closed cooling water pump to each heat exchanger and the return line back to the pump.
    - b. Install a temporary bypass around the closed cooling water heat exchanger.
    - c. Install temporary bypasses around each heat exchanger.

Rev. 0

- d. All other branch lines.
- 11) Hand swab the circulating water and auxiliary cooling water piping clean.
- 12) Chemical feed, ammonia and sample lines. (These lines may be air blown at Contractor option.)
  - a. Flush with temporary pumps.
  - b. Disconnect piping at process connections and flush water to existing drainage.
- 13) Boiler blowdown and steam turbine drains.
  - Flush to respective blowdown and miscellaneous drains sumps.
- 14) General drains.
  - Flush with general drains pumps.
  - Flush to the collection sump.
- 15) Combustion Turbine drains.
  - Flush with temporary pumps to the wash water sumps.
  - Install temporary pumps in the wash water and discharge cleaning/flush water to plant evaporative pond in a manner which does not cause erosion.
- 16) Open up Equipment and clean and flush.
- 17) Provide all temporary pump, pipe, and Equipment as required
- H. Air blow the following systems:
  - 1) Contractor shall provide source of compressed air for air blowing purposes.
  - 2) Blow piping at a minimum velocity of 200 fps until air is free of grit and foreign material as determined by Owner.
  - 3) Air blow the following systems:
    - a. Instrument air
    - b. Compressed gas carbon dioxide
    - c. Compressed gas hydrogen
    - d. Compressed gas nitrogen
    - e. Compressed generator gas
    - f. Combustion turbine bleed heat lines
    - g. All 2 inch and smaller Combustion Turbine Generator system lines
    - h. All lube oil lines
- I. Equipment:
  - 1) Open all Equipment installed by this Agreement including, but not limited to, the following for inspection, swab, blow out, flush, and clean.
    - a. Condenser water box and hotwell.
    - b. Blowdown and miscellaneous drains tanks.
    - c. Auxiliary boiler deaerator.
    - d. Closed cooling water expansion tank.
    - e. Wastewater tanks.
    - f. Compressed air receivers.
    - g. Ammonia Storage Tank.
    - h. Circulating Water and Auxiliary Cooling Water Pipe.
    - i. Demineralized Water Tank.
    - j. Raw Water Storage Tank.
    - k. Oil/water separator.
    - l. Wash Water Tank.
    - m. Cooling Tower Basin.
  - 2) Thoroughly inspect, clean, and flush any other Equipment affected by the flushing operations.
  - 3) Furnish and install new manhole gaskets as required.

- J. Lubricating and Hydraulic Oil Systems:
    - 1) Thoroughly clean and flush steam turbine and boiler feed pump lubricating and hydraulic oil systems until clean and in accordance with manufacturer recommendations and instructions.
    - 2) Provide a separate flushing pump for the steam turbine lube oil flush.
    - 3) Heat oil, circulate oil, vibrate lines, clean strainers, and replace filters in accordance with Equipment manufacturer's instructions. Contractor shall furnish all flushing oils. Flushing oils shall meet the requirements of the equipment manufacturers.
    - 4) Contractor shall be responsible for all costs and equipment associated with flushing oil testing required to confirm if the oil system flushing operations has satisfied the manufacturer's requirements and recommendations.
    - 5) Drain systems, dispose flushing oil off site, wipe out reservoirs, and clean as required.
    - 6) After flushing dispose flushing oil offsite. Fill lubricating systems with oil and lubricate Equipment.
  - K. Initial Turbine Operation:
    - 1) After turbine stretch-out or when directed by Owner, dump the condenser hotwell to waste.
    - 2) Clean and flush condenser hotwell and LP drum.
    - 3) Furnish and install new manhole gaskets as required.
    - 4) Repack valves, retighten flanges, tighten valve bonnets, and make repairs and adjustments for all piping systems, equipment, and appurtenances installed under this Agreement at least one time during initial operation.
2. WATER LINE STERILIZATION:
- A. General:
    - 1) Sterilize entire potable water system installed under this Agreement. Sterilize the system from the potable water treatment system connection throughout all potable water pipe lines up to and including fixtures.
    - 2) Provide all required materials including the following:
      - a. High test hypochlorite (HTH) with 65% available chlorine.
      - b. Sterilized pipe, valves, fittings, and accessories.
  - B. Sterilization:
    - 1) Perform sterilization as follows:
      - a. Flush lines with clean water.
      - b. Make slurry of HTH in separate container.
      - c. Simultaneously add slurry and water to obtain a uniform concentration of 40 ppm of available chlorine throughout the system.
      - d. Maintain system full for 6 hours during which time all valves and faucets shall be operated several times.
      - e. Drain and flush system with potable water until residual chlorine content is not greater than 0.2 ppm.
      - f. Allow system to stand full for 24 hours.
      - g. Draw sample under direction of Owner and designated officials.
      - h. Test sample in approved laboratory for bacterial count, and as directed by health authorities.
    - 2) After sterilization make connections to system with sterilized fittings only.
3. AUXILIARY BOILER DEGREASING:
- A. General:

- 1) Auxiliary boiler degreasing shall be performed by a firm specializing in such services.
- 2) Operate the auxiliary boiler in accordance with manufacturer recommendations.
- 3) Perform after boiler is ready for first fire and filled to a level recommended by the manufacturer.
- 4) Degrease with tri-sodium phosphate of a concentration suitable for degreasing boilers and in accordance with chemical and boiler manufacturer's recommendations.
- 5) Chemical shall be completely dissolved in demineralized water before being placed in the boiler.
- 6) Contain and dispose of offsite all boiler degreasing wastewater including blowdown during degreasing process.

B. Procedure:

- 1) Fire boiler to achieve an operating pressure/temperature recommended by the boiler manufacturer.
- 2) Duration of degreasing shall be as required to remove all oil and grease from the boiler. Intermittently fire the boiler as required to achieve cleaning.
- 3) Blowdown the upper and lower drums, and miscellaneous drain valves at least every 8 hours, and add demineralized water as required to maintain adequate drum level.
- 4) Continue until no visible oil or grease is present in the blowdown as determined by Owner.

3. STEAM LINE BLOWDOWN:

A. General:

- 1) Clean each Heat Recovery Steam Generator (HRSG) and steam lines with steam with low pressure, high velocity continuous blows to completely clean the lines to the satisfaction of Owner.

Provisions shall be made to thermally shock the steam lines without affecting the steam drums.

Blowdown steam lines in accordance with a schedule approved by Owner. Owner will notify the proper authorities of the time and duration of the blows.

Contractor shall design the temporary steam blow system and shall furnish and install all temporary piping, silencers test targets (coupons), valves, thermocouples, pressure gauges, anchors, and supports required for blowing steam lines as indicated on the drawings and as required.

Discharge of steam blows will not enter the condensate system.

- 2) Furnish all labor and attendance, and pay all expense for overtime work required to blow steam lines and install or remove temporary pipe, valves, and related items between blowing sequences. Blow steam lines around the clock including weekends and holidays if so directed by Owner. Contractor shall be responsible for obtaining permitting for such work, if necessary.
- 3) Steam line blowdown shall be performed by a firm specializing in such services.
- 4) System Design:
  - a. The temporary pipe and silencer shall be sized to provide a cleaning mass ratio of 1.5 through the steam system. The cleaning mass ratio is defined as:

Rev. 0

$$C.R. = \frac{M_B^2 V_B}{M_D^2 V_D}$$

where  $M_B$  is the main steam flow during steam blow,  $V_B$  is the steam specific volume measured at the superheater outlet,  $M_D$  is the design operating main steam flow, and  $V_D$  is the design operating specific volume.

- b. Steam line conditions for determining the cleaning mass ratio shall be provided by Contractor for Owner review.
- c. Contractor shall submit calculations verifying the cleaning mass ratio at the superheater outlet and at the highest velocity on the main steam line, attemperation water flow rates required, and condensate makeup water flow rates required.
- d. System shall be designed to inject water in the temporary vent piping and the vent silencer to reduce the steam velocity and temperature. Contractor to provide temporary piping from the construction water system to the injection points. All valves, piping and fittings shall be furnished by the Contractor.
- e. Additional attemperation water will be supplied through temporary feedwater attemperation lines installed by this Agreement to shock the steam lines through steam attemperation. Contractor shall provide any temporary piping hose fittings, or equipment required to supply attemperation water to the steam line connections required for thermal shocking.
- f. Steam blow test coupons shall be installed in the temporary piping upstream of final quenching water. Test coupon shall be designed for quick and easy removal and inspection and insertion into the temporary piping.
- g. Steam line blowdown test coupon acceptance criteria shall be as follows:
  - h. No raised impacts shall be visible.
  - i. No greater than three visible impacts for two consecutive steam line blowdown cycles.
  - j. All temporary piping hanger to supports shall be designed in compliance with SECTION 5 of this Specification.
  - k. Test coupons shall be made available to Owner 30 days prior to conducting the steam line blowdown.
  - l. A temporary silencer shall be utilized and shall be designed for a maximum steam velocity of 50 ft/min. Silencer shall be capable of limiting the steam discharge sound pressure level to 85 dBA at 100 feet from the silencer. Silencer location shall be such that the silencer exhaust plume will not impact existing structures or electrical lines. Silencer location shall be located a significant distance from the steam turbine building (minimum of 75 feet) and shall be subject to the approval of Owner.
- m. Contractor shall supply mobile demineralizer as required to provide demineralized water for steam blows. Contractor shall supply temporary hose from the mobile demineralizer to the demineralized water storage tank and/or condenser hotwell.
- n. Demineralized water quality shall be as follows:

- |   |         |
|---|---------|
| (1) Conductivity, micromhos/cm at 25°C, | < 0.15  |
| (2) Sodium, mg/l as Na                  | < 0.003 |
| (3) Silica, mg/l as SiO <sub>2</sub>    | < 0.010 |
| (4) Chloride, mg/l as Cl                | < 0.003 |
| (5) Sulfate, mg/l as SO <sub>4</sub>    | < 0.003 |

Rev. 0



(6) Total Organic Carbon, mg/l as C < 0.100

- o. Wastewater from the Contractor's temporary mobile demineralizer shall be disposed of off site by the Contractor.
  - p. Use test coupons installed in the exhaust lines to indicate when lines are clean. Test coupons shall be 1 inch wide and extend the full diameter of the line being blown. Test coupons shall be made from AISI 1030 brass keystone and shall be ground and polished so that the root mean square surface irregularities does not exceed 16 micro-inches. Lines will be considered clean when test coupons are acceptable to Owner.
- 5) Owner will operate combustion turbine and heat recovery steam generator to generate steam at Contractor specified conditions for steam blows.
  - 6) After Owner acceptance of test coupons, remove all temporary piping, supports, and associated material. Reassemble valves under Owner supervision. The Owner will inspect the existing main steam/hot reheat/cold reheat tie-ins for cleanliness prior to making the final fit-up.
  - 7) At no time is it acceptable for Contractor to make any temporary weld to any critical piping system or associated equipment for support or any other reason, without approval from Owner.

4. STEAM BLOWING SEQUENCE:

A. General:

- 1) Portions of the cold reheat and the low pressure steam line may not be included in the steam blow (at the turbine connections). For sections of piping, which will not be in steam blow, piping shall be received from fabricator clean, shop blasted, and sealed. Contractor shall assume all responsibility in assuring piping is protected against any contamination. Immediately before installation, and upon completion of steam blows, Contractor shall provide means for Owner to perform visual inspection of the piping. Final piping welds shall not be performed until Owner has signed off on all piping inspections.
- 2) Furnish and install temporary steam blow piping, blow valves and silencers.
- 3) Install stop valve blow kits.

B. First Blow

- 1) Steam blowdown will begin after all temporary piping, silencers and demineralized water makeup systems are installed.
- 2) Contractor will operate the combustion turbine to provide a heat source to generate steam from the HRSG. Steam drum pressure will be held constant during the steam line blowdown.
- 3) Install blow kits in the main steam stop valves.
- 4) Furnish and install temporary blow piping from the stop valve to a safe discharge point outdoors. Piping shall include blow valve and silencer.
- 5) Blow from the HP drum through the HP steam piping and the steam turbine HP stop valves, through temporary piping and blowdown valve to exhaust silencer.
- 6) After a period of blowdown, the attemperation water flow shall be increased to shock the main steam line. Steam line shock will be repeated as directed by Owner to enhance cleaning.
- 7) Install test coupons after a period of steam line blowdown.
- 8) The initial blow shall clean from the HRSG through main steam piping and out temporary piping to a silencer. The first stage blow shall be completed only after Owner acceptance of test coupon insertion test result.

Rev. 0

- 9) Blow through HRSG, main steam piping, stop valve, temporary piping, and blowdown valve to atmosphere until clean.
- C. Second Blow:
- 1) Furnish and install bypass piping and temporary blowdown valve from main steam outlet to cold reheat connection at the steam turbine.
  - 2) A temporary connection shall be made to the cold reheat piping at the steam turbine and shall be performed by this Contract.
  - 3) Contractor shall provide temporary attemperation line in the temporary piping between the main steam and cold reheat line to limit the temperature of the steam entering the cold reheat line to the cold reheat design temperature limit.
  - 4) Install blow kits in the hot reheat steam stop valves.
  - 5) Furnish and install temporary blow piping from the stop valve to a safe discharge point outdoors. Piping shall include blow valve and silencer.
  - 6) Contractor shall provide temporary attemperation line in the temporary piping between the main steam and cold reheat line to limit the temperature of the steam entering the cold reheat line to the cold reheat design temperature limit.
  - 7) Blow from the main steam piping, through the main steam bypass to hot reheat piping, hot reheat stop valves and temporary piping to atmosphere until clean.
  - 8) Blow from the IP drum to the cold reheat inlet connection and then blow through the reheater, hot reheat piping, hot reheat stop valves and temporary piping to atmosphere until clean.
  - 9) Blow through main steam piping, through main steam to cold reheat bypass piping, cold reheat piping, to the reheater, hot reheat piping, hot reheat stop valves and temporary piping to atmosphere until clean
  - 10) Blow through main steam piping, stop valve, bypass piping, cold reheat piping, to the reheater, hot reheat piping, hot reheat stop valves and temporary piping to atmosphere until clean.
  - 11) After a period of blowdown, the attemperation water flow shall be increased to shock the reheat steam line. Steam line shock will be repeated as directed by Owner to enhance cleaning
  - 12) Third stage blow shall be completed only after Owner acceptance of test coupon
- D. Third Blow (may occur concurrently with other blows):
- 1) LP steam blowdown will begin after all temporary piping, silencers and condensate makeup systems are installed.
  - 2) Furnish and install temporary blow piping from the strainer upstream of the turbine to a safe discharge point outdoors. Piping shall include blow valve and silencer.
  - 3) Install test coupons after a period of steam line blowdown.
  - 4) The LP steam blow shall clean from the HRSG LP drum through low pressure steam piping and out temporary piping to a silencer. The fourth stage blow shall be completed only after Owner's acceptance of test coupon insertion test result.
  - 5) Blow through LP steam piping, stop valve, temporary piping, and blowdown valve to atmosphere until clean.
- E. Additional Steam Blows:
- 1) Contractor shall blow remaining lines as required for service blows, which shall include at least:
    - a. Main Steam to Combustion Turbine (Power Augmentation Steam Line, if applicable)
    - b. Hot Reheat Bypass to Condenser
    - c. LP Steam Bypass to the Condenser
    - d. Steam cold reheat lines through the Turbine Gland Steam System

Rev. 0

- e. Auxiliary Boiler steam lines through the Turbine Gland Steam System, steam jet air ejectors, condenser sparger, HRSG spargers.
- f. Other steam system lines as designated by the Owner.

5. FUEL GAS LINE BLOWDOWN AND CLEANING:

A. General:

- 1) Clean the fuel gas system by blowing down the main line from the gas metering station to each combustion turbine main inlet with enough blows to completely clean the lines of all foreign matter and to the satisfaction of the Owner and Engineer.
  - a. Blowdown fuel gas lines in accordance with a schedule approved by Owner. Owner will notify the proper authorities of the time and duration of the blows.
- 2) No welding, grinding or other activities that could generate a spark shall be conducted during the blowing operation.
- 3) Perform blowing and line cleaning operations in accordance with Equipment manufacturer's cleaning procedures and as specified herein.
- 4) Blowing procedure shall be developed by Contractor and submitted to Owner for review and approval. Procedure shall blow clean all fuel gas piping from the fuel gas yard to inlet of the filter separators. After this segment is clean, blow from the filter/separators to the combustion turbine accessory modules.
- 5) Blow down piping with at least 4 short duration blows (approx. 15 seconds), then blow with at least 4 medium duration blows (approx. 60 seconds), then blow with long duration blows (approx. 2 minutes) until clean
- 6) Furnish and install all temporary piping, blanking flanges and plates, valves, thermocouples, pressure gauges, anchors, and supports required for blowing fuel gas lines as indicated on the drawings and as required. Remove valve internals and inline flow elements during blowing.
- 7) Install temporary piping to bypass the heat exchangers, knock out tank and filter separator during the initial blows. Remove temporary piping during the final blows and blow through the heat exchangers, knock out tank and filter separator.
- 8) Remove filter separator internals during blowing operations. Inspect and remove all foreign matter from filter separator after blowing operations. Reinstall internals when blowing is completed.
- 9) Furnish and install all required temporary blowdown piping and valves as required to discharge blow gas in a safe location. The temporary blowdown valves shall be equipped with a pneumatic operator with an opening and closing time under pressure not exceeding 10 seconds.
- 10) Gas line blowdown test target acceptance criteria shall be as follows: No visible impacts, pits, dings or holes shall be visible.
- 11) Use test targets installed at the exhaust lines to indicate when lines are clean. Test targets shall be made from 2 foot by 2 foot plywood painted white. Position test target at a 30 or 45 degree angle to the exhaust pipe and position the centerline of the target 2 foot from the exhaust pipe exit.
- 12) Lines will be considered clean when test targets are acceptable to Owner.
- 13) Furnish all labor and attendance, and pay all expense for overtime work required to blow fuel gas lines. Blow fuel gas around the clock and on weekends and holidays if so directed by Owner.
- 14) BELOW: ADD ITEMS 6 THROUGH 15 IF A CONTINUOUS SILENT STEAM BLOW IS DESIRED.
- 15) Fuel gas blowdown shall be performed by a firm specializing in such services.

Rev. 0

- 16) The temporary pipe and silencer shall be sized to provide a cleaning mass ratio of 2.0 through the fuel gas system. The cleaning mass ratio is defined as:

$$C.R. = \frac{M_B^2 V_B}{M_D^2 V_D}$$

where  $M_B$  is the fuel gas flow during gas blow,  $V_B$  is the fuel gas specific volume measured at the fuel gas meter yard,  $M_D$  is the design operating fuel gas flow upstream of the combustion, and  $V_D$  is the design operating main fuel gas specific volume.

- 17) Fuel gas blow test targets shall be installed at the temporary piping exhaust at a safe location as approved by Owner. Test target shall be designed for quick and easy removal and inspection and reinstallation at the exhaust of the temporary piping.
- 18) All temporary piping hanger to supports shall be designed in compliance with this Specification.
- 19) Test targets shall be made available to Owner 15 days prior to conducting the gas line blowdown.
- 20) Owner will furnish the fuel gas for the gas blows.
- 21) After Owner acceptance of test targets, remove all temporary piping, supports, and associated material. Reinstall the filter/separator internals. Reconnection Combustion Turbine Accessory Module. Owner will inspect the tie-ins for cleanliness prior to making the final fit-up.
- 22) After completing blow procedure clean gas piping in accessory module and downstream to combustion turbine injection nozzles. After cleanliness verification by Owner, restore the system when complete.
- B. Gas Blowing Sequence:
- 1) First Blow:
- Bypass the gas fired heat exchangers and hot water heated fuel gas heaters.
  - Furnish and install temporary blow piping including blow valve and silencer and which discharges to a safe point.
  - Blow from the gas yard to the filter/separator inlets until clean.
  - The first stage blow shall be completed only after Owner acceptance of test coupon insertion test result.
- 2) Second Blow:
- Close Bypass and open flow through the gas fired heat exchangers and hot water heated fuel gas heaters.
  - Blow from the gas yard to the filter/separators inlet until clean.
  - The first stage blow shall be completed only after Owner acceptance of test coupon insertion test result.
- 3) Third Blow:
- Install blanking plate at accessory modules.
  - Furnish and install temporary blow piping including blow valve and silencer and which discharges to a safe point.
  - Blow from the gas yard to the accessory module inlets until clean.
  - The third stage blow shall be completed only after Owner's acceptance of test coupon insertion test result

6. INITIAL OPERATION:

A. General:

Rev. 0

- 1) As soon as Contractor's equipment, system or a portion of a system is completed in accordance with Owners defined turnover packages (to be provided after Contract award) and ready for turnover, Owner will perform a walk down of the equipment, system or a portion of a system as follows:
    - a. Contractor shall notify Owner as soon as a system is ready for initial operation.
    - b. Owner will inspect the system to ensure that all work required preparing it for initial operation has been completed.
    - c. As soon as Owner is satisfied that a system has been properly prepared for initial operation, Owner will give Contractor written notice that it is accepted for initial operation. Owner will furnish Contractor an exceptions list for system completion and correcting.
    - d. After acceptance for initial operation, Owner will assume all operational and maintenance duties as defined. All other Contractor's personnel are specifically prohibited from starting or stopping any equipment in the system, opening or closing any valve in the system, operating any switches, breakers or controls in the system, or performing any other operational and maintenance duties whatsoever.
  - 2) When the Owner accepts a system or a portion of a system for operation it will be so marked in accordance with the Project standard marking system (to be provided after Contract Award).
  - 3) After acceptance for operation, Contractor shall continue to provide all specialized personnel and attendance required to correct defective material and workmanship and to perform the Work specified within.
  - 4) Acceptance by Owner of a system or a portion of a system for initial operation does not constitute final acceptance for making final payment nor does it constitute that the system is properly constructed and/or adjusted for proper operation.
  - 5) Contractor shall follow instructions given in manuals supplied by the manufacturer of equipment and materials for erection, installation, cleaning, testing, checkout and start-up.
  - 6) Contractor shall follow instructions of service representative of equipment and materials.
  - 7) Contractor shall cooperate with Owner and manufacturer's service personnel during the start-up period.
  - 8) Contractor shall strictly enforce his own and Owner's safety measures for the protection of equipment and personnel. Owner's tagging procedure shall be strictly complied with.
- B. Equipment and System Turnover Packages:
- 1) The Acceptance for Initial Operation Turnover Package shall contain the following items, and shall be documented in the manner indicated:
    - a. Agreement for Acceptance for Initial Operation form signed by the responsible personnel.
    - b. Table of Contents sheet listing the documents contained in the Turnover Package.
    - c. A copy of the Construction Exceptions List and the Deficiency List with a status of items noted.
    - d. Performance Test data sheets signed and dated by designated personnel.
    - e. Lubrication and alignment data sheets signed and dated by designated personnel.

- f. Marked-up P&ID drawings, electrical schematics and any other drawings necessary to define the system boundaries. All drawings shall be current with all known corrections made prior to Acceptance for Initial Operation.
  - g. List of instruments by instrument number that are within the scope of the system boundaries.
  - h. A list of equipment that is within the scope of the system boundaries.
- 2) System Turnover boundaries shall be established by Owner to reflect functional systems. Each system shall be assigned a system designator by Owner, and Owner will prepare a system turnover schedule. Every reasonable effort shall be made on the part of all responsible parties to turnover systems within the boundaries described on the scheduled date.
  - 3) Approximately six (6) to eight (8) weeks prior to the scheduled turnover date, Contractor shall conduct an informal walkdown of the system with his subcontractors and Owner. This early informal walkdown will define the system boundaries. The informal walkdown shall mark the beginning of the Construction Exception and Start-up Deficiency listing process. One (1) to two (2) weeks prior to the scheduled turnover date, Contractor shall perform a final pre-turnover walkdown. An official Exception List and a Deficiency List shall be prepared at this time. These Lists are to be agreed upon by all parties as exceptions to the system turnover. Those items that Owner indicates must be completed prior to turnover shall be so noted on the Construction Exception List.
  - 4) Once the proper signatures have been affixed, the package will be transmitted to Owner for review and acceptance. Owner will also review the turnover package. If accepted by Owner, Contractor shall release all Construction safety tagging within the boundaries of the turnover and Owner shall affix tags/labels where necessary to signify jurisdictional transfer to Owner. If necessary, the Turnover Package shall be returned for completion to Contractor with a written description of outstanding items.
  - 5) When performing the final walkdown between Owner and Contractor, all known exceptions shall be clearly identified and documented. All exceptions shall be noted on the up Deficiency List or on the Construction Exception List. Control of the Exception List shall be as follows:
    - a. Exception List shall be numbered in accordance with the turnover schedule.
    - b. Owner shall maintain control of the both Exception and Deficiency Lists until completed.
    - c. The Construction Exception List and the Deficiency List with estimated completion dates for open exceptions shall be transmitted to Owner with the Turnover Package.
    - d. Contractor shall meet scheduled completion dates for turnover exceptions and notify Owner of each item completed.
    - e. Contractor shall contact Owner to obtain safety tag clearance as required for completion of turnover exception items.
    - f. Contractor shall document the completion of each exception on the list.
    - g. Contractor shall, as required, transmit copies of updated Exception Lists to Owner.
  - 6) Once Owner accepts the Turnover Package, Owner will place Owner tags or labels on all major valves, boundary valves, breaker panels and breaker panel control switches, various control switches, instrument and instrument panels and other components as necessary to identify boundaries and equipment within boundaries. Once tags are hung, no Contractor personnel shall be permitted to operate or otherwise work on the equipment under tags unless clearance is

Rev. 0

obtained from Owner. All boundary valves or breakers shall be safety tagged to prevent Owner from interfering with construction activities. Turnover from Contractor is not complete until tagging is complete. Tags or labels indicate jurisdictional transfer only. These are not to indicate safety protection for personnel or protect equipment from accidental damage. If protection for personnel or against equipment damage is deemed necessary by Contractor or Owner, the appropriate safety tags will be hung in accordance with a Safety Tagging Procedure.

7. PERFORMANCE AND ACCEPTANCE TESTS:

A. Summary

1. All Performance and Acceptance Tests shall be witnessed by the Owner. Contractor will provide reasonable notice to Buy of any the above tests.
2. Contractor or its sub-Contractors shall Contractorconduct the Performance Tests associated with both Substantial Completion and Final Completion of the Facility.
3. This Section specifies the requirements for Performance Tests of the Facility and Materials and Equipment demonstration tests. Before performing any Facility Performance Tests for capacity and heat rate, the Emissions Test and Noise Level Test shall be performed. The Emissions Test is performed to demonstrate that the Emissions meet the Emissions Guarantee and requirements of the air permit. The Noise Level Test is performed to demonstrate that either the Noise Level Guarantee is met or any failure to achieve the Noise Level Guarantee does not preclude Owner from operating the Facility. The test procedures shall include correction curves for operating conditions which vary from guarantee, including, but not limited to, ambient air temperature, ambient air pressure, ambient air humidity, fuel constituent analysis, generator power factor, steam generator blowdown rate, make-up water conditions, and fuel supply temperature and pressure.
4. Acceptance and performance tests will be conducted by Contractor as soon as possible after initial operation to meet performance guarantees.
5. Acceptance tests shall include a load rejection test at full turbine-generator load. A full-load turbine trip shall also be demonstrated.
6. Contractor shall furnish, maintain, and remove, all special test equipment and instruments required for the tests which are not part of the permanent installation.
7. Owner will furnish operating labor assistance.
8. Owner will provide fuel up to the quantities specified in the APSA. Additional fuel quantities will be provided by Owner, but subject to reimbursement by Contractor under the APSA.
9. Contractor shall provide services of sound specialist equipped with adequate sound level meters and an octave band noise analyzer to measure the performance of the silencing equipment.
10. Performance tests will be made in accordance with a test method mutually agreed upon by Owner and Contractor.

B. Testing Sequence and Schedule

1. Facility Performance Tests
  - a. Prior to Substantial Completion, Contractor shall conduct a Performance Test that demonstrates at least 95% of the Net Electrical Capacity Guarantee

while operating at a Net Heat Rate of not more than 105% of the Net Heat Rate Guarantee. Improperly operating Materials and Equipment may be corrected by Contractor prior to Performance Tests. The sequence for testing of the Facility and Material and Equipment shall be agreed to between the Parties. Materials and Equipment demonstration testing may be conducted prior to or after Substantial Completion, but must be conducted prior to Final Completion.

- b. If Performance Tests prior to Substantial Completion do not demonstrate 100% of Net Electrical Capacity Guarantee and 100% of Net Heat Rate Guarantee, and 100% of Duct Fired Net Unit Capacity Guarantee, then prior to achieving Final Acceptance of the Facility Contractor shall conduct a final Performance Test to determine final Net Electrical Capacity and Net Heat Rate, and 100% of Duct Fired Net Unit Capacity Guarantee.
- c. Prior to Substantial Completion, Contractor shall conduct Functional Testing of the Facility. The following tests have been successfully completed:
  - 1) Plant Hot Start - Contractor will complete two (2) tests that demonstrate the ability of the Plant to start-up from a hot standby condition (overnight shutdown equivalent, 8 hours or less ) to base load condition (each Gas Turbine at its normal firing temperature limit without duct firing) within 105 minutes.
  - 2) Plant Full Load Capability Test - Contractor will complete one (1) test during a Plant Hot Start test in (i) above that demonstrates the ability of the Plant to reach full duct-fired Plant capability (each Gas Turbine at its normal full load firing temperature limit and the HRSG is duct firing at the maximum duct burner fuel flow for the ambient conditions of the test within 165 minutes.
  - 3) Plant Partial Load Operational Test - Contractor shall demonstrate that the loading on the Plant can be successfully and smoothly transitioned from full load to the OEM's minimum load in 10% load increments. The Plant shall be operated with stable output at each load setting for a period of not less than 60 minutes at each load setting.
  - 4) Plant Shutdown Test - Contractor will complete two (2) consecutive tests that demonstrate the ability of the Plant to safely shutdown from base load condition to a hot standby condition within 45 minutes.
- d. Prior to Final Acceptance, Contractor shall conduct additional Functional and Average Equivalent Availability Testing of the Facility. The following Functional Tests shall have been successfully completed:
  - 1. Plant Cold Start - one (1) test that demonstrate the ability of the Plant to start-up from a cold standby condition (shutdown for 72 hours or more) to base load condition (each Gas Turbine at its normal firing temperature limit without duct firing) within 270 minutes.
  - 2. Plant Warm Start - two (2) consecutive tests that demonstrate the ability of the Plant to start-up from a warm standby condition (weekend shutdown equivalent, or 48 hours) to base load condition (each Gas Turbine at its normal firing temperature limit without duct firing) within 150 minutes.



3. Plant Hot Start - two (2) tests that demonstrate the ability of the Plant to start-up from a hot standby condition (overnight shutdown equivalent, 8 hours or less) to base load condition (each Gas Turbine at its normal firing temperature limit without duct firing) within 105 minutes. In the event the Plant demonstrated a Plant Hot Start time less than or equal to the time in the immediately preceding sentence during the Function Test pursuant to this Section, this Functional Test shall not be a condition of Final Acceptance and shall be deemed satisfied.
  4. 1x1 Operational Test - one (1) test of each Gas Turbine that demonstrates its ability to operate in a 1x1 operating mode. The functional test shall consist of startup from a hot standby condition, operate at full load for two hours (120 minutes), and safely shutdown within a total of 350 minutes.
  5. Full Load Steam Bypass To Condenser - one (1) test that demonstrates the ability of the steam turbine to be tripped off line with the Plant at full load capacity so that the Gas Turbines continue to operate at full load with steam from the HRSGs bypassed to the condenser for a period of not less than four (4) hours.
  6. Auxiliary Boiler Capability Test (if applicable) - one (1) full load capability demonstration test of the ability of the auxiliary boiler to produce a nominal 15,000 lbs/hr of steam. The demonstration may be by the input-output method of boiler testing and utilizing only Plant instrumentation. Results shall be corrected to the boiler vendor's reference conditions and, for purposes of this demonstration, a tolerance equivalent to the test uncertainty shall be applied.
- e. A one-hundred sixty-eight (168) hours Average Equivalent Availability test will be performed as a requirement of Final Acceptance. The test period will be a rolling window interval such that for successful completion of this test, the Average Equivalent Availability during the test run of one hundred sixty eight (168) consecutive hours must not be less than ninety-five percent (95%) ("Guaranteed Average Equivalent Availability").
- f. The term "Average Equivalent Availability" is specifically defined as follows for the purposes of the test:

$$\text{Average Equivalent Availability (\%)} = \frac{A + B + C}{D} \times 100\%$$

Where:

A = Total number of hours that the Plant is available for dispatch or operated with the breakers closed to the station bus (including time required to start up and shut down the Plant) without a load restriction on the Plant imposed by Contractor or a failure of the Plant as covered in "C," below. Actual Plant load will be as determined by Owner.

B = The product of the number of hours that the Plant is available for dispatch or operated with the breakers closed to the station bus (including time required to start up and shut down the Plant) during which Contractor has imposed in writing a load restriction on the Plant multiplied by the percentage of load then allowed.

C = The product of the number of hours that the Plant is operated with the breakers closed to the station bus but is incapable of operating at base load or a lower dispatched load due to failure of Plant equipment in the scope of the Contractor multiplied by the percentage of base load or dispatched load which is actually achievable.

D = Total number of hours of the test period.

- g. The Average Equivalent Availability of the Plant shall be calculated at the end of the test period. If the Average Equivalent Availability of the Plant is equal to or greater than respective the Guaranteed Average Equivalent Availability, the test shall be conclusively deemed successful. If the Average Equivalent Availability of the Plant is less than ninety-five percent (95%) in the test, Contractor shall take appropriate remedial action. Following such remedial action, the test shall be reinitiated and the Average Equivalent Availability will be re-calculated on a continuing basis. Once the required value of the respective Average Equivalent Availability is achieved during the most recent testing period, the test will be deemed successfully completed.

#### **11.1.6 1. Conditions Applicable to the Average Equivalent Availability test**

1. Excluded are outage hours which are not under Contractor's control, including but not limited to those caused by low fuel gas supply pressure, grid frequency variations outside of the operating manuals and instruction manuals, operator error, acts of Owner or its agents or subcontractors, and Force Majeure events.
  - A. Owner shall maintain an operator log sheet, following a mutually agreeable format, indicating in detail performance parameters, cycles, and maintenance actions. Owner shall report key performance parameters on a daily basis to Contractor. Contractor may inspect the operator log sheets. The Contractor, at its own expense, may provide a modem for the purpose of monitoring plant parameters during the tests. The Owner will provide a phone access line for this modem.
  - B. Contractor shall be entitled to have a field representative present during performance of the Average Equivalent Availability tests.
    - 1) For the purposes of conducting these tests, a "Start" shall be deemed to be the period of time from the start of the gas turbine ignition sequence to valves wide open (HP and IP) for the steam turbine. All activities required for these startup and shutdown tests shall be performed through the Plant's Distributed Control System ("DCS") with the exception of any normally expected and routine action taken by an operator. The Plant's DCS shall control, or shall cause to be

Rev. 0

controlled, all Equipment necessary for the safe and reliable operation of the Plant with the exception of Equipment normally controlled manually.

## 2. TESTING STIPULATIONS:

- A. Contractor shall conduct Performance Tests associated with both Substantial Completion and Final Completion of the Facility to demonstrate performance as specified and as guaranteed.
- B. The Contractor will collect base-line data for the Materials and Equipment furnished under this Agreement during the initial operation of the Facility.
- C. Contractor shall be required to abide by the results of the tests, or shall provide all additional Materials and Equipment and instruments, make all preparations, furnish testing personnel, and incur all expenses connected with supplementary Performance Tests. Supplementary Performance Tests shall be scheduled at the convenience of Owner. Owner will observe such supplementary Performance Tests and shall be furnished with a complete set of test data and results. If specified conditions are not met, Contractor shall modify or replace the Materials and Equipment to obtain satisfactory performance.
- D. Contractor shall submit detailed written test procedures for all Performance Tests to the Owner and Engineer for review and approval not later than 120 Days prior to the start of the initial Performance Test.
- E. Contractor shall furnish Owner six (6) hard copies and one (1) electronic copy of all test data sheets, test calculations, and the test report for all tests required herein.
- F. Contractor shall furnish and connect all test instruments required by the ASME codes or other appropriate code or standard, if applicable, in addition to normal Facility instruments. With the exception of those connections and devices needed to demonstrate Contractor has met its Gross Auxiliary Electrical Load Guarantee and Water Consumption Guarantee, Contractor shall ensure that all necessary connections and devices required for the Performance Tests are provided for in the design phase of the Work so that modifications to permanent equipment or systems are not required immediately prior to testing.
- G. Contractor shall make all preparations, furnish all testing personnel, and incur all non-Owner expenses connected with the tests.
- H. Should any Materials and Equipment fail to operate as required, or in case of failure to meet any Contractor guarantees, Owner shall have the right to operate the Materials and Equipment until such defects have been remedied and guarantees met. In the event that defects necessitate the replacement of the Materials and Equipment or any part thereof, Owner shall have the right to operate the Materials and Equipment until such time as new Materials and Equipment are provided to replace the defective Materials and Equipment. Removal of defective Materials and Equipment shall be scheduled at Owner's convenience and discretion, which shall not be unreasonably withheld.
- I. All costs to prepare the Facility for a Performance Test shall be to the Contractor's account.
- J. Instruments shall be calibrated by Contractor before the tests. Calibration is defined as comparison of a test instrument's indication against a known standard. Instrument calibrations, where applicable, may be applied to raw data to calculate test results.
- K. A deadband of 1.0% (+/-0.5%) is applicable to the guaranteed Net Electrical Capacity and Net Heat Rate. In comparison of a test result to the Net Electrical Capacity Guarantee and Net Heat Rate Guarantee, the deadband will be

Rev. 0

superimposed over the guarantee. The Agreement guarantee will be deemed fulfilled if the test result falls within the dead band, or, if outside the deadband, the test result indicates better performance than the Agreement guarantee. No allowances shall be made for instrument uncertainty.

- L. Contractor shall submit degradation curves and calculations for all equipment with the detailed written procedures that shall be used to correct Performance Test results to guaranteed performance conditions, as applicable.
- M. The Performance Guarantees shall apply to a Facility in a new and clean condition. However no adjustments shall be made for operation of the unit(s) under the Contractor's responsibility during the startup and commissioning phase.
- N. If operation and performance of the Facility is unsatisfactory due to any deficiency in Contractor's Work, Contractor shall make repairs and re-perform or replace his Work to obtain satisfactory operation and performance and shall provide evidence satisfactory to Owner that his corrective work has corrected the defective work. Performance improvements arising out of a remedy shall be calculated based on the difference between a Performance Test performed immediately before and another one immediately after a remedy is implemented. Requirements for re-testing due to deficiencies shall be mutually agreed upon by the Parties.

### 3. EQUIPMENT DEMONSTRATION TESTING:

- A. Contractor shall perform demonstration tests of major equipment provided by Contractor or Owner. These tests shall be conducted to verify Contractor Materials and Equipment performance. Materials and Equipment demonstration tests are not Performance Tests, they are the tests and checkouts used during commissioning, which verify that the components are fully operational.
- B. Owner shall receive reasonable notice and the opportunity to witness these tests.
- C. Materials and Equipment demonstration tests shall be conducted using either permanent Facility instrumentation or temporary test instrumentation that is functioning in support of the Facility Performance Test.
- D. At least six (6) month prior to testing, test protocols for Materials and Equipment demonstration tests shall be submitted by the Contractor to be agreed upon by Owner and Contractor. The intent is to determine performance of individual components to serve as a baseline for trending component performance for long term Facility operation as compared to the initial performance.
- E. Materials and Equipment demonstration tests may be conducted concurrently with the Facility Performance Test for Substantial Completion.
- F. The following equipment shall be individually tested:
  - 1) Combustion Turbine Generators
  - 2) Steam Turbine Generator
  - 3) Heat Recovery Steam Generators
  - 4) Cooling Tower
  - 5) Main and Auxiliary Transformers
- G. The test procedure shall include, but not be limited to the following, as a minimum:
  - 1) Administrative procedures
  - 2) Correction curves and sample calculations, including all corrections to be applied, in both manual and electronic spreadsheet formats
  - 3) Sample test data sheets
  - 4) Marked-up P&IDs that show the location of all test instrumentation

- H. Prior to the Performance Tests, all Plant equipment directly associated with cycle performance shall be properly adjusted, calibrated, tuned, and washed, shall be in proper and clean working condition, and shall be functioning within its normal operating range as allowed by the equipment manufacturers.

4. FACILITY NET ELECTRICAL CAPACITY AND NET HEAT RATE PERFORMANCE TESTS:

- A. General: Performance Tests shall be run with three operators and under normal operating conditions with essential equipment in automatic control (i.e., no control system jumpers, forces, alarm bypasses, temporary hookups or special equipment to allow for operation). Safety devices, protective relays, and trips mechanisms shall be checked and confirmed operational. Contractor's testing personnel, as well as representatives of any major equipment supplier whose equipment is being tested or are performing simultaneous tests, will also be present during the conduct of Performance Tests.
- B. Performance Tests should be performed at conditions as close as possible to the reference conditions.
- C. All Performance Testing shall be subject to review and potential re-testing if performance-related control system settings are materially changed after Performance Tests have been run. Performance Test protocols shall incorporate a logical sequence of testing to reduce the potential of control system setting changes being required after related Performance Tests are run (i.e. Gas Turbine emissions and control settings should be complete prior to emissions testing, which in turn should be complete prior to Performance Testing).
- D. Facility Net Electrical Capacity and Net Heat Rate Performance Tests shall be in accordance with applicable ASME PIC test codes specifically PTC-46 "Overall Plant Performance." The Net Electrical Capacity and Net Heat Rate, and BOP Gross Auxiliary Electrical Load Guarantee test procedures shall include correction curves for operating conditions which vary from the Guarantee Conditions, including, but not limited to, ambient air temperature, ambient air pressure, ambient air humidity, fuel constituent analysis, generator power factor, steam generator blowdown rate, makeup water conditions, and fuel supply temperature and pressure.
- E. Facility input/output testing shall be performed in accordance with the following:
  - 1) Performance Tests shall be performed when the Facility is operating in steady-state full load condition without HRSG blowdown.
  - 2) Power output of the gas turbine and steam turbine generators shall be measured with Contractor-supplied permanent Facility electrical metering.
  - 3) Contractor may use the plant side revenue quality meters or provide temporary revenue quality certified meters for the measurement of net plant output. If Contractor provides temporary meters, measurement shall be performed at the high side of the step up transformers for station net power and the high side of the auxiliary transformers for the calculation of auxiliary power.
  - 4) Contractor may also use the plant revenue quality metering system to calculate plant net output and station auxiliary power. Meters are provided for each generator and auxiliary transformer. The net plant output is the sum of each generator less auxiliary power less step-up transformer losses. If the meters have been configured a net plant output calculation a direct reading may be

- made. If not, the plant output will be calculated by summing the output of each of the generators, subtracting the auxiliary power and transformer losses.
- 5) Fuel gas mass flow to the gas turbine shall be measured during the Performance Test with the Contractor-supplied orifice plate metering run (in accordance with ASME MFC-3M) installed as a permanent Facility flow meter. Temporary test instrumentation and applicable permanent Facility instrumentation will be used to measure fuel gas temperature, pressure, and differential pressure, as applicable. A minimum of three gas fuel samples shall be taken for analysis during each one-hour test. Natural gas conforming to the OEM's requirements, shall be provided by the Owner during all tests. Natural gas samples will be collected before, during, and at the end of the performance test runs. Both the Contractor and the Owner receive one set of fuel samples. A third set of fuel samples is set aside that can be used in the case of subsequent disputes. A mutually acceptable independent testing laboratory will be used for analysis of natural gas. Test results shall be corrected to the performance gas analysis used for the Performance Guarantees and based on the gas analyses performed on the gas samples taken during testing. The fuel heating value shall be determined by the average value of samples taken during each test run. The cost for sampling and analysis is by the Contractor. If an on-line gas chromatograph is available then these readings may be used as the basis for all evaluations if the Contractor approves. The gas chromatograph unit must, in this case, be properly calibrated prior to the Performance Test, and verification thereof must be made available to the Contractor. The Contractor shall always reserve the right to substitute the laboratory fuel analysis once received for the final test results. All testing and analysis shall be conducted in accordance with appropriate ASME or other mutually acceptable codes.
  - 6) Ambient air temperature shall be measured using laboratory calibrated RTD's or thermocouples installed upstream of the evaporative cooler in the vicinity of the gas turbine air filters. Relative humidity shall be measured at this same location. Barometric pressure shall be measured at a site location away from building structures.
  - 7) Each Performance Test shall consist of three one-hour tests performed within an eight-hour period. Data shall be recorded at intervals in accordance with the agreed upon test procedures. These individual results shall then be averaged for the one-hour period and corrected to Guarantee Conditions. The corrected results of the three one-hour tests shall then be averaged together to determine the performance levels achieved during the Performance Test.
  - 8) The Duct Fired Net Unit Capacity Test will consist of one one-hour run performed as soon as is reasonable after the Net Capacity and Net Heat Rate Test. The results of the Duct Fired Net Unit Capacity test will be corrected to the Guarantee Conditions. If there are any limitations prohibiting full duct firing at the time of the test, then the unit may be operated at part load in order to determine by test the maximum added capacity by duct firing. In this circumstance, two one hour test runs, consisting of one unfired test run and one fired test run conducted at the same load, will be required.
- F. The Performance Tests shall be conducted as described above and the measured performance shall be corrected to Guarantee Conditions. One set of correction curves will be developed per PIC 46 for the Net Electrical Capacity Guarantee, Net Heat Rate Guarantee, and BOP Gross Auxiliary Electrical Load Guarantee.
- 1) If the corrected Net Electrical Capacity is less than the Net Electrical Capacity Guarantee or if the corrected Net Heat Rate is greater than the Net Heat Rate

Rev. 0

- Guarantee, the Facility shall be considered unacceptable and the Contractor shall take appropriate action as indicated elsewhere in this Contract.
- 2) At the conclusion of the Performance Test, the Contractor shall perform calculations to determine performance relative to the Performance Guarantees and shall issue a report covering the entire testing program.

5. EMISSIONS MONITORING AND SAMPLING:

- A. HRSG stack Emissions will be measured using U.S. EPA methods. Emissions Guarantees are as specified in project air permit. U.S. EPA Method 25A/18 will be used for measuring VOC. U.S. EPA Conditional Test Method 27, will be used to measure ammonia slip (NH<sub>3</sub>). U.S. EPA Method 20 for NO<sub>x</sub> and U.S. EPA Method 10 for CO will be used to show compliance with Unit Emissions Guarantees. Method 201A and 202 will be used for measuring particulates, and Method 9 will be used for opacity.
- B. A certified CEMS is defined as a CEMS that has been installed, calibrated, tested and maintained in accordance with the requirements 40 CFR part 75 and Part 60.

6. NOISE TESTING:

- A. After the Facility is placed into successful operation and before Substantial Completion, Contractor shall perform a Noise Level Test on the Facility and Materials and Equipment to verify compliance with Section 1.
- B. Appropriate corrections, in accordance with recognized industry standards, shall be made to the operating plant sound level measurements.

7. WATER CONSUMPTION TEST:

- A. During Performance Tests, Contractor shall demonstrate, using Contractor supplied flow measuring equipment and temporary measuring equipment, that the process Water Consumption Rate does not exceed the process Water Consumption Rate Guarantee provided by the Contractor.

EXHIBIT 8

**Performance Test Completion Certificate**

Contractor, under the Agreement dated \_\_\_\_\_, 20\_\_\_\_, between Contractor and Owner for the Facility hereby certifies that on the \_\_\_ Day of \_\_\_\_\_, 20\_\_\_\_ the Contractor has completed a Performance Test [run or rerun]. A copy of these Performance Test results is attached hereto as Attachment A. The Performance Test [run or rerun, is or is not] the final such Performance Test to demonstrate Facility performance. [Additional or No additional] Performance Testing shall be performed.

Contractor has/has not achieved the Performance Guarantees.

Contractor has/has not achieved the Minimum Performance Standards.

IN WITNESS WHEREOF, Contractor has executed and delivered this certificate through its duly authorized representative as of the \_\_\_\_\_ Day of \_\_\_\_\_, 20\_\_\_\_

By: \_\_\_\_\_

Title: \_\_\_\_\_



**EXHIBIT 8**

**Performance Test Completion Certificate**

**ACCEPTANCE OF PERFORMANCE TEST COMPLETION CERTIFICATE**

Owner hereby accepts the foregoing certificate and confirms that acceptance of this certificate constitutes acknowledgment by the Owner of the level of performance achieved by the Facility.

Owner's Representative hereby accepts the foregoing certificate and confirms that acceptance of this certificate constitutes acknowledgment by the Owner of the level of performance achieved by the Facility.

Contractor hereby accepts the foregoing certificate and confirms that acceptance of this certificate constitutes acknowledgment by the Owner of the level of performance achieved by the Facility.

IN WITNESS WHEREOF, Owner's Representative and Contractor have caused this Acceptance of Performance Test Certificate to be executed by their duly authorized representative as of the \_\_\_\_ Day of \_\_\_\_\_, 20\_\_

OWNER'S REPRESENTATIVE

OWNER

By: \_\_\_\_\_

By: \_\_\_\_\_

Title: \_\_\_\_\_

Title: \_\_\_\_\_

CONTRACTOR

By: \_\_\_\_\_

Title: \_\_\_\_\_



**APPENDIX A**  
**ABBREVIATIONS**

## LIST OF ABBREVIATIONS

ac	alternating current
AGC	automatic generation control
ARMA	Air and Radiation Management Administration
ASCE	American Society of Civil Engineers
ASME	American Society of Mechanical Engineers
Btu	British thermal unit
°C	degree Centigrade
CEMS	continuous emissions monitoring system
CO	carbon monoxide
CO <sub>2</sub>	carbon dioxide
CPCN	Certificate of Public Convenience and Necessity
CRT	cathode ray tube
GT	gas turbine
GTG	gas turbine-generator
dBa	decibel
dc	direct current
DCS	distributed control system
DNR	Department of Natural Resources
EAF	equivalent availability factor
EPC	engineering/procurement/construction
EPA	Environmental Protection Agency (U.S. unless noted)
°F	degree Fahrenheit
FAA	Federal Aviation Administration
FERC	Federal Energy Regulatory Commission
gal	gallon
GNP	Gross National Product
gpd	gallons per day
gpm	gallons per minute
Hga	mercury absolute
HHV	higher heating value
HP	high pressure
hp	horsepower
hr	hour(s)
HRSG	heat recovery steam generator
HVAC	heating, ventilating and air conditioning
Hz	hertz

I&C	instrumentation and control
in	inch(es)
IP	intermediate pressure
ISO	International Standards Organization
kV	kilovolt(s)
kVA	kilovoltampere(s)
kW	kilowatt(s)
kWh	kilowatt-hour(s)
lb	pound(s)
lb/hr	pounds per hour
LHV	lower heating value
LNG	liquid natural gas
LP	low pressure
mA	milliampere(s)
MCC	motor control center
MCR	maximum continuous rating
mgd	million gallons per day
MMBtu	million British thermal units
MVA	megavoltampere
MW	megawatt(s)
MWa	megawatt(s)
MWe	megawatt(s) electrical
MWh	megawatt-hour
NO <sub>2</sub>	nitrogen dioxide
NEPA	National Environmental Policy Act
NFPA	National Fire Protection Association
NO <sub>x</sub>	oxides of nitrogen
NSPS	new source performance standards
O <sub>2</sub>	oxygen
O&M	operation and maintenance
PCS	Parallel Condensing System
pf	power factor
PM	particulate matter
PM-10	particulate matter below 10 microns
ppm	parts per million
ppmvd	parts per million by volume, dry
PPRP	Power Plant Research Program
PSC	Public Service Commission
PSD	Prevention of Significant Deterioration

psi	pounds per square inch
psia	pounds per square inch absolute
psig	pounds per square inch gauge
PURPA	Public Utility Regulatory Policy Act
QF	qualifying facility
RH	relative humidity
rpm	revolutions per minute
scf	standard cubic feet
SCR	selective catalytic reduction
sf	square foot
SO <sub>2</sub>	sulfur dioxide
STG	steam turbine-generator
TSP	total suspended particulates
UL	Underwriters Laboratory
UPS	uninterruptible power supply
V	volt
VAR	volt ampere reactive
VOC	volatile organic compounds



**APPENDIX B**  
**ACCEPTABLE VENDORS LIST**

Exhibit A

7/10/2006  
Rev. B



**APPENDIX B**  
**APPROVED VENDORS LIST**

## Approved Vendors List

Equipment / Construction Package	Approved Subcontractors / Equipment Suppliers
<b>Steam Turbine</b>	<i>Toshiba (TBD)</i> <b>GE</b> Mitsubishi Siemens Alstom
Combined Main Stop and Control Valve/Actuator	Rexroth
Combined Reheat Valve Actuator	Rexroth
Gland Steam Condenser	Southern Heat Exchanger ITT Industries Struthers Industries Krueger Engineering & Mfg. Co.
Gland Steam Exhauster	Gardner Denver The New York Blower Co. Chicago Blower Co. or Equivalent
Main Oil Cooler	Tranter PHE (E) Southern Heat Exchanger ITT Industries GEA Ecoflex (E) Alfa Laval
Oil Conditioner	Kaydon TORE
Oil Mist Eliminator	Burgess-Miura Co. (E) Koch-Otto York
Actuator	<b>Limitorque - Preferred</b> Rotork
<b>Steam Turbine Generator</b>	GE Siemens Alstom <i>Toshiba (TBD)</i>
Turbine Supervisory Instrumentation Unit	Bently Nevada
Position Switch	Namco Co.
Position Transmitter	M-System
Flow Indicator	Yokogawa Electric Co.
Purity Analyser	<b>Yokogawa PacifiCorp Standard</b>
Solenoid Valve	Asco, Co.
Positioner	Fisher Co.
Instrument Valve	<b>Swagelok, Co. - Preferred</b> <b>Whitey Co. – Preferred Valves</b>
Instrument Fittings	<b>Swagelok, Co. - Preferred</b> Whitely Co.
Control Valve	<b>Fisher Co. – Preferred</b>
I/P Converter	Yokogawa
Instrument Rack/Generator	<b>E-One – PacifiCorp Standard</b>
Seal Oil Gauge Panel	<b>E-One – PacifiCorp Standard</b>
Hydrogen Gas Measuring Rack	<b>E-One – PacifiCorp Standard</b>
Generator Condition Monitor	<b>E-One, GCMX – PacifiCorp Standard</b>
H2 Gas Dryer	LectroDryer
<b>Combustion Turbine (</b>	GE Siemens
Generator	GE Siemens
Cooling Tower	SPX (Marley) GEA Midwest Towers, Inc International Cooling Tower

<b>Equipment / Construction Package</b>	<b>Approved Subcontractors / Equipment Suppliers</b>
HRSGs	Deltak Corporation Nooter/Ericksen Vogt Power Alstom
HRSG Duct Burners	Coen Forney John Zink
SCR and CO Systems	Peerless Mfg. Hitachi Vector
SCR Catalyst	Cormetech Hitachi (aka BHK) Argillon (formerly Siemens)
CO Catalyst	Engelhard EmeraChem
Auxiliary Boiler	Babcock & Wilcox Nebraska
Boiler Feed Pumps and Motors	<b>KSB, Inc. - Preferred</b> Sulzer Pumps Weir Pumps Ltd.
Condensate Pumps and Motors	Flowserve Johnston Pump Company Weir Pump Company Sulzer Pumps Goulds Pumps KSB
Circulating Water Pumps and Motors	Flowserve Johnston Pumps Weir Pump Company Sulzer Pumps Goulds Pumps
Condenser, Wet Surface	Alstom Graham TEI Yuba Holtec International SPX (Marley)
Condenser, Air Cooled (ACC)	SPX (Marley) GEA
Heat Exchangers, Plate & Frame	Alfa Laval APV Graham Tranter
Water Treatment Systems (Demin)	Graver Water Co. Hungerford & Terry, Inc. US Filter GE Water Technologies (Glegg) Water and Power Technologies Ecolochem
Oil Water Separators	Anderson Great Lakes Environmental Highland Tank PS International (E)
Air Compressors	<b>Atlas Copco – Preferred</b> Ingersoll Rand Gardner Denver Sullair Cooper/Joy Industries Dresser

Equipment / Construction Package	Approved Subcontractors / Equipment Suppliers
Air Dryers	Kemp <b>Atlas Copco - Preferred</b> Ingersoll Rand Pneumatic Productions Corporation Sullair GDI Deltech
Fuel Gas Treatment	Anderson Separator/Clark Reliance/National Filtration Burgess Manning Flowtronex Gas Packagers GTS Energy Hanover Smith Oil & Gas Systems Peerless Total Energy Resources Tran-Am Universal Compressors
Miscellaneous Horizontal Pumps	Aurora Pumps Flowserve Goulds Pumps Peerless Aurora Sulzer Johnston KSB
Pumps, Vertical	Aurora Pumps Goulds Pumps Flowserve Johnston
Vacuum Pumps	Graham Manufacturing Nash Nitech
Sump Pumps (Submersible)	Aurora Pumps Flygt Corporation Warman Nagel Goulds Flowserve Johnston Pumps
Pumps, Fire Water	Peerless ITT Allis Chalmers Pump Aurora Pumps Fairbanks Morse
Steam Conditioning Valves (attemporators)	CCI Emerson/Fisher-Rosemount Con-Tek
Fire Protection System	F.E. Moran <b>Delta Fire Protection – Salt Lake City -Preferred</b> Grinnell Fire Protection McDaniel Fire System Shambaugh S&S Sprinkler Dooley Tackaberry Securiplex International Fire Protection
GSU Transformers and Unit Auxiliary Transformers	ABB Alstom <b>GE/Prolec - Preferred</b> VA Tech <b>Waukesha – Preferred</b>

<b>Equipment / Construction Package</b>	<b>Approved Subcontractors / Equipment Suppliers</b>
Switchgear	<b>GE – Preferred 4160V</b> <b>Square D – Preferred 480V</b> Powell (Only if part of package) <b>Cutler-Hammer – 4160V and 480V</b>
Motor Control Centers	Powell (Only if part of package) <b>Allen Bradley – Preferred for 480V MCC, 4160V MCC</b> <b>Cutler-Hammer – Preferred for 480V MCC, 4160V MCC</b>
Variable Frequency Drives	Allen-Bradley Safronics Cutler-Hammer Danfoss
Isolated Phase Bus Duct	ABB Calvert <b>Delta-Unibus - Preferred</b> <b>GE Canada - Preferred</b> Hitachi
Non Segregated Phase Duct	Calvert Square D <b>Delta-Unibus - Preferred</b> <b>Powell - Preferred</b>
Power Control and Instrumentation Cables	BICC Rockbestos Supernaut Tamaqua Pirelli <b>Okonite - Preferred</b> Furon/Dekoron Rome <b>Southwire - Preferred</b> <b>Belden – Communication Cable Preferred</b> Kerite
High and Medium Voltage Cable	Pirelli <b>Okonite - Preferred</b> Rome Kerite
<b>Distributed Control System</b>	<b>Siemens T3000</b>
Continuous Emissions Monitoring System	<b>KVB Enertec DAHS Software; and PacifiCorp specified instruments – PacifiCorp Standard</b>
Chemical Feed Systems	Liquitech, Inc. Neptune JCI Wadsworth Pumps Flowtronex <b>Milton Roy/LMI or Micro Pump – Preferred</b> Nalco Johnson March Systems, Inc. Sentry Equipment
Water Sample Panel	Delphi Control Systems Johnson March Systems Sentry Equipment Corp. Waters Equipment Co.
<b>Instrumentation Analytical Measurements</b>	
Chromatographs	ABB Daniel (Natural Gas) EG&G Rosemount
Conductivity	<b>Yokogawa – PacifiCorp Standard</b>
Oxygen	<b>Orbisphere/Hach or Yokogawa – PacifiCorp Standard</b>
Silica	<b>Hach – PacifiCorp Standard</b>
Sodium	<b>Orion – PacifiCorp Standard</b>

<b>Equipment / Construction Package</b>	<b>Approved Subcontractors / Equipment Suppliers</b>
pH Probe	<b>Yokogawa – PacifiCorp Standard</b>
Vibration	<b>Bentley Nevada – PacifiCorp Standard</b>
Chlorinators	Advance Capital Controls Fischer & Porter Wallace & Tieman
Computers (Flow)	Daniel Omni Fisher
Controllers, Field Mounted, Pneumatic	Fisher
Flame Supervisory Systems	Fireye Forney Honeywell Allen Bradley Iris (E)
Indicators Manometers	<b>Dwyer – preferred</b> Meriam
Indicators Press/Receiver Gauge	<b>Ashcroft – Preferred (Except in the case of pre-packaged equipment)</b>
PLC	<b>Allen Bradley - PacifiCorp Standard (Except in the case of pre-packaged equipment) Control Logix or SLC 5/05 (Ethernet Version)</b>
<b>Transmitters, Electronic</b>	
Differential Pressure	<b>Rosemount - PacifiCorp Standard (Except in the case of pre-packaged equipment)</b>
<b>Level Measurement</b>	
Capacitance, Etc.	Drexelbrook Fisher
Displacement	Fisher
Process Radar	Rosemount Ohmart-Vega
Custody Transfer/Radar/Displacement	Enraf Saab
Radioactive	Kay-Ray Ohmart-Vega Texas Nuclear
Ultrasonic	Endress & Hauser Inc. Kistler Morse Magnetrol Millitronics
TDR	Magnetrol <b>Rosemount – preferred</b>
Magnetic Flow	<b>Rosemount – preferred</b>
Mass Flow	ABB/Bailey <b>Rosemount – preferred</b>
Pressure	Foxboro Honeywell Yokogawa <b>Rosemount – preferred</b>
Target Meter	Foxboro Hersey Measurement
Temperature	Foxboro Moore Industries <b>Fisher-Rosemount – preferred</b> Honeywell Yokogawa
Turbine	Daniel Foxboro

<b>Equipment / Construction Package</b>	<b>Approved Subcontractors / Equipment Suppliers</b>
<b>Transmitters, Pneumatic</b>	
Differential Pressure	<b>Fisher – preferred</b>
Level Displacement	Fisher Magnetrol
Pressure	Fisher Foxboro
Target Meter	Foxboro
Temperature	Fisher-Rosemount Foxboro
UPS	Best SCI
<b>Valves and Regulators</b>	
Actuators, Diaphragm	<b>Fisher – PacifiCorp Standard (Except in the case of pre-packaged equipment)</b>
Actuators, Piston	Automax Bettis Contromatics George-Fischer Hills-MC Canna Neles-Jamesbury Posacon Valtek Vanton Whitey XACT
Control Valves – ON/OFF or Throttling Ball	<b>Fisher – preferred</b> Atwood & Morrill (E) Copes Vulcan Maseoilan Neles-Jamesbury TYCO (E) Valve Technologies Watts WKM
Positioners, Electric	<b>Limitorque, MX – Preferred</b> Fisher-Rosemount Auma
Butterfly/ECC Disk	AMRI Continental Durco Fisher-Rosemount Maseoilan Moisten Neles-Jamesbury Valtek
Valves, Butterfly <24-inch	Bray Valves & Controls Dezurik Flowseal Henry Pratt Co. Jamesbury Keystone Valve KSB-AMRI
Valves, Butterfly >24-inch	Atwood & Morrill Dezurik Flowseal Grinnell Corp. Henry Pratt Co. Keystone Valve Watts

<b>Equipment / Construction Package</b>	<b>Approved Subcontractors / Equipment Suppliers</b>
Valves, Globe	Atwood & Morrill Edwards Newco Valves Pacific Valves Whitey Yarway
Valves, Cast Steel	Atwood & Morrill Crane Edwards Pacific Valves Tyco Velan Valve Co. WM Powell Co.
Control Valves, Severe Duty, (Bypass, Recirculation, Drum level control, ACC spargers)	<b>CCI – PacifiCorp Standard</b>
Valves, Forged Steel	Edwards Valves, Inc. Conval, Inc. Dresser Industrial Valve Yarway Velan Valve Corp Vog Newco Bonney Forge
Valves, High Pressure	Atwood & Morrill Crane Edwards Pacific Valves Tyco Velan Valve Co.
Valves, Knife-gate	Warman Dezurik Newcon Clarkson
Valves, Check	APCO Crane Edward Valves Pacific Valves Stockham Valves & Fittings Yarway/Tyco
Globe / Cage (No Split Body) 300#	Collins Instrument (Plastic) Fisher Masoneilan Samson Valke Control Component, Inc. (CCI)
Miniature / Special	Collins Instrument Research Controls Whitey
Pinch, Weir, Diaphragm	ASAHI Fisher-Rosemount Grinnell Red Valve RKL
Plug	Durco Tufline
Regulators	Air Service Fisher-Rosemount Process Service Cashco
Strainers, Automatic Flushing	Hayward Strainers



<b>Equipment / Construction Package</b>	<b>Approved Subcontractors / Equipment Suppliers</b>
	Hellan SP Kinney Engineers
Valves, Ball	ITT Engineered Valves Mogas Neles Jamesbury NIBCO, Inc Stockham Valves & Fittings Whitey
Relief or Safety Valves	<b>Consolidated – PacifiCorp Standard for Steam Service</b> Crosby Ferris Dresser
<b>Installation Hardware</b>	
Boxes or Cabinets – Instrument and Junctions Metal	Appleton <b>Hoffman – preferred</b>
Boxes or Cabinets – Instrument and Junctions Fiberglass or Plastic	<b>Hoffman – preferred</b> Stahlin
Cable Tray and Tubing Support Tray Metal	B-Line OBO Betterman PW
Cable Tray and Tubing Support Tray Nonmetallic	Channel Way Enduro Fibergrate Seagate Stahlin
Instrument Manifolds and Valving Assemblies	Anderson Greenwood PGI Rosemount
Tubing Metal	Dekoron Thermoelectric
Tubing NonMetallic	Dekoron Thermoelectric
Fittings (Compression) Metal	Gyrolok <b>Swagelok – Preferred</b>
Fittings (Compression) Non-metallic	JACO (Kynar)
Fittings (Compression) Valves, Metal	Anderson Greenwood Hoke PGI <b>Whitey - Preferred</b>
Wire Signal	Alpha Belden Dekoron
Wire Thermocouple	Dekoron
<b>Other</b>	
Expansion Joints	Bachmann Industries Effox Pathway Wahlco Engineered Products
Fluid Couplings	Voith
Pipe, Circulating Water	Ameron La Barge Pipe McAbee Construction Northwest Pipe Company Dixie Southern
Pipe, Fabricated LP	Bendtec International Piping Systems McAbee Construction Team Industries Scott Process

<b>Equipment / Construction Package</b>	<b>Approved Subcontractors / Equipment Suppliers</b>
Pipe, Supports	Froneck Lisega Bergen PTP
Tanks, Field Erected	CBI Columbian Tank Matrix Pittsburgh Tank Fisher Tank HMT, Inc
Tanks, Shop Fabricated	Arrow Tanks Eaton Modern Welding Palmer Dixie Southern
<b>Equipment/Construction Package</b>	<b>Approved Subcontractors</b>
Fittings (Compression) Metal	Gyrolok <b>Swagelok– preferred</b> Nonmetallic JACO (Kynar)
Fittings (Compression) Valves, Metal	Anderson Greenwood Hoke PGI <b>Whitey – preferred</b>
Tubing NonMetallic	Dekoron Thermoelectric
Wire Signal	Alpha Belden Dekoron
Wire Thermocouple	Dekoron
Protective Relaying Devices and Systems	<b>Schweitzer Engineering Labs, Inc.300 Series – Preferred</b>
Lockout Relays	<b>Electroswitch – PacifiCorp Standard</b>
Test Switches	<b>ABB – Preferred</b> States
Revenue Meters	<b>Landis &amp; Gyr 2510 – PacifiCorp Standard</b>



**APPENDIX C**  
**CONCEPTUAL SITE ARRANGEMENTS**

Exhibit A

7/10/2006  
Rev. B

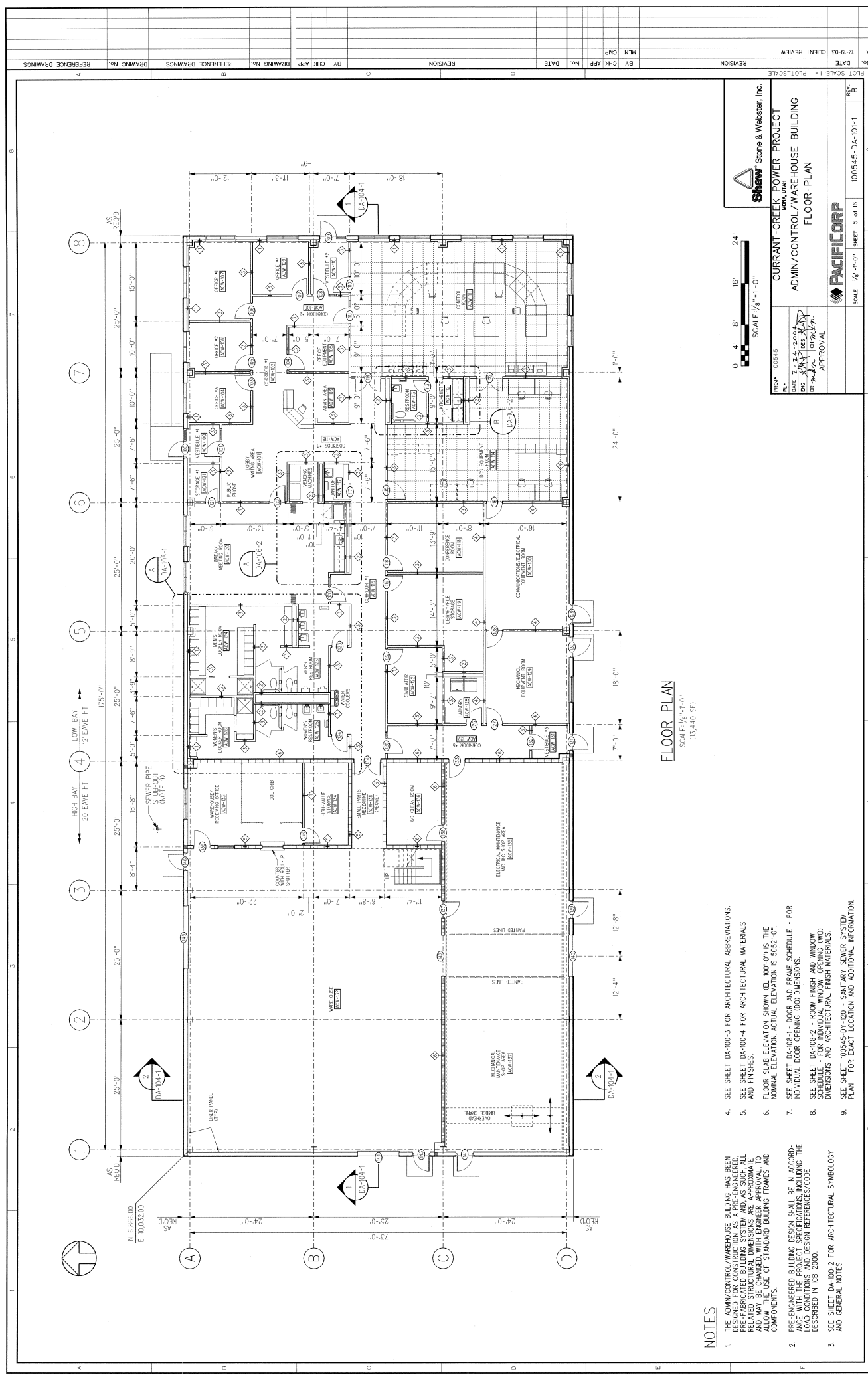

**FLOOR PLAN**  
SCALE: 1/8" = 1'-0"  
(13,446-SF)

**NOTES**

1. THE ADMIN/CONTROL/WAREHOUSE BUILDING HAS BEEN DESIGNED FOR CONSTRUCTION AS A PRE-ENGINEERED BUILDING. ALL DIMENSIONS ARE APPROXIMATE AND MAY BE CHANGED, WITH ENGINEER APPROVAL, TO ALLOW THE USE OF STANDARD BUILDING FRAMES AND COMPONENTS.
2. PRE-ENGINEERED BUILDING DESIGN SHALL BE IN ACCORDANCE WITH THE PROJECT SPECIFICATIONS, INCLUDING THE SCHEDULE - FOR INDIVIDUAL WINDOW OPENING (WD) DIMENSIONS AND ARCHITECTURAL FINISH MATERIALS.
3. SEE SHEET DA-100-2 FOR ARCHITECTURAL SYMBOLLOGY AND GENERAL NOTES.
4. SEE SHEET DA-100-3 FOR ARCHITECTURAL ABBREVIATIONS.
5. SEE SHEET DA-100-4 FOR ARCHITECTURAL MATERIALS AND FINISHES.
6. FLOOR SLAB ELEVATION SHOWN (EL. 100'-0") IS THE NOMINAL ELEVATION. ACTUAL ELEVATION IS 9552'-0".
7. SEE SHEET DA-105-1 - DOOR AND FRAME SCHEDULE - FOR INDIVIDUAL DOOR OPENING (DO) DIMENSIONS.
8. SEE SHEET DA-105-2 - ROOM FINISH AND WINDOW SCHEDULE - FOR INDIVIDUAL WINDOW OPENING (WD) DIMENSIONS AND ARCHITECTURAL FINISH MATERIALS.
9. SEE SHEET 100545-DT-10 - SANITARY SEWER SYSTEM PLAN - FOR EXACT LOCATION AND ADDITIONAL INFORMATION.



**SHAW Stone & Webster, Inc.**  
CURRENT-CREEK POWER PROJECT  
ADMIN/CONTROL/WAREHOUSE BUILDING  
FLOOR PLAN

PROJ: 100545  
DATE: 7-24-2004  
DES: JAY  
CHK: JAY  
APP: JAY



**PACIFICORP**  
SCALE: 1/8" = 1'-0" SHEET 5 of 16 100545-DA-101-1



NO.	DATE	REVISION	BY	CHK	APP	DATE
1	7-24-04	ISSUED FOR PERMIT	JAY	JAY	JAY	
2	7-24-04	REVISED PER COMMENTS	JAY	JAY	JAY	

AM

**NOTES**

1. THE EQUIPMENT SHOWN IS REPRESENTATIVE INFORMATION. THIS DESIGN IS SUBJECT TO CHANGE AT THE DISCRETION OF THE ENGINEER.
2. REFERENCE DRAWING 0980700DS FOR COMBUSTION TURBINE EQUIPMENT DIMENSIONS AND IDENTIFICATION.
3. REFERENCE DRAWING 0980700DS FOR STEAM TURBINE EQUIPMENT DIMENSIONS AND IDENTIFICATION.

- LEGEND**
1. W501F GAS TURBINE ENCLOSURE
  2. W501F GAS TURBINE ENCLOSURE
  3. ROTOR COOLER (MIDDLE BOILER TYPE)
  4. FUEL GAS PREHEATER
  5. HEAT RECOVERY STEAM GENERATOR
  6. HRSG STACK EMISSIONS MONITORING
  7. MOTOR CONTROL CENTER (HRSG - OUTDOOR, NON-WALK IN)
  8. MV SWITCHGEAR/ACC (OUTDOOR, WALK IN)
  9. GENERATOR BREAKER
  10. GENERATOR
  11. TRANSFORMER
  12. MAIN STEP UP TRANSFORMER
  13. SAMPLING STATION
  14. BOILER FEEDWATER PUMP ENCLOSURE
  15. OIL WATER SEPARATOR
  16. SURFACE CONDENSER
  17. COOLING WATER BOOSTER PUMPS(S)
  18. VACUUM PUMPS(S)
  19. CONDENSATE PUMP
  20. POWER CONTROL CENTER (COMMON PART)
  21. POWER CONTROL CENTER (STEAM TURBINE)
  22. SECONDARY UNIT SUBSTATION
  23. COOLING TOWER
  24. LOW VOLTAGE TRANSFORMER
  25. COOLING WATER (CRG. PUMPS(S))
  26. WATER TREATMENT BUILDING
  27. FRESH WATER STORAGE TANK
  28. DRINK WATER FORWARDING PUMPS(S)
  29. COMPRESSED AIR SYSTEM
  30. FIRE PUMPS(S)
  31. RAW WATER FORWARDING PUMPS(S)
  32. WATER STORAGE TANK
  33. CONTROL RM / ADMIN. BUILDING
  34. AMMONIA STORAGE TANK
  35. AMMONIA UNLOADING AREA
  36. PARKING
  37. GATE
  38. FENCE
  39. AUXILIARY BUILDING
  40. AMMONIA STORAGE/WAREHOUSE BUILDING
  41. EMERGENCY DIESEL GENERATOR
  42. INDUSTRIAL WASTE LIFT STATION
  43. COOLING TOWER CHEMICAL FEED ENCLOSURE
  44. CUSTOMER EXPECTED HIGH VOLTAGE COLLECTOR BUS AREA

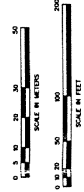
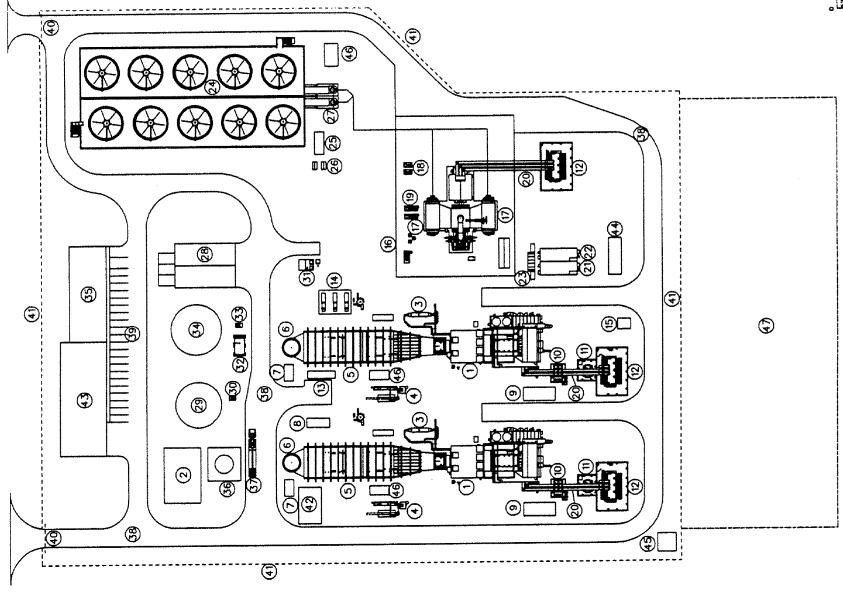

**CONCEPTUAL**

**LAKE SIDE POWER PLANT**

<b>PROPRIETARY INFORMATION</b>		<b>SIEMENS</b> Siemens Westinghouse Power Corporation A Siemens Company	
DATE	2004/06/21	DRAWN	D.A.S.
DESIGNED BY	T. SCHMIDT / L. CARBONELL	CHECKED BY	J.D.
PROJECT NO.	0980700	SCALE	0% / MICRO
CUSTOMER NO.	NE030904	DRAWING NO.	0980700
		SHEET	01
		PAGE	01

**GENERAL ARRANGEMENT  
FACILITY PLOT PLAN**

**2 X 1 W501F COMBINED CYCLE**

Handwritten initials/signature

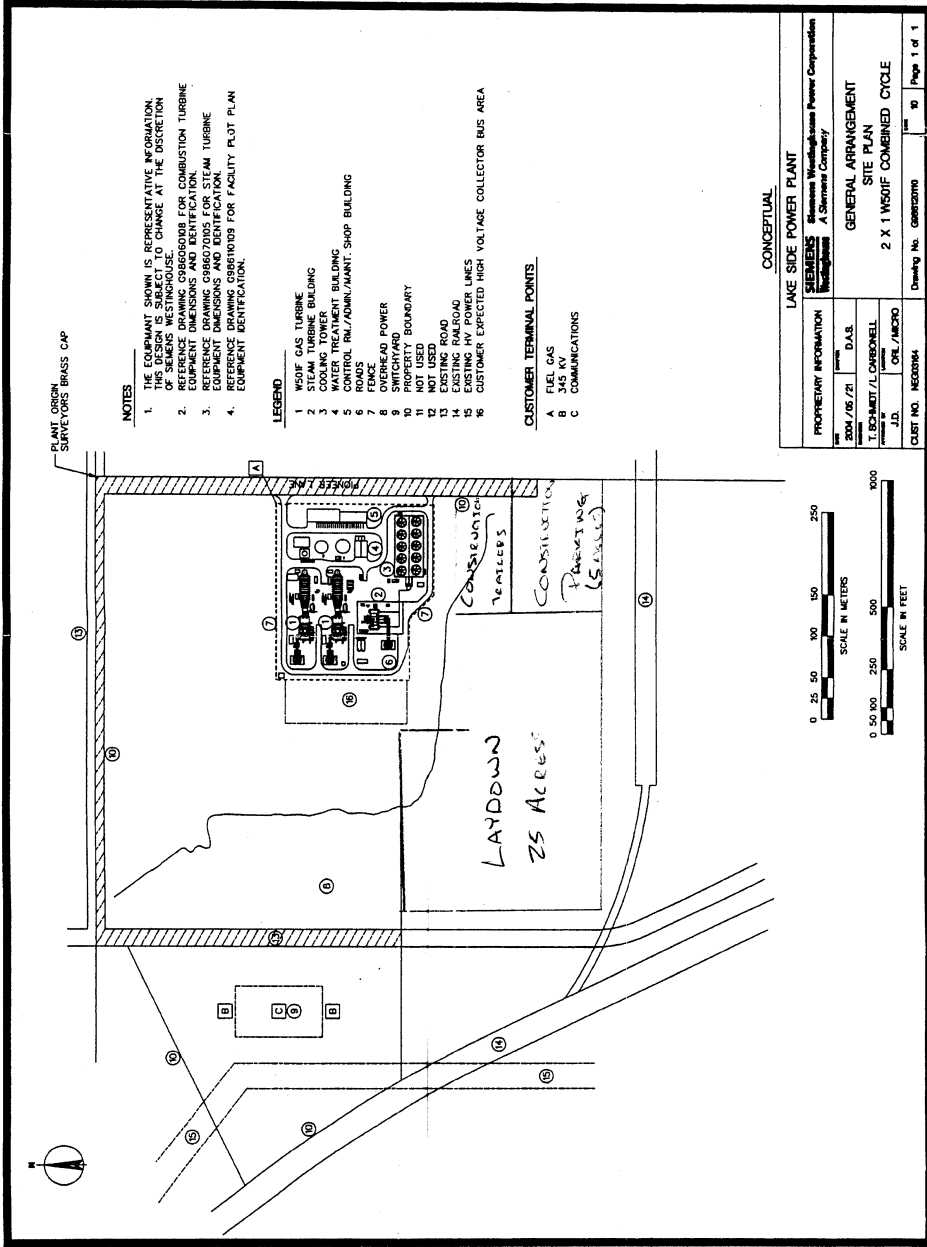

**NOTES**

1. THE EQUIPMENT SHOWN IS REPRESENTATIVE INFORMATION. IT IS SUBJECT TO CHANGE AT THE DISCRETION OF SIEMENS WESTINGHOUSE.
2. REFERENCE DRAWING C98660088 FOR COMBUSTION TURBINE EQUIPMENT DIMENSIONS AND IDENTIFICATION.
3. REFERENCE DRAWING C98660088 FOR STEAM TURBINE EQUIPMENT DIMENSIONS AND IDENTIFICATION.
4. REFERENCE DRAWING C98610109 FOR FACILITY LAYOUT PLAN EQUIPMENT IDENTIFICATION.

**LEGEND**

- 1 WSOIF GAS TURBINE
- 2 STEAM TURBINE BUILDING
- 3 COOLING TOWER
- 4 TREATMENT BUILDING
- 5 CONTROL BUILDING/ADMIN./MAINT. SHOP BUILDING
- 6 ROADS
- 7 FENCE
- 8 SWITCHGEAR POWER
- 9 SWITCHGEAR
- 10 PROPERTY BOUNDARY
- 11 NOT USED
- 12 FOOTING ROAD
- 13 EXISTING RAILROAD
- 14 EXISTING HV POWER LINES
- 15 CUSTOMER EXPECTED HIGH VOLTAGE COLLECTOR BUS AREA

**CUSTOMER TERMINAL POINTS**

- A FUEL GAS
- B 345 KV
- C COMMUNICATIONS

**CONCEPTUAL**

<b>LAKE SIDE POWER PLANT</b>	
<b>SIEMENS</b>	Siemens Westinghouse Power Corporation
<b>WESTINGHOUSE</b>	A Siemens Company
<b>PROPRIETARY INFORMATION</b>	
<b>DATE</b>	D.A.S.
<b>DESIGNED BY</b>	T. SCHMITZ / CARROLL
<b>CHECKED BY</b>	C.R. / MICRO
<b>CUSTOMER NO.</b>	NE000964
<b>DRAWING NO.</b>	00000000
<b>SCALE</b>	10
<b>PAGE</b>	10
<b>TITLE</b>	GENERAL ARRANGEMENT SITE PLAN
<b>DESCRIPTION</b>	2 X 1 WSOIF COMBINED CYCLE

Handwritten note: 09/16/2000





**APPENDIX D**  
**CONCEPTUAL PROCESS FLOW DIAGRAMS AND WATER  
BALANCE**

Exhibit A

7/10/2006  
Rev. B



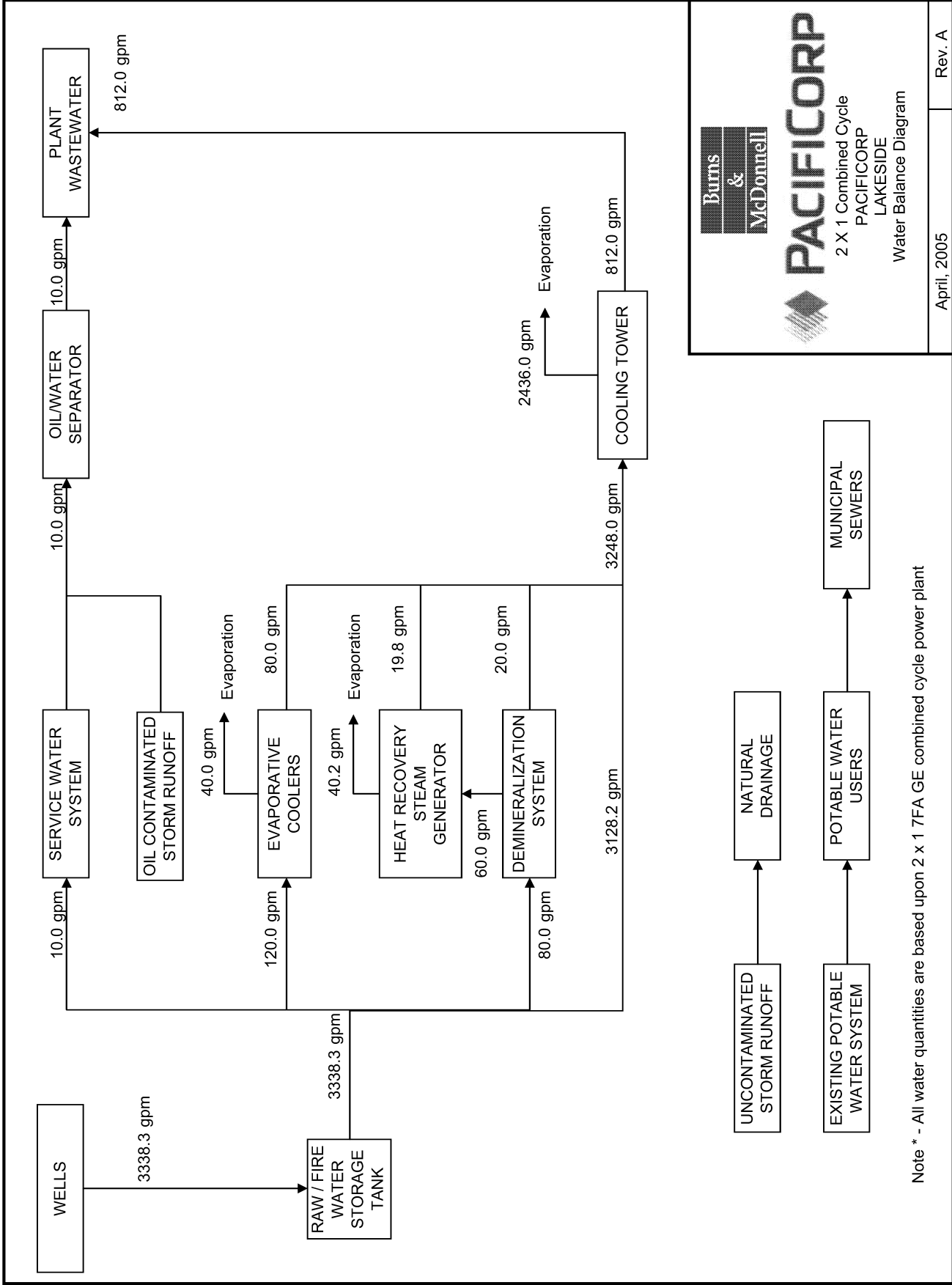

Note \* - All water quantities are based upon 2 x 1 7FA GE combined cycle power plant

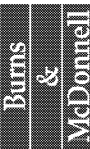
  
**PACIFICORP**  
 2 X 1 Combined Cycle  
 PACIFICORP  
 LAKESIDE  
 Water Balance Diagram

April, 2005 Rev. A



**APPENDIX E**  
**CONCEPTUAL ONE-LINE DIAGRAMS**

Exhibit A

7/10/2006  
Rev. B

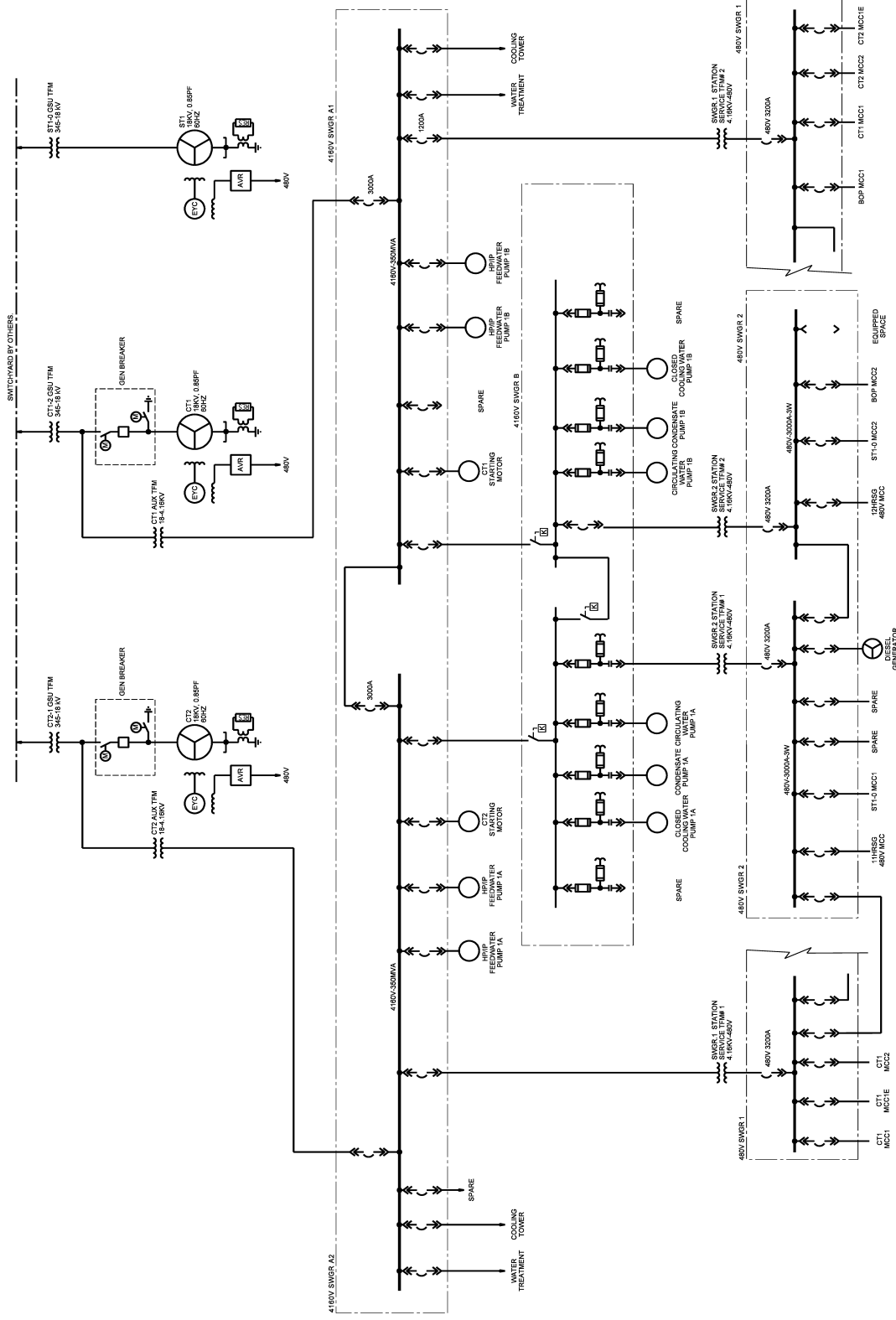

**PACIFICCORP**  
POWER SUPPLY

**LAKE SIDE**  
2 x 1 COMBINED CYCLE  
CONCEPTUAL ONE-LINE DIAGRAM

project 38849  
contract

date APRIL 20, 2005  
designed D. STEPHENS

SKE-1 - 0 rev.

**NOTES:**

- ONE LINE TO BE REVISED TO REFLECT PROPOSED COMBUSTION TURBINE.



**APPENDIX F**

**PACIFICORP – “Material Specification ZS 001- 2004, Substation  
Equipment – Power Transformer All Ratings”**

Exhibit A

7/10/2006  
Rev. B





**APPENDIX G**  
**GEOTECHNICAL REPORT**

Exhibit A

7/10/2006  
Rev. B



**APPENDIX H**  
**LARGE GENERATION INTERCONNECTION AGREEMENT (LGIA)**

Exhibit A

7/10/2006  
Rev. B



**APPENDIX I**  
**MAKE-UP WATER ANALYSIS**

## APPENDIX I

### MAKE-UP WATER ANALYSIS

	Design (Raw) Water Analysis
Calcium, mg/l as Ca	73
Magnesium, mg/l as Mg	11.2
Sodium, mg/l as Na	37
M-Alk, mg/l as CaCO <sub>3</sub>	130
Sulfate, mg/l as SO <sub>4</sub>	15
Chloride, mg/l as Cl	15
Nitrate, mg/l as NO <sub>3</sub>	0.02
Phosphate, mg/l as P	0.012
Silica, mg/l as SiO <sub>2</sub>	18
Barium	0.077
Strontium	0.043
pH	7.5 -8.5
Conductivity, $\mu$ S/cm	310
TDS, mg/l	220
TOC, mg/l	<2
TSS, mg/l	1





**APPENDIX J**  
**FUEL ANALYSIS**

Fuel Gas will be of the following composition.

Natural Gas Analysis	
<u>Analysis (mole %)</u>	
Methane	
Ethane	
Propane	
Iso Butane	
Butane	
Carbon Dioxide	
Nitrogen	
Pentane	
Total Sulfur, grains/ 100 SCF	
<u>Heating Value</u>	
Lower Heating Value Btu/lb	
LHV	



**APPENDIX K**

**DATA TO BE SUBMITTED WITH BID**



SECTION 18049 - GAS TURBINE DATA TO BE SUBMITTED WITH BID: continued

- (2) Exhaust gas flow, lbs/hr \_\_\_\_\_
- (3) Exhaust gas temperature, °F \_\_\_\_\_
- (4) Exhaust gas specific heat, Btu/lb/°F \_\_\_\_\_
- (5) Analysis of turbine exhaust gas, % vol.
  - (a) CO<sub>2</sub> \_\_\_\_\_
  - (b) N<sub>2</sub> \_\_\_\_\_
  - (c) H<sub>2</sub>O \_\_\_\_\_
  - (d) O<sub>2</sub> \_\_\_\_\_
  - (e) VOC \_\_\_\_\_
  - (f) Particulate \_\_\_\_\_
- (6) (Steam) (Water) injection lb/hr \_\_\_\_\_
- c. The net heat rate including all losses and auxiliary power uses will not exceed Btu/kWh (based on (HHV) (LHV) of fuel and net power to step-up transformer
  - (1) Peak load
    - Heat Rate, Btu/kWhr \_\_\_\_\_
    - Load, kW \_\_\_\_\_
  - (2) Baseload
    - Heat Rate, Btu/kWhr \_\_\_\_\_
    - Load, kW \_\_\_\_\_
  - (3) 3/4 load
    - Heat Rate, Btu/kWhr \_\_\_\_\_
    - Load, kW \_\_\_\_\_
  - (4) 1/2 load
    - Heat Rate, Btu/kWhr \_\_\_\_\_
    - Load, kW \_\_\_\_\_
- d. The spinning reserve net heat input will not exceed the following:
  - Heat input, Btu/hr (HHV) (LHV) \_\_\_\_\_
  - At minimum stable operating load of, kW \_\_\_\_\_
- e. The maximum generator capability at \_\_\_\_ volts, 90% power factor, when temp. rises are in

SECTION 18049 - GAS TURBINE DATA TO BE SUBMITTED WITH BID: continued

accordance with ANSI standard C50 will be, kW: \_\_\_\_\_

- f. NO<sub>x</sub> Emissions Control System:
  - (Steam pressure/temperature) \_\_\_\_\_ / \_\_\_\_\_
  - (Minimum quality of water required) \_\_\_\_\_
  - Flow required at peak output, lb/hr \_\_\_\_\_
  - Flow required at base output, lb/hr \_\_\_\_\_
  - Flow required at 1/2 of baseload, lb/hr \_\_\_\_\_
- g. Exhaust Emissions (Corrected to 15% Oxygen):
  - At Peak Rating:
    - CO, ppm by volume \_\_\_\_\_
    - NO<sub>x</sub>, ppm by volume \_\_\_\_\_
    - SO<sub>2</sub>, ppm by volume \_\_\_\_\_
    - VOC, ppm by volume \_\_\_\_\_
    - Particulate, ppm by volume \_\_\_\_\_
  - At Base Rating:
    - CO, ppm by volume \_\_\_\_\_
    - NO<sub>x</sub>, ppm by volume \_\_\_\_\_
    - SO<sub>2</sub>, ppm by volume \_\_\_\_\_
    - VOC, ppm by volume \_\_\_\_\_
    - Particulate, ppm by volume \_\_\_\_\_
- h. Evaporative cooler water requirements:
  - Flow required at peak output, gpm \_\_\_\_\_
  - Flow required at base output, gpm \_\_\_\_\_
  - Flow required at 1/2 of base output, gpm \_\_\_\_\_
  - Minimum water quality required pH \_\_\_\_\_ to \_\_\_\_\_
  - Alkalinity, ppm max \_\_\_\_\_
  - Hardness, ppm max \_\_\_\_\_

B. Other Guarantees:

- 1. Silencing: When operating at baseload service rating, the sound pressure level is decibels to the reference level of 0.0002-microbar at all ground-level locations 3 feet from the unit will not exceed the following (based on 80°F, background noise 10 dB lower all octaves):

SECTION 18049 - GAS TURBINE DATA TO BE SUBMITTED WITH BID: continued

Octave Band	
<u>No.</u>	
1	_____
2	_____
3	_____
4	_____
5	_____
6	_____
7	_____
8	_____
"A" Level	_____

The above values are maximum values and the orientation of maximum sound pressure level is \_\_\_\_\_.

2. Silencing: When operating at baseload service rating, the sound pressure level is decibels to the reference level of 0.0002-microbar at all ground-level locations 10 feet from the air inlet filter will not exceed the following (based on 80°F, below 5 mph wind, and background noise 10 dB lower all octaves):

Octave Band	
<u>No.</u>	
1	_____
2	_____
3	_____
4	_____
5	_____
6	_____
7	_____
8	_____
"A" Level	_____

SECTION 18049 - GAS TURBINE DATA TO BE SUBMITTED WITH BID: continued

The above values are maximum values and the orientation of maximum sound pressure level is \_\_\_\_\_

\_\_\_\_\_  
\_\_\_\_\_

1.02 EXPECTED UNIT PERFORMANCE:

The Bidder shall submit with the Bid the following expected performance data by filling in the blanks provided:

A. Unit Performance Guarantees:

1. Unit Operating Conditions:

Gas Turbine Inlet: Wet Bulb \_\_\_\_\_ °F  
Dry Bulb \_\_\_\_\_ °F  
Bus Voltage: \_\_\_\_\_ volts  
System Power Factor: 90%  
Evaporative Cooler Operating: (Yes) (No)  
Fuel: Natural Gas

- a. Base net output rating of turbine-generator, kW \_\_\_\_\_
- (1) Fuel Input, MMBtu/Hr (HHV) (LHV) \_\_\_\_\_
  - (2) Exhaust gas flow, lbs/hr \_\_\_\_\_
  - (3) Exhaust gas temperature, °F \_\_\_\_\_
  - (4) Exhaust gas specific heat, Btu/lb/°F \_\_\_\_\_
  - (5) Analysis of turbine exhaust gas, % vol.
    - (a) CO<sub>2</sub> \_\_\_\_\_
    - (b) N<sub>2</sub> \_\_\_\_\_
    - (c) H<sub>2</sub>O \_\_\_\_\_
    - (d) O<sub>2</sub> \_\_\_\_\_
  - (6) (Steam) (Water) injection lb/hr \_\_\_\_\_
- b. Peak net output rating of \_\_\_\_\_
- (1) Fuel Input, MMBtu/Hr (HHV) (LHV) \_\_\_\_\_  
Turbine-generator, kW \_\_\_\_\_
  - (2) Exhaust gas flow, lbs/hr \_\_\_\_\_



SECTION 18049 - GAS TURBINE DATA TO BE SUBMITTED WITH BID: continued

- (3) Exhaust gas temperature, °F \_\_\_\_\_
- (4) Exhaust gas specific heat, Btu/lb/°F \_\_\_\_\_
- (5) Analysis of turbine exhaust gas, % vol.
  - (a) CO<sub>2</sub> \_\_\_\_\_
  - (b) N<sub>2</sub> \_\_\_\_\_
  - (c) H<sub>2</sub>O \_\_\_\_\_
  - (d) O<sub>2</sub> \_\_\_\_\_
- (6) (Steam) (Water) injection lb/hr \_\_\_\_\_
- c. The net heat rate including all losses and auxiliary power uses will not exceed Btu/kWh (based on (HHV) (LHV) of fuel and net power to step-up transformer
  - (1) Peak load
    - Heat Rate, Btu/kWhr \_\_\_\_\_
    - Load, kW \_\_\_\_\_
  - (2) Baseload
    - Heat Rate, Btu/kWhr \_\_\_\_\_
    - Load, kW \_\_\_\_\_
  - (3) 3/4 load
    - Heat Rate, Btu/kWhr \_\_\_\_\_
    - Load, kW \_\_\_\_\_
  - (4) 1/2 load
    - Heat Rate, Btu/kWhr \_\_\_\_\_
    - Load, kW \_\_\_\_\_
- d. The spinning reserve net heat input will not exceed the following:
  - Heat input, Btu/hr (HHV) (LHV) \_\_\_\_\_
  - At minimum stable operating load of, kW \_\_\_\_\_
- e. The maximum generator capability at \_\_\_\_\_ volts, 90% power factor, when temp. rises are in accordance with ANSI standard C50 will be, kW: \_\_\_\_\_
- f. No<sub>x</sub> Emissions Control System:
  - (Steam pressure/temperature) \_\_\_\_\_ / \_\_\_\_\_

SECTION 18049 - GAS TURBINE DATA TO BE SUBMITTED WITH BID: continued

(Minimum quality of water required) \_\_\_\_\_  
Flow required at peak output, lb/hr \_\_\_\_\_  
Flow required at base output, lb/hr \_\_\_\_\_  
Flow required at 1/2 of baseload, lb/hr \_\_\_\_\_

g. Exhaust Emissions:

At Peak Rating:

CO, ppm by volume \_\_\_\_\_

NO<sub>x</sub>, ppm by volume \_\_\_\_\_

SO<sub>2</sub>, ppm by volume \_\_\_\_\_

based on \_\_\_% sulfur by weight in fuel \_\_\_\_\_

At Base Rating:

CO, ppm by volume \_\_\_\_\_

NO<sub>x</sub>, ppm by volume \_\_\_\_\_

SO<sub>2</sub>, ppm by volume \_\_\_\_\_

based on \_\_\_% sulfur by weight in fuel \_\_\_\_\_

h. Evaporative cooler water requirements:

Flow required at peak output, gpm \_\_\_\_\_

Flow required at base output, gpm \_\_\_\_\_

Flow required at 1/2 of base output, gpm \_\_\_\_\_

Minimum water quality required pH \_\_\_\_\_ to \_\_\_\_\_

Alkalinity, ppm max \_\_\_\_\_

Hardness, ppm max \_\_\_\_\_

2. Turbine Parts Life: Anticipated hours of operation at base rating before maintenance inspections are required based on \_\_\_ starts per year.

Combustion inspection, hrs \_\_\_\_\_

Hot gas inspection, hrs \_\_\_\_\_

Major inspection, hrs \_\_\_\_\_

3. Turbine Maintenance: Anticipated maintenance requirements at base rating based upon \_\_\_ starts per year.

a. Anticipated number of maintenance man-hours required for:

SECTION 18049 - GAS TURBINE DATA TO BE SUBMITTED WITH BID: continued

- Combustion inspection, man-hours \_\_\_\_\_
- Hot gas inspection, man-hours \_\_\_\_\_
- Major inspection, man-hours \_\_\_\_\_
- b. Anticipated average number of maintenance man-hours  
expended per year, man-hrs \_\_\_\_\_
- c. Anticipated unit maintenance costs, mils/kWh  
(based on \$25 per man-hour) \_\_\_\_\_
- 4. Firing Temperatures:
  - Firing temp. at peak rating, F \_\_\_\_\_
  - Firing temp. at base rating, F \_\_\_\_\_
  - Firing temp. quoted above is measured at (location on  
turbine) \_\_\_\_\_
- 5. Pressure Losses: The following pressure drops are  
in inches of water based on standard air with  
the unit operating under:
  - a. "Peak rating" conditions:
    - Total pressure loss to inlet flange at package, In. H<sub>2</sub>O \_\_\_\_\_
    - Total pressure loss from turbine exhaust flange, In. H<sub>2</sub>O \_\_\_\_\_
  - b. "Base rating" conditions:
    - Total pressure loss to inlet flange at package, In. H<sub>2</sub>O \_\_\_\_\_
    - Total pressure loss from turbine exhaust flange, In. H<sub>2</sub>O \_\_\_\_\_
- 6. Standby Requirements:
  - Standby energy consumption per hour \_\_\_\_°F, kW-hr \_\_\_\_\_
  - Max. standby ac power demand, kW \_\_\_\_\_
  - Max. demand on battery, amps \_\_\_\_ volts \_\_\_\_\_
- 7. Start-Up Time: Normal start/normal load
  - Cold standstill to ready for synchronizing, minutes \_\_\_\_\_
  - Synchronizing to baseload, minutes \_\_\_\_\_
  - Cooling air requirements, cfm
    - Base load \_\_\_\_\_
    - Peak load \_\_\_\_\_
  - Period of time cooling air is required after trip, minutes \_\_\_\_\_

SECTION 18049 - GAS TURBINE DATA TO BE SUBMITTED WITH BID: continued

1.03 DESCRIPTION OF EQUIPMENT:

The Bidder shall furnish equipment in accordance with the Specifications, and guarantees the performance of the following equipment to meet the requirements specified. The Bidder shall submit with the Bid the following equipment data:

A. Equipment Data:

1. Prime Mover and Power Train:

Combustion turbine, Mfgr. and type \_\_\_\_\_

Power turbine, Mfgr. and type \_\_\_\_\_

Type of burners \_\_\_\_\_

Gas turbine speed, rpm \_\_\_\_\_

Power turbine speed, rpm \_\_\_\_\_

Reduction gear manufacturer \_\_\_\_\_

Reduction gear capacity at 100,000-hr service rating, kW \_\_\_\_\_

Speed regulation full load to no load under  
normal conditions, percent \_\_\_\_\_

Increase in speed over full-load speed with full load  
suddenly thrown off, percent \_\_\_\_\_

2. Generator: (Data based \_\_\_ F cooling water and \_\_\_ ft. MSL,  
excepted as otherwise noted)

Manufacturer and type \_\_\_\_\_

Rated voltage, volts \_\_\_\_\_

Speed, rpm \_\_\_\_\_

Short-circuit ratio \_\_\_\_\_

Rated kVA and basis of rating \_\_\_\_\_

Exciter type \_\_\_\_\_

Field voltage - no load \_\_\_\_\_

Field voltage - peak capacity, 0.9-pf \_\_\_\_\_

Field current - peak capacity, 0.9-pf amps \_\_\_\_\_

Max. total temp. w/\_\_\_ F ambient at:

Base Capacity/and Peak Capacity, Kva \_\_\_\_\_ / \_\_\_\_\_

Rotor, degrees C (by resistance) \_\_\_\_\_ / \_\_\_\_\_

SECTION 18049 - GAS TURBINE DATA TO BE SUBMITTED WITH BID: continued

- Stator, degrees C (by detector) \_\_\_\_\_ / \_\_\_\_\_
- Calculated telephone interference factor,
- TIF of generator:
- Balanced: \_\_\_\_\_
- Residual: \_\_\_\_\_
- Lowest cooling air temp. permitted at windings during operation, F \_\_\_\_\_
- Percent reactance on the peak kVA base and at rated voltage of \_\_ kV:
- Direct axis synchronous at rated current,  $X_d$  \_\_\_\_\_
- Transient unsaturated at rated current,  $X'_{du}$  \_\_\_\_\_
- Transient saturated,  $X'_d$  \_\_\_\_\_
- Subtransient (at rated voltage)  $X''_d$  \_\_\_\_\_
- Zero sequence (at rated voltage)  $X_0$  \_\_\_\_\_
- Negative sequence (at rated voltage)  $X_2$  \_\_\_\_\_
- Synchronous impedance,  $Z_d$  \_\_\_\_\_
- Three-phase capacitance to ground, mfd \_\_\_\_\_
3. Metal-Clad Switchgear:
- Manufacturer of switchgear structure \_\_\_\_\_
- Manufacturer and type of circuit breakers \_\_\_\_\_
- Manufacturer and type of switchgear relays \_\_\_\_\_
4. Generator Accessory Equipment:
- Manufacturer and type of arresters \_\_\_\_\_
- Manufacturer and type of capacitors \_\_\_\_\_
- Manufacturer and type of main breaker \_\_\_\_\_
- Manufacturer of neutral transformer and resistor \_\_\_\_\_
- Telephone influence factor suppression accessories, if required to meet specified TIF; description \_\_\_\_\_
5. Auxiliary Power Apparatus:
- Manufacturer and type of motor starters \_\_\_\_\_
- Manufacturer of transformers \_\_\_\_\_
- Station auxiliary transformer kVA/volt rating \_\_\_\_\_ / \_\_\_\_\_
- Starting motor transformer kVA/volt rating \_\_\_\_\_ / \_\_\_\_\_

SECTION 18049 - GAS TURBINE DATA TO BE SUBMITTED WITH BID: continued

- 6. Silencing Equipment:
  - Manufacturer \_\_\_\_\_
  - Inlet, ft in length \_\_\_\_\_
  - Exhaust, ft in length \_\_\_\_\_
  - Other, describe \_\_\_\_\_
  - \_\_\_\_\_
  - \_\_\_\_\_
  
- 7. Exhaust Connection Dimensions \_\_\_\_\_
  
- 8. Intake Evaporative Air Cooler
  - Manufacturer \_\_\_\_\_
  - Face area \_\_\_\_\_
  
- 9. Inlet Air Filter:
  - Number of stages \_\_\_\_\_
  - Pressure drop across filters \_\_\_\_\_
  - Face area \_\_\_\_\_
  
- 10. Generator Air Filter:
  - Manufacturer and Model Number \_\_\_\_\_
  - Face area \_\_\_\_\_
  
- 11. Starting System:
  - Type \_\_\_\_\_
  - Manufacturer \_\_\_\_\_
  - Horsepower and Voltage \_\_\_\_\_
  
- 12. Lubricating Oil and Special Fluids:
  - Type and quantity for combustion turbine \_\_\_\_\_
  - Type and quantity for power turbine \_\_\_\_\_
  - Type and quantity for generator \_\_\_\_\_
  - Special fluids required, list \_\_\_\_\_
  - \_\_\_\_\_
  
- 13. Other:
  - Ac standby power connected load, kW \_\_\_\_\_
  - Dc standby power connected load, kW \_\_\_\_\_
  - Describe other major equipment \_\_\_\_\_
  - \_\_\_\_\_

SECTION 18049 - GAS TURBINE DATA TO BE SUBMITTED WITH BID: continued

---

14. Major Component Weights: (in pounds)

Combustion Turbine Unit \_\_\_\_\_

Power Turbine Unit \_\_\_\_\_

Generator and Exciter \_\_\_\_\_

Other Major Equipment \_\_\_\_\_

Describe \_\_\_\_\_

---

Heaviest piece to be handled during erection (identify piece) \_\_\_\_\_

Heaviest piece to be handled after erection (identify piece) \_\_\_\_\_

Heaviest piece to be handled for routine inspection of  
hot gas path \_\_\_\_\_

Compressor rotor \_\_\_\_\_

Power turbine rotor \_\_\_\_\_

Generator rotor \_\_\_\_\_

PART 2 - PRODUCTS - Not Applicable.

PART 3 - EXECUTION - Not Applicable.

END OF SECTION 18049

SECTION 18099 - HRSG DATA TO BE SUBMITTED WITH BID

PART 1 - GENERAL

1.01 PERFORMANCE GUARANTEES:

A. The Bidder guarantees the performance of the heat recovery steam generator to be as stated below when the unit is operated using combustion turbine exhaust under the conditions specified in SECTION 2.

1. Outlet steam flow, lb/hr \_\_\_\_\_
2. Superheater outlet pressure, psig \_\_\_\_\_
3. Superheater outlet temperature, °F \_\_\_\_\_
4. Steam Purity:
  - a. Maximum total solids in steam entering superheater, ppm \_\_\_\_\_
  - b. Maximum silica in steam entering superheater, ppm \_\_\_\_\_
5. Duct burner nitrogen oxides production, lbs/MMBtu \_\_\_\_\_
6. Duct burner carbon monoxides production, lbs/MMBtu \_\_\_\_\_
7. Duct burner particulate production, lbs/MMBtu \_\_\_\_\_
8. Duct burner VOC production, lbs/MMBtu \_\_\_\_\_
9. Maximum combustion turbine backpressure, inch WG \_\_\_\_\_
10. Stack exit gas temperature, °F \_\_\_\_\_
11. Feedwater inlet pressure required, psig \_\_\_\_\_
12. Supplemental firing fuel, MMBtu/hr \_\_\_\_\_
13. Fan power usage, kW \_\_\_\_\_

B. The Bidder guarantees the performance of the heat recovery steam generator to be as stated below when the unit is operated with fresh air firing under the conditions specified in SECTION 2.

1. Outlet steam flow, lb/hr \_\_\_\_\_
2. Steam outlet pressure, psig \_\_\_\_\_
3. Superheater outlet temperature, °F \_\_\_\_\_
4. Steam Purity:
  - a. Maximum total solids in steam entering superheater, ppm \_\_\_\_\_



SECTION 18099 - HRSG DATA TO BE SUBMITTED WITH BID: continued

- b. Maximum silica in steam entering superheater, ppm \_\_\_\_\_
- 5. Gas side pressure drop, inch WG \_\_\_\_\_
- 6. Maximum nitrogen oxides emissions, lbs/MMBtu \_\_\_\_\_
- 7. Maximum carbon monoxides emissions, lbs/MMBtu \_\_\_\_\_
- 8. Maximum particulate emissions, ppm \_\_\_\_\_
- 9. Maximum VOC emissions, lbs/MMBtu \_\_\_\_\_
- 10. Stack exit gas temperature, °F \_\_\_\_\_
- 11. Feedwater inlet pressure required, psig \_\_\_\_\_
- 12. Supplemental firing fuel, MMBtu/hr \_\_\_\_\_
- 13. Fan power usage, kW \_\_\_\_\_
- 14. Time to regain full steam load after combustion turbine trip, seconds \_\_\_\_\_

1.02 EXPECTED PERFORMANCE DATA:

- A. The Bidder shall submit the following expected performance data by filling in the blanks provided:

<u>Operating Mode</u>	<u>CT Exhaust w/o Supp. Fire</u>	<u>CT Exhaust w/Supp. Fire</u>	<u>Fresh Air Max. Load</u>	<u>Fresh Air 80% Load</u>
Steam Flow at Superheater Outlet thousand lbs/hr				
Superheater Outlet Pressure, psig				
1. Quantities				
a. Combustion air flow, lb/hr	_____	_____	_____	_____
b. Supplemental firing fuel, lb/hr	_____	_____	_____	_____
2. Pressure Drops				
a. Drum to superheater outlet, psi	_____	_____	_____	_____

SECTION 18099 - HRSG DATA TO BE SUBMITTED WITH BID: continued

b.	Economizer inlet to drum, psi	_____	_____	_____	_____
3.	Temperatures, °F				
a.	Superheater outlet steam	_____	_____	_____	_____
b.	Steam after desuperheater	_____	_____	_____	_____
c.	Steam before desuperheater	_____	_____	_____	_____
d.	Drum outlet steam				
e.	Economizer outlet water	_____	_____	_____	_____
f.	Air/Flue Gas	_____	_____	_____	_____
(1)	Entering duct burner	_____	_____	_____	_____
(2)	Leaving duct burner	_____	_____	_____	_____
(3)	Entering superheater	_____	_____	_____	_____
(4)	Entering boiler	_____	_____	_____	_____
(5)	Entering economizer	_____	_____	_____	_____
(6)	Entering ID fan	_____	_____	_____	_____
(7)	Entering stack	_____	_____	_____	_____
4.	Air/Flue Gas Resistance, In WG	_____	_____	_____	_____
a.	Inlet damper	_____	_____	_____	_____
b.	Transition duct	_____	_____	_____	_____
c.	Duct burner	_____	_____	_____	_____
d.	Superheater	_____	_____	_____	_____
e.	Boiler	_____	_____	_____	_____
f.	Economizer	_____	_____	_____	_____
g.	Ductwork, economizer to fan	_____	_____	_____	_____

SECTION 18099 - HRSG DATA TO BE SUBMITTED WITH BID: continued

h.	Ductwork, fan to stack	_____	_____	_____	_____
i.	Other	_____	_____	_____	_____
j.	Combustion turbine Backpressure	_____	_____	_____	_____
k.	Total or Delta on Fan	_____	_____	_____	_____
5.	Fan Test Block Data	Design Point	Test Block		
a.	Inlet temp, °F	_____	_____		
b.	Inlet flow, lb/hr	_____	_____		
c.	Inlet flow, cfm	_____	_____		
d.	Static pressure, in WG	_____	_____		
e.	Fan speed, rpm	_____	_____		
f.	BHP	_____	_____		

1.03 DESCRIPTION OF EQUIPMENT:

The Bidder shall submit with the Bid the following equipment data:

- A. Model designation: \_\_\_\_\_
- B. Design Pressures:
  - 1. Superheater, psi \_\_\_\_\_
  - 2. Drum, psi \_\_\_\_\_
  - 3. Boiler, psi \_\_\_\_\_
  - 4. Economizer, psi \_\_\_\_\_
  - 5. Ductwork and Casing,  
In WG (Vacuum/Pressure) \_\_\_\_\_ / \_\_\_\_\_
- C. Total Effective Heating Surface, Sq. Ft.
  - 1. Superheater \_\_\_\_\_
  - 2. Boiler \_\_\_\_\_
  - 3. Economizer \_\_\_\_\_
- D. Size and Material of Tubes:
  - 1. Superheater \_\_\_\_\_
  - 2. Boiler \_\_\_\_\_

SECTION 18099 - HRSG DATA TO BE SUBMITTED WITH BID: continued

- 3. Economizer \_\_\_\_\_
- E. Description and Material of Fins:
  - 1. Superheater \_\_\_\_\_
  - 2. Boiler \_\_\_\_\_
  - 3. Economizer \_\_\_\_\_
- F. Casing and Ductwork:
  - 1. Casing material \_\_\_\_\_
  - 2. Thickness \_\_\_\_\_
  - 3. Duct material \_\_\_\_\_
  - 4. Thickness \_\_\_\_\_
- G. Duct Burner:
  - 1. Manufacturer \_\_\_\_\_
  - 2. Type or model \_\_\_\_\_
  - 3. Maximum Capacity, MMBtu/hr \_\_\_\_\_
- H. Weights, Lbs:
  - 1. Steam generator \_\_\_\_\_
  - 2. Platforms, stairs, support steel \_\_\_\_\_
  - 3. Total weight of complete unit \_\_\_\_\_
    - a. Dry \_\_\_\_\_
    - b. During normal operation \_\_\_\_\_
    - c. During hydrostatic test \_\_\_\_\_
- I. Steam Drum:
  - 1. Length \_\_\_\_\_
  - 2. Diameter \_\_\_\_\_
  - 3. Thickness \_\_\_\_\_
  - 4. Material \_\_\_\_\_
- J. Connection Sizes:
  - 1. Feedwater inlet, inches \_\_\_\_\_
  - 2. Steam outlet, inches \_\_\_\_\_
- K. Safety Valves:
  - 1. Number \_\_\_\_\_
  - 2. Model \_\_\_\_\_
  - 3. Size \_\_\_\_\_

SECTION 18099 - HRSG DATA TO BE SUBMITTED WITH BID: continued

L. Stack Dimensions:

1. Diameter \_\_\_\_\_
2. Height \_\_\_\_\_
3. Material \_\_\_\_\_
4. Thickness \_\_\_\_\_

M. In addition to the data requested above, the Bidder shall submit the following:

1. General arrangement drawing showing duct and equipment layout. Also to be included are maximum loads and locations of duct supports, if required.
2. Preliminary foundation outline and loads of all items.
3. List of all instrumentation and boiler trim, including number of items, size, manufacturer, and model number.
4. Preliminary control panel outline drawing and panel front arrangement drawing.
5. Information concerning special requirements for curing of refractory and insulation which impact turbine operation (i.e., temperature limits and times).
6. Description of type of fins (segmented or continuous, etc).
7. List of previously completed projects.

PART 2 - PRODUCTS - NOT APPLICABLE

PART 3 - EXECUTION - NOT APPLICABLE

END OF SECTION 18099

SECTION 18149 - DATA TO BE SUBMITTED WITH BID - STEAM TURBINE

PART 1 - GENERAL

1.01 PERFORMANCE GUARANTEES:

A. The Bidder guarantees the characteristics of the turbine generator unit to be at least as stated below when operated under the conditions specified.

1. Guaranteed capability at rated throttle and reheat conditions with \_\_\_\_\_-inch mercury absolute backpressure, zero percent makeup, full feedwater heating, rated hydrogen pressure and 0.9 power factor: \_\_\_\_\_ kW.
2. Guaranteed throttle flow at rated throttle and reheat conditions with \_\_\_\_\_ -inch mercury absolute backpressure, 0% makeup, full feedwater heating, rated hydrogen pressure, and 0.9 power factor \_\_\_\_\_ lb/hr.
3. Turbine (gross) (net) heat rates at rated throttle and reheat conditions with \_\_\_\_\_-inch mercury absolute backpressure, 0% makeup, full feedwater heating, rated hydrogen pressure, and 0.9 power factor:

<u>Percent of Guaranteed Capability</u>	<u>Turbine (Gross)(Net) Heat Rate, Btu/kWh</u>
100	_____
80	_____
60	_____
40	_____
20	_____

4. Generator capability at 0.9 power factor:

<u>Hydrogen Pressure</u>	<u>Generator Capability,</u>
Full psig	_____
Intermediate psig	_____
Minimum psig	_____

5. Output voltage: \_\_\_\_\_ volts.
6. Generator efficiency at rated load: \_\_\_\_\_%.

SECTION 18149 - DATA TO BE SUBMITTED WITH BID - STEAM TURBINE: continued

7. Temperature rise of the following:
  - a. Generator Stator: \_\_\_\_\_ °C.
  - b. Generator Rotor: \_\_\_\_\_ °C.
  - c. Generator Exciter - Stator: \_\_\_\_\_ °C.  
- Rotor: \_\_\_\_\_ °C.
8. Maximum hydrogen loss at full frame pressure and at rated kVA operation: \_\_\_\_\_ standard ft<sup>3</sup>/day.
9. Full frame hydrogen pressure: \_\_\_\_\_ psig.

1.02 EXPECTED PERFORMANCE DATA:

- A. The Bidder shall submit the following expected performance data by filling in the blanks provided:
  1. Maximum expected throttle flow, capability and heat rate when operating at valves wide open, 5% overpressure, 1000°F High Pressure, 1000°F Hot Reheat, \_\_\_\_\_-inch mercury absolute backpressure, zero percent makeup, full feedwater heating, rated hydrogen pressure, and 0.9 power factor:
    - a. Throttle flow: \_\_\_\_\_ lb/hr
    - b. Capability: \_\_\_\_\_ kW
    - c. (Gross) (Net) heat rate: \_\_\_\_\_ Btu/kWh
    - d. Reheat steam flow: \_\_\_\_\_ lb/hr
    - e. Condenser steam flow: \_\_\_\_\_ lb/hr
  2. Maximum expected throttle flow, capability and heat rate when operating at valves wide open, rated pressure, 1000°F High Pressure, 1000°F Hot Reheat, \_\_\_\_\_-inch mercury absolute backpressure, 0% makeup, full feedwater heating, rated hydrogen pressure, and 0.9 power factor:
    - a. Throttle flow: \_\_\_\_\_ lb/hr
    - b. Capability: \_\_\_\_\_ kW
    - c. Reheat steam flow: \_\_\_\_\_ lb/hr
    - d. Condenser steam flow: \_\_\_\_\_ lb/hr
  3. Minimum safe continuous load
    - a. at \_\_\_\_\_ inch Hg absolute: \_\_\_\_\_ kW
  4. Minimum absolute backpressure  
for safe continuous operation of the unit:

SECTION 18149 - DATA TO BE SUBMITTED WITH BID - STEAM TURBINE: continued

- a. At full load: \_\_\_\_\_ in. Hg
- b. At minimum continuous load: \_\_\_\_\_ in. Hg
- 5. Minimum time required for applying full load on the unit:
  - a. After 8-hour shutdown on turning gear \_\_\_\_\_ minutes
  - b. From cold start \_\_\_\_\_ minutes
- 6. Maximum allowable exhaust hood temperature:
  - a. During start-up: \_\_\_\_\_ °F for \_\_\_\_\_ minutes. \_\_\_\_\_ °F.
  - b. During continuous operation \_\_\_\_\_ °F.
- 7. No load throttle flow at rated conditions and \_\_\_\_\_-inch mercury absolute backpressure: \_\_\_\_\_ lb/hr
- 8. Generator efficiency with full frame hydrogen pressure:
  - Maximum expected load \_\_\_\_\_ %
  - Guaranteed load \_\_\_\_\_ %
    - a. 80% guaranteed load \_\_\_\_\_ %
    - b. 60% guaranteed load \_\_\_\_\_ %
    - c. 40% guaranteed load \_\_\_\_\_ %
    - d. 20% guaranteed load \_\_\_\_\_ %
- 9. Generator capability with one hydrogen cooler out of service: \_\_\_\_\_ kVA
- 10. Generator field current at rated load: \_\_\_\_\_ amps
- 11. Rated load field voltage: \_\_\_\_\_ volts
- 12. Excitation system ceiling voltage (per unit of rated field voltage) \_\_\_\_\_ p.u.
- 13. Excitation system voltage response time: \_\_\_\_\_ volts/sec
- 14. Percent reactances on a base of \_\_\_\_\_ kVA (to be maximum for generator) and at \_\_\_\_\_ kV



SECTION 18149 - DATA TO BE SUBMITTED WITH BID - STEAM TURBINE: continued

- a. Direct axis synchronous at rated current  $X_d$  \_\_\_\_\_
- b. Transient unsaturated at rated current  $X'_{du}$  \_\_\_\_\_
- c. Transient saturated,  $X'_d$  \_\_\_\_\_
- d. Subtransient (at rated voltage)  $X''_d$  \_\_\_\_\_
- e. Zero sequence (at rated current)  $X_0$  \_\_\_\_\_
- f. Negative sequence (at rated voltage)  $X_2$  \_\_\_\_\_
- g. Synchronous impedance,  $Z_d$  \_\_\_\_\_
- 15. Time constants:
  - a. Open circuit,  $T'_{do}$  \_\_\_\_\_
  - b. Armature,  $T_a$  \_\_\_\_\_
  - c. Transient,  $T_d$  \_\_\_\_\_
  - d. Subtransient,  $T''_d$  \_\_\_\_\_
- 16. Pull-out torque at rated voltage and kVA with infinite bus:
  - a. At 0.85 pf \_\_\_\_\_ kW
  - b. At 0.90 pf \_\_\_\_\_ kW
  - c. At 1.0 pf \_\_\_\_\_ kW
- 17. Winding capacitance, all three phases combined to ground: \_\_\_\_\_ mfd
- 18. Telephone interference factors, calculated:
  - a. Balanced: \_\_\_\_\_
  - b. Residual: \_\_\_\_\_
- 19. Short circuit ratio at rated kVA and maximum frame hydrogen pressure, calculated: \_\_\_\_\_
- 20. Flywheel effect,  $WR^2$ 
  - a. For turbine: \_\_\_\_\_ in lb-ft<sup>2</sup>

SECTION 18149 - DATA TO BE SUBMITTED WITH BID - STEAM TURBINE: continued

- b. For generator and exciter: \_\_\_\_\_ in lb-ft<sup>2</sup>
21. Saturation factor: \_\_\_\_\_
22. Regulation at: \_\_\_\_\_ kVA  
(to be maximum for generator)  
and 0.9 power factor: \_\_\_\_\_ %
23. Rated armature current: \_\_\_\_\_ amps
24. Field characteristics at 125°C: Amperes      Volts
- a. Exciter rating: \_\_\_\_\_
- b. No load, at rated generator terminal voltage at 20°C \_\_\_\_\_
- c. Rated armature current, zero generator-terminal voltage \_\_\_\_\_
- d. With machine carrying rated kVA, with rated terminal voltage and 0.9 power factor, at:
- (1) Full frame hydrogen pressure: \_\_\_\_\_
- (2) Intermediate hydrogen pressure: \_\_\_\_\_ psig \_\_\_\_\_
- e. Minimum field current required to hold generator in step under steady state loading at guaranteed capability. \_\_\_\_\_
- f. Generator load and power factor with machine carrying rated kVA, with rated terminal voltage, full frame hydrogen pressure and with leading power factor (maximum pull out on infinite bus) \_\_\_\_\_ kW      \_\_\_\_\_ pf
- g. Field conductor material: \_\_\_\_\_
- h. Field resistance, ohms at 20°C: \_\_\_\_\_
- i. Field temperature coefficient of \_\_\_\_\_

SECTION 18149 - DATA TO BE SUBMITTED WITH BID - STEAM TURBINE: continued

- resistance, ohms/ohm/°C \_\_\_\_\_  
from 0°C: \_\_\_\_\_
- j. Field discharge resistor rating  
at 20°C, ohms: \_\_\_\_\_
25. Gas volume within stator housing  
with rotor in place: \_\_\_\_\_ ft<sup>3</sup>
26. Hydrogen temperature at full rated  
kVA, 0.90 power factor, and  
95°F inlet cooling water:
- a. Entering Hydrogen Cooler  
(hot Hydrogen) \_\_\_\_\_ °C
- b. Leaving Hydrogen Cooler  
(cold Hydrogen) \_\_\_\_\_ °C

1.03 PHYSICAL DATA:

- A. Bidder shall submit his standard proposition outline drawing of the turbine generator unit which shall show at least the following information:
1. Weights of major components (including heaviest single lift required for placement and/or maintenance).
  2. Dimensions (length, width, height) adequate for layout and preliminary foundation design including turbine room hook height required for service and maintenance.
  3. Number and size of Owner's connections.
  4. Excitation switchgear dimensions, if applicable.
  5. Neutral enclosure dimensions.
  6. Last stage blade length.
  7. Clearance diagram for generator rotor removal, straight and skewed.
  8. Clearance diagram for hydrogen cooler removal.

1.04 MISCELLANEOUS DATA:

- A. Bidder shall submit the following miscellaneous data by filling in the blanks provided:
1. Turning gear data:
    - a. Speed of rotor: \_\_\_\_\_ rpm
    - b. Motor size: \_\_\_\_\_ hp

SECTION 18149 - DATA TO BE SUBMITTED WITH BID - STEAM TURBINE: continued

2. Cooler data with cooling water inlet temperature listed:

a. Cooling water flow expected:

- (1) Lube oil coolers (\_\_\_\_°F) \_\_\_\_\_ gpm
- (2) Electrohydraulic system  
coolers (\_\_\_\_°F) \_\_\_\_\_ gpm
- (3) Gland steam condenser  
(min \_\_\_\_°F) \_\_\_\_\_ gpm
- (4) Hydrogen coolers  
(\_\_\_\_°F) \_\_\_\_\_ gpm
- (5) Seal oil coolers  
(\_\_\_\_°F) \_\_\_\_\_ gpm
- (6) Exciter coolers (\_\_\_\_°F) \_\_\_\_\_ gpm
- (7) Conductor cooling system  
coolers (\_\_\_\_°F) \_\_\_\_\_ gpm

b. Cooling water pressure drop  
expected:

- (1) Lube oil coolers \_\_\_\_\_ psi
- (2) Electrohydraulic system  
coolers \_\_\_\_\_ psi
- (3) Gland steam condenser \_\_\_\_\_ psi
- (4) Hydrogen coolers \_\_\_\_\_ psi
- (5) Seal oil coolers \_\_\_\_\_ psi
- (6) Exciter coolers \_\_\_\_\_ psi
- (7) Conductor cooling system  
coolers \_\_\_\_\_ psi

c. Tube Diameter (I.D.)

- (1) Lube oil coolers \_\_\_\_\_ in
- (2) Electrohydraulic system  
coolers \_\_\_\_\_ in
- (3) Gland steam condenser \_\_\_\_\_ in
- (4) Hydrogen coolers \_\_\_\_\_
- (5) Seal oil coolers \_\_\_\_\_ in
- (6) Exciter coolers \_\_\_\_\_ in

SECTION 18149 - DATA TO BE SUBMITTED WITH BID - STEAM TURBINE: continued

- (7) Conductor cooling system  
coolers \_\_\_\_\_ in
3. Gland steam flow:  
a. Maximum \_\_\_\_\_ lb/hr  
b. Minimum \_\_\_\_\_ lb/hr  
Exhaust annulus area: \_\_\_\_\_ sq ft
4. Lubricating oil circulation rate  
through coolers: \_\_\_\_\_ gpm
5. Total volume of lube oil required: \_\_\_\_\_ gal
6. Total volume of governor fluid required: \_\_\_\_\_ gal

PART 2 - PRODUCTS - Not Applicable.

PART 3 - EXECUTION - Not Applicable.

END OF SECTION 18149