

STATEMENT OF WORK AND SPECIFICATIONS

Issued for RFP

Revision 1

1-25-08

**CURRENT CREEK POWER PROJECT
BLOCK 2**

PACIFICORP

CURRANT CREEK POWER PROJECT – BLOCK 2

TABLE OF CONTENTS

SECTION 1.0	1-1
INTRODUCTION	1-1
1.1 GENERAL PLANT DESCRIPTION	1-1
1.1.1 Specifications.....	1-2
1.1.1.1 General.....	1-2
1.2 OVERALL SCOPE DESCRIPTION.....	1-3
1.2.1 General Scope	1-3
1.2.2 Work by Others	1-5
1.2.3 Terminal Points.....	1-5
1.2.3.1 345 kV Switchyard.....	1-5
1.2.3.2 Natural Gas	1-6
1.2.3.3 Water Supply.....	1-6
1.2.3.4 Process Waste Water Discharge.....	1-7
1.2.3.5 Telephone and Data Communications	1-7
1.2.4 Owner Furnished Equipment and Systems	1-8
1.2.5 Noise Levels	1-8
1.2.5.1 Equipment Noise Requirements.....	1-8
1.2.5.2 Indoor Noise Limits.....	1-9
1.2.5.3 Far Field Noise Guarantees	1-9
1.2.6 Mechanical Scope.....	1-9
1.2.7 Electrical Scope	1-11
1.2.8 Instrumentation and Control Scope	1-12
1.2.9 Civil Scope	1-12
1.2.10 Structural and Architectural Scope	1-13
1.2.11 Construction Facilities and Services.....	1-13
1.2.11.1 General.....	1-13
1.2.11.2 Coordination.....	1-14
1.2.11.3 Safety	1-15
1.2.11.4 Security	1-16
1.2.11.5 Fire Protection	1-16
1.2.11.6 Cleanliness.....	1-17
1.2.11.7 Signs and Barricades	1-18

1.2.11.8	Dust Control	1-18
1.2.11.9	Open Burning	1-18
1.2.11.10	Cooperation with Other Contractors.....	1-18
1.2.11.11	Energized Facilities.....	1-19
1.2.11.12	Reference Points	1-19
1.2.11.13	Dangerous Materials.....	1-19
1.2.11.14	Waste Disposal.....	1-19
1.2.11.15	Hazardous Material Management.....	1-20
1.2.11.16	Adjoining Utilities.....	1-20
1.2.12	Production Inputs	1-21
1.2.13	Operating Consumables	1-21
1.3	PLANT OPERATING PROFILE	1-22
1.3.1	Plant Load Definition.....	1-22
1.3.2	Plant Operating Profile.....	1-23
1.3.3	Plant Operating Philosophy	1-23
1.3.4	Plant Reliability	1-23
1.3.5	Plant Performance	1-24
SECTION 2.0	2-1
2.1	GEOTECHNICAL CONDITIONS	2-2
2.2	SITE SECURITY	2-2
2.3	SITE ACCESS.....	2-2
2.4	SITE ENVIRONMENT	2-3
SECTION 3.0	3-1
SECTION 4.0	1
4.1	GENERAL REQUIREMENTS	1
4.1.1	Architectural Design.....	4-3
4.1.2	Civil / Structural Design.....	4-4
4.1.3	Mechanical Design.....	4-4
4.1.4	Electrical Design	4-6
4.1.5	Instrumentation and Controls Design	4-7
4.2	DESIGN REVIEWS	4-8
4.3	DRAWING AND SPECIFICATION REQUIREMENTS.....	4-8
4.3.1	Drawing and Specification Schedule	4-8

4.3.2	Drawing and Specification Submittals	4-9
4.3.3	Plant Manual and Instruction Books	4-16
4.3.3.1	Plant Manual	4-16
4.3.3.2	Manufacturer's Instruction Books	4-17
4.3.4	System Startup & Commissioning Test Procedures and Reports	4-18
4.3.5	Project Administration Manual	4-19
4.3.6	Critical Path Schedule.....	4-19
4.3.7	Project Status Reports	4-19
4.3.8	Coordination Meetings	4-19
4.3.9	Contractor Acquired Permits.....	4-20
4.4	QUALITY ASSURANCE.....	4-20
SECTION 5.0.....		5-1
5.1	GENERAL REQUIREMENTS	5-1
5.1.1	General Sizing Criteria.....	5-1
5.1.2	Piping	5-2
5.1.3	General Arrangements.....	5-4
5.1.4	Platforms	5-4
5.1.5	Accessways and Clearances.....	5-6
5.1.5.1	Horizontal Clearances (Minimum):	5-6
5.1.5.2	Vertical Clearances (Minimum):	5-7
5.2	MECHANICAL SYSTEMS AND EQUIPMENT	5-7
5.2.1	General	5-7
5.2.2	Pumps - General.....	5-8
5.2.3	Tanks and Vessels - General	5-9
5.2.4	Heat Exchangers - General	5-11
5.2.5	Gas Turbine Generator (GTG) System.....	5-11
5.2.5.1	Gas Turbine and Accessories	5-15
5.2.5.2	Prime Mover	5-16
5.2.5.3	Governing System.....	5-17
5.2.5.4	Fuel System	5-17
5.2.5.5	Water/Steam Injection System	5-18
5.2.5.6	Lubricating Oil System.....	5-19
5.2.5.7	Starting System	5-19
5.2.5.8	Special Tools.....	5-20

5.2.5.9	Inlet Air Filter	5-20
5.2.5.10	Exhaust Connection	5-21
5.2.5.11	Bypass Stack.....	5-21
5.2.5.12	Water Wash System.....	5-21
5.2.5.13	Insulation	5-22
5.2.5.14	Sound Control Equipment	5-22
5.2.5.15	Maintenance Access	5-22
5.2.5.16	Fire Protection System	5-22
5.2.5.17	Vibration Monitoring Equipment	5-23
5.2.5.18	Painting	5-23
5.2.5.19	Gas Turbine – Electrical and Controls.....	5-24
5.2.6	Steam Turbine (STG).....	5-30
5.2.6.1	General.....	5-34
5.2.6.2	Turbine	5-36
5.2.6.3	Electrohydraulic Control System	5-42
5.2.6.4	Turbine Control System.....	5-43
5.2.6.5	Turbine Rotor Stress Monitoring.....	5-45
5.2.6.6	Turbine Supervisory System	5-45
5.2.6.7	Lubrication System.....	5-46
5.2.6.8	Gland Steam System	5-48
5.2.7	Combustion and Steam Turbine Electrical Generator	5-49
5.2.7.1	General:.....	5-49
5.2.7.2	Applicable Codes and Standards	5-49
5.2.7.3	Quality Assurance	5-51
5.2.7.4	Factory Tests.....	5-51
5.2.7.5	Submittals.....	5-52
5.2.7.6	Products	5-53
5.2.8	Heat Recovery Steam Generator (HRSG) System	5-67
5.2.8.1	General.....	5-69
5.2.8.2	Pressure Parts.....	5-70
5.2.8.3	Boiler	5-71
5.2.8.4	Drums.....	5-75
5.2.8.5	Piping	5-76
5.2.8.6	Ductwork, Casings and Insulation	5-81
5.2.8.7	Insulation	5-82

5.2.8.8	Access.....	5-82
5.2.8.9	Duct Burners	5-83
5.2.8.10	Selective Catalytic Reduction System.....	5-85
5.2.8.11	Ammonia Injection Skid.....	5-87
5.2.8.12	CO Catalyst.....	5-87
5.2.8.13	HRSG Erection.....	5-88
5.2.8.14	Ammonia Equipment.....	5-101
5.2.9	Steam Systems.....	5-101
5.2.9.1	HP (Main) Steam System.....	5-103
5.2.9.2	Reheat Steam System	5-103
5.2.9.3	LP Steam System.....	5-104
5.2.9.4	Auxiliary Steam System.....	5-104
5.2.10	Condensate System.....	5-105
5.2.11	Boiler Feedwater System.....	5-106
5.2.12	Raw Water Supply System	5-107
5.2.13	Service Water System	5-108
5.2.14	Raw Water Treatment System.....	5-108
5.2.15	Demineralized Water System	5-109
5.2.16	HRSG Blowdown Recycle.....	5-112
5.2.17	Air Cooled Condensing System.....	5-113
5.2.17.1	Design Parameters.....	5-115
5.2.17.2	Air Cooled Condenser (ACC)	5-116
5.2.17.3	Steam Duct:.....	5-121
5.2.17.4	Condensate Receiver Tank	5-122
5.2.17.5	Piping and Valves:.....	5-123
5.2.17.6	Cold Weather Operation.....	5-123
5.2.17.7	Steam By-pass System:	5-124
5.2.17.8	Air Removal Equipment:.....	5-124
5.2.18	Chemical Injection Systems.....	5-125
5.2.18.1	Boiler Water Chemical Systems	5-125
5.2.19	Powdered Resin Condensate Polisher	5-126
5.2.20	Closed Cooling Water System.....	5-135
5.2.21	Fuel Gas System	5-136
5.2.22	Compressed Air System	5-139
5.2.23	Sampling and Analysis System	5-141

5.2.24	Fire Protection System.....	5-144
5.2.25	Potable Water System	5-149
5.2.26	Process Bulk Gas Storage and Distribution System	5-149
5.2.27	Wastewater Collection and Transfer System	5-151
5.2.27.1	Sanitary Wastewater	5-151
5.2.27.2	Oily Wastewater	5-151
5.2.27.3	GTG Water Wash.....	5-152
5.2.27.4	Process Wastewater	5-152
5.2.28	Heating, Ventilating, and Air Conditioning System	5-152
5.3	PLANT PIPING REQUIREMENTS.....	5-158
5.3.1	General Requirements.....	5-158
5.3.2	Piping Classes	5-161
5.3.3	Line List.....	5-165
5.3.4	Clearances.....	5-165
5.3.5	Piping Stress Analysis	5-165
5.3.6	Pipe Bending.....	5-167
5.3.7	Pipe Sleeves	5-167
5.3.8	Dissimilar Metal Joints	5-167
5.3.9	Equipment for Plant Start-up	5-167
5.3.10	Sewer and Underground Piping.....	5-168
5.3.11	Vents and Drains and Manholes.....	5-168
5.3.12	Root Valves.....	5-168
5.3.13	Root Connections	5-169
5.3.14	Fabrication Requirements.....	5-169
5.3.15	Shop Cleaning	5-170
5.3.16	Inspection.....	5-170
5.3.17	Protection for Shipment and Construction.....	5-170
5.3.18	Welding	5-171
5.3.19	Field Installation	5-171
5.3.20	Pipe Supports, Guides, Restraints, and Anchors	5-172
5.3.20.1	General Requirements	5-172
5.3.20.2	Attachments to Piping	5-173
5.3.20.3	Attachments to Structure.....	5-174
5.3.20.4	Spacing	5-175
5.3.20.5	Pipe Support Identification.....	5-175

5.3.20.6	Anchors, Restraints, and Sliding Supports	5-175
5.3.20.7	Hanger Rods	5-176
5.3.20.8	Variable Spring Hangers	5-176
5.3.20.9	Adjustment and Locking Devices	5-177
5.3.20.10	Inspection	5-177
5.3.21	Painting	5-178
5.3.22	Testing	5-178
5.4	VALVES	5-179
5.4.1	General Requirements.....	5-179
5.4.2	Valve Materials	5-180
5.4.3	Valve Shop Painting.....	5-180
5.4.4	Lubricant Materials.....	5-180
5.4.5	Design Requirements	5-180
5.4.6	Valve Operators	5-182
5.5	INSULATION AND JACKETING	5-183
5.5.1	General Requirements.....	5-183
5.5.1.1	Insulation.....	5-183
5.5.1.2	Jacketing	5-186
SECTION 6.0	6-1
6.1	GENERAL REQUIREMENTS	6-1
6.2	SITE PREPARATION AND MAINTENANCE	6-2
6.2.1	Site Preparation	6-2
6.2.2	Site Clearing and Grubbing	6-2
6.2.3	Drainage	6-2
6.2.4	Erosion.....	6-2
6.2.5	Debris.....	6-3
6.2.6	Road Maintenance.....	6-3
6.2.7	Excavation, Filling, and Backfilling.....	6-3
6.2.8	Site Grading	6-3
6.3	SITE IMPROVEMENTS	6-3
6.3.1	Storm Water Drainage System	6-4
6.3.2	Sanitary System.....	6-4
6.3.3	Fencing and Gates.....	6-4
6.3.4	Crushed Stone Surfacing.....	6-4

6.3.5	Buildings and Equipment Foundation	6-4
6.3.6	Tank Foundation	6-5
6.3.7	Manholes	6-5
6.3.8	Duct Banks.....	6-5
6.3.9	Landscaping.....	6-5
6.3.10	Roads and Parking	6-5
6.3.10.1	Roads.....	6-6
6.3.10.2	Parking Areas.....	6-7
6.3.10.3	Plant Area Surfacing	6-7
6.3.10.4	Bollards	6-7
6.3.11	Oil/Water Separation.....	6-7
6.3.12	Unloading Areas	6-8
6.4.12	EVAPORATION PONDS.....	6-8
SECTION 7.0	7-1
7.1	MATERIALS.....	7-1
7.1.1	Steel.....	7-1
7.1.2	Concrete	7-2
7.2	STRUCTURAL LOADING	7-3
7.2.1	Dead Loads.....	7-3
7.2.2	Live Loads.....	7-3
7.2.3	Wind Loads.....	7-4
7.2.4	Seismic Loads.....	7-4
7.2.5	Thermal Loads	7-4
7.2.6	Crane Loads	7-4
7.2.7	Vehicle Loads	7-4
7.2.8	Pipe and Equipment Anchor Loads	7-4
7.3	STRUCTURAL FOUNDATIONS.....	7-5
7.4	ARCHITECTURAL	7-6
7.4.1	Siding/Panels	7-6
7.4.2	Roofing.....	7-6
7.4.3	Interior Construction Materials.....	7-6
7.4.4	Platforms	7-8
7.4.5	Stairs	7-8
7.4.6	Handrail.....	7-8

7.4.7	Windows, Window Walls, Entrance Doors, and Louvers.....	7-8
7.4.8	Painting	7-9
7.4.8.1	Surface Preparation	7-11
7.4.8.2	Prime Protective Coating for Steel	7-12
7.4.8.3	Finish Coating	7-12
7.5	BUILDINGS/STRUCTURES	7-12
7.5.1	Minimum Requirements.....	7-12
7.5.2	Steam Turbine Generator Building	7-14
7.5.3	Other Structures.....	7-14
7.5.4	HRSG Equipment Enclosure	7-14
7.5.5	Turbine Room Crane	7-14
	SECTION 8.0.....	8-15
8.1	GENERAL REQUIREMENTS	8-15
8.1.1	Plant System Studies.....	8-2
8.1.2	Interface Requirements	8-4
8.1.2.1	Utility System Interface.....	8-4
8.1.2.2	Plant Synchronizing and Switching Scheme Interface	8-7
8.1.3	Auxiliary Power Supply Equipment.....	8-7
8.1.4	Classification of Hazardous Areas.....	8-9
8.1.5	Lighting	8-9
8.1.6	Telephone and Data Systems	8-10
8.1.7	Construction Power.....	8-11
8.1.8	Freeze Protection.....	8-11
8.1.9	Cathodic Protection System	8-12
8.1.10	Lightning Protection	8-12
8.2	ELECTRICAL PROTECTIVE SYSTEMS	8-12
8.2.1	Generator Protective Relays.....	8-13
8.2.2	Generator Step-up Transformer Relays	8-13
8.2.3	Unit Auxiliary Transformer Relays	8-14
8.2.4	Medium Voltage Switchgear and Motor Controllers	8-14
8.3	SWITCHYARD	8-14
8.3.1	Deadend Structures.....	8-14
8.4	GENERATOR STEPUP TRANSFORMERS	8-15
8.5	PLANT AUXILIARY TRANSFORMERS.....	8-18

8.6	4160 VOLT METAL-CLAD SWITCHGEAR	8-21
8.6.1	General	8-21
8.7	4160 VOLT MOTOR CONTROL CENTERS	8-22
8.7.1	General	8-22
8.7.1.1	Codes and Standards.....	8-23
8.8	480 VOLT SECONDARY UNIT SUBSTATIONS.....	8-23
8.8.1	General	8-23
8.8.1.1	Codes and Standards.....	8-25
8.9	480V MOTOR CONTROL CENTERS	8-25
8.9.1	General	8-25
8.9.2	Circuit Breakers	8-26
8.9.3	Combination Starter Units.....	8-26
8.10	GENERATOR TERMINAL EQUIPMENT/ISOLATED PHASE BUS DUCT	8-27
8.10.1	GT Generator Bus Duct/Auxiliary Power Connections	8-27
8.10.2	Low Side Generator Breakers	8-28
8.10.3	ST Generator Bus Duct.....	8-28
8.11	NON-SEGREGATED PHASE BUS DUCT	8-29
8.11.1	General	8-29
8.11.2	Bus Enclosures	8-29
8.11.3	Bus Conductors	8-29
8.12	BATTERY/UPS SYSTEM.....	8-30
8.12.1	Codes and Standards	8-30
8.12.2	Design and Construction	8-30
8.12.3	Rating.....	8-31
8.12.4	Duty Cycle.....	8-31
8.12.5	Battery Charger Requirements	8-31
8.12.6	UPS Equipment Requirements.....	8-32
8.12.6.1	Static Inverter	8-33
8.12.6.2	Inverter Capacity	8-33
8.12.6.3	Static Transfer Switch	8-34
8.12.6.4	Manual Bypass Switch	8-35
8.12.7	Distribution Panelboards.....	8-35
8.12.8	Construction Details.....	8-36
8.13	EMERGENCY DIESEL GENERATOR.....	8-37
8.13.1	General	8-37

8.14	ELECTRIC MOTORS.....	8-37
8.14.1	4000 and 460 Volt Integral Horsepower Motors.....	8-38
8.14.2	Fractional Horsepower Motors.....	8-42
8.15	RACEWAY.....	8-42
8.15.1	Routing of Above Grade Raceway and Conduit.....	8-44
8.15.2	Electrical Cable Tray System.....	8-45
8.15.3	Covers.....	8-46
8.15.4	Tray Supports.....	8-46
8.15.5	Material.....	8-47
8.16	CONDUCTORS.....	8-47
8.16.1	Cable Specifications.....	8-49
8.17	GROUNDING.....	8-51
8.17.1	Ground Grid Design.....	8-52
8.18	PLANT SECURITY SYSTEM.....	8-53
8.19	ELECTRICAL TESTING.....	8-53
SECTION 9.0	9-1
9.1	GENERAL REQUIREMENTS.....	9-1
9.2	DISTRIBUTED CONTROL SYSTEM (DCS).....	9-3
9.3	DCS CONTROLLERS AND I/O.....	9-6
9.4	INTERFACES AND NETWORKS.....	9-8
9.5	REMOTE TERMINAL UNIT (RTU) DISPATCH.....	9-9
9.6	DCS FACTORY ACCEPTANCE TEST (FAT).....	9-9
9.7	HARD PANEL CONTROL BOARD.....	9-10
9.8	INSTRUMENTATION AND CONTROL DEVICES.....	9-10
9.8.1	General.....	9-10
9.8.2	Thermocouples and Resistance Temperature Detectors.....	9-10
9.8.3	Thermowells.....	9-11
9.8.4	Flow Elements.....	9-11
9.8.5	Transmitters.....	9-11
9.8.5.1	Static Pressure and Differential Pressure Transmitters.....	9-11
9.8.5.2	Level Transmitters.....	9-12
9.8.5.3	Flow Transmitters.....	9-12
9.8.6	Gas Meters.....	9-12
9.8.7	Temperature, Pressure, Level, and Flow Switches.....	9-12

9.8.8	Local Indicators	9-13
9.8.8.1	Thermometers	9-13
9.8.8.2	Pressure Gauges	9-13
9.8.8.3	Local Level Indicators (Gauge Glasses).....	9-13
9.8.9	Control Valves.....	9-13
9.8.10	Instrument Racks	9-14
9.8.11	Tubing Systems	9-15
9.9	CONTROL SYSTEM LOOP COMPONENT DESIGN	9-16
9.9.1	Gas Turbine Generator (GTG).....	9-16
9.9.2	Steam Turbine Generator	9-17
9.9.3	Heat Recovery Steam Generator (HRSG).....	9-18
9.9.3.1	HRSG Drum Level Control System	9-19
9.9.3.2	Duct Burner Safety System	9-19
9.9.3.3	Ammonia Injection Control System	9-19
9.9.3.4	Steam Temperature Control System	9-19
9.9.3.5	LP Drum Level Control System	9-19
9.9.4	Feedwater System	9-19
9.9.4.1	Condensate Receiver Tank Level Control.....	9-20
9.9.4.2	Boiler Feed Pump Minimum Flow Control	9-20
9.9.4.3	Boiler Feed Pump Existing Vibration Monitoring	9-20
9.9.5	Air Cooled Condenser (ACC) System	9-20
9.9.6	Water Treatment Systems	9-20
9.9.7	Fuel Gas Metering and Conditioning System	9-20
9.9.8	Plant Systems – Raw Water	9-21
9.9.9	Plant Monitoring System.....	9-21
9.10	HISTORICAL DATA STORAGE AND RETRIEVAL	9-21
9.11	CONTINUOUS EMISSIONS MONITORING SYSTEMS.....	9-21
9.12	ONLINE PERFORMANCE MONITORING SYSTEM	9-24
SECTION 10.0	10-1
SECTION 11.0	1
START-UP, INITIAL OPERATION AND PERFORMANCE TESTING	1
11.1	GENERAL	1
11.1.1	SUMMARY:.....	1

11.1.2 QUALITY ASSURANCE: 2
11.1.3 SUBMITTALS: 2
11.1.4 ACCEPTANCE AND PERFORMANCE TESTS:..... 3
11.1.5 EXECUTION 3

APPENDICES

A	ABBREVIATIONS.....	A-1
B	APPROVED VENDORS LIST	B-1
C	CONCEPTUAL SITE ARRANGEMENTS.....	C-1
	DM-011A-C: General Arrangement Site Plan	
	DM- 12A-0: Conceptual Combined Cycle Unit Plot Plan	
	DA-101-1: Admin/Control/Warehouse Building Floor Plan	
D	CONCEPTUAL PROCESS FLOW DIAGRAMS AND WATER BALANCE.....	D-1
	FD-1: Conceptual Process Flow Diagram	
	WB-1: Conceptual Water Balance	
E	CONCEPTUAL ELECTRICAL ONE - LINES	E-1
	SKE-1: Conceptual One Line Diagram	
F	PACIFICORP “Material Specification ZS 001-2004, Substation Equipment – Power Transformer All Ratings”	F-1
G	GEOTECHNICAL REPORT	G-1
	Currant Creek Preliminary Geotechnical Investigation Results	
H	LARGE GENERATION INTERCONNECTION AGREEMENT (LGIA)	H-1
I	MAKEUP WATER ANALYSIS.....	I-1
J	FUEL ANALYSIS.....	J-1
K	DATA TO BE COMPLETED WITH BID.....	K-1
L	PACIFICORP “6B.5 – Fence Application and Construction”	L-1
M	ENGINEERING DOCUMENTS, DRAWINGS & OTHER DELIVERABLES.....	M-1

SECTION 1.0

INTRODUCTION

1.1 General Plant Description

The Currant Creek Power Project is a natural gas-fired, electric generating plant being developed by PacifiCorp (Owner). The site is located in Juab County, approximately 80 miles south of Salt Lake City and 1 mile west of Mona, Utah, at an elevation of 5051ft. The existing Block 1 plant is a nominal 500MW power block consisting of the combined cycle operation of two (2) GE 7FA combustion turbines, two (2) Heat Recovery Steam Generators, and one steam turbine generator with an air-cooled condenser. This specification shall address the addition of a second 2 X 1 combined cycle power plant (Block 2) at the existing site.

The Block 2 power plant shall consist of two (2) GE Model 7FA or Siemens-Westinghouse SGT65000F (FD3 or FD4) or Mitsubishi M501F gas turbine generators (GTGs). Mitsubishi M501G machines will be considered. Exhaust gas from each GTG shall be directed into a dedicated heat recovery steam generator (HRSG) for the generation of high-pressure, intermediate-pressure, and low-pressure steam. Contractor shall optimize the design of the plant based on rated output, heat rate, and parasitic energy costs. This optimization shall include evaluation of economically attractive equipment such as natural gas preheater, HRSG duct firing and GTG output. Supplementary firing capability and power augmentation through steam injection shall be provided at Bidder's discretion in each HRSG to generate additional steam for peak power production. The steam generated in the HRSGs shall be supplied to a single tandem-compound, reheat bottom exhaust, steam turbine generator. Exhaust steam from the steam turbine shall be condensed in an air-cooled steam condenser (ACC).

Auxiliary cooling shall be accomplished through an air cooled, elevated heat exchanger with fan cooled sections that can be individually isolated, and two, 100 percent capacity Closed Cooling Water pumps.

The GTGs will be equipped with dry low-NO_x combustors. Each of the HRSGs shall have a selective catalytic reduction (SCR) system to further control NO_x emissions and an oxidation catalyst for carbon monoxide (CO) and volatile organic compounds (VOC)

emissions control. The GTGs and HRSG duct burners, if provided, will burn only natural gas.

The gas turbines, HRSGs, and all other major equipment, except for the steam turbine generator, shall be installed outdoors. The gas turbines will be installed in dedicated enclosures furnished with the equipment. A building shall be provided to enclose the steam turbine and shall include an overhead crane for maintenance. The existing administration building / warehouse provided under Block 1 shall be shared by both plants.

Power produced by the generators will pass through step-up transformers for delivery to the electrical transmission grid through a 345 kV switchyard.

Natural gas will be supplied to a single site interface point.

Raw Water will be supplied from the Owner's raw water supply well(s) to a new Raw Water Storage Tank.

Wastewater shall be collected in small sumps and ultimately discharged to an on-site evaporation pond.

Contractor shall provide base bid for power plant as described in this specification. Contractor may provide an alternate bid for power plant equipped for fast starting using new technology offerings from combustion turbine manufacturer. Fast start power plant shall include all upgrades, modifications and ancillary equipment required for the fast start capability. Bidder's proposal shall include a description of the guaranteed startup time improvement and description of equipment provided.

1.1.1 Specifications

1.1.1.1 General

The purpose of the Technical Specifications is to define the minimum scope, plant features, and quality standards for the design, procurement, construction, startup, and testing of the combined cycle power plant.

The Owner has provided a conceptual plant design for the purpose of permit applications and specifying the minimum scope and features of the facility. The conceptual design includes plant heat balances, process flow diagrams, one-line

diagrams, arrangement drawings, and plant water balances. The conceptual design is included in Appendix C through Appendix E as a part of the Technical Specifications. Contractor shall verify all aspects of the conceptual design and shall provide final design and detailed specifications and drawings for the plant in conformance with these Specifications. Contractor shall be responsible for all design of the power plant based upon this conceptual design. All conceptual drawings shall become the Contractor's responsibility, and Contractor shall modify or recreate all conceptual drawings to reflect actual design throughout the design and construction phases of the project. See Process Flow Diagram FD-1 included in Appendix D for a basic overview of the steam cycle.

Contractor shall utilize Vendors from Appendix B – Approved Vendors List whenever applicable. For the equipment listed, alternate vendors may be used with Owner approval only.

1.2 OVERALL SCOPE DESCRIPTION

1.2.1 General Scope

Contractor shall design, procure, fabricate, install, test, and commission a complete, functional, operating, power plant facility as specified herein with a high degree of reliability, integrity, maintainability, efficiency, and environmental compatibility which conforms to normally accepted standards for utility owned power generating facilities.

Except as specified otherwise, provide all equipment, materials, transportation services, labor, labor supervision, technical field assistance, scheduling, consumables, construction equipment, construction tools, special tools, construction utilities, permanent utilities, testing services, spare parts, and other services and items required for, or incidental to the engineering, design, procurement, installation, construction, startup, testing, commissioning, and training for the facility.

Design, fabricate, install, inspect, examine, and test each system in accordance with the specified industry standards and applicable Laws. Comply with all requirements of the Applicable Laws and Applicable Permits as specified in the Contract.

Perform specified, code required, and Contractor's standard quality assurance testing, inspection, examination, and documentation.

Submit design, fabrication, and quality assurance documentation, and operating and

maintenance manuals in accordance with the submittal requirements of Section 4.0 of these Specifications.

Except as specified otherwise, provide all transportation services required to transport equipment and materials from point of manufacture or point of origin to the Project Site and provide transportation on the Project Site to the area of installation as required to erect the equipment complete. Transportation services shall include supply and installation of any temporary or permanent transportation facilities required on or off Site as required to facilitate the delivery (i.e., road improvements and the like).

Except as specified otherwise, provide all technical assistance, equipment, and supplies required, specialized and non-specialized, for erection, testing, start-up, and commissioning of all components of the facility including those supplied by the Owner.

Coordinate start-up and commissioning operations with Owner's operating maintenance personnel and involve Owner's personnel in start-up and commissioning activities to the extent desired by the Owner.

Train Owner's operators and maintenance personnel on all operating and maintenance aspects of the facility prior to system start-up in accordance with Section 10.0 of this Exhibit A of the contract

Provide all planning, coordination, arrangements for leasing temporary equipment, installation of temporary equipment and commissioning of the project.

Fire protection during plant construction shall meet the requirements of NFPA 241. All fire protection systems shall be subject to the review and approval of the state and local fire department authorities.

Provide all special tools and lifting devices for equipment supplied by the Contractor as required for maintenance and operations for the intended life.

At the start of the project and continuing thereafter provide all technical advisories such as Technical Information Letters and Service Bulletins applicable to major equipment. Until the end of the warranty period all corrective measures available for known issues affecting operation, reliability or safety shall be supplied. For clarity, it is understood that this obligation would not include any product improvements or upgrades not necessary for safe and reliable operation.

Contractor shall complete all information requested in Appendix K – Data to be submitted with Bid and turn in as a part of Contractors proposal

1.2.2 Work by Others

Others will be performing work at the Site as part of this Project. Such contracts include the following:

1. 345 kV switchyard supply and installation, 345 kV overhead line, and high voltage connection to step-up transformers; Power and control termination cabinets located in the switchyard control building; Contractor to supply dead-end structures.

Contractor shall coordinate with other contractors as to avoid interference in operations, conduct operations to minimize inconvenience to these contractors, and confine operations to areas within the Contract limits. Construction laydown and parking areas shall be provided for these other contracts and shall be shared with these contractors.

1.2.3 Terminal Points

Boundaries associated with the scope of work for the Project are defined in the following paragraphs. The Contractor shall coordinate with all other contractors to fully define interface requirements and shall provide all facilities as defined and as required to provide a fully functional plant including interface with off-site systems provided by others.

1.2.3.1 345 kV Switchyard

Owner will furnish and install the 345 kV switchyard collector bus and transmission line. (Interface details will be furnished to Contractor at a later date). Unless otherwise specified, Contractor's interface point with switchyard shall be at the high side bushings on Generator Step-up Transformer. Contractor shall include step-up transformer dead end structure. Owner will bring overhead line from switchyard and make drops to transformer arresters and bushings.

Switchyard Relaying and Metering Interface: Switchyard contractor will provide a junction box inside the Switchyard Control Building for relaying and metering interface between the 345 kV Switchyard and the power plant. Provide all facilities required for

relaying and metering interface inside the power plant and between power plant and Switchyard junction box. Facilities shall include but not be limited to, ductbank, wiring, programming, controls, and relaying and metering equipment. Contractor shall make terminations on plant side of terminal blocks. Provide a minimum of 2 spare 4-inch conduits in the duct bank between power plant and Switchyard Extension.

RTU Communications: Contractor will provide a fiber optic connection from the switchyard RTU located in the switchyard control building to the plant DCS. Provide all facilities required for RTU communications between the power plant and Switchyard control building. Any I/O points required at RTU but not available in the DCS shall be hardwired to the RTU. Facilities shall include but not be limited to, ductbank, fiber, wiring, programming, and interface equipment.

Grounding: Extend plant grounding system at two locations per generator step-up transformer and connect to the switchyard extension grounding system. Connect any ductbank ground conductor to switchyard grid. Connect power plant fence grounding to the switchyard extension ground grid or electrically isolate the plant fence at all interfaces with the switchyard extension fence.

Fencing: Switchyard contractor shall provide a separate fence surrounding the switchyard. Contractor shall provide all other fencing and gates for the facility as required for Block 2 construction. Fencing shall be installed in compliance with "PacifiCorp Standard 6B.5-Fence Application and Construction" dated September 2007" as provided in Appendix L.

1.2.3.2 Natural Gas

Pipeline: Contractor shall connect to the existing Block 1 gas metering station for the supply of natural gas to Block 2 as indicated on the site plan. Provide all facilities downstream of this connection required by these Specifications, including but not limited to, pressure regulation, moisture scrubbers, gas heating, filters/separators, cathodic protection, and piping.

1.2.3.3 Water Supply

Pipeline: An 8-inch raw water supply pipeline already exists to the Block 1 Raw Water/Fire Water Storage Tank. The terminal point for Block 2 service water is on the

existing service water pumps supply line (1SWS-10"-151X9-F-91503) from the Raw Water/Fire Water Storage Tank. In addition, a connection has been provided for recirculation from the Block 2 service water pumps to the Raw Water/Fire Water Storage Tank. Contractor shall provide all facilities downstream of the supply line connection and upstream of the recirculation line connection as required by these Specifications including but not limited to, water flow meters, water storage tanks, water treatment systems, and water distribution systems.

1.2.3.4 Process Waste Water Discharge

CTG wash water shall be collected in separate covered drain sumps which shall be provided with hose connections for truck disposal. Equipment/floor drains shall be routed to an Oil/Water Separator. Process water from the Oil/Water Separator, boiler blowdown, water treatment backflush and excess condensate shall be routed to a collection sump where it shall be gravity fed to an evaporation pond. Contractor shall provide sumps and an evaporation pond as required by these specifications for Block 2. Provide all facilities upstream of the evaporation ponds to collect and deliver the process wastewater to the evaporation ponds.

1.2.3.5 Telephone and Data Communications

Communications: Telephone and data communication systems for the facility will be furnished and installed by the Contractor. The telephone and data communications system will be inter-connected with the systems already existing for the Block 1 plant. The new systems shall be compatible with those already installed. Provide panel boards in the administration building for connection by the telephone and data communications service provider. Provide all facilities, including but not limited to, wiring, jacks, switches, controls, and phones, on the plant side of the communications panels as required to provide a complete and functional plant communications system for both telephone service and data communications service.

Provide a conduit system from site interface point (to be identified later on General Arrangements) to the location of the panel boards for installation of the communications wiring by others.

1.2.4 Owner Furnished Equipment and Systems

The following equipment will be directly purchased by Owner:

1. 345 kV Switchyard - Owner will directly contract the plant switchyard supply and installation and electrical interconnection to the utility grid with Others.
2. Permanent Plant Spares – Owner will provide permanent plant spare parts as required to maintain an operating plant after plant start-up. Contractor shall supply all spare parts required to start-up the facility through Substantial Completion. Contractor shall provide a list of recommended permanent spare parts including unit price, pricing validity timeframe, quantity, description, OEM and OEM part number. The spare parts list shall include a list of all spare parts anticipated for three years of operation.

1.2.5 Noise Levels

1.2.5.1 Equipment Noise Requirements

1. Each Combustion Turbine Generator shall be purchased to meet near field noise requirements of 85 dBA when measured 3 feet in the horizontal plane from the equipment (or enclosure) in any direction and 5 feet from the ground or any personnel platform (without additional attenuation outside OEM scope).
2. The Steam Turbine Generator shall be purchased to meet near field noise requirements of 90 dBA when measured 3 feet in the horizontal plane from the equipment (or enclosure) in any direction and 5 feet from the ground (without additional attenuation outside OEM scope).
3. As a minimum, each HRSG shall be guaranteed to meet 67 dBA when measured 100 feet in the horizontal plane from the HRSG (or enclosure) in any direction and 5 feet from the ground.
4. As a minimum, each Transition Duct shall be guaranteed to meet 67 dBA when measured 100 feet in the horizontal plane from the transition duct in any direction. Attenuation, if required, from the CTG exhaust expansion joint through the HRSG transition duct shall be in Contractor's scope.
5. As a minimum, each HRSG exhaust stack shall be guaranteed to meet 56

dBa when measured 100 feet in the horizontal plane from the HRSG exhaust stack in any direction and 5 feet from the ground.

6. As a minimum, Contractor shall procure all engineered equipment with vendor guaranteed near field noise levels of 85 dBA when measured 3 feet in the horizontal plane from the equipment (or enclosure) in any direction and 5 feet from the ground or any personnel platform. Contractor shall make all reasonable efforts to enforce this criteria.
7. Contractor shall enforce all guarantees to correct equipment which is out of compliance.

Based upon a post construction noise survey completed by Contractor, Contractor shall post noise warning signs in all areas determined to exceed 85 dBA. Sound level measurements shall be made with a sound level meter that meets the requirements of the latest revision of ANSI S1-4 Type 1 or better. Sound level meter must be calibrated to within +/- 1 dB at the beginning and end of each measurement period. Measurements are to be performed in accordance with ANSI S12-23-1989 and S12-36-1990 for the near field. Exceedance areas must have Owner approval.

1.2.5.2 Indoor Noise Limits

Noise levels in normally occupied work areas, such as office and control room areas, shall be limited to 45 dBA.

1.2.5.3 Far Field Noise Guarantees

The far field noise levels shall not exceed guarantee limits at site boundaries as required by Federal, State, and local regulations. Far field noise guarantees must be met during all startup, operating, (including full bypass operation), shutdown, and trip conditions. Sound level measurements shall be made with a sound level meter that meets the requirements of the latest revision of ANSI S1-4 Type 1 or better. Sound level meter must be calibrated to within +/- 1 dB at the beginning and end of each measurement period. Far field noise measurements are to be performed in accordance with ANSI S12 9-1993 and ANSI S12 18-1994.

1.2.6 Mechanical Scope

The Mechanical Scope is summarized below and requirements are more fully described in Section 5 of these specifications.

Contractor shall supply, install, and commission all equipment and systems necessary for a complete and fully functional facility. The equipment and systems shall include, but shall not be limited to, the following:

1. Gas Turbine-Generators and systems
2. Steam Turbine-Generator and systems
3. Heat Recovery Steam Generators (HRSGs)
4. HRSG Vents and Drains
5. Steam Systems (including bypass system)
6. Air Cooled Condenser (ACC)
7. Condensate System
8. Feedwater System
9. Service Water System including Raw Water Storage Tank Conversion
10. Water Treatment System and Demineralized Water Storage Tank
11. Cycle Makeup and Storage System
12. Closed Cooling Water System
13. Potable Water for eyewash stations and as required
14. Aqueous Ammonia Storage and Transfer System
15. Fire Protection System extension for Block 2 with new storage tanks and fire pumps
16. Chemical Treatment and Injection System
17. Sampling System
18. Bulk Gas Storage Systems (CO₂ , H₂ and N₂)
19. Fuel Gas System
20. Instrument/Service Air System
21. Heating, Ventilating, and Air Conditioning (HVAC) System
22. Plant Blowdown System
23. Plant Drains System
24. Wastewater Treatment System

25. Wastewater Collection and Disposal (including oily wastewater)
26. Sanitary Drainage System
27. All Miscellaneous Mechanical Systems and Equipment
28. All temporary facilities and systems needed to implement this work

1.2.7 Electrical Scope

The Electrical Scope is summarized below, and requirements are more fully described in Section 8 of these Specifications.

Contractor shall supply all equipment and systems necessary for a complete and fully functional facility. The equipment and systems to be provided shall include, but shall not be limited to, the following:

1. Generator Step-up and Auxiliary Transformers
2. Low Side GTG Generator Breakers
3. Isophase Bus Duct System
4. Medium-Voltage System including switchgear and MCCs
5. Low-Voltage System including switchgear and MCCs
6. Direct Current (DC) Power System
7. Uninterruptible Power Supply (UPS)
8. Communication System expansion
9. Security System expansion
10. Emergency generator
11. Lighting
12. Grounding
13. Cathodic Protection
14. Heat Tracing
15. Data/telephone expansion
16. Lightning Protection
17. All Miscellaneous Electrical Systems and Equipment

18. Construction Power System

1.2.8 Instrumentation and Control Scope

The Instrumentation and Controls Scope is summarized below, and requirements are more fully described in Section 9 of these Specifications.

1. Fully Integrate Block 2 Control Room equipment into existing Block 1 Central Control Room utilizing equipment and programs similar to those used on Block 1
2. Distributed Control Systems and PLC's
3. Recording devices and Historians
4. Sequence of Events Recording
5. Hard-Wired Emergency Trips and Critical Interlocks
6. Continuous Emission Monitoring Systems
7. Performance Monitoring System
8. Instrumentation and Control Devices

1.2.9 Civil Scope

The Civil Scope is summarized below, and requirements are more fully described in Section 6 of these Specifications.

1. Geotechnical Investigations
2. Topographic Construction Surveys
3. Site Preparation
4. Permanent Site Drainage
5. Drainage During Construction
6. Interface with connection to wastewater treatment destination
7. Construction Wastewater Treatment and Disposal
8. All Sub-grade Work and Foundations
9. All Final Grading
10. Roads and Paving including Parking Areas
11. Fencing

1.2.10 Structural and Architectural Scope

The Structural and Architectural Scope is summarized below, and requirements are more fully described in Section 7 of these Specifications.

1. Structural Materials
2. Concrete
3. Steam Turbine-Generator Building
4. Overhead crane
5. Steel including Pipe Racks and Supports
6. Siding and Roofing
7. Miscellaneous Buildings
8. Water Sample Laboratory
9. Painting

1.2.11 Construction Facilities and Services

1.2.11.1 General

Contractor shall furnish and maintain temporary construction facilities and provide construction services including, but not limited to the following:

1. Temporary Storage Facilities at the Site for the proper unloading and storage of all plant material delivered to the Site. If adequate facilities are not available, such material shall be stored at suitable offsite facilities (e.g., warehouses, storage yards, etc.). Laydown and storage areas shall be indicated on the General Arrangement Site Plan in Appendix C.
2. Contractor to provide all permits required for construction.
3. Construction Power and Distribution. Contractor shall be responsible for all electric power tie-ins at the Site.
4. Temporary communication system
5. Temporary lighting system
6. Site drainage, erosion and sedimentation control, and dewatering systems

7. Temporary roads
8. Fire protection service (until Substantial Completion)
9. Construction sanitary facilities including construction offices
10. Temporary water supply and distribution (potable and non-potable). Potable water shall be high quality bottled water.
11. Parking Facilities. Contractor shall furnish adequate parking facilities to accommodate all construction work forces as indicated on the General Arrangement Drawing in Appendix C.
12. Site Security. Contractor shall be responsible for providing the fencing, guarding, and watching the Site as necessary for protection during construction (until Final Completion).
13. Construction testing services (e.g. weld NDE, hydrotesting, megger testing, concrete strength and placement, compaction testing, steel testing etc.).
14. Construction Materials - Contractor shall supply all the equipment, tools, consumables, instruments, etc., necessary for the construction and erection of the plant. The supply of the construction equipment shall include fuel, lubricants, spare parts, and any other elements or service required for operation and maintenance.
15. Site environmental compliance and protection.
16. First Aid Services. Contractor shall provide onsite first aid services in conjunction with arrangement for offsite first aid transportation and treatment as necessary during the construction of the plant.
17. Temporary Construction Facilities at the site to support Contractor's construction staff and labor force, and the delivery, unloading and storage of equipment and materials.

1.2.11.2 Coordination

Contractor and any other parties involved in the construction of the project shall attend such pre-construction and construction meetings as may be requested by Owner. At the

initial meeting, Contractor shall present a construction plan including, but not limited to, the following: safety, procurement plan, major equipment receipt plan, construction sequence, methods and equipment to be used in all phases, tentative access and right-of-way roads, locations of staging areas, regrading of roads, moving of equipment/property that will interfere or impact construction and a construction schedule showing all activities for the entire construction phase of the project. All construction related activities shall be in compliance with PacifiCorp's "Construction Coordination Agreement".

Contractor shall be responsible for contacting all involved utility companies prior to starting any work to determine schedule of work and location of all temporary and permanent facilities in the project area.

Contractor shall prepare an outage plan for all scheduled interruptions of electrical power or other utilities-interference that would affect third parties. This plan shall be submitted by Contractor to Owner and the affected parties at least thirty (30) days prior to outage.

Representatives of Contractor shall attend weekly coordination meetings to discuss matters relative to the progress and execution of the construction and startup of the project. Current week progress and three-week look ahead schedules (Level 2 or better) shall be presented by the Contractor and reviewed at these meetings in addition to other site coordination items.

1.2.11.3 Safety

Contractor shall implement and maintain, throughout the construction period, a written safety and accident prevention program which meets the requirements of federal, state, and local codes and regulations, and all other authorities having jurisdiction over this work. Subcontractors and vendor-supplied service organizations will each be required to implement a safety program commensurate with the work to be performed and in compliance with Contractor's Site Safety Plan.

Contractor's Safety, Health, and Accident Prevention Program shall be submitted to Owner for approval and shall include disciplinary procedures and safety orientation training procedures applicable to the Contractor and his subcontractor personnel. Special emphasis shall be applied to ensure the use of personal safety equipment and

strict adherence to fall protection standards.

Contractor shall include a qualified on-site health, safety and security coordinator who, unless otherwise approved by the Owner in writing, shall have no other duties. The health and safety coordinator shall be on-site during all hours of construction and shall have authority to:

1. Identify unsafe conditions or practices to Construction management for correction.
2. Instruct Construction management when a work stoppage is necessary to correct an unsafe act or condition. Work with Construction management to develop a safe work approach to correction unsafe site conditions.
3. Investigate and respond to Owner identified safety concerns.

The Contractor shall hold regular scheduled safety meetings to instruct his personnel and subcontractor personnel in safety and health practices. The Contractor shall maintain accurate accident and injury reports and shall furnish Owner a monthly summary of injuries and man-hours lost due to injuries and copies of all accident and injury reports.

1.2.11.4 Security

Contractor shall prepare and implement a Site Security Plan. Contractor shall cooperate with the Owner on all security matters. A copy of the Site Security Plan shall be provided for information to the Owner.

1.2.11.5 Fire Protection

Only work procedures which minimize fire hazards to the extent practicable shall be used. Combustion debris and waste materials shall be collected and removed from the site each day. Fuels, solvents, and other volatile or flammable materials shall be stored away from the construction and storage areas in well marked, safe containers. Good housekeeping is essential to fire prevention and shall be practiced by the Contractor throughout the construction period. The Contractor shall follow the recommendations of the AGC "Manual of Accident Prevention in Construction" regarding fire hazards and prevention.

Formwork, scaffolding, planking, and similar materials which are combustible but which are essential to execution of the work shall be protected against combustion resulting from welding sparks, cutting flames, and similar fire sources.

Contractor shall provide qualified personnel for fire control as appropriate. Contractor shall provide adequate fire protection equipment in each warehouse, office and other temporary structures, and in each work area that he is occupying. Access to sources of firewater shall be kept open at all times. Suitable fire extinguishers shall be provided in enclosed areas, in areas that are not accessible to fire water, or in areas that may be exposed to fire that cannot be safely extinguished with water. Each fire extinguisher shall be of a type suitable for extinguishing fires that might occur in the area in which it is located. In areas where more than one type of fire might occur, the type of fire extinguisher required in each case shall be provided. Each extinguisher shall be placed in a convenient, clearly identified location that will most likely be accessible in the event of fire.

Contractor alone shall be responsible for providing adequate fire protection of the construction areas. Failure of Contractor to comply with, or Owner or Owner's Engineer to enforce, the above requirements shall not relieve Contractor from any responsibility or obligation under this Contract.

1.2.11.6 Cleanliness

Special attention shall be given to keeping the structures and surrounding grounds clean and free from trash and debris. The Contractor shall require all disciplines to thoroughly clean their work areas each working day. The Contractor's Construction Manager shall be responsible for Site maintenance and cleanliness. This shall include sweeping the floor, collecting and disposing of trash, and all other functions required to keep the site clean. All hoses, cables, extension cords, and similar materials shall be located, arranged, and grouped so they will not block any accessway and will permit easy cleaning and maintenance.

A roll-up of all hoses, welding leads and electrical cords will be executed once a month as a minimum or as determined by site management. Material and equipment not required for immediate use or installation will be stored in designated laydown and warehouse areas.

All trash, debris, and waste materials shall be collected, sorted, and deposited in waste collection receptacles near the work. These receptacles shall be emptied regularly and the waste properly disposed of off-site.

Promptly upon the completion of a construction task, the Contractor shall thoroughly clean the equipment or structure affected by the task activity by removing all accumulations of dirt, scraps, waste, oil, grease, weld splatter, insulation, paint, and other foreign substances. The Contractor, without additional cost or burden to the Owner, shall properly and adequately restore surfaces damaged by deposits of insulation, concrete, paint, weld metal, or other adhering materials.

1.2.11.7 Signs and Barricades

All signs and barricades shall be provided and maintained by Contractor and shall be in accordance with jurisdictional regulations for accident prevention.

1.2.11.8 Dust Control

Contractor shall be responsible for dust control at the Site. Contractor shall prevent the spread of dust during its operations. Contractor shall moisten all surfaces with water to reduce the risk of dust becoming a nuisance to the public and neighbors. Contractor shall furnish all labor and equipment necessary for dust control including tank trucks and hoses to apply Owner furnished water. Contractor shall conform to all requirements of the Applicable Permits.

1.2.11.9 Open Burning

On Site open burning will not be permitted.

1.2.11.10 Cooperation with Other Contractors

During the process of the work, it may be necessary for other contractors to be present on or about the site. Contractor shall afford all reasonable cooperation to such other contractors.

Contractor, if required, shall exchange with other contractors furnishing associated equipment, all necessary drawings and other information required to be furnished under the specifications of the respective contracts. Three (3) copies of all drawings and correspondence relating to information exchanged between Contractor and other

contractors shall be sent to Owner.

1.2.11.11 Energized Facilities

Contractor may encounter at the site existing energized facilities, operating machinery, and systems, which must remain energized and functional during the execution of the work.

Contractor shall be completely responsible for the safety and protection of his personnel, Owner's personnel, and the public on the site of the Work and shall employ all methods necessary to achieve such safety and also assure continuity of all service systems encountered. These methods shall include, but not be limited to, providing barriers, guard structures, insulating guards and sleeves, warning signs, and prevention of unauthorized access to service system areas.

1.2.11.12 Reference Points

Contractor shall establish baselines, monuments, and reference points for construction as necessary to proceed with layout of the work. Contractor shall be responsible for laying out the work to such lines and grades indicated on the drawings, and shall protect and preserve the established reference points, subject to changes as the Owner may direct.

1.2.11.13 Dangerous Materials

Contractor shall not use explosives, radioactive, or other dangerous material without prior notification to the Owner. Contractor shall be responsible for the proper handling, transporting, storage, and use of such materials. When the use of such materials or methods is necessary, Contractor shall exercise the utmost care and carry on such activities under supervision of its properly qualified personnel. Contractor, at its expense, shall repair any damage caused by its handling, transporting, storage, and use, and shall be responsible for obtaining permits as applicable.

1.2.11.14 Waste Disposal

Contractor shall keep Project Site free at all times from accumulations of waste materials and rubbish. Special attention shall be given to keeping the structures and surrounding grounds clean and free from trash and debris. Contractor shall require all disciplines to thoroughly clean their work areas each working day. Contractor's Construction Manager

shall be responsible for Site maintenance and cleanliness. This shall include sweeping the floor, collecting and disposing of trash, and all other functions required to keep the site clean. All hoses, cables, extension cords, and similar materials shall be located, arranged, and grouped so they will not block any accessway and will permit easy cleaning and maintenance.

A roll-up of all hoses, welding leads and electrical cords will be executed once a month as a minimum or as determined by site management. Material and equipment not required for immediate use or installation will be stored in designated laydown and warehouse areas.

All trash, debris, and waste materials shall be collected, sorted, and deposited in waste collection receptacles near the work. These receptacles shall be emptied regularly and the waste properly disposed of off-site.

Promptly upon the completion of a construction task, Contractor shall thoroughly clean the equipment or structure affected by the task activity by removing all accumulations of dirt, scraps, waste, oil, grease, weld splatter, insulation, paint, and other foreign substances. Contractor, without additional cost or burden to Owner, shall properly and adequately restore surfaces damaged by deposits of insulation, concrete, paint, weld metal, or other adhering materials.

1.2.11.15 Hazardous Material Management

Contractor shall be responsible for managing hazardous materials and hazardous wastes. Contractor shall be responsible for designating and managing storage areas, preparing plans, obtaining necessary permits, record keeping and reporting requirements in compliance with applicable, local, state and federal regulations. Owner will obtain an EPA I.D. Number to be used for manifesting hazardous waste.

1.2.11.16 Adjoining Utilities

Contractor shall make necessary efforts to protect any and all parallel, converging, and intersecting electric lines and poles, telephone lines and poles, highways, waterways, railroads, and any and all property from damage as a result of its performance of the work. Contractor shall bear all liability for and shall at its expense repair, rebuild or replace any property damaged or destroyed in the course of its performance of the work.

1.2.12 Production Inputs

Owner will provide the following Production Inputs:

1. Fuel gas for startup and commissioning of the plant, with quality as indicated in Appendix J
2. Water for construction and commissioning of the plant with quality and quantity as indicated in Appendix I. Water required for construction and commissioning in excess of those quantities shall be provided by Contractor.
3. Electricity input into the plant for startup and commissioning of the plant from the auxiliary transformers or backup power source. Construction power shall be provided by Contractor.

Contractor shall provide the following Production Inputs:

1. All Chemicals including, but not limited to, water treatment chemicals, boiler treatment chemicals, ammonia, and ethylene glycol for operation of systems during startup and commissioning of the plant.
2. All Gases including, but not limited to Nitrogen, Carbon Dioxide, Hydrogen, and CEM gases for operation of systems during startup and commissioning of the plant.
3. Lube oils necessary for flushing and operation of systems during startup and commissioning of the plant.

1.2.13 Operating Consumables

Until Substantial Completion is reached, Contractor shall provide (at Contractor's cost) all Operating Consumables, including initial fill and other consumables required for preparation, startup, and commissioning of the power plant including but not limited to the following:

1. Demineralized water
2. Water Conditioning Chemicals

3. Grease
4. Lubricants
5. Chemicals required during construction of the plant (such as boiler chemical cleaning chemicals)
6. Purging gases
7. Filters
8. Strainers
9. Spare parts such as gaskets, filter cartridges, light bulbs, lamps, fuses, and related items

1.3 PLANT OPERATING PROFILE

1.3.1 Plant Load Definition

For the purpose of these Specifications, the following plant load definitions shall be used.

Load Point	Gas Turbine Output	HRSG Output	Steam Turbine Output
Peak	2 @ Base Load	Maximum Duct Burning & power augmentation (if provided)	Turbine Follow/Sliding Pressure
Base	2 @ Base Load	No Duct Burning	Turbine Follow/Sliding Pressure
Minimum	1 @ 50% Base Load or OEM operating minimum	No Duct Burning	Turbine Follow/Pressure Control
Bypass	2 @ Base Load	No Duct Burning	Steam Turbine Bypassed

1.3.2 Plant Operating Profile

Operating conditions are expected to vary seasonally with periods of cyclic operation to minimum load or shutdown at night and periods of base load operation with daily duct firing for peak operation.

Contractor shall provide a plant designed to operate continuously at all load conditions between Minimum and Peak operation as indicated above and meeting all the requirements of the Contract, and operating within the limits of all Applicable Permits at any operating point within this range.

Annual plant starts to be utilized for design are as follows:

Cold (> 72 hour shutdown)	12
Warm (24-72 hour shutdown)	55
Hot (< 24 hour shutdown)	263

Contractor shall provide a system designed to start-up, shutdown, and operate as required and within the time frames specified in the Contract.

Contractor shall provide a plant designed to allow continuous bypass operation as defined above, with all steam being bypassed around the steam turbine to the ACC system and without any steam being vented to the atmosphere. Plant shall be capable of full bypass operation while allowing Owner to work on non-operating unit (except STG).

1.3.3 Plant Operating Philosophy

Design plant with suitable equipment, automation, and controls to allow plant to start-up, operate normally at any load between Minimum load and Peak load, and shutdown with one operator in the control room and one operator in the plant. Provide plant with suitable automation consistent with the requirements.

1.3.4 Plant Reliability

In general, provide a plant with full redundancy of all equipment and systems prone to failure that are required to support operation of the plant in Peak Load operation and all

equipment or systems for which a failure during any operation (Minimum, Base, Peak, or anywhere in between) could result in damage to the equipment or to the system.

Where redundant (standby) equipment is supplied, the idle component shall be capable of automatic and immediate initiation into operation upon failure of one or more of the operating components. Necessary instrumentation shall be supplied to sense a failure of one or more of the operating components.

1.3.5 Plant Performance

Design plant to optimize performance (output and heat rate) at the Plant Design Base Load conditions with capability of operating at all other design loads between the Minimum and Peak Loads.

Design plant to provide maximum Peak output at the Plant Design Peak Load conditions indicated in Table 2-1.

SECTION 2.0

SITE DESIGN CONDITIONS

The Currant Creek Power Project Site is located approximately 80 miles south of Salt Lake City, Utah. A Site location map is included in Appendix C, CONCEPTUAL SITE ARRANGEMENTS.

Specific Site design conditions are summarized in Table 2-1.

Table 2-1
Site Design Conditions

Plant Design Base Load Ambient Conditions: (Average Ambient Dry Bulb Temperature/ Coincident Wet Bulb Temperature)	95°F DBT 66°F WBT
Plant Design Peak Load Ambient Conditions: (Average Peak Dry Bulb Temperature/Coincident Wet Bulb Temperature)	95°F DBT 66°F WBT
Maximum Ambient Design Conditions: (Maximum Dry Bulb Temperature/Coincident Wet Bulb Temperature)	110°F DBT 64°F WBT
Minimum Ambient Design Conditions: (Minimum Dry Bulb Temperature/Coincident Relative Humidity)	-21°F DBT -21°F
Elevation	5051 ft above mean sea level
Location	Mona, Utah
Seismic Criteria	See Section 7.2.4 of Exhibit A
Wind Design	See Section 7.2.3 of Exhibit A
Precipitation	
Average Annual Precipitation	14.5 in. *
Maximum 24 hr Precipitation	1.85 in. *
Average Annual Snowfall	44.5 in.*
Maximum 24 hr Snowfall	19 in.*

Design Maximum Rainfall Rate	25 year/24 hour storm
Design Frostline:	As identified by local building code
Fuel	
Primary	Natural Gas
Backup	None
Preheating for starting	As specified by the gas turbine manufacturer but no less than 150 degrees F whichever is greater.. Minimum superheat 50°F.
Preheating for performance	As required by GTG Manufacturer
Supply Pressure at Owner interface point (regulation by contractor)	525 psig
* Data from the Western Regional Climate Center for Nephi, Utah.	

2.1 GEOTECHNICAL CONDITIONS

Results from the Preliminary geotechnical Investigation completed at the Currant Creek site are contained in APPENDIX G, GEOTECHNICAL REPORT. Contractor shall be responsible for dealing with the Geotechnical conditions at the site and may at its option, rely on the GEOTECHNICAL REPORT furnished by Owner. If Contractor believes that additional geotechnical investigations are necessary, it is Contractor's responsibility to perform any additional studies required at no additional cost to Owner. Relying on Owner's GEOTECHNICAL REPORT will not release Contractor from responsibility for the geotechnical integrity of the constructed facilities. Any subsurface anomalies discovered by the Contractor shall be reported immediately to the Owner.

2.2 SITE SECURITY

From the time of initial mobilization to Substantial Completion, Contractor is responsible for security and entrance to the power plant construction area, office trailer area, construction parking area, and laydown areas (Others will control access to switchyard areas). Security will include fencing areas as they come under construction and are completed, secured warehousing of plant equipment and materials and security guards, Contractor is responsible for controlling visitor access and site visits.

2.3 SITE ACCESS

Contractor shall establish a temporary access point into the site and to any temporary

staging / laydown areas, as required. Contractor shall construct and maintain access to laydown area(s). Laydown areas will be rough graded by Contractor. Any additional preparation required for the laydown areas shall be Contractor's responsibility. Contractor shall restore the laydown area to Owner's satisfaction upon completion of use.

Construction of the proposed facility will follow all permit requirements and engineering design specifications. Owner and/or his representatives will be onsite continuously to monitor that construction is in compliance with all permit and design specification requirements. The plant shall be constructed without obstructing public thoroughfares. All warning and traffic signs shall be provided and maintained. A safe workplace environment shall be maintained. The proposed facility site and roadway layout is shown on the site plan and general arrangement drawings. Contractor is required to meet the safety requirements outlined in paragraph 4.9 of the Contract.

2.4 SITE ENVIRONMENT

Contractor shall be responsible for protecting and maintaining the site, which shall include but not be limited to the following:

Proper storage and disposal of all materials, waste and contaminants such as debris, paints, solvents, lubricants, oils, etc. will be required at all times. No materials, wastes or contaminants shall be disposed of on-site. Records of all disposals shall be retained and provided to Owner at the end of the project. Contractor must maintain MSDS information for all materials brought to the site. All waste must be handled in accordance with the applicable local, state, and federal regulations.

Contractor shall maintain the project site in a neat and clean condition at all times. Materials shall be protected from damage due to dirt, debris or the elements. Upon completion, all temporary buildings, rubbish, unused materials and other equipment and materials belonging to and used in the performance of the work shall be disposed of. During construction, storm water and fugitive dust emissions shall be controlled by use of proper construction practices or other suitable means.

SECTION 3.0

CODES, STANDARDS, AND REGULATIONS

The editions and addenda of the following Codes and Publications effective as of the effective date of the Contract shall apply to all work performed under this Contract.

AASHTO	American Association of State Highway and Transportation Officials
ABMA	American Boiler Manufacturer's Association
ACI	American Concrete Institute
AFBMA	Anti-Friction Bearing Manufacturers Association
AGA	American Gas Association
AGMA	American Gear Manufacturers Association
AISC	American Institute for Steel Construction
AISI	American Iron and Steel Institute
AITC	American Institute of Timber Construction
AMCA	Air Moving and Conditioning Association
ANSI	American National Standards Institute
API	American Petroleum Institute
ASCE	American Society of Civil Engineers
ASHRAE	American Society of Heating, Refrigeration and Air Conditioning Engineers
ASME	American Society of Mechanical Engineers
ASNT	American Society for Nondestructive Testing
ASTM	American Society for Testing and Materials
AWWA	American Water Works Association
AWS	American Welding Society
BOCA	Building Officials and Code Administrators International
CAGI	Compressed Air and Gas Institute
CMMA	Crane Manufacturers Association of America
CFR	Code of Federal Regulations
CTI	Cooling Tower Institute
DEP	Division of Environmental Protection
EEl	Edison Electrical Institute

EJMA	Expansion Joint Manufacturing Association
EPA	United States Environmental Protection Agency
FAA	Federal Aviation Agency, Department of Transportation
FED	Federal Standards
FM	Factory Mutual
HEI	Heat Exchange Institute
HI	Hydraulic Institute Standards
IBC	International Building Code
IEEE	Institute of Electrical and Electronics Engineers
IES	Illuminating Engineers Society
IMC	International Mechanical Code
IPC	International Plumbing Code
IPCS	Insulated Power Cable Society
ISA	Instrument Society of America
LPC	Lightning Protection Code
MBMA	Metal Building Manufacturers Association
MSS	Manufacturers Standardization Society of the Valve and Fittings Industry
NAAMA	National Association of Architectural Metal Manufacturers Metal Bar Grating Manual
NACE	National Association of Corrosion Engineers
NAFM	National Association of Fan Manufacturers
NBBPVI	National Board of Boiler and Pressure Vessel Inspectors
NIBS	National Bureau of Standards
NEC	National Electric Code
NEMA	National Electrical Manufacturers Association
NESC	National Electric Safety Code
NETA	National Electrical Testing Association
NFPA	National Fire Protection Association
NSF	National Sanitation Foundation
OSHA	Occupational Safety and Health Administration
PPI	Plastic Pipe Institute
PFI	Pipe Fabrication Institute
RMA	Rubber Manufacturers Association
SAE	Society of Automotive Engineers

SDIS Steel Deck Institute Standards
SJIS Steel Joist Institute Standard
SMACNA Sheet Metal and Air Conditioning Contractors National Association
SSPC Steel Structures Painting Council
TEMA Tubular Exchanger Manufacturers Association
TIMA Thermal Insulation Manufacturers Association
UBC Uniform Building Code
UL Underwriter Laboratories Incorporated
UMC Uniform Mechanical Code
UPC Uniform Plumbing Code
UUBSAR Utah Uniform Building Standard Act Rules, R156-56
State of Utah Environmental Protection Agency
PacifiCorp Document – “Construction Coordination Agreement”
Juab County Ordinances and local municipal codes as applicable

Contractor shall obtain Owner approval for any deviations to these standards or alternative standards. Request for deviation or alternate shall include an explanation why such change is necessary and how compliance is to be achieved. Owner reserves the right to reject any such request for any reason. If Contractor discovers any conflict between any code, standard, or regulation, Contractor shall notify Owner of such conflict. Owner, in its sole discretion, shall then choose which provision shall take precedence over such conflicting provision.

SECTION 4.0

ENGINEERING SCOPE

4.1 GENERAL REQUIREMENTS

This Section covers the scope of the engineering services to be provided by the Contractor. Contractor (or Contractor's Engineer) shall perform all design engineering work including but not limited to the following items:

1. Prepare design documents, size equipment, generate drawings and specifications, and other supporting activities to the degree of detail required to fully and clearly define manufacturing and construction work requirements and minimize design engineering work in the field.
2. Prepare calculations as required for design decisions, equipment and material selection, and preparation of construction drawings.
3. Prepare system descriptions indicating equipment data, operating characteristics, functions, flow rates, and other process information for all plant systems.
4. Prepare mechanical, electrical, and instrument equipment lists with summary descriptions, vendors, and pertinent data.
5. Develop the detailed Site arrangement including provisions for locations of structures, equipment, and permanent access routes.
6. Coordinate receipt of information and materials so that all phases of the Project are well coordinated.
7. Develop and maintain a detailed electronic 3-D model of the plant. The 3-D model shall be used in design and in scheduled and unscheduled reviews and coordination meetings to assure that unnecessary interferences and rework are avoided.
8. Prepare arrangement drawings for Owner's Review and finalize arrangement drawings for construction.
9. Prepare Piping and Instrumentation Diagrams (P&ID's) for all Mechanical Plant Systems.
10. Provide all civil, electrical, instrument and control, mechanical, and structural construction drawings for the plant and supporting systems, including, but not limited to, the following:
 - A. Site Arrangement

- B. Plant Arrangement
- C. Control Room and Electrical Room Arrangements
- D. Access Roads, Curbs, Walkways, and Parking
- E. Evaporation Ponds
- F. All Grading
- G. All Site Fencing
- H. Wastewater Evaporative Ponds
- I. All Drainage
- J. Foundations and Equipment Pads (excluding the switchyard extension)
- K. Ductbanks and Manholes
- L. Structural Steel, Platforms, and Stairs
- M. Architectural Plans, Elevations, and Details
- N. Water and Wastewater Supply and Treatment Systems
- O. Equipment Location Plans and Elevations
- P. Above Grade Piping 2-½ Inches and Larger
- Q. All Below Grade Piping
- R. Steam Blow and Cycle Flush Piping
- S. Pipe Supports Including Hanger Designs
- T. Conduit, Cable, and Raceway
- U. Fire Protection Systems
- V. One-Line Electrical Diagram
- W. Three-line Electrical Diagram (generator and auxiliary voltages only)
- X. Underground Utilities and Yard Piping
- Y. Grounding Protection
- Z. Lightning Protection
- AA. OEM Packages
- BB. Lighting (excluding switchyard extension) and Communication
- CC. Power and Control Wiring
- DD. CEM Systems
- EE. Instrument Location Plan and Installation Details
- FF. Electrical Schematics and Interconnect Diagrams
- GG. Instrumentation Lists, DCS System Architecture Drawings to include all interfaces by hardwire and software to peripheral systems, DCS Control Loops, Logic Diagrams, Conceptual Graphic Displays, and related items.

11. Prepare technical specifications and other documentation to support all equipment procurement, materials, and construction requirements.
12. Obtain necessary plan approvals and building permits from appropriate state, county and local building authorities. Fees to building authorities shall be paid by Contractor.
13. Maintain a document control system on site from which updated documents and drawings shall be provided to the Owner as soon as update is issued.

All Architectural, Civil, Structural, Mechanical, Electrical, and Instrument and Control design documents that are issued for construction or procurement shall be prepared by or under the direct supervision of a registered professional engineer or architect according to the requirements in the State of Utah. Each engineer responsible for the design shall stamp or certify that the design documents have been prepared by or under his direction. Such design documents shall include, but are not limited to, all purchase and construction specifications, arrangement drawings, elevations, structural drawings, civil drawings, foundation designs, P&ID's, equipment arrangements, piping layouts, pipe stress analysis, electrical three-line diagrams, and electrical one-line diagrams.

Equipment, piping, valves, instrumentation etc. shall have consistent nomenclature throughout the documents.

Owner reserves the right to review all engineering documents and records produced by Contractor at any time.

A set of design and vendor drawings and specifications shall be issued to the Owner one year before the scheduled commercial date for use by the Owner's O&M team.

Upon completion of the Project, provide an as-built technical engineering library including all engineering calculations, design documents, and other technical records produced by Contractor. The as-built technical library shall be in hard copy and electronic form.

4.1.1 Architectural Design

Provide architectural design for all buildings, areas, and spaces described in these Specifications in accordance with the applicable specifications and code requirements.

Review local codes and prepare preliminary conceptual drawings for review by regulatory bodies to obtain building permits, and other permits for construction related activities.

4.1.2 Civil / Structural Design

Provide all design engineering and technical support for final arrangements, site grading, roads, site drainage, storm water diversion channels, parking, Site security, final paving, site improvements, site utilities, and construction surveys within the Site boundary.

Design yard piping and prepare yard piping drawings for all underground piping.

Provide all design engineering for construction facilities including access roads, laydown areas, parking lots, drainage, evaporation ponds, and construction utilities.

Provide analysis and detailed design for major plant equipment foundations.

Provide detailed design for structures including foundations, concrete and reinforcing steel, structural steel, platforms, stairs, and enclosures.

Provide architectural plans and sections for all building indicating general layout, permanent fixtures, finishes, and other architectural features.

4.1.3 Mechanical Design

Prepare plant heat balances to reflect in-progress and final design for both 2x1 and 1x1 operation. Heat balances shall be provided for Minimum Load, Base Load, and Peak Load, with and without duct firing, operating at the following Ambient Conditions:

-10°F, 0°F, 20°F, 40°F, 52°F, 60°F, 80°F, 95°F, and 100°F

Heat balances shall include evaporative cooling / chillers at temperatures above 55°F. Contractor has the option to provide duct burning and power augmentation. If provided, heat balances should be provided reflecting these options.

Prepare plant flow diagrams to reflect proposed, in-progress, and final design.

Clearances shall be provided around equipment for ease of operation and maintenance

in accordance with OSHA requirements and good engineering practices.

Prepare P&ID's showing equipment, equipment tag numbers, piping, pipe line numbers, valves, valve tag numbers, piping specials, system codes, connection numbers, heat tracing, equipment sizing/key performance, line sizes, valve sizes, material references, insulation references, instruments and controls, and conceptual control logic.

Prepare plant equipment arrangements and elevations dimensionally locating centerlines of all equipment included in the plant in all planes.

Prepare equipment installation detail drawings for all plant equipment.

Prepare piping plans, piping sections, and detailed isometric drawings showing above grade piping 2-1/2 inches in diameter and larger. Plans and sections shall include piping line tags, line sizes, and general dimensions as required to define the general location of the piping. Isometrics shall include dimensional information necessary to fabricate the piping and shall indicate pipe sizes, instrument connections, and attachments such as hangers. Isometrics shall include a detailed Bill of Material with material quantities and specifications for all materials required to fabricate the piping. Standard details shall be provided to show insulation supports and weld end preparation details. Piping 2 inches in diameter and smaller shall be shown schematically on appropriate drawings.

Design and provide schematics and plan drawings for all plant plumbing systems.

Design pipe hanger systems for piping 2-1/2 inches in diameter and larger and for pipe 2 inches and smaller that operates at greater than 250°F. The location for each hanger shall be shown on the piping drawings for space control and for coordination with other equipment and components. Provide detailed hanger design drawings indicating the hanger installation requirements and including a detailed Bill of Materials with all component specifications indicated.

Provide design engineering and prepare drawings for plant facility HVAC systems.

Provide design engineering and prepare drawings for fire protection and control systems for plant facilities.

Design all piping and equipment insulation and lagging systems.

4.1.4 Electrical Design

Prepare a complete set of plant one-line diagrams of electrical systems rated at 480 volts and higher and a complete set of three-line diagrams for the generator voltage electrical system.

Prepare reports documenting electrical system studies performed for equipment selection, grounding design, cable sizing, and protective relay settings.

Prepare conduit, cable and raceway arrangement drawings for conduit, electrical cable trays, wire ways, and underground duct banks.

Prepare grounding drawings showing grounding method and connections to all equipment and building structures.

Prepare raceway and circuit lists for electrical and instrumentation installation and termination as required for construction only.

Prepare schematic / wiring / interconnection diagrams showing schematics and terminations for cables including all external connection terminal block numbers. Wiring drawings shall include connection drawings both internal and external, NEMA Standard across-the-line industrial control schematic drawings for all control systems provided or designed by Contractor, physical location drawings for all terminal blocks, power requirements, and other related items. Final electrical drawings shall include circuit numbers, wire designations, and similar features, marked on approval drawings by Engineer. Electrical drawings made for this Project shall have NEMA Standard symbols.

Provide power and instrument transformer connection and polarity diagrams.

Provide bushing and lightning arrestor outline drawings for switchgear and surge protection equipment.

Prepare lighting and communication system drawings.

Prepare power distribution drawings.

Prepare lightning protection and cathodic protection drawings.

4.1.5 Instrumentation and Controls Design

Contractor shall:

1. Provide design engineering for fully integrated microprocessor based Distributed Control Systems (DCS) to provide control, alarm, historical data archiving and performance monitoring functions for the major plant systems. Contractor shall design and specify all plant instrumentation, control, and monitoring devices.
2. Prepare contract instrumentation Lists.
3. Prepare SAMA and ISA style logic diagrams for all control algorithms executed within the DCS.
4. Prepare control narratives to describe DCS logic on a system-by-system basis and keep updated as the control logic changes.
5. Prepare Instrument Installation Details.
6. Prepare location plans for all field devices including, but not limited to, control valves, transmitters, thermocouples, pressure and temperature gauges and flow elements.
7. Develop instrument data sheets for review and future use by Owner.
8. Design duct burner management systems including purge, burner control, and fuel safety systems.
9. Design CEMS systems as required by the project air quality permits and 40 CFR 60 and 40 CFR 75.
10. Design communications links for all FDIs (Foreign Device Interfaces) including, but not limited to, Fuel Gas Regulating Station Flow Computer, miscellaneous PLCs, and Remote Dispatching RTU.

4.2 DESIGN REVIEWS

Design Reviews shall be performed jointly by Contractor and Owner as part of the engineering execution of the work. PDS Model review will be the primary mechanism used for review of physical plant features. Design reviews will take place when engineering is about 20%, 50%, and 70% complete and appropriate HAZOP reviews will be completed as required.

4.3 DRAWING AND SPECIFICATION REQUIREMENTS

The type, preparation, approval, indexing, and distribution of drawings, specifications, and data shall be governed by this section. Drawings and specifications shall be sufficiently complete to ensure that the Project will conform fully to the requirements of these Specifications and the Contract. All final drawings and specifications shall be provided on an indexed compact disk (CD). Final as-built drawings, including OEM drawings, shall be submitted to Owner on CDs per PacifiCorp drawing standards as referenced below. All drawings shall be in the same version of the software. Contractor's specifications shall be prepared using Microsoft Word software. All drawings, including also OEM and sub-vendor system drawings, shall reference and be compatible with all interfacing drawings. Drawings (both electronic and hard copy) shall be modified to show the complete as-built facilities, including any modifications made to the facility during the warranty period resulting from defects corrected under the warranty. Quantities of copies to be provided are listed in Table 4.2-1.

All documents, drawings, and other engineering deliverables shall be provided in accordance with Appendix M - "Engineering Documents, Drawings and Other Deliverables". All drawings shall be prepared per PacifiCorp Energy's Drafting Standards and Documents (zip file entitled "PCorpThermalStandardsVendor.zip").

4.3.1 Drawing and Specification Schedule

Contractor shall submit a Drawing and Specification Schedule to the Owner for review. The Drawing and Specification Schedule shall list all drawings and specifications to be produced by Contractor and shall include, but is not limited to, the following information:

1. Schedule date for the first issue for Owner's Review.
2. Schedule date for return of Owner's Review comments.

3. Schedule date for issue for design, procurement, or construction.
4. Actual date of issue.
5. Actual revision dates.

Contractor shall revise and submit to Owner the Drawing and Specification Schedule monthly, including notation of approval dates, revisions, additions, and deletions.

4.3.2 Drawing and Specification Submittals

Contractor shall submit timely and descriptive information, which relates to the technical aspects of the Scope of Work set forth in the Contract. Such submittals shall be adequate to convey to Owner system arrangement, operating modes, output performance, emission control, selection of construction materials, and all other information as required by Owner to determine Contractor adherence to these Specifications.

Submittals shall be of suitable quality for legibility and reproduction purposes. Every line, character, and letter shall be clearly legible. All words and dimensional units shall be in the English language or in English units. Where standard documents are furnished which cover a number of variations of the general class of equipment, the document shall be annotated to clearly indicate exactly which parts of the drawing apply to the item for which the Submittal is intended. If conforming Submittals cannot be obtained, such documents shall be retraced, redrawn, or photographically restored as necessary to meet these requirements. Contractor's failure to satisfy the legibility requirements will not relieve Contractor from meeting the required schedule for submittal nor will it be cause for delay in the Project schedule.

Electronic Submittals shall be in the form of AutoCAD and either Microsoft Word or Excel, or Adobe Acrobat files. All AutoCAD files shall also be submitted as PDF files for ease of printing. Identify each Submittal by Project name and number, and indicate equipment or component tag number on each submittal drawing or document.

Owner will, by a notice to Contractor, classify the reviewed submittal to indicate the acceptance or rejection of the documents. Following are definitions of the action categories which will be used by the Owner and the associated meaning and requirements of the Contractor:

1. REVIEWED – NO COMMENT – Signifies that Equipment or Material represented by the Submittal conform to the design concept, comply with the intent of the Contract and Specifications, and are acceptable for incorporation in the Work. Contractor is to proceed with Work based upon the content of the Submittal. Final copies of the Submittal shall be transmitted to Owner as indicated below.
2. REVIEWED – NOTE COMMENTS – Signifies that Equipment or Material represented by the Submittal conform to the design concept, comply with the intent of the Contract and Specifications, and are acceptable for incorporation in the Work with Owner’s comments indicated. Contractor is to proceed with Work based upon the content of the Submittal with all comments incorporated. Contractor shall submit a revised Submittal responsive to Owner’s comments.
3. REJECTED – INADEQUATE INFORMATION – Signifies that Equipment or Material represented by the Submittal appear to conform to the design concept and appear to comply with the intent of the Contract and Specifications. However, the Submittal is lacking in adequate detail and information or contains discrepancies, which prevent Owner from completing his review. Contractor shall not proceed with Work until Owner approval is obtained. Contractor shall revise the Submittal responsive to Owner’s comments and resubmit for approval.
4. REJECTED – NOTE COMMENTS – Signifies that Equipment or Material represented by the Submittal do not conform to the design concept, do not comply with the intent of the Contract and Specifications, and are disapproved for incorporation in the Work. Contractor shall not proceed with Work until Owner approval is obtained. Contractor shall revise the Submittal responsive to Owner’s comments and resubmit for approval.
5. FOR REFERENCE, NO APPROVAL REQUIRED – Signifies the Submittals are for supplementary information only. Owner reviews such Submittals for general content, but not for substance.
6. FINAL – Signifies that Submittal has been previously approved and is being accepted as a final Submittal. Submittal is approved for incorporation by Contractor into the final project documents (O&M manuals, Technical Libraries,

etc).

In resubmitting a Submittal which has been reviewed by Owner subject to compliance with comments, or which has been disapproved by Owner, Contractor shall state the action taken on each comment by indicating in his forwarding letter that the comment has been complied with, or by explaining why the requested alternative was not made, and Contractor is proceeding at his own risk.

Resubmit Submittals the number of times required to obtain the REVIEWED – NO COMMENT action on the Submittal. Allow the Owner the time indicated above in the Drawing and Specification Schedule section for each submittal and resubmittal. The requirement for any number of resubmittals will not be grounds for an extension in Key Dates provided the Owner completes his reviews in the time frame specified.

Any resubmittal incorporating changes from the previous submittal shall have changes clearly marked or highlighted in both the hard copies and the electronic format. Any changes made to equipment or systems after receiving approval shall be indicated on the documents and the documents resubmitted for approval.

Contractor shall provide the quantities of Submittals indicated in the following and in the format indicated or in a format approved by Owner in the Project Administration Manual per 4.3.5 of this section:

DOCUMENT FORMAT & QUANTITY				
Table 4.3-1				
TYPE	ABBREVIATION	PRINTS	FTP Server	TO
Issue for Owner's Review	IOR	1	1	Owner
Issue for Information	IFI	1	1	Owner

Issue for Design	IFD	1	1	Owner
Revisions	REV	1	1	Owner
Issue for Bids	IFB	1	1	Owner
Issue for Purchase	IFP	1	1	Owner
Issue for Construction	IFC	1	1	Owner
As-Built	AB	1	3 on CD	Owner

The documents to be submitted by Contractor shall include but are not limited to the following:

Mechanical Submittals	
Table 4.3-2	
Submittal Description	Schedule
Heat and mass balances for all guarantee points and minimum and maximum site conditions at Peak Load, Base Load and Minimum Load.	IOR, IFC, REV, IFD, AB
Plant fuel consumption at guarantee points and for Peak Load, Base Load, and Minimum Load.	IOR, IFC, REV, IFD, AB
Water balances for guarantee points and minimum and maximum site conditions	IOR, IFC, REV, IFD, AB
P & Ids	IOR, IFC, REV, IFD, AB
System Descriptions	IOR, IFC, REV, AB
Equipment arrangements and locations	IOR, IFC, REV, IFD, AB
Piping Plans & Sections	IOR, IFI, IFC, REV, AB
Piping Isometrics	IFI, IFC, REV, AB
Hanger Location Drawings	IFI, IFC, REV, AB

Hanger Detail Drawings	IFI, IFC, REV, AB
Steam blow and cycle flush piping	IOR, IFC, REV
Fire system drawings	IOR, IFC, REV, AB
Piping Line List	IOR, IFC, REV, AB
Equipment list	IOR, IFC, REV, AB
HVAC layout	IOR, IFC, REV, IFD, AB
Procurement specifications	IOR, IFB, IFP, REV
Construction specifications	IOR, IFC, REV
Startup, commissioning, and test procedures	IOR, IFC, REV
All vendor drawings and submittals (P&ID's, electrical one-lines and equipment outlines for review, all other drawings for information)	IOR, IFC, REV, IFI, AB
Operation and Maintenance Manuals	IOR, IFC, REV, AB
Pipe Stress Analysis	IFI, IFC, REV
All pump characteristic curves	IFI, IFC, REV, AB
List of all Special Tools for construction and maintenance	IFI, IFC, REV
Requirements for storage and protection of equipment	IFI, IFC, REV
Valve list	IFI, IFC, REV, AB
Lubrication list	IFI, IFC, REV, AB
Chemicals and Consumables list	IFI, IFC, REV, AB

Civil Submittals	
Table 4.3-3	
Submittal Description	Schedule
Site arrangement	IOR, IFC, REV, IFD, AB
Plant arrangement	IOR, IFC, REV, IFD, AB
Access roads, curbs, parking, walkways, and fencing	IOR, IFC, REV, IFD, AB
Grading Plans and Topography	IOR, IFC, REV, IFD, AB
Evaporation Pond Design and Plans	IOR, IFC, REV, IFD, AB
Construction Drainage Plan	IOR, IFC, REV
Final Drainage Plan	IOR, IFC, REV, AB

Yard piping	IOR, IFC, REV, AB
Underground electrical duct bank	IOR, IFC, REV, AB
Site construction utilities	IFI, IFC, REV
All Site surveys	IFI, IFC, REV
Laydown and temporary facility Plans	IOR, IFC, REV
All construction specifications	IOR, IFC, REV
Geotechnical Reports	IFI, IFC, REV

Electrical Submittals	
Table 4.3-4	
Submittal Description	Schedule
Electrical Plans and Elevations	IOR, IFC, REV, AB
Conduit, cable, and raceways	IOR, IFC, REV, AB
One-Line Diagrams	IOR, IFC, REV, IFC, AB
Three-Line Diagrams (generator and auxiliary voltages only)	IOR, IFC, REV, AB
All electrical Calculations including short circuit, load flow, relay coordination studies, etc.	IOR, REV
All Lighting and Communication Drawings	IOR, IFC, REV, AB
Plant Grounding System and Lightning Protection	IFI, IFC, REV, AB
Power and Control Wiring Diagrams	IOR, IFC, REV, AB
Electrical Schematics and Connections	IFI, IFC, REV, AB
Motor List	IFI, IFC, REV
All Motor Manufacturer's Data	IFI, IFC, REV
Switchboard Panel Layout	IOR, IFC, REV
Procurement Specifications	IFB, IFP, REV
Vendor Drawings (one-line and outline drawings as well as vendor manuals for review all other for information)	IOR, IFI, REV, IFC, AB

Instrument and Controls Submittals

Table 4.3-5

Submittal Description	Schedule
Instrument list	IFI, IFC, REV, AB
Control Valve and Relief Valve Lists	IFI, IFC, REV, AB
All Procurement Specifications including data sheets for all instruments, control valves, and relief valves	IFB, IFP, REV
Control System Architecture Diagram	IFB, IOR, IFC, REV, AB
DCS Control Loops	IOR, IFC, REV, AB
Control Logic Diagrams and Control Narratives	IOR, IFC, REV, AB
Conceptual and Final Graphic Displays	IOR, IFC, REV, AB
Instrument Loop Diagrams	IFI, IFC, REV, AB
All Vendor Drawings and Data	IOR, IFC, REV
Instrument location plans	IOR, IFC, REV, AB
Instrument installation details	IOR, IFC, REV

Structural Submittals

Table 4.3-6

Submittal Description	Schedule
All Structural Steel Design Drawings	IOR, IFC, REV, AB
Foundation Location Plans and Foundation Drawings	IOR, IFC, REV, AB
All Structural Steel Fabrication Drawings	IFI, IFC, REV
All Rebar Drawings	IFI, IFC, REV
All Structural Calculations	IFI, IFC, REV
All Procurement Specifications	IFB, IFP, REV
All Construction Specifications	IOR, IFC, REV
Foundation Design Calculations	IFI, IFC, REV
All Structural Material Specifications	IFI, IFC, REV

Architectural Submittals	
Table 4.3-7	
Submittal Description	Schedule
Building Layout Drawings	IOR, IFC, REV, AB
Building Architectural Drawings	IOR, IFC, REV, AB
Building Interior and Exterior Finish Samples and Color Samples	IOR, IFC, REV
Building Technical Specifications	IOR, IFC, REV

Miscellaneous Submittals	
Table 4.3-8	
Submittal Description	Schedule
Plant Manuals	IOR, IFI, REV, AB
Manufacturers Instruction Books	IOR, IFI, REV
Start Up, Commissioning, and Test Procedures	IOR, IFI, REV
Critical Path Schedule	IOR, IFI, REV (monthly)
Project Status Reports	IOR, IFI (monthly)
Plant Administrative Manuals	IOR, IFI, REV

Distribution of drawings shall be to multiple parties as defined in the Project Administration Manual.

4.3.3 Plant Manual and Instruction Books

4.3.3.1 Plant Manual

Manufacturers instruction books shall be integrated into a single plant manual with multiple volumes and provided final on three (3) CD copies in MS Word and/or PDF format and ten (10) printed paper copies sized to fit a standard three-ring binder. All paper copies of the manual shall be thoroughly indexed and placed in high quality binders with volumes and content clearly marked on the cover and spine.

The plant manual shall contain site specific information on the plant operation. Normal operating sequences (including startup and shutdown) shall be described together with normal running inspections for all supplied equipment and systems. Troubleshooting and diagnostic recommendations shall also be included. Special notes and cautionary statements shall be included and highlighted throughout the manual to enable easy recognition of special procedures and techniques which must be followed to ensure correctness and safety for equipment and personnel. Two review copies of the manual shall be submitted for Owner review and approval 90 days before start of training and final copies shall be submitted within 30 days of receipt of Owner comments.

Plant manual shall contain the latest as-built information for the facility. Contractor shall obtain all as-built information for all vendor's equipment including Owner purchased equipment. Manuals (both hard copy and electronic) shall be updated with any modifications to equipment or systems made to the facility during the warranty period resulting from defects corrected under the warranty. Equipment, instrument, and parts lists shall be provided in Excel format (latest version). Parts list shall have been reviewed by Contractor, then submitted to Owner and reviewed and approved before initial submittal of the Plant Manual (90 days before start of training).

4.3.3.2 Manufacturer's Instruction Books

Manufacturer's instruction books shall be provided for all electrical, mechanical, hydraulic, pneumatic, and electronic equipment and instrumentation that requires explicit information and instruction for proper operation and maintenance. Instruction books shall be integrated into a plant manual as described above.

Commercial documents are acceptable to Owner, provided that the specific equipment used in the construction is clearly identified and that the following are included for all components and sub-components of a complex assembly:

1. Installation, start-up and initial test instructions.
2. Manufacturer Test Reports.
3. Start-up Test Reports.
4. Operating instructions, including safety precautions.

5. Maintenance procedures and routine adjustments.
6. Parts illustrations, including parts lists adequate for the purpose of identifying and ordering replacement parts and lists of recommended spare parts for three (3) years of operation of any given component.
7. Wiring schematics for electrical equipment.
8. Hydraulic diagrams for hydraulic equipment.
9. Detailed descriptions of the functions of each principal component of a system.
10. Performance and nameplate data.
11. Alignment instructions if required.
12. Safety precautions.
13. Maintenance and major overhaul instructions, which shall include detailed assembly drawings with parts numbers, parts lists, instructions for ordering spare parts, and complete preventative maintenance instructions required to ensure satisfactory performance and longevity of the equipment involved.
14. Lubrication instructions, which shall list points to be greased or oiled, shall recommend type, grade, and temperature range of lubricants, and shall recommend frequency of lubrication.

4.3.4 System Startup & Commissioning Test Procedures and Reports

Startup and commissioning test procedures and reports shall be prepared by Contractor for all systems in accordance with the Contract and submitted for Owner review and approval 90 days before startup and commissioning is to begin. These procedures shall identify step-by-step actions to be taken to verify that systems operate in accordance with design intent and that all protection, control, indication and alarm functions are operational. Design criteria and acceptable levels (flow, pressure, temperature, time as appropriate) shall be identified in the procedure and provisions for recording of actual criteria observed during the startup will be included. Each step upon its completion shall require a signoff of both Contractor's Test Engineer and Owner's Representative. Five (5) hard copies and three (3) CD of the test procedures and of the test results shall be

provided to Owner.

4.3.5 Project Administration Manual

Within 60 Days of notice to proceed, Contractor shall prepare and submit for approval a Project Administration Manual indicating a responsibility matrix; key Project contacts; document distributions; Project scope; Project organization; execution plan; administrative procedures; quality control procedures; Project schedule; equipment, piping, and instrument tagging procedures; design criteria; and other key Project administration functions.

4.3.6 Critical Path Schedule

Contractor shall provide to Owner and update monthly a Critical Path Schedule per the Contract. Critical Path Schedule shall satisfy the requirements set forth in the Contract.

4.3.7 Project Status Reports

Contractor shall prepare and submit to Owner monthly Project Status Reports.

4.3.8 Coordination Meetings

Representatives of Contractor shall attend coordination meetings relative to the progress and execution of this Contract. At the initial meeting, Contractor shall present a plan including, but not limited to, the following: safety, project design parameters, constraints, assumptions, sequence and methods to be used in all phases of design; and detailed Project schedule showing major activities for each system for the entire Project.

Contractor and any other parties involved in the construction of the Project shall attend such pre-construction meetings as may be requested by Owner. At the initial meeting, Contractor shall present a construction plan including, but not limited to, the following: safety, procurement plan, major equipment receipt plan, construction sequence, methods and equipment to be used in all phases, tentative access and right-of-way roads, locations of staging areas, regrading of roads, moving of equipment/property that will interfere or impact construction and a construction schedule showing all activities for the entire construction phase of the Project.

Contractor shall be responsible for contacting all involved utility companies prior to starting any work to determine schedule of work and location of all temporary and permanent facilities in the Project area.

Contractor shall prepare an outage plan for all scheduled interruptions of electrical power or other utilities interference that would affect the Currant Creek operating plant. This plan shall be submitted by Contractor to Owner for approval at least 30 days prior to outage. The plan shall include all reasonable efforts shall be taken to minimize impact on existing operations including sequencing of work to minimize outage time and work during off peak hours such as night and weekends.

Representatives of Contractor shall attend weekly coordination meetings to discuss matters relative to the progress and execution of the construction and startup of the Project. Current week progress and three-week look ahead schedules shall be presented by the Contractor and reviewed at these meetings in addition to other Site coordination items.

4.3.9 Contractor Acquired Permits

Contractor shall provide Owner three (3) copies of all Contractor Acquired Permit applications as they are being submitted to the responsible agency. Contractor shall provide Owner two (2) copies of all issued Contractor Acquired Permits upon approval from the responsible agency.

4.4 QUALITY ASSURANCE

Provide all equipment and products conforming to applicable Specifications, codes, standards, and requirements of regulatory agencies.

Design, fabricate, and assemble in accordance with the best engineering and shop practices.

Owner and Owner's representative shall have the right to inspect equipment and work at any time or place.

Contractor shall furnish all factory and field test procedures and reports to Owner for information.

At Owner's request, Contractor shall make available all manufacturers quality control documentation.

Contractor shall notify Owner of all Witness Tests at least two weeks in advance of such

tests. Owner or Owner's representative may choose to witness test at no additional cost or schedule impact. Contractor shall provide list and schedule of Witness Tests to Owner for review

SECTION 5.0 MECHANICAL SCOPE

5.1 GENERAL REQUIREMENTS

This section provides requirements for major mechanical equipment, mechanical systems, and mechanical interfaces with other plant systems and off-Site facilities.

5.1.1 General Sizing Criteria

All mechanical equipment and systems shall be designed to continuously operate in a stable manner at all operating conditions from Peak Load to Minimum Load including full STG bypass mode. Mechanical equipment, systems, and piping shall be sized based on the operating performance parameters (pressure, temperature, flow rate, and the like) contained in Contractor's heat balances. Contractor shall evaluate the Project for the full range of operating loads including Peak Load, Base Load, and Minimum Load at the full range of design ambient conditions to determine the equipment and system sizing criteria. Contractor shall evaluate and define transient operating conditions (ie. startup, shut down and plant trip scenarios) in design of mechanical systems.

All equipment shall have sufficient design margins based upon good engineering practice. Following is a listing of the minimum design margins for select equipment and systems that shall be applied to the sizing criteria conditions (flow, head, duty, and the like):

Equipment / System	Minimum Design Margin
General Service Pump	10% flow, 5% head
Condensate Pumps	5% flow, 10% head
Boiler Feed Pumps	5% flow, 5% head
Closed Cooling Water Pumps	10% flow, 5% head
Fuel Gas Supply	5% flow at lowest anticipated heating value and pressure.

Line sizes and equipment capacities shall be determined based on flow rates and the specific performance criteria for each system. All sizing values (flow, horsepower, temperature, pressure, diameter, etc.) contained in these Technical Specifications and Conceptual Design Documents contained in Appendices B through E are preliminary. Contractor shall be responsible for final sizing and providing all mechanical equipment, systems, and piping to meet all requirements specified herein.

5.1.2 Piping

Contractor shall size lines to provide fluid velocities that are in accordance with good engineering practice. Table 5-1 shows maximum pipeline velocity guidelines that shall not be exceeded without Owner's approval. The final selection and specification of piping materials shall be suitable for long term durability and shall satisfy all system design and code requirements.

Table 5-1

MAXIMUM PIPELINE VELOCITIES – FEET PER SECOND

Diameter Inches	Super-heated Steam	Saturated Steam > 25 psig	Saturated Steam <25 psig	Compress Air/Gases	Boiler Feed Suction	Boiler Feed Discharge	Condensate Pump Discharge	General Water Pump Discharge	General Water Pump Suction
1	110	100	65	30	3	8	-	4	3
1-1/2	130	110	70	35	3	8	-	4	3
2	150	120	75	40	4	8	8	5	4
4	200	140	85	50	4	12	8	6	5
6	230	150	95	60	4	14	8	8	5
8	250	160	100	60	4	17	10	9	5
10	250	160	100	60	4	18	10	9	5
12	250	160	100	60	4	20	10	10	5
16	250	160	100	60	4	25	10	10	5
20	250	160	100	60	4	25	10	10	5
24	250	160	100	60	4	25	10	10	5
30	250	160	100	60	4	25	10	10	5
36 & Larger	250	160	100	60	4	25	10	10	5

*Actual pipeline velocities shall be less than those specified and shall be selected by the Contractor based on the specific system design conditions and sound engineering practice.

5.1.3 General Arrangements

The location of equipment and valves, and routing of pipe shall be based on safety, economics, ease of maintenance, and operation. Sufficient space shall be provided for maintenance of all equipment including equipment removal without excessive rigging or removal of surrounding equipment, piping, and valves. Where possible, locate valves to be safely accessible from walkways, accessways, or platforms.

5.1.4 Platforms

Provide platforms to access equipment, instruments, engineered valves, start-up vent and drain valves, and other components requiring access for periodic maintenance, start-up, or operation. Provide stair access to maintenance areas that require bulky or heavy tools.

Review Gas Turbine-Generators, Steam Turbine Generator, HRSGs, and Air Cooled Condenser layouts to provide additional access as required to comply with the Manufacturers requirements.

The following paragraphs define the general requirements of where platforms shall be provided. Design and construction requirements for platforms are defined in the Structural and Architectural Scope section.

Provide platforms as required in the following to access elevated components not accessible from grade, unless specified otherwise:

1. Class 1 Areas – Regularly attended areas for daily or weekly lubrication, start-up, operation, inspection, observation, or maintenance.
 - A. Provide platforms a minimum of 3 feet wide, clear of all obstructions with length as required (minimum 4 feet)
 - B. Provide stairs to access the platforms
 - C. Provide emergency escape ladders for platforms as required by OSHA for platforms having dead ends.

2. Class 2 Areas – Maintenance areas requiring access monthly or annually for lubrication, repair, inspection, calibration, or maintenance.
 - A. Platforms shall be adequately sized to allow two men to work simultaneously with tools and equipment internals (minimum of 20 square feet – 4 feet x 5 feet)
 - B. Platforms shall be accessible by stair or ladder. Areas requiring maintenance with heavy or bulky tools (heavier than 25 lbs) shall be provided with stair access.

As a minimum, areas requiring access as defined above shall include, but not be limited to, the following:

3. Class 1 Areas:
 - A. HRSG steam drums and associated level gauges and instrumentation
 - B. HRSG, STG, GTG, and other equipment observation ports
 - C. Gas turbine borescope inspection ports
 - D. Internal and external platforms to provide access to all doors and maintenance access panels provide by GTG manufacturer
 - E. Steam turbine operating deck
 - F. GTG CEMS ports on HRSG casing (also ductburners, NH₃ injection, etc)
4. Class 2 Areas:
 - A. Calibrated instruments including block valves necessary to isolate the instruments for safe routine maintenance and calibration.
 - B. Steam turbine bypass and desuperheating valves
 - C. Stack CEM port and sample ports
 - D. GTG inlet filter plenums
 - E. HRSG sample ports
 - F. Pressure indicators and gauges
 - G. Pressure safety valves
 - H. Sample ports
 - I. Control valves

- J. Elevated equipment manholes
- K. Motor operated Isolation Valves
- L. Air actuated isolation valves
- M. Top manholes and gauging wells on large tanks
- N. Relief valves and instrument on top of the ammonia storage tanks
- O. Top of field erected tanks (provide a ladder).

Provide a 3-foot minimum wide, continuous catwalk platform on the steam pipe rack. Platform shall extend between the HRSGs to provide access between the HRSG platforms and between the inner most HRSG and the steam turbine deck to provide access from the HRSG platforms to the steam turbine deck. Pipe Rack catwalk shall be accessible from each HRSG and the STG without descending to grade.

5.1.5 Accessways and Clearances

Contractor shall finalize the maintenance laydown areas, show them on general arrangement drawings, and obtain the Owner’s approval of the general arrangements prior to detailed design.

Contractor shall provide an area to pull the generator rotor on the steam turbine operating level. The pull area shall have a strong back.

5.1.5.1 Horizontal Clearances (Minimum):

Horizontal clearances (clear of all piping and accessories) shall be maintained as follows (unless approved otherwise by Owner):

- | | |
|--|---------|
| 1. Crane Accessways | 25'- 0" |
| 2. Fork Truck / Pick-up Truck Accessways | 15'- 0" |
| 3. Operating Aisles | 4'- 0" |
| 4. Elevated Maintenance Platforms | 3'- 0" |
| 5. All Around Pumps & Blowers | 3'- 0" |
| 6. All Around Boiler Feed Pumps | 5'- 0" |
| 7. All Around Heat Exchangers | 3'- 0" |
| 8. All Around Tanks | 5'- 0" |

- | | |
|---|--------|
| 9. Around other Major Equipment | 5'- 0" |
| 10. One Side of Control Valve Stations | 3'- 0" |
| 11. Back Side of Control Valve Stations | 1'- 6" |

Provide fork truck / pick-up truck aisles on access side of all equipment with motors, large manholes, or endplates and next to all equipment requiring chemical addition or replacement of totes.

5.1.5.2 Vertical Clearances (Minimum):

Overhead clearances (clear of all piping and accessories) shall be maintained as follows (unless approved otherwise by Owner):

- | | |
|---|---|
| 1. In buildings | 7'- 6" |
| 2. Normal operating or maintenance access areas | 8'- 0" |
| 3. Elevated Platforms | 7'- 6" |
| 4. Control Valves | As required to remove actuator and pilot
(12-inch minimum) |
| 5. Plant access & maintenance roads & crane | 16'- 0" Accessways |
| 6. Railroad crossings | 25'- 0" above the top of the rails |

5.2 MECHANICAL SYSTEMS AND EQUIPMENT

5.2.1 General

Provisions shall be included in the design of all mechanical systems to allow the performance of all routine maintenance without requiring a plant shut down. Provisions shall include but not be limited to redundant equipment, isolation valves, and access spaces.

Contractor shall:

1. Receive, inspect, store, unload, erect, clean, lubricate, align, and prepare all equipment in accordance with equipment manufacturer's instructions before initial operation.
2. Provide lifting lugs on all equipment components or system components requiring removal for maintenance and weighing over 25 lbs.

3. Provide OSHA approved guards on all rotating components.
4. Select materials of construction and design equipment and systems to provide a minimum of a 30-year operating life at all operating conditions specified.
5. Provide major system components designed for a 30-year life without the need for major repairs or replacement. Only routine maintenance items (i.e. belts, couplings, bearings, seals, pump impellers, and the like) shall require replacement at increased frequencies.
6. Provide grounding lugs and ground all equipment and structural components.
7. Care shall be taken to assured that piping connections are made to equipment and machinery so that no reactions or moments in excess of those allowed by the manufacturer are imposed during installation, test, or operation.
8. Provide access doors on equipment and systems as required to adequately clean, inspect, and maintain all system components. In general, access doors shall be bolted and sealed. Access doors over 25 lbs. shall be hinged or supplied with a davit.
9. Extend all grease or lubrication lines for equipment or instruments to be accessible from grade or operating platforms.
10. Provide actuators on all start-up drain and vent valves on the steam turbine, HRSG, steam piping, and boiler feed pump, and elsewhere to enable remote start-up and shutdown of the units.

5.2.2 Pumps - General

General service pumps shall be designed and fabricated in accordance with the recommendations of the Hydraulic Institute and be suitable for the service. All end suction pumps shall be in accordance with ANSI standards.

Horizontal pumps shall have motor and pump mounted on a common baseplate and connected with a flexible spacer coupling and non-sparking coupling guard. Baseplate shall include a containment rim to contain 115% of the maximum amount of lubricant contained in the pump. Provide a drain valve and plug on the baseplate.

All pumps shall be supplied with mechanical seals designed for the service. Similar

parts of duplicate pumps shall be completely interchangeable. Equipment and piping arrangement, and nozzle orientation, shall be selected for ease of maintenance and to minimize the dismantling or removal of piping and electrical connections for maintenance.

Supplied impeller on all pumps except the boiler feedwater pumps shall be a minimum of ½-inch smaller than the maximum impeller for the pump casing.

Pump head curves shall rise continuously from design head to shut-off head. Shut-off head for Boiler Feed Pumps shall be a minimum of 115% of the rated head at design condition and a maximum of 130% of rated head at design condition. Shut-off head of all other pumps shall be a minimum of 115% of the rated head at design condition and a maximum of 150% of rated head at design condition. For condensate and boiler feed pumps, maximum shut-off head shall be 140% of rated head at design condition.

Pumps shall operate at the left of the best efficiency point at design conditions.

Motors shall be sized for end of curve conditions for supplied impeller. Motor service factor may be used in determining motor size for end of curve conditions. Motor service factor shall not be used in selecting motor for operating or rated conditions.

Select pumps for operating speeds of 1800 rpm. Where 1800 rpm pumps will not meet the required head, 3600-rpm pumps shall be used. Pumps shall be subject to shop inspection and manufacturer's standard shop tests.

5.2.3 Tanks and Vessels - General

Two new 300,000 gallon Fire Water Storage Tank shall be added for serving Block 1 and Block 2. The existing Raw Water/Fire Water Storage Tank shall be converted for just raw water use. The contractor shall ensure that NFPA and local fire protection recommendations and requirements are met.

One new 200,000 gallon Demineralized Water Storage Tank shall be provided. The new and existing Demineralized Water Storage Tanks shall be common to both Block 1 and Block 2.

Field erected tanks shall be designed, fabricated, inspected, examined, and tested in

accordance with API 650 or AWWA Standard D-100.

All roof seam seams shall be fully seal welded. Roof seams on demineralized water tanks shall be butt joints. Interior welds on demineralized water tanks shall be ground smooth. The tank exterior and interior shall be protected with a suitable lining or coating material.

Tanks and vessels with a design pressure over 15 psig shall be designed, fabricated, inspected, examined, tested and stamped in accordance with ASME Section VIII, Division I, Boiler and Pressure Vessel Code.

Water storage tanks shall be lined or coated on the inside and outside for corrosion protection. Lining and coatings selected shall be suitable for the intended service. Linings and coatings shall be applied in accordance with coating manufacturer's recommendations. Condensate Receiver Tank shall be insulated.

Tank and vessel construction materials shall be selected for the intended service to minimize corrosion and provide an extended life as defined for the plant. Provide a minimum corrosion allowance of 1/16-inch on all carbon steel tanks and vessels.

Contractor shall:

1. Provide cathodic protection for all tanks and vessels as recommended by a corrosion engineer after reviewing soils conditions for the Site. Obtain Owner's approval of cathodic protection design prior to executing work. Block 2 Cathodic Protection System shall be compatible with the existing plant cathodic protection system.
2. Provide a minimum of two manways on each field-erected tank. Manways shall have a minimum opening size of 30 inches diameter. One manway shall be located on the side of the tank or vessel and shall be accessible from grade. The other shall be accessible from the top of the tank or vessel. Provide supports, gaskets, belts, vents, standpipes, interior and exterior piping, overflows, wear plates, nozzles, piping connections, level gauges,

platforms, stairs, walkways, and an exterior stairway and landing platform with handrails for access to the top of each tank.

3. Provide one manway with a 24-inch minimum opening for shop-fabricated tanks or vessels that are over 36 inches in diameter. Smaller vessels shall be provided with two 6-inch diameter hand holes. Provide a ladder to access the top of all tanks over 10 feet high.

Tank level gages shall be clearly visible from the tank loading area.

5.2.4 Heat Exchangers - General

Shell and tube heat exchangers shall be designed, fabricated, inspected, examined, tested and stamped in accordance with ASME Section VIII, Division I and TEMA, Class C. Shell and tube heat exchangers shall be supplied with flanged channels and flanged channel covers to facilitate access to both the shell and the tube sides for maintenance and cleaning. Provide valved shell and tube-side vents and drains on each exchanger. Provide double-groove, rolled tubes on all heat exchangers.

Plate and frame heat exchangers shall be designed, fabricated, inspected, examined, tested and stamped in accordance with ASME Section VIII. Plate exchangers shall be of the removable plate design and shall be provided with a frame and rollers to support the backplate during plate removal. Frames shall be sized to allow the addition of a minimum of 50% more plates.

Carbon steel components on heat exchangers shall be supplied with a 1/16-inch minimum corrosion allowance. Heat exchangers shall not contain copper.

5.2.5 Gas Turbine Generator (GTG) System

General: Contractor shall provide two (2) GE 7FA/2.6DLN or two (2) Siemens-Westinghouse SGT65000F (FD3 or FD4) or Mitsubishi M501F combustion turbines for combined cycle operation including all materials, services, and required labor necessary for a complete functional installation including all requirements for startup and testing.

Gas turbines must meet all latest TIL/Service Bulletins relating to product reliability, design or manufacturing defects as implement on currently manufactured or shipped by the OEM. Equivalent starts penalty factor for trips from load (75% or greater) shall be eight (8) or less.

The equipment shall be designed and manufactured for the application at the specified conditions without overstressing any components. The unit shall be designed to automatically maintain itself in a standby condition ready for immediate operation at all times. Contractor shall provide all necessary connections for measuring pressure drop across filters, compressor pressure ratio, turbine exhaust pressure and temperature, inlet air temperature, inlet pressure drop and turbine firing temperature. All control signals shall have a range of 4-20 mA unless specified otherwise.

Performance Guarantees: All ratings and guarantees shall be made without tolerances. New condition shall be considered to be the condition of the machine immediately after installation and less than 200 actual fired hours.

Capacity of Unit: The gas turbine-generator unit base net output capacity at the ambient conditions specified after unit auxiliary power is deducted from gross output. The capacity, defined as "base rating" shall be that load obtained at the specified ambient conditions and operated at a Turbine Inlet Temperature level consistent with maximum achievement of anticipated parts life. Provide performance correction curves with the Proposal which plot the effect back pressure, barometric pressure steam or water injection, gas turbine inlet air temperature, inlet air pressure drop, and relative humidity on turbine-generator output, air flow, heat rate, and exhaust temperature. These correction curves will be used for performance testing correction to guarantee conditions.

Fuel: Gas turbine-generator units shall be designed to operate satisfactorily at all loads when firing natural gas. See Appendix J for Fuel Gas analysis information.

Combustion System: CTGs shall be provided with dry low NO_x burners. System shall include thermal barrier coated liners, transition pieces, flame detectors, and a dynamic combustion monitoring system.

Sound Criteria: Contractor shall guarantee noise limits per Section 1.

Exhaust Emissions: Contractor shall submit with the Proposal a statement of guarantee that the gas turbine unit and auxiliaries are designed and constructed to operate in compliance with the aforementioned standards.

Evaporative Air Cooler: Shall be 85% effective and designed to work in conjunction with an inlet air filtration system. A Conductivity Control System shall be provided.

Control of Unit: Each GTG shall be supplied with a dedicated turbine control system. The turbine control system contains the unit metering, protection, and control logic required for safe and reliable turbine operation. Standard control of each gas turbine generator, as provided by the manufacturer, shall be from each respective supplied local station and from a common remote station. Remote operator station shall have identical hardware and software as the local operator station and shall also be equipped with multiunit capability to allow for the control and operation of each turbine. In addition, to being designed for starting from the local station located in a control enclosure adjacent to each unit, and remotely from a common remote control station, the unit shall be designed for starting remotely through the DCS. A command to "start" the unit from either the local or remote control station or the DCS shall initiate the automatic start-up sequence to start unit, bring the unit up to speed, synchronize, and pick up a preset minimum load. Controls shall be designed to integrate the starting and stopping of any fuel gas compressor into the automatic start-up and shutdown sequence, if a compressor is required. Controls shall be designed so unit can be loaded from the local or remote station, or DCS. When unit is on-the-line, the following functions may be performed from the local or remote station, or DCS:

- Manual load (governor) control
- Manual voltage (excitation) control
- Manual stopping of unit

Operation of the manual "stop" switch on the local or remote station or remote DCS shall initiate the automatic shutdown sequence to safely shutdown the unit. The unit shall be

automatically shut down in a safe manner in the event of abnormal, injurious, or faulted condition in any part of the gas turbine-generator unit, or its associated mechanical and electrical auxiliary equipment, either during start-up or during "on-line" operation. Unit shall be designed for complete remote and automatic operation. Each condition preventing operation or causing shutdown of unit shall be specifically identified by an alarm on the local, remote control station and DCS. Shutdown sequence shall be complete, including reset ready for automatic restarting. The turbine control system shall include provisions for HRSG interlocks. Provide variable inlet guide vanes on compressor inlet. Guide vanes shall be automatically controlled. Provide vane position indication at both local and remote control stations. Additional turbine control description is provided in SECTION 5.2.5.19. Additional interface description to the DCS is provided in SECTION 9.

Start-Up of Unit: Starting sequence for the unit shall be interlocked to prevent operation when conditions are not normal in all parts of the unit for satisfactory and safe operation. Upon actuation of the unit, start control from the control board or remotely:

1. Gas turbine auxiliaries are automatically energized in correct sequence.
2. If there are no malfunctions of the auxiliaries, the turbine is brought up to speed; otherwise the equipment is automatically shutdown, and an alarm is transmitted to the local control, remote control and the DCS.
3. Automatic governor and excitation control establishes the generated voltage at correct potential and frequency for synchronizing.
4. The equipment furnished shall assure that the generator voltage matches the bus voltage within limits safe to the equipment, with the bus voltage level within $\pm 5\%$ of set point.
5. Generator breaker shall close automatically under control of automatic synchronizing equipment.
6. Provide selection locally at unit for synchronizing automatically or manually by synchroscope and remotely from the remote station.
7. Upon automatic closure of the generator breaker, the unit shall load to a preset value.

5.2.5.1 Gas Turbine and Accessories

Summary: Gas Turbine-Generator unit shall be a gas turbine mechanically coupled to the electrical generator. Gas turbine-generator unit shall be a factory-assembled "package type" designed for automatic operation and shall be manufacturer's standard design as far as is consistent with the intent of these specifications.

Applicable Codes and Standards: Design, fabricate, assemble, install, and test equipment so that when operated in accordance with manufacturer's recommended procedures, it will conform to the applicable provisions of, but not limited to, the following standards:

1. National Electrical Manufacturers Association (NEMA):
SM33 - Gas Turbine Sound
2. American Society for Mechanical Engineers (ASME):
Boiler and Pressure Vessel Code for Unfired Pressure Vessels
B31.1 - Code for Pressure Piping
3. American Society for Testing and Materials (ASTM):
A53 - Welded and Seamless Steel Pipe
A312 - Seamless and Welded Austenitic Stainless Steel Pipe
4. Society for Protective Coatings (SSPC) Surface Preparation Specifications:
SP-10 - Near-White Blast Cleaning: At least 95% of every 9 square inches shall be free of visible residues
SP-11 - Power Tool Cleaning to Bare Metal

Factory Tests:

All standard factory tests on equipment and all tests required by the applicable codes shall be made including:

1. Rotor overspeed test at not less than 110% speed.
2. Vibration and mechanical balance of assembled rotating parts.
3. Lubricating system tests including hot oil flushing and bearing inspection.
4. Comprehensive tests of all systems and controls to assure proper assembly and connection, including simulation tests of all safety devices.

5. Hot oil flushing of all hydraulic and liquid fuel piping.

Notify Owner when factory tests are to be made so that they may have a representative witness the tests, if desired.

Submit certificate of completion of all other tests in triplicate.

5.2.5.2 Prime Mover

The prime mover shall consist of a gas turbine provided with all standard and special accessories as specified and as required for this application.

Gas turbines shall be designed to allow continuous operation.

Compressor inlet equipment shall include air ducting with inlet filters, expansion joints, and transition sections as required, complete with airtight hinged access doors. Modulating Inlet Guide Vanes (IGV) shall be included to control air-flows during start-up for protection against compressor surge and for improved part load performance during combined cycle operation.

The gas turbine ignition system shall be automatic. The ignition system shall provide for 100% backup, and the unit shall be capable of successful starts with 1/2 of the ignition system out of operation.

Gas turbine compressed air system shall be provided as required for blade cooling, seals, complete with instrumentation and alarms.

Main reduction gear shall be designed to conform to AGMA standards for service and application.

Frame-type industrial gas turbines shall be provided with a turning gear to prevent adverse deflections of the shaft during the cooling-off period following shutdown. Turning gear and lift oil shall be fed from the essential services supply.

Provide cooling air if required to maintain proper turbine temperatures.

5.2.5.3 Governing System

Provide speed governing system including:

1. Speed governor on output shaft or shafts.
2. Fuel control mechanism.
3. Speed changer with provisions for remote adjustment.
4. Minimum fuel limiter.

Provide adjustable load limiter.

Provide fuel control systems, including control valves.

Provide temperature control system, including the following:

1. Temperature detectors.
2. Load limiting controls based on exhaust temperature.
3. Load limiting selector switch for selection of base or peak mode of operation.

Provide overspeed and over-temperature system, including the following:

1. Overspeed governor on turbine shaft.
2. Over-temperature detection.
3. Necessary protection equipment.
4. Fuel stop valves.

5.2.5.4 Fuel System

Provide fuel system complete and ready for operation, including the following:

1. All necessary control, trip, and stop valves.
2. Stainless steel gas piping.
3. Fuel strainers and dual filters with provisions to change filters under load.
Provide differential pressure gauges for all strainers and filters.

4. Gas flowmeters with $\pm 1\%$ system accuracy for the design fuel to measure net fuel consumed. Supply meters complete with totalizer and other accessories as required to be incorporated into the manufacturer's normal unit control systems. Meter shall supply compensated electrical output proportional to flow.
5. Flowmeters shall meet accuracy requirements of CEMS / permit as a minimum.
6. Pressure switches, pressure gauges, and thermometers.
7. Electric heaters, insulation, and lagging as required.

5.2.5.5 Water/Steam Injection System

Provide water or steam injection system complete and ready for operation for power augmentation, including the following:

1. All necessary control, trip, stop, and check valves
2. Water inlet strainer with five-micron filter elements. Two 100% capacity strainers with on-line manual switching shall be provided. Differential gauges and transmitters shall be included.
3. Water injection pumps, motor driven. Provide two 100% pumps where 100% is defined as the flow for NOx control or power augmentation flow whichever is greater. This will allow for one spare pump to be available when the gas turbine is operating in power augmentation mode.
4. Water injection manifolds and nozzles as required
5. Flowmeters to measure net water consumption for both emission control and power augmentation
6. Pressure gauges, pressure switches, thermometers
7. Water flow control and water injection system monitoring devices provided with data acquisition and storage
8. Relief valves
9. Recirculation valves and/or orifices, if required
10. Unit heaters and ventilation equipment, as required
11. Electrical heaters, heat tracing, insulation, and lagging as required
12. Turbine control system shall command injection water supply pumps which feed water to the turbine injection skid to start at the proper time in the engine

starting sequence

Provide water or steam injection system with all required equipment, controls, wiring, piping, and valves to automatically supply injection water to the gas turbine at the proper pressure and in the required quantities.

5.2.5.6 Lubricating Oil System

Provide oil reservoirs and dual, full flow filters with replaceable-type cartridges.

Provide dual plate and frame type lube oil coolers with stainless steel plates.

Lube oil coolers and filters shall have ASME code stamp.

Provide all valves and controls necessary to regulate cooling water flow to maintain proper lube oil temperatures. Cooling water from the plant system will be used.

Provide complete lubricating oil system including the following:

1. AC Motor driven lube oil pumps
2. AC motor driven auxiliary standby lube oil pump
3. DC emergency bearing oil pump for safe shutdown of unit in the event of an AC power failure
4. Oil reservoir heaters with thermostatic controllers designed for -20°F
5. Oil piping, valves, instruments, and controls including connections to reservoir and cooling system. Lube oil supply piping shall be 304L stainless steel. Lube oil drain piping shall be carbon steel. Lube oil system valves shall have stainless steel trim.
6. Lube vent demister for mist elimination
7. Dial-type thermometers to indicate oil supply and return temperatures
8. Valves, controls, and indicating instruments as required

5.2.5.7 Starting System

Provide complete starting system capable of starting the unit over the range of ambient conditions specified.

Starting system shall be of the electric motor or use of generator as a motor to start unit is also acceptable.

Electric motor starting system shall include the following:

1. Electric starting motor sized to start the unit without exceeding nameplate horsepower rating.
2. Torque converter, couplings, and clutch.
3. All required controls.
4. Cooling system.

If generator is used as motor to start unit, provide all transformers, controls and interlocks necessary to provide for safe start-up of turbine.

5.2.5.8 Special Tools

Provide one set of any special lifting slings or fixtures required for routine inspections, hot gas path inspections, and major overhauls.

Provide one set of all special wrenches and tools required for maintenance.

5.2.5.9 Inlet Air Filter

Provide self cleaning inlet air filtration system, complete with filter housing and all required ductwork to install inlet air filter.

Arrangement shall be up and forward inlet system arrangement.

Face velocity at inlets shall not exceed 600 fpm.

Provide severe duty filter media (high humidity / corrosive environments).

Housing and ductwork shall be steel with hinged access doors. Provide caged ladder access to inlet filter compartment, electric hoist with 500 lb lift capacity, and inlet filter compartment interior lighting.

Provide dust collection kit under each module.

Provide Air Processing Unit (APU) for filter cleaning. Include APU heat tracing kit.

Provide inlet system differential pressure indicator and transducer to measure pressure drop across filtration system and provide an alarm to indicate dirty filters and initiate the self cleaning cycle.

Provide frost point detector with icing alarm.

Provide steel inlet louver complete with stainless steel bird screen over inlet and stainless steel inlet silencing perforated sheet.

Inlet ducting shall include inlet silencing, expansion joint, 90 degree elbow, transition piece, compressor inlet humidity sensor, and compressor inlet temperature thermocouple.

5.2.5.10 Exhaust Connection

Gas turbine shall be provided with an axial exhaust connection.

Provide expansion joint to minimize loads on turbine from ductwork expansion. Expansion joint shall be designed for axial, lateral, or angular displacements. Expansion joint material shall be suitable for use with gas turbine exhaust temperature.

Exhaust system shall be carbon steel shell and stiffeners with stainless steel internal lagging.

5.2.5.11 Bypass Stack

No bypass stack shall be provided.

5.2.5.12 Water Wash System

Provide water and/or solvent wash system complete with all piping, valves, pumps, motors, tanks, including freeze protection, and controls.

System shall be skid mounted and enclosed. System shall allow washing of compressor while turbine is either on- or off-line. Each wash skid shall service two gas turbines.

5.2.5.13 Insulation

Furnish and install all required thermal insulation including insulation for compressor, combustion chambers, turbine casing, exhaust ducts and hoods, piping, oil tanks, and as required for personnel safety. Include lagging if insulation is exposed.

Thermal insulation shall be designed so that outside surface temperature of lagging will not exceed ambient air temperature by more than 10°C when gas turbine is operating.

All insulation materials shall be asbestos-free.

5.2.5.14 Sound Control Equipment

Silencers and sound control equipment shall be designed and applied as required to attenuate all noise generating sources in the gas turbine generator unit, compressor inlet equipment, gas turbine exhaust equipment, and all auxiliaries as required to meet the guaranteed silencing criteria.

Silencers shall be durable construction with sound-absorbing media encased behind perforated panels of type of metal required for a service life equal to the normal design life of the facility.

5.2.5.15 Maintenance Access

Submittals shall include adequate data to determine size of crane required and access space required for crane.

Enclosure shall include provisions for the removal of components of the engine for maintenance with welding. Provisions at roof joints shall be made to prevent the entry of wind driven rain.

5.2.5.16 Fire Protection System

Provide fire detection system and fire protection system for turbine and accessory

compartments and enclosures, including low pressure carbon dioxide supply system. Provide compartment warning signs and compartment exterior alarms.

Provide fire detectors to trip the unit, actuate the fire protection system, stop ventilating fans, close ventilating louvers, and alert the operator.

System shall be of the prolonged-discharge type designed to provide proper concentrations in each protected area. Storage system shall be sized for two discharges.

Perform an acceptance test of system to verify proper operation and concentration during commissioning. Recharge all cylinders or tanks after test.

Provide hazardous atmosphere detectors and readouts for ammonia and hydrogen.

5.2.5.17 Vibration Monitoring Equipment

BFP shall be equipped with Bentley Nevada Vibration Monitoring Control monitoring systems. This system shall be tie to Block 1 main Bentley Nevada Vibration Monitoring System. Display data on both local and remote control station and the DCS.

5.2.5.18 Painting

Turbine-generator and appurtenances shall be surface cleaned to SSPC-SP10 with profile depth of 1.5 mils, and factory prime painted with one coat of inorganic zinc primer to a dry film thickness of 2.5 mils.

Turbine-generator and appurtenances shall be field painted with one coat of polyamide epoxy as follows:

1. Thoroughly clean all surfaces to be painted. Prepare uncoated and damaged coating areas to SSPC-11 quality.
2. Apply one coat of the same primer applied in the factory on all areas where shop coat has been damaged or areas which are uncoated.
3. Apply one finish coat with a minimum dry film thickness of 5.0 mils.

Colors will be selected from manufacturer's standard colors by Owner.

5.2.5.19 Gas Turbine – Electrical and Controls

General: Electrical equipment and controls shall be manufacturer's standard pre-engineered package and shall include all special and optional accessories required for the application.

Logic apparatus for automatic control of starting, operation, and shutdown of the gas turbine unit and gas compressors shall be microprocessor based system with communication links for interconnection with other gas turbine control systems and plant DCS. Communication links shall be redundant.

Electrical equipment and controls shall include all equipment required for operation of appurtenances furnished, other specified devices, and all safety equipment required for automatic shutdown of the plant in event of malfunction.

Factory fabricate and completely assemble and wire circuit breakers and switchgear at Contractor's manufacturing location. No welding shall be required to complete field assembly of these items. Pre-engineered enclosure shall include redundant air-conditioning.

Electrical equipment shall include the following:

1. Auxiliary switchgear, motor control centers and power panels as required.
2. 125Vdc power panel for dc controls, emergency motor power, and dc motor controls.
3. 125Vdc battery of capacity required for unit.
4. Local turbine and generator control boards.
5. Excitation equipment and controls.
6. Motors as required to run necessary auxiliary equipment.
7. Provision for remote control capability.
8. Complete logic control system for starting, synchronizing, shutdown, and protection of the unit (including gas compressors).

9. Protective relays for generator.
10. Generator surge protection equipment.
11. Redundant battery chargers.
12. Static or rotary inverter equipment, if required, for ac control power for emergency shutdown conditions.
13. Other equipment as required for application.
14. A manual transfer arrangement for the 480V power supply interlocked to prevent paralleling the unit supply and the standby supply.

References:

Institute of Electrical and Electronics Engineers (IEEE):

1. No. 21 - Outdoor Apparatus Bushings, General Requirements and Test Procedures.
2. No. 32 - Neutral Grounding Devices.
3. No. 24 - Electrical, Dimensional and Related Requirements for Outdoor Apparatus Bushings.

American National Standards Institute (ANSI):

1. C37.04 - Rating Structure for ac High-Voltage Circuit Breakers Rated on a Symmetrical Current Basis.
2. C37.06a - Schedules of Preferred Ratings and Related Required Capabilities for ac High Voltage Circuit Breakers Rated on a Symmetrical Current Basis.
3. C37.09 - Test Code for Power Circuit Breakers Rated on a Symmetrical Current Basis.
4. C37.11 - Power Circuit Breaker Control.
5. C37.13 - Low-Voltage ac Power Circuit Breakers Used in Enclosures.
6. C37.16 - Preferred Ratings Related Requirements and Application Recommendations for Low-Voltage Power Circuit Breakers and ac Power Circuit Protectors.
7. C37.17 - Trip Devices for ac and General-Purpose dc Low-Voltage Power Circuit Breakers.
8. C37.20 - Switchgear Assemblies Including Metal-Enclosed Bus.
9. C37.90 - Relays and Relay Systems Associated with Electric Power Apparatus.

10. C37.100 - Definitions for Power Switchgear.
11. C57.12.00 - General Requirements for Liquid Immersed Distribution, Power, and Regulating Transformers.
12. C57.12.10 - Requirements for Transformers 230,000V and below 833/958 through 8,333 / 10,417 kVA, single phase, and 750 / 862 through 60,000 / 80,000 / 100,000 kVA three phase.
13. C57.12.70 - Terminal Markings and Connections for Distribution and Power Transformers.
14. C57.12.80 - Terminology for Power and Distribution Transformers.
15. C57.12.90a - Test Code for Liquid-Immersed Distribution, Power and Regulating Transformers.
16. C57.13 - Requirements for Instrument Transformers.
17. C76.1 - General Requirements and Test Procedure for Outdoor Apparatus Bushings.
18. C76.2 - Electrical, Dimensional and Related Requirements for Outdoor Apparatus Bushings.

National Electrical Manufacturers Association (NEMA):

1. SG1 - Electric Power Connectors.
2. SG4 - Standards for Power Circuit Breakers.
3. SG5 - Electric Switchboards.
4. LA1 - Lightning Arrestors.
5. TR1 - Standards for Transformers, Regulators, and Reactors.
6. E1-2 - Instrument Transformers.

Applicable rules of the National Electrical Code and National Electric Safety Code.

Factory Tests:

All standard factory tests on equipment and all tests required by the applicable codes shall be made including:

1. Standard ANSI dielectric tests.
2. Standard circuit breaker tests.
3. Comprehensive tests of all systems and controls to assure proper assembly

and connection, including simulation tests of all safety devices.

Notify Owner and Engineer when factory tests are to be made so that they may have a representative witness the tests, if desired. Submit certificate of completion of all tests in triplicate.

PRODUCTS:

GENERAL: Design, fabricate, assemble, install, and test equipment in accordance with applicable standards specified above.

GENERATOR CONNECTION EQUIPMENT:

Provide generator surge protection equipment housed in a metal-enclosed dead-front enclosure, containing station-type lightning arresters and surge capacitors of proper rating to adequately protect the electrical apparatus. Surge protective equipment shall be physically arranged so as to be connected as close as possible to the generator terminals.

Provide generator neutral grounding distribution transformer and secondary resistor housed in a ventilated metal enclosure. Transformer and resistor shall be adequately sized for the generator based upon a one-minute rating.

RELAYING:

Provide all protective relays for the generator and auxiliaries as required for safe start-up, operation, and shutdown of the unit. See Section 8 for generator relaying requirements.

ELECTRIC MOTORS:

See SECTION 8.

SWITCHGEAR AND MOTOR CONTROL CENTERS:

480V switchgear, where provided, shall be metalclad dead front, indoor, 600V class equipment with drawout air circuit breakers and shall contain the following:

1. Air circuit breakers to have adequate interrupting capacity when fed directly from station auxiliary transformer.

2. Potential and current transformers for metering and relaying.

480V motor control centers shall be metal enclosed, dead front, NEMA Class II, Type B or C, equal to General Electric 8000 line and shall contain the following:

1. Air circuit breakers with adequate interrupting capacity when fed directly from station auxiliary transformer.
2. Motor starter and feeder circuit breakers of adequate quantity and size to supply all gas turbine auxiliary equipment.
3. Potential and current transformers for metering and relaying.

Three-phase ac circuit breaker panelboards shall have an adequate number and size of breakers to supply all equipment furnished.

125Vdc circuit breaker panelboard shall have an adequate number and size of breakers to supply all equipment furnished, plus a minimum of two 30-ampere or larger, two-pole breaker spare for Owner's future use.

BATTERY AND CHARGER:

Battery ratings shall be as follows:

1. 125Vdc.
2. Nominal 2.232V per cell.
3. Calcium-alloyed, lead-acid type.
4. Sized for 3 hours operation prior to recharging.

Charger ratings shall be as follows:

1. Input Voltage: 480V, 1 phase, 60 hertz.
2. Output Voltage: 125Vdc.
3. Output Current: Output as required carry continuous load plus recharge batteries in 6 hours.

TURBINE CONTROLS:

Provide a redundant microprocessor based control system to perform all control, monitoring, alarming, data logging, and communications associated with the turbine. Include local operator station, and remote operator station. Control system shall include redundant communications to the plant DCS system.

The control system shall include the following functions:

1. Automatic startup and shutdown.
2. Speed/load control.
3. Temperature control.
4. Automatic synchronizing.
5. Monitoring and display of temperatures, flows, and pressures.
6. Speed, temperature, vibration, and flame protection.
7. Self diagnostics.
8. Data graphing and trending.
9. Data historian.
10. Alarm logging.
11. Redundant sensors for critical points.
12. Graphical and tabular displays.
13. Remote communication.
14. System administrative functions and security.

Relaying and Metering:

1. See SECTION 8.2 for protective relaying requirements.
2. Provide hand reset lockout relays.
3. Meters and display for generator frequency, field current, field voltage, three phase current, three phase voltage, kW, kWh, kvar, kvarh, power factor, and switchyard voltage.
4. Complete automatic synchronizing equipment for generator breaker including synchronizing relay, synchronizing check cut-off relay, speed matching, and voltage matching relays.
5. Synchroscope, lamps, and switch.
6. Generator breaker control switch and lights.

WIRING:

The gas turbine, generator, and all auxiliary equipment shall be prewired to the maximum extent possible. The interconnecting wiring between all equipment furnished, except as otherwise specified, shall be furnished and installed by this Contract.

All low-voltage wiring of 600 volts or less shall consist of insulated conductors installed in zinc-coated rigid-steel conduit.

1. Conduit shall be sized and installed in accordance with the requirements of the National Electrical Code.
2. Low voltage wiring shall conform to the requirements of SECTION 8.

All high-voltage wiring above 600 volts shall conform to the requirements of SECTION 8.

Appropriate power and control cable terminals shall be provided within the unit enclosure for external cable terminations. Arrange for grouped entrance of external control and low-voltage connections, and provide cable tray or wireway systems in unit for connection of all 600-volt wiring from point of entrance to internal equipment.

All devices for nominal 125Vdc operation shall provide satisfactory operation for a range of voltage of 100 to 140 volts with a 120°F ambient temperature.

All electrical devices and wiring located under the casing of the machine or at other high-temperature locations shall be specifically designed and constructed of suitable materials to give satisfactory operation in the high ambient temperatures involved.

Low-level instrumentation circuits shall be run in separate conduits. Instrumentation terminal points shall be isolated from other voltage levels.

5.2.6 Steam Turbine (STG)

Contractor shall provide a steam turbine generator unit complete with auxiliaries, appurtenances, and accessories, as required by the manufacturer and as specified

herein, including all materials, services, and all required labor necessary for a complete functional installation, including all requirements for startup and testing.

Furnish the turbine generator unit complete with all piping between contiguous component parts, and with all wiring specified. All equipment and materials supplied shall be from manufacturers on the Approved Vendors List – Appendix B, unless approved by Owner. Contractor shall provide technical assistance and guidance for installation and placing the turbine generator unit into successful operation as specified.

Contractor shall provide technical review and coordination, shop inspection, expedition, shipping coordination, shipping inspections, receiving inspections, off-loading site storage and maintenance. Contractor shall submit an inspection program for Owner approval.

Design pressure, temperature and materials for all piping shall be based on the steam turbine manufacturer's standard, but not less than applicable ASME Boiler and Pressure Vessel Code and ANSI B31.1 requirements.

Contractor shall provide acoustical enclosures or lagging for noise control of the STG control valves to meet noise guarantees.

Applicable Codes and Standards: Design, fabricate, assemble, and test equipment so that upon installation and operation in accordance with manufacturer's recommended procedures for this application, the equipment will conform to the requirements of the applicable provisions of the standards including, but not limited to, the following or Engineer approved equivalent BS, ISO, or DIN standards:

1. American National Standards Institute (ANSI):
 - A. C1 - National Electrical Code (NEC)
 - B. C42.1 - Definition of Electrical Terms, Group 10 Rotating Machinery
 - C. C50.10 - Rotating Electrical Machinery - Synchronous Machines
 - D. C50.13 - Rotating Electrical Machinery - Cylindrical Rotor Synchronous Generators

2. American Society of Mechanical Engineers (ASME):
 - A. Boiler and Pressure Vessel Code
 - B. B31.1 - Power Piping
 - C. TDP-1 - Recommended Practice for the Prevention of Water Damage to Steam Turbines Used for Electric Power Generation
3. American Society for Testing and Materials (ASTM):
 - A. A194 - Carbon and Alloy Steel Nuts for Bolts for High-Pressure and High-Temperature Service
 - B. A437 -Alloy-Steel Turbine-type Bolting Material Specially Heat Treated for High-Temperature Service
4. Institute of Electrical and Electronics Engineers (IEEE):
 - A. 4 - Techniques for High Voltage Testing
 - B. 421 - Criteria and Definitions for Excitation Systems for Synchronous Machinery
 - C. 421a Guide for Identification, Testing, and Evaluation of the Dynamic Performance of Excitation Control Systems
 - D. 421b - Synchronous Machines, High-Potential Test Requirements for Excitation Systems
5. National Electrical Manufacturers Association (NEMA)
6. Tubular Exchanger Manufacturer Association (TEMA)
7. Hydraulic Institute (HI)

Experience: All equipment and material furnished shall have an acceptable history of satisfactory reliable service in central station use for a period of at least three years at comparable temperature, pressure, voltage, and design stress levels.

Newly-developed equipment with less than three years' actual service will be considered

from established manufacturers, only if it has been adequately tested, meets the requirements of this Contract, and is approved by Owner.

Factory Tests and Reports:

Before shipment, conduct the following tests:

1. Turbine Tests:
 - A. Mechanical balance
 - B. Overspeed test of rotors with blades at not less than 120% rated speed
 - C. Governor and control function operation
 - D. All standard factory tests
2. Generator Tests:
 - A. Mechanical inspection
 - B. Rotor balance, with rotor at normal maximum operating temperature
 - C. Rotor overspeed at 120% rated speed
 - D. Measurement of cold resistance of stator and rotor windings
 - E. Winding insulation resistance measurement
 - F. Standard IEEE 4 dielectric tests on stator and rotor
 - G. Pressure test on hydrogen-cooled stator frame for gas tightness (if provided)
 - H. Resistance temperature detector test
 - I. For liquid conductor cooled stators, test for flow continuity through windings
 - J. All standard factory tests
3. Provide Owner a list of all factory tests and a test schedule so that a

representative may witness the tests.

Results of tests shall be submitted to Owner for review. All factory test results shall be available for examination by Owner upon request.

5.2.6.1 General

Provide each turbine generator unit with all accessories and features normally included with a unit for erection. Arrange equipment and appurtenances for safe and ready access for operation and maintenance. Provide access into enclosures and appearance lagging as required for operation and maintenance.

Provide adequate ventilation in enclosures and appearance lagging for proper cooling of equipment. Provide cooling systems, where required, for equipment that will not operate satisfactorily due to ambient temperature. Control, excitation, and supervisory equipment room will be air conditioned to an ambient temperature of 80°F; however, in case of failure of air conditioning, equipment shall operate satisfactorily at 100°F for continuous periods up to 48 hours, with peaks of 50°C for 3-hour periods during the 48 hours.

Provide couplings for fans, pumps, and other motor-driven equipment as follows:

1. All couplings shall be rated at not less than 140% of the motor horsepower.

Flexible drive couplings shall be as follows:

- A. Designed to prevent any external thrust from being transmitted to the driver shaft under normal operating conditions
- B. Fast gear type, flexible disc type, or approved equal
- C. Equipped with rainhood or cover for outdoor installations

2. Drive couplings shall have guards as follows:

- A. Complying with all applicable state and federal safety requirements
- B. Arranged for ease of disassembly or removal for access to coupling
- C. Rigidly fastened to baseplate

- D. Conform to other specific requirements of these Specifications, as applicable
3. Bolts, nuts, screws, and other standardized fasteners shall conform to the applicable ASTM A194 or A437 standards, except where higher standards for high temperature and pressure are deemed necessary by the manufacturer. Provide tools and wrenches for each nonstandard item.
 4. Provide preservation and protection, suitable for overseas shipment and storage as specified in DIVISION 1. Submit description and details of preservation and protection systems and recommended storage procedures.
 5. Unit shall be designed, constructed, and balanced statically and dynamically so that vibration displacement at the bearings at synchronous speed through full-load operation will not exceed Contractor's recommended operating limits.
 6. Provide one set of electric bolt heaters, all special erection tools, lifting devices, special instruments, and other special equipment required for erection and installation of the unit. Provide metal storage cabinet for all special tools, wrenches, and instruments.
 7. Provide temporary valve cover plates complete with pipe spools with weld end preps, and internal protective shields as required for main stop and reheat stop valves, for steam blowdown. Provide at least one complete set, suitable for use on up to eight turbines.
 8. Provide lifting lugs to facilitate disassembly and maintenance. All piping that must be removed for overhaul of turbine shall be equipped with lifting lugs that protrude through the heat insulation. Provide a lifting beam so that the crossover piping (if applicable) can easily be removed as a single unit during disassembly.
 9. Hanger assemblies, anchors, and sway braces shall be designed in accordance with the latest editions of the MSS Standard Practice SP-58 and SP-69. Design for seismic zone and building code specified in DIVISION 1.

5.2.6.2 Turbine

The turbine shall be of the multivalve, multistage type. Single governor valves are not permitted. All parts which are subject to temperature changes shall be designed and supported so as to permit free expansion and contraction in order to minimize distortion or misalignment.

Turbine Casings:

1. The casing shall be supported at the centerline, with flexible supports at the high-pressure end.
2. Provisions shall be made in the design of the turbine to control thermal stresses in the turbine casing.
3. Special provisions shall be made in all bolting 50 mm in diameter and larger for tightening.
4. The bearings shall be arranged to permit inspection without removal of the turbine casing.

Turbine Rotor:

1. The rotor shall be of forged construction, with wheels forged integrally with the shaft, as required by design operating conditions. Dovetailed grooves shall be turned in the wheels to securely hold the individual blades.
2. The completed turbine rotor shall be balanced in the manufacturer's plant in order to run smoothly and without excessive vibration.
3. Provisions shall be made in the design and manufacture of the rotor to minimize stress concentrations.

Turbine blading shall be stainless steel and shall be securely and adequately anchored and shall be readily renewable. Welding of blading to wheel disc will not be acceptable in any stage.

Diaphragms:

1. All diaphragm blading shall be of stainless steel.
2. Each diaphragm shall be split along the horizontal centerline and a doweled tongue and groove joint shall be provided to assure correct alignment and prevent interstage leakage.
3. The diaphragm halves shall be securely positioned in the casing of inner element.

Bearings:

1. All bearings shall be designed for pressure lubrication and shall operate without injurious temperature rise or undue wear.
2. All bearings shall be split to permit removal for inspection and shall be removable without removing the rotor.
3. All main bearings shall be provided with a positive visual check for oil flow through the bearings via sight flow indicators. Leakage of oil or oil vapors from the bearing housings shall be minimized.
4. A double-acting tilting pad, multisegment thrust bearing shall be provided to align and maintain the correct axial relationship between the rotating and the stationary parts.

All turbine drains and low point pipe drains will be piped to the condenser. The drain valve controls will be per the manufacturer's recommended design and in general accordance with ASME TDP-1.

Complete control and protective valve system including the following:

1. Main stop valves designed to withstand boiler hydrotest pressure of 1.5 times HRSG drum pressure.
2. Control valves automatically controlled by governor system.
3. Turbine anti-motoring sensor.
4. Devices as required for use with control and monitoring systems specified

below to allow sequential remote testing of main stop valves, and control valves, while turbine is in operation.

5. Provide first-stage pressure sensor, for steam flow measurement.
6. Coarse mesh screens with removable fine mesh start-up screens, removable without disturbing inlet piping, or permanent fine mesh strainers, for main stop valves.
7. Proximity switches for main stop valves, and control valves, with two N.O. and two N.C. electrically separate pairs of contacts for Owner's use at each end of each valve mechanism with space for additional special switches specified below.
8. Hydraulic system trip interlock pressure switch with two electrically separate contacts for Owner's use, for tripping of generator and electrical auxiliary system upon tripping of turbine, if such tripping interlock scheme is recommended by the manufacturer. Provide indication of what caused the turbine to trip.
9. Power-operated drain valves, equipped with solenoid valves and limit switches on each valve if pneumatically operated, and piping between turbine and drain valves. Valves will be operated from the turbine control system. If motor-operated valves are furnished, provide position transmitters in addition to limit switches on each valve. Provide double valves at all steam drains above 400 psig. Where power-operated valves are provided, the first valve shall be manually-operated and provided with a locking device. High-pressure steam drain valves shall have the following:
 - A. Pressure seal bonnet for valves 4 inches and larger, no bonnet or welded bonnet for valves 3 inches and smaller
 - B. Butt-welding ends for valves 2½ inches and larger, socket weld ends for valves 2 inches and smaller
 - C. to 14% chromium steel trim
 - D. Stellite or 11.5 to 14% chromium disc and seat facings.

- E. Integral stellited or 11.5 to 14% chromium back-seating surface
 - F. 600-, 900-, 1500-, or 2500- class cast steel or forged steel bodies, complying with applicable ANSI standards
 - G. Valves shall be manufactured by vendor listed in Appendix B – Approved Vendor List
10. Piping between main stop valves and turbine as required to locate valves either out from under the turbine and its foundation, or above its foundation, including all necessary hangers and supports for the valves and piping.

Exhaust casing spray nozzles with automatic control and internal turbine piping. Include diaphragm (or solenoid) control valve and sensing element for control.

Motor-operated or hydraulically operated turning gear including the following:

1. Turbine control system shall be capable of automatically starting and engaging turning gear.
2. Provide for local manual turning gear (or hydraulic oil pump) motor starting and turning gear engagement should the automatic feature fail.
3. Interlock with lubrication system to prevent operation without bearing lubrication.
4. Zero speed device to prevent automatic starting or engagement while rotor is turning.
5. Electrically separate alarm contacts to indicate zero speed and turning gear disengagement.

All required protective devices including the following:

1. Exhaust hood atmospheric relief diaphragms.
2. Exhaust hood high-temperature alarm.
3. Thrust bearing failure detector with trip function.

4. HP/IP Shell casing packing dump valve if required.

Provide all instruments required to monitor operation of the turbine unit. Instruments shall include at least the following:

1. Thermocouples for at least the following:
 - A. Turbine shells, exhaust hoods, valve casings, and as otherwise required for controlled starting and warm-up
 - B. Thrust bearing shoes
 - C. Main bearing metal temperatures including generator bearings
 - D. Main bearing oil drains including generator bearings
 - E. Thrust bearing oil drains
 - F. Oil inlet and oil outlet of oil coolers
 - G. Hydraulic fluid in and out of coolers
 - H. Lube oil reservoir
2. Thermometers for at least the following:
 - A. Main bearing drains including generator bearings
 - B. Thrust bearing drains
 - C. Exhaust hood
3. Pressure gauges for at least the following:
 - A. Exhaust hood water spray
 - B. Gland condenser vacuum
 - C. Steam chest
 - D. First-stage steam

- E. HP turbine exhaust steam
 - F. LP turbine exhaust steam
 - G. Gland steam header
4. Electronic pressure transmitters for the following:
- A. Lube oil header
 - B. Throttle (before stop valve)
 - C. Control valve chest (between stop and control valve)
 - D. Turbine First Stage
 - E. LP inlet stage
 - F. Turbine Exhaust
 - G. Electrohydraulic control fluid pressure
 - H. Gland steam pressure
5. Provide smart transmitters per the requirements in SECTION 9.

Rotor ground device and grounding pad on exhaust hood and/or bearing standard.

Heat retention insulation for the following:

1. Upper and lower turbine shells.
2. Steam valve bodies.
3. Exhaust casings where required.
4. All steam piping furnished with unit.
5. Horizontal and vertical joints. Provide reusable blankets.

Insulation jacketing as follows:

1. Aluminum jacket for all insulated piping.

2. Removable insulation-filled stainless steel covers for the following:
 - A. Main stop valves.
 - B. Valve flanges at turbine shells.
 - C. Flanges in crossover pipes.

Metal appearance lagging over HP turbine shells and associated stop and control valves and piping to shells.

Moisture protection system for low-pressure stages.

Exhaust connection suitable for welding to condenser neck.

Shims, subsole plates, leveling plates, seating plates, and sole plates.

5.2.6.3 Electrohydraulic Control System

System shall automatically position the various valves listed above as required to control the turbine-generator speed and load under varying conditions plus trip the unit when overspeed or other abnormal conditions occur. Provide means to initiate and monitor sequential remote testing of the valves and other protective and trip devices during operation of the unit.

Hydraulic portion of the system shall be independent of lubricating oil system complete with reservoir, multiple ac motor-driven pumps, hydraulic fluid coolers, accumulators, filters, strainers, instruments, controls, valves, and all required supply and return hydraulic fluid piping to the main turbine.

1. Instruments and controls in the hydraulic portion of the system shall include at least the following:
 - A. Suction and discharge pressure gauges on all pumps and on the discharge header.
 - B. Pressure switches for control of all electrohydraulic fluid pumps.
 - C. Thermometers on electrohydraulic fluid lines at the inlet and discharge of coolers.

- D. Temperature controllers and cooling water control valves to regulate electrohydraulic fluid temperature at the discharge of each cooler.
- E. Instrument and sensors to provide electrically separate alarm contacts for Owner's use for the following:
 - 1) Electrohydraulic fluid reservoir high level.
 - 2) Electrohydraulic fluid reservoir low level.
 - 3) Electrohydraulic fluid reservoir low-low level.
 - 4) Electrohydraulic fluid system low pressure.
 - 5) Electrohydraulic fluid temperature high.
 - 6) Electrohydraulic fluid system filters dirty.
 - 7) Others as required by the turbine supervisory and control systems.

Instruments and sensors as required by the turbine supervisory and control systems for operation of turbine.

- 2. All piping shall be stainless steel with welded joints and a minimum of flanged connections. Piping shall be cleaned internally and then sealed using weld caps or blind flanges before shipment.
- 3. System shall use turbine manufacturer's standard fire resistant fluid or Owner approved equal.

5.2.6.4 Turbine Control System

The control system shall provide supervisory control of turbines, turbine auxiliaries, generators, and generator auxiliaries. The system shall provide startup, operation, load change, and shutdown, as well as monitoring, alarming, and safety trips for the steam turbine generator unit.

The turbine control system shall be interfaced to the plant DCS control system through a redundant communications link. All operator functions shall be capable from the plant DCS control system. Contractor shall provide a turbine control system that meets the following requirements and the DCS control system requirements in SECTION 9.

The turbine control system hardware will be installed in close proximity to the steam turbine. Provide a remote operator station for the main control room and a local operator

station for the electrical equipment room. Remote operator station shall have identical hardware and software as the local operator station.

Provide means to initiate and monitor sequential remote testing of the valves and other protective and trip devices during operation of the unit.

Provide all sensors, transducers, and transmitters required by the system.

Provide all control, logic and input-output modules, associated power supplies, and related items, installed in a system cabinet assembly, to perform the control functions specified herein.

Provide electrically separate alarm contacts for the DCS use for at least the following:

1. Turbine trip
2. Pre-trip and trip alarm contacts for every turbine trip condition
3. System power supply failure
4. Others as required or recommended by manufacturer

Provide capability of operating in any of the following modes as selected by the operator:

1. Coordinated Boiler-Turbine Mode using a load demand signal generated by Owner's automatic load dispatching system.
2. Coordinated Boiler-Turbine Mode using a load demand signal manually generated from DCS.
3. Boiler Following Mode with turbine valves maintaining speed or load.
4. Turbine Following Mode with turbine valves controlling throttle steam pressure.

Provide a hard wired interface from the turbine control system to DCS for all critical controls, indicators, and interlocks.

Provide controls to allow DCS to immediately reduce the load on the steam turbine

generator. The immediate response of the system shall be impeded upon only by the constraints of the hydraulic system.

5.2.6.5 Turbine Rotor Stress Monitoring

System shall automatically and continuously calculate rotor stresses that occur when temperatures change with machine loading.

System shall operate on the turbine control system hardware.

System shall be capable of operating in at least two separate modes. These modes are:

1. Monitor: In this mode, the system makes available to the operator data required for safe and proper operation of the turbine-generator unit. In this mode, system performs no control functions and all decisions regarding changes in speed or load, rates of change, and other variables are left to the operator.
2. Control: In this mode, the system shall automatically prevent the operator from changing unit load or turbine speed if limits established by the automatic control program or by the operator are exceeded. The system shall also be capable of automatically ramping the turbine from turning gear speed to a target speed, initiating a signal to automatically synchronize the turbine-generator unit, and loading the unit to a target load at a rate selected by operator or as limited by the automatic control program.

Provide all sensors and transducers required by the system.

5.2.6.6 Turbine Supervisory System

System shall automatically monitor at least shaft vibration, vibration phase angle, eccentricity, differential casing and rotor expansion, metal temperatures, speed, and control valve position. Display essential values continuously and alarm any abnormal condition during start-up and operation.

Provide all sensors and transducers required by the system.

Display all information on the turbine control system interface and plant DCS display.

Provide alarms for at least the following:

1. High vibration for all bearings.
2. Rotor eccentricity off normal.
3. Differential expansion off normal.
4. Rotor position alarm.

5.2.6.7 Lubrication System

The turbine lube oil system shall be installed, cleaned, and flushed according to the manufacturer's specifications. Lube oil type and purity shall be in accordance with the steam turbine generator manufacturer's specifications.

Provide a complete lubrication system including but not limited to the following:

1. Oil reservoir with oil level indicator and oil level alarms. Reservoir shall have adequate capacity above maximum lube oil high level alarm to receive the flowback from the lube oil system under tripout conditions
2. Full-capacity positive-displacement or centrifugal-type main oil pump, either shaft-driven or with ac motor drive
3. Full-capacity positive-displacement or centrifugal-type auxiliary oil pump with ac motor drive
4. Positive-displacement or centrifugal-type emergency oil pump with dc motor drive and starter
5. Oil coolers, either two full-capacity or one three-section type with two sections capable of carrying full capacity
6. Transfer valve so that one tube bundle or section can be removed while remaining cooler or sections are in operation
7. Vapor extractor with ac motor drive

8. Lube oil demister
9. Removable strainers for use during start-up at each bearing inlet and at oil return to reservoir, and at other locations as required by manufacturer
10. Lube oil heater interlocked with a low oil reservoir liquid level switch for alarm and to trip the heater to prevent a fire

Provide instruments required for operation. Instrument signals shall be integrated into the turbine control system. Instruments shall include at least the following:

1. Pressure gauges on all pump suction and discharge lines and on the lube oil header
2. Pressure switches for control of all lube oil pumps
3. Thermometers on oil lines at the inlet and discharge of lube oil coolers
4. Thermocouple complete with well for control of cooling water flow
5. Lube oil reservoir level high
6. Lube oil reservoir low level switch
7. Lube oil reservoir level transmitter
8. Differential pressure switch across filters
9. Emergency lube oil pump running
10. Redundant pressure switch to start dc emergency oil pump. Switch shall be located at a different location from the other pressure switch.
11. Others as required by the turbine control system
12. Loss of ac power relay to start dc emergency pump

Provide all required lube oil supply and return piping. Oil pressure piping shall be seamless steel with welded joints, and a minimum of flanged connections. Oil piping shall be thoroughly cleaned by pickling and then sealed using weld caps or blind flanges before shipment. For protection against fire, oil piping shall be suitably shielded with no

flanged joints located above or adjacent to hot surfaces. All lubricating oil piping under pressure in high temperature areas shall be contained within a drain or return line, or within a tight housing which is suitably drained back to a reservoir. Drains shall have adequate capability of returning the oil supplied to any area in the event of a complete rupture of the oil supply pipe in that area. All drain pipes shall be sloped to provide complete drainage of the system back to the lubricating oil reservoir.

5.2.6.8 Gland Steam System

Provide a complete gland sealing system including but not limited to the following:

1. Steam seal pressure control valves, one for each steam source and one for dump to condenser
2. Full-flow gland steam condenser with two ac motor-driven exhausters, both permanently mounted to the condenser
3. Power-operated diaphragm shutoff and bypass valves with remote position indicators as required to manually control gland steam from the turbine control system should regulators fail
4. Valves and all required piping from pressure control valves to turbine and from turbine to gland condenser
5. The gland sealing system shall have the following features:
 - A. The gland sealing system shall not require an external source of steam other than main steam at throttle conditions, or drum steam after pressure reduction. An auxiliary supply of saturated steam shall be provided by Contractor to seal the turbine prior to start-up.
 - B. Gland leakage shall be returned to the cycle by the gland sealing system provided, except such portions as may be contaminated by air or oil vapor.
 - C. Gland steam valves shall be of an Owner-approved type with stellite or 11.5 to 14% chromium seats.

- D. Provide removable flanged spool piece at each connection to the turbine gland seal piping to facilitate steam cleaning of the gland steam system in accordance with the manufacturer's recommendations.
6. Provide all instruments required for operation. Instrument signals shall be integrated into the turbine control system. Instruments shall include at least the following::
- A. Low steam seal pressure switch
 - B. High water level switch in gland steam condenser
 - C. Gland steam temperature sensor

5.2.7 Combustion and Steam Turbine Electrical Generator

5.2.7.1 General:

Generator shall be cylindrical rotor type designed, constructed, and rated in accordance with applicable standards for specified service conditions.

The steam turbine generators will be connected to the delta wound primary of the Generator Step-up (GSU) Transformer. The secondary of the GSU will be solidly connected grounded type wye configuration. The unit will be synchronized across the high side switchyard breaker. See SECTION 8 for additional requirements.

The gas turbine generators will be connected in a high resistance grounded wye configuration through a neutral grounding transformer with neutral grounding resistor connected to transformer secondary. The generator will be connected to a low side generator breaker that is connected to the low side of the GSU. The unit will be synchronized across the low side breaker. See Section 8 for additional requirements.

5.2.7.2 Applicable Codes and Standards

Design, fabricate, assemble, and test equipment so that upon installation and operation in accordance with manufacturer's recommended procedures for this application, the equipment will conform to the requirements of the applicable provisions of the standards (or equivalent IEC standards) including, but not limited to, the following:

1. American National Standards Institute (ANSI):
 - A. B31.1 - Code for Pressure Piping - Power Piping
 - B. C1 - National Electrical Code
 - C. C42.1 - Definition of Electrical Terms, Group 10 Rotating Machinery
 - D. C50.10 - General Requirement for Synchronous Machines
 - E. C50.13 - Cylindrical Rotor Synchronous Generators
 - F. C57.13 - Requirements for Instrument Transformers
2. American Society of Mechanical Engineers:
 - A. Boiler and Pressure Vessel Code
 - B. B31.1 - Power Piping
3. American Society for Testing and Materials (ASTM):
 - A. A194 - Carbon and Alloy Steel Nuts for Bolts for High-Pressure and High-Temperature Service
 - B. A437 - Alloy-Steel Turbine-Type Bolting Material Specially Heat Treated for High-Temperature Service
4. Institute of Electrical and Electronics Engineers (IEEE):
 - A. 4 - Techniques for Dielectric Tests
 - B. 21 - Outdoor Apparatus Bushings, General Requirements and Test Procedure
 - C. 32 - Neutral Grounding Devices
 - D. 421 - Criteria and Definitions for Excitation Systems for Synchronous Machinery
 - E. 421a - Guide for Identification, Testing, and Evaluation of the Dynamic Performance of Excitation Control Systems

F. 421b - Standard for High-Potential Test Requirements for Excitation Systems for Synchronous Machines

5. National Electrical Manufacturers Association (NEMA).
6. Tubular Exchanger Manufacturer Association (TEMA).

5.2.7.3 Quality Assurance

All equipment and material furnished shall have an acceptable history of satisfactory reliable service in central station use for a period of at least three years at comparable temperature, pressure, voltage, and design stress levels.

Newly-developed equipment with less than three years' actual service will be considered from established manufacturers, only if it has been adequately tested, meets the requirements of this Contract, and is approved by Owner.

5.2.7.4 Factory Tests

All standard factory tests on equipment and all tests required by the applicable codes shall be performed including:

Mechanical inspection.

1. Rotor balance, with rotor at normal maximum operating temperature.
2. Rotor over-speed at 120% rated speed.
3. Measurement of cold resistance of stator and rotor windings.
4. Winding insulation resistance measurement.
5. Standard IEEE 4-1978 dielectric tests on stator and rotor.
6. Pressure test on hydrogen-cooled stator frame for gas tightness (if provided).
7. Resistance temperature detector test.
8. Lubricating systems including hot oil flushing and bearing inspection.
9. Comprehensive tests of all systems and controls to assure proper assembly

and connection, including simulation tests of all safety devices.

Provide Owner and Engineer a list of all factory tests and a test schedule so that they may have a representative witness the tests, if desired.

Submit certificate of completion of all tests and test reports for all tests. All factory test results shall be available for examination by Owner upon request.

5.2.7.5 Submittals

Submittals required shall include all manufacturer's drawings necessary for design, installation, and operation of equipment furnished, including the following:

1. General outline, base plans, and general arrangement drawings
2. Detailed installation drawings showing foundation details, location connections, weights, and all clearances required for erecting, operating, and dismantling
3. Complete loading diagrams covering static and dynamic loadings for all conditions of operation
4. Schematic wiring diagrams showing all external connection terminal block numbers
5. Complete connection diagrams showing all internal wiring
6. Power and instrument transformer connection and polarity diagrams
7. Instrument transformer performance curves and data
8. Bills of material
9. Drawings showing additional detail if requested by Engineer, or if otherwise required for installation and maintenance

Wiring drawings shall include connection drawings both internal and external, NEMA Standard across-the-line industrial control schematic drawings for all control systems provided or designed by Contractor, physical location drawings for all terminal blocks, and power requirements.

5.2.7.6 Products

GENERAL: Generator stator core shall be so designed and constructed (or flexibly mounted) as to minimize the effects of 120-cycle vibrations on stator frame, foundation, and other structures.

Generator cooling system shall be totally enclosed hydrogen cooled or Totally Enclosed Water Air Cooled (TEWC) with Class F insulation on stator and rotor and limited to Class B temperature rise.

GENERATOR:

1. Minimum net continuous rating of 105% of the turbine peak output at 85% lagging to 95% leading power factor
2. General output voltage $\pm 5\%$ of nominal
3. TIF maximum (1960 weighting), balanced: 40
4. TIF maximum (1960 weighting), residual: 30
5. Minimum short circuit ratio at rated hydrogen pressure: 0.5.

COOLING SYSTEM:

1. The internal generator cooling air shall be adequately filtered and controlled to permit operation without adverse effects on the service life of the insulation or condensation and corrosion of generator iron.

EXCITATION SYSTEM:

1. Provide self-excited main exciter of brushless or static type, having stabilized voltage.
2. Provide control system with fast-acting response, and suitable voltage regulator arranged for local and remote control.
3. Provide excitation control breaker and field discharge or field suppression contactor and resistor.

4. Provide all necessary current transformers, potential transformers, relays, protective devices, and supervisory safety monitoring devices.
5. Generator excitation equipment shall be housed in a metal-enclosed NEMA dead-front enclosure and contain the following:
 - A. Excitation control circuit breaker or field suppression control
 - B. Linear field discharge resistor if required
 - C. Voltage regulator
 - D. Ammeter shunt
 - E. Regulator shall be equipped with tie-line power factor compensation, cross-current compensation, and maximum and minimum excitation limits
 - F. Provisions to interface with distributed control system (DCS) for remote reactive power and voltage control
6. General:

All excitation system voltage response ratios stated herein are to be as defined and recommended in IEEE 421, and shall be determined with the excitation system connected to the generator field, or an equivalent resistive load as described by IEEE 421a. A factory test or an analytical method may be used in determining acceptance of the voltage performance.

7. Provide a complete excitation system of one of the following types:
 - A. Static type including the following:
 - 1) Provide separate dry-type power potential transformer in a free-standing metal enclosure provided with high voltage bushings and flanges for connection to isolated phase bus duct. Overcurrent relay and associated CTs for transformer protection shall be provided.

- 2) Collector enclosure with internal illumination, hinged access doors, observation windows, and ventilation system.
 - 3) Metal-enclosed excitation cubicles with voltage regulator, generator supply breaker, field ground detector, silicon rectifiers, and all required control circuits and accessories.
- B. Brushless rotating rectifier type including the following:
- 1) Permanent magnet pilot exciter, ac exciter, and a diode and fuse wheel directly connected to the generator shaft. Each diode must have series fuse.
 - 2) Exciter enclosure with internal illumination, hinged access doors, observation windows, and cooling system.
 - 3) Metal-enclosed excitation cubicles with voltage regulator, exciter supply breaker, automatic field ground detector, and all required control circuits and accessories.
 - 4) Furnish an excitation system communication interface to the plant distributed control system to allow operator to monitor and control the excitation system.
8. Provide the following special excitation system features:
- A. Ten additional auxiliary contacts on exciter field breaker. This may be by the addition of a multi-contact auxiliary relay
 - B. Provide field ground detection relays for main generator and exciter field
 - C. Fuses and terminal blocks for all components of excitation system requiring 220 volts ac or 125 volts dc station service power
 - D. Line drop compensation for voltage regulator
 - E. Maximum and minimum excitation limit equipment
 - F. Two-step maximum volts per hertz excitation protection and limiter

- G. Provisions for the addition of supplemental excitation controls to control excitation in response to generator rotor angle
- H. Dual input power system stabilizer utilizing integral of accelerating power with system studies, settings, and field tuning
- I. Provide main generator field ground detection relay with proper sensitivity and adequate security to use to trip the unit. Provide unit with time delay to prevent trip for momentary field ground
- J. Automatic regulator tracking control for manual regulator.
- K. Regulator and power system stabilizer output status contacts to Owner's SCADA system.
- L. Provide transducers with 4 to 20 mA output to Owner's DCS for exciter field voltage and current.
- M. Hydrogen/temperature Limiter Compensation.
- N. Overvoltage trip.
- O. Provide field overcurrent protection system that has characteristics similar to the thermal capability of the rotor so as to permit full utilization of the rotor thermal capability, but that will positively prevent overcurrent which could damage the rotor. An offline field current limiter shall be provided
- P. Field flashing system for operation using station 125V battery, or separate 460-volt, 3-phase system.
- Q. The exciter shall be capable of maintaining 2.0 pu., or greater, excitation voltage while generator terminal voltage is 0.5 pu
- R. Power factor and VAR automatic control.
- S. Communication ports to Owner's DCS.
- T. Off line excitation protection.
- U. Display panel with self diagnostics

HYDROGEN SYSTEM: (As applicable if Provided by OEM for cooling)

1. Provide hydrogen coolers arranged and sized with adequate capacity to provide 80% generator capability with one isolatable cooler, or section (as applicable), out of service. All fasteners (nuts, bolts, and similar items) exposed to the cooling water shall be stainless steel. Arrange cooler vents for convenient access below the operating floor
2. Provide hydrogen bottle manifold including pressure gauges, shutoff valves, mounting brackets, bottle connectors, piping and a single shutoff valve. Provide a flanged removable section of pipe between the hydrogen shutoff valve and generator for removal while performing generator maintenance.
3. Provide carbon dioxide and nitrogen bottle manifolds including pressure gauge, shutoff valves, mounting brackets, bottle connectors, and single shutoff valve.
4. Provide piping, valves, regulators and analyzer as follows:
 - A. Generator hydrogen pressure regulator with shutoff valves and bypass line
 - B. Purging control valve assembly
 - C. Purging gas analyzer
 - D. Welded steel gas control system piping
5. Provide instrument and controls as follows:
 - A. Electronic transmitters as follows:
 - 1) Generator hydrogen purity
 - 2) Generator hydrogen pressure
 - 3) Generator fan differential pressure
 - 4) Hydrogen density

- 5) Hydrogen dewpoint
- B. Sensors as required to provide at least the following alarms at the hydrogen controls cabinet.
- 1) Generator hydrogen purity high and low
 - 2) Generator hydrogen pressure high and low
 - 3) Hydrogen supply pressure low
 - 4) Generator hydrogen temperature high
 - 5) High Hydrogen dewpoint
 - 6) Others as required by manufacturer
- C. Temperature detectors to include the following: (Detectors listed below are for Owner's use. Any that are required by the turbine control or supervisory system dual detectors shall be furnished.)
- 1) One RTD for each hydrogen cooler gas inlet and outlet.
 - 2) One thermocouple and well in combined gas stream on the outlet of coolers for control of Owner's cooling water valve.
 - 3) Two RTDs in combined gas stream on the outlet of hydrogen coolers.
6. Provide hydrogen control cabinet including the following:
- A. Generator hydrogen pressure indicator.
 - B. Generator hydrogen purity indicator.
 - C. Fan differential pressure indicator.
 - D. Generator gas density indicator.
 - E. Generator cold gas temperature indicator.
 - F. Seal oil differential pressure indicator.

- G. Stator coils water flow indicator, if applicable.
 - H. Stator coils water tank pressure indicator, if applicable.
 - I. Stator coils water pressure differential indicator, if applicable.
 - J. Conductivity recorder for conductor liquid cooling system (if applicable).
 - K. Hydrogen system SCAM-Panalarm Series 80 solid-state annunciator or
 - L. Engineer's approved equal with isolated alarm contact output for each window for Owner's use.
 - M. Complete internal panel piping and wiring.
 - N. Provide space heater and thermostatic alarm control for auxiliary panels.
7. Redundant trains shall have isolation valves to allow maintenance with one train out of service.

MISCELLANEOUS:

- 1. Provide the following materials equipment and instruments:
 - A. Six high-voltage bushings
 - B. Temperature detectors to include six RTD's per phase embedded in stator windings
 - C. Generator field flux probe permanently mounted
 - D. Field retaining ring Material shall be 18 Mn 18 Cr
 - E. Partial Discharge Detectors mounted in stator slots
 - F. Fiber optic end winding mounted accelerometers
 - G. Grounding pads
 - H. Terminals for testing bearing and seal housing insulation on at least one
 - I. generator bearing and both bearings of a rotating exciter

- J. Foundation plates, shims, and sub-sole plates
- K. Metal appearance lagging from floor to centerline of generator
- L. Set of lifting slings, special tools and wrenches, air gap shim, and field shoe for assembly of rotor, and one set of lifting or jacking trunions
- M. Generator casing liquid detector
- N. Bushing current transformers shall be as follows:
 - 1) Provide bushing current transformers as required for relaying and metering
 - 2) Bushing current transformers shall meet ANSI accuracy class of C-800 for relaying, or 0.3B1.8 for metering
- O. Bushings designed and arranged for termination of isolated phase bus duct
- P. Neutral terminals shall be interconnected and completely enclosed in a properly ventilated enclosure with provision for connection to neutral grounding equipment
- Q. Field temperature indicator transmitter including field current shunt in dc bus, if applicable
- R. Vibration monitoring probes
- S. Generator balanced voltage wave shape shall limit the open circuit telephone influence factor to the current standards, based on 1960 weighting factors, or provide at no additional cost all necessary accessories with isolated phase construction required to meet the standards
- T. Generator stator and windings, including series loops and end turns (end turns not fully insulated on gas-cooled stators), shall be fully insulated so as to be satisfactorily tested in accordance with the high potential tests required by IEEE Standard 4, and in a manner satisfactory to Engineer.

Contractor shall submit details of insulation for review and approval prior to award of Contract

HEAT EXCHANGERS:

1. Exchangers with water source from treated raw water:
 - A. Tubes shall be 20 BWG minimum, stainless steel
 - B. Tube sheets shall be Contractor's standard
 - C. Channels and cover plates shall be aluminum bronze
 - D. Water sides of coolers to be designed for the pressure and cooling water temperature as required by Contractor's design
 - E. Minimum tube size shall be 5/8 inch nominal diameter
2. Exchangers in condensate cycle (Refer to SECTION 5):
 - A. Tubes shall be adequate for design pressure as required by Contractor's design
 - B. Tubes for gland steam condenser shall be stainless steel
 - C. Tube sheets shall be Contractor's standard material
 - D. Channels shall be fabricated steel
 - E. Designed for the water temperature ranges as required by Contractor's design
 - F. Minimum tube size shall be 5/8 inch nominal diameter
3. Exchangers in bearing cooling water system (Refer to SECTION 5):
 - A. Designed for design pressure and temperature as required by Contractor's design
 - B. Tubes shall be stainless steel minimum 22 BWG
 - C. Tube sheets shall be Contractor's standard material

D. Channels shall be fabricated steel

E. Minimum tube size shall be 5/8 inch nominal diameter

ELECTRICAL DEVICES:

1. Electric indicating instruments shall be semi-flush mounting, long-scale type, 5 inches square with black metal case, General Electric type AB-40 or DB-40.
2. Position and limit switches shall be suitable and adequate with mountings and actuators as required to provide reliable operation.
3. Alarm switches shall have contact ratings of at least 0.25 amperes at 125 volts dc and shall close for alarm.
4. All control devices such as relays and solenoids for nominal 125-volt dc operation shall provide satisfactory operation for a range of voltage from 90 to 140 volts with a 50°C ambient temperature where obtainable.
5. All electrical devices and wiring located under the casing of the machine shall be specifically designed and constructed of suitable materials to give satisfactory operation in the high ambient temperatures involved.
6. All electrical equipment and devices furnished on the turbine generator unit and its auxiliaries shall be wired out to conveniently located, oversized, terminal boxes for Owner's external wiring connections. Terminal boxes shall be NEMA 12. Terminals shall be marked as designated by Owner.
7. Motors shall conform to SECTION 8 and the following:
 - A. Size motor to operate at less than nameplate horsepower over the capability range of the driven equipment
 - B. Motor insulation shall be NEMA Class F, with Class B temperature rise in accordance with NEMA MG1
 - C. Suitable for across-the-line starting
 - D. Provide TENV or TEFC enclosures for all motors

8. Provide disconnect-type combination motor starters, completely wired, for all dc motor-driven auxiliaries provided by this Contract.

CONTROL PANEL EQUIPMENT:

1. Construction:
 - A. Provide panels and cabinets, totally enclosed, self-supporting
 - B. Provide hinged access doors and/or removable panels as required
 - C. Factory mount all instruments, control switches, and other devices at locations approved by Owner
 - D. Smooth, fill, prime and paint panels with two coats of finish paint of manufacturer's standard color subject to the approval of Engineer
 - E. Wire and tube completely in factory
 - F. Provide panels or insert panels to match Owner's panels provided under other contracts
2. Panel Wiring Terminal Blocks:
 - A. Terminate all connections requiring external wiring at terminal blocks, suitable for ring-tongue type connectors
 - B. Identify each terminal on each block by stamping or painting the circuit identification number
 - C. Provide manufacturer's standard terminal blocks subject to approval of Owner
3. Panel Wiring:
 - A. Wire with no splices and with all connections made on equipment studs or terminal blocks. Make all connections with insulated, ring-tongue terminals
 - B. Provide General Electric type SIS Specification SI-57275, or standard

conductor switchboard wire insulated for 600 volts

- C. Provide extra flexible hinge wire in areas subject to flexing such as hinged panels and doors
- D. Install in wiring troughs or channels with removable covers for easy accessibility to interior panel wiring

GENERATOR SURGE PROTECTION AND POTENTIAL TRANSFORMER EQUIPMENT:

1. Ratings:

A. Potential Transformers:

- 1) Voltage and BIL as required, 60 Hz.
- 2) Thermal capacity of at least 1000-volt amperes and metering accuracy of 0.3 for burdens W, X, Y, Z, and ZZ, when applied at rated voltage.
- 3) Thermal capacity of at least 580-volt amperes and metering accuracy of 0.3 for burdens W, X, Y, and J.6 for burden Z, when connected line-to-neutral.

B. Surge Arresters:

- 1) Proper rating design for rotating machine protection of the generator. Furnish an operation counter with each arrester.

C. Surge Capacitors:

- 1) Rated for the application and sized at 0.25 micro farads or as recommended by manufacturer.

D. Provide with dual secondary windings: One winding connected in a wye configuration and the other connected in an open delta configuration.

E. Provide loading resistors across secondaries.

2. Type and Design:

- A. Equipment will be located in line terminal cabinet and will be drawout type connected wye-wye, with current limiting primary fuses, secondary fuses, and necessary primary and secondary disconnecting devices and connections. Transformers shall be designed and constructed in accordance with ANSI C57.13.
- B. Surge arresters to be metal-oxide station type, General Electric Tranquell or Ohio Brass Dynavar.
- C. Furnish complete NEMA 2 steel enclosure cubicle with floor plate for above equipment with necessary primary and secondary connections, wiring, terminal blocks, and insulator supports and mounted on I-beam base so as to be self-supporting when resting on concrete floor or foundation.
- D. Furnish flanged connection with seal-off bushings at equipment enclosure and non-segregated bus extension to generator terminal enclosure.
- E. Furnish a ground bus at least 1 inch by ¼ inch cross section to the full width of each enclosure. Furnish connector for 250-MCM copper cable at each end of each ground bus.
- F. Arrange for entrance of external secondary circuit wiring from below.
- G. Surge capacitors and transformers shall not contain any PCB insulating fluid.

GENERATOR NEUTRAL GROUNDING EQUIPMENT:

- 1. Ratings:
 - A. As recommended by Contractor
 - B. Voltage as required, 60 Hz, 110-kV BIL
- 2. Grounding Resistor:

- A. Sized for high resistance ground system
 - B. Voltage rating suitable for connection to 220-volt transformer secondary
3. Type and Design:
- A. Transformer to be sealed dry type 300°F rise
 - B. Resistor to be cast-grid or stainless steel type
 - C. Furnish steel enclosure for housing transformer and resistor, with full height, hinged access doors, floor plate, and I-beam base so as to be self-supporting when resting on concrete floor or foundation. Provide adequate ventilation louvers in enclosure
 - D. Include wiring to terminal block in terminal compartment or cabinet for remote relaying connections, arranged for wiring entrance from above
 - E. Furnish connectors on transformer terminals and other provisions for connection of cable from generator neutral terminals, and for two connections to station ground grid by 250-MCM copper cable

GENERATOR TERMINAL ENCLOSURE:

- 1. Furnish one terminal enclosure.
- 2. Construct enclosure of heavy-gage sheet aluminum with internal stiffeners as required for rigidity.
- 3. The enclosures and/or the terminal attachment flanges at the top, should be able to accommodate an approximate construction variation in the calculated bus centerline-to-terminal vertical and horizontal distances of plus or minus 3/4 inch.
- 4. Construct with large removable access covers to permit removal and replacement of the disconnect links at the main terminals.

ACCESSORIES:

- 1. Provide generator with at least six stator temperature detectors of resistance

type, 100 ohms at 77°F, and at least two temperature detectors to measure cooling air inlet and discharge temperatures wired to terminal box.

5.2.8 Heat Recovery Steam Generator (HRSG) System

Contractor shall provide two (2) complete and functional HRSGs including all materials and labor required to design, fabricate, install, startup, and test the HRSGs. The HRSGs shall be a three pressure, natural circulation, water tube type designed for gas turbine exhaust. Each HRSG shall be complete with inlet ductwork from combustion turbine exhaust connection, including expansion joint, HRSG exhaust duct, and exhaust stack.

The HRSG process design concept is illustrated in Heat Balances and Conceptual Process Flow Diagrams, Appendix D. The HRSG shall be designed and constructed in compliance with the ASME Boiler and Pressure Vessel Code, Section I and NFPA 85.

The Scope of Supply shall include but not limited to the following:

1. Two complete modularized Heat Recovery Steam Generators
2. Inlet ductwork from combustion turbine exhaust, with expansion joint including gasket, bolts and nuts.
3. HRSG exhaust duct with expansion joint, including gaskets, bolts and nuts.
4. Individual Exhaust Stacks with test ports and CEM monitor ports
5. Motor actuated stack dampers
6. Internally insulated HRSG casing with complete liner.
7. Triple pressure HRSG with HP, IP, & LP drums, superheaters, evaporator and economizer sections, superheater attemperators, reheater attemperators.
8. Complete Duct burners system including all required piping, valves, instruments and complete PLC based burner management system. (Contractor option). All external duct burner fuel piping shall be insulated and heat traced.
9. Selective catalytic reduction (SCR) system, including vaporization skid, piping, valves instrumentation, ammonia injection grid and catalyst, also CO

catalyst

10. HP, IP, and LP Drum end enclosures which shall be heated and ventilated.
11. LP economizer recirculation pumps, valves, piping and temperature control system.
12. Galvanized access platforms, ladders and stairways. Ladders shall be located on one side of the HRSG with platforms and stairways located on the opposite side.
13. All structural steel supports to grade for ductwork and stack, as required.
14. All vents, drains, Blowdown, chemical feed connections.
15. All Steam safety valves with silencers vent piping to meet noise requirements specified in Section 1. Vents to be a minimum of 15 ft above the highest platform.
16. All safety valve above seat drains and drip pan drains shall be routed to a safe area.
17. Each heat transfer section shall be completely drainable and ventable. All valves that must be opened or closed as a part of startup, shutdown or transient conditions shall be power operated. All other vents & drains shall have manual valves. Drain valves shall be located at grade.
18. Continuous and Intermittent blowdown piping and power operated valves. Blowdown system shall not be a cascading system. Blowdown shall be routed to dedicated blowdown tanks for each HRSG.
19. Sample connections shall be provided for the water and steam from the HP, IP, and LP steam drums, reheater outlet, LP economizer inlet, and LP economizer outlet.
20. All piping between equipment and components furnished with the HRSG.
21. Temperature test connections (including thermowells) shall be provide for monitoring temperature of water inlet and outlet of each heat transfer sections.
22. Two (2) valved test connections on HRSG gas-side between each heat transfer section.

23. Stainless steel chemical feed connections with check and isolation valves for the HP and IP steam drums.
24. Complete set of all controls and instrumentation including, but not limited to, steam flow elements, temperature well, thermocouples, and transmitters.
25. Each HRSG shall be provided with a monorail and powered hoist and trolley with a stainless steel cable, rated for routine maintenance, and installation and removal of SCR catalyst.
26. Technical advisors for field installation and erection, finish painting, boilout, hydrostatic testing, startup and testing of the HRSG, SCR system and all auxiliaries, including all electrical raceways, cables, and any other equipment or special accessories and services required for a complete installation.

Each HRSG shall be capable of a full range of plant continuous operation between each of the following cases, at the design ambient temperature ranges:

1. 50% CTG load, single unit operation
2. Base CTG load with maximum duct firing, single unit operation
3. 50% CTG load, two unit operation
4. Base CTG load with maximum duct firing (if provided), two unit operation

5.2.8.1 General

All portions of the heat recovery steam generator shall be drainable. Provide drain system sized such that the drum, economizer, superheater, tubes, headers and piping can be drained in a maximum of 2 hours. Vents shall be provided on all sections of the HRSG. All high pressure vents that must operate during normal start-up and/or shutdown shall include silencers. Design for adequate circulation through all tubes and heating surfaces to prevent overheating of any area under any load and all operating conditions. HRSG shall be designed to allow operation with a floor pressure of 750 psia at all operating conditions (including 1x1 operation) with the CTG at 50% load, HRSG

unfired, and with the CTG at base load, maximum HRSG firing and power augmentation. All safety valve vents shall have silencers.

5.2.8.2 Pressure Parts

Design all pressure parts for safe operation at the outlet pressure specified at all loads. Provide for expansion and contraction so that tube alignment and spacing is not affected. Furnish airtight seals as required to prevent leakage.

Provide all necessary connections for chemical cleaning operations and access to headers for tube flushing, including access through casing and insulation.

All evaporator or economizer tubes shall be electric resistance welded and shall conform to the requirements of the ASME Boiler and Pressure Vessel Code. All reheater and superheater tubes shall be seamless drawn and shall conform to the requirements of the ASME Boiler and Pressure Vessel Code. Tubes shall be extended-surface type with continually welded fins. HRSG tubes shall be a minimum wall thickness of 0.105 inches with a 0.001 Hr-ft² °F/Btu fouling factor on both the gas side and the steam side. Tube arrangement shall facilitate cleaning and inspection without cutting of pipe. For inspection purposes, one turn in each coil shall be provided with a flanged inspection port. There shall be no more than 7 fins per in. Fins shall have a thickness of at least 0.060 inches, and shall be no more than 3/4 in. high. Fin connection to tubes shall utilize continuous high frequency welds. Provide baffles and tube supports as required to prevent acoustic vibration of tubes. No vaporization of feedwater shall take place within the economizer tubes throughout the entire operating range. Tubes shall be arranged for ease of removal and replacement of an individual tube with a minimum of disturbance to all other tubes.

Fin materials shall be as follows:

1. Carbon steel for fin tip temperatures up to 800° F.
2. Material similar to ASME 409 SS for fin tip temperatures up to 1000°F.
3. Material similar to ASME SA 213 Grade TP304 or TP316 for fin tip temperatures up to 1500°F.

Tube materials shall be carbon steel for tube temperatures up to 800°F and ASME SA213 Grade T22 for tube temperatures up to 1000°F and ASME SA213 Grade T91 for tube metal temperatures greater than 1000°F.

Superheater shall be designed to provide for uniform distribution of steam at all loads. Pressure drop shall not exceed 5% of maximum steam pressure at maximum steam flow, without Owner approval.

5.2.8.3 Boiler

Design for adequate circulation through all tubes and heating surfaces to prevent overheating of any area under any load and all operating conditions.

Tubes shall enter a drum or header normal to its surface. Hillside connections on headers are an acceptable alternative. The tubes shall be designed and arranged to provide for natural circulation in the proper direction at all loads.

Headers shall be seamless drawn steel pipe or fabricated from formed steel plate with welded construction. Headers shall have seal welded plug-type handholes, welded capped inspection nozzles, or other type as approved by Engineer, as required for inspection. Inspection handholes or nozzles shall be in accessible locations.

Boiler lower drains shall be provided with chemical-cleaning connections.

Connections for use by Owner shall be welding connections conforming to ANSI/ASME B16.25.

If headers are within the gas stream, they shall be designed as heat absorbing surfaces and shall not be insulated. Headers shall be adequate for the gas temperature encountered without allowance for internal steam cooling. Lower headers shall allow for steam pegging to maintain higher temperature when the unit is off line.

Provide drums and headers with nozzles as required for vents, drains and instruments. Nozzles shall extend beyond the header insulation; size and weld-end preparation of nozzles for Owner's connection shall be subject to the approval of Engineer.

External casing shall be gas-tight, continuously seal welded construction and provided

with packing at all piping penetrations and expansion joints. Construct casing of a minimum of ¼ inch thick A-36 carbon steel. Continuously weld all external stiffeners to the casing. Casing stiffeners shall be evenly spaced, horizontal or vertical, resulting in a uniform pattern and subject to approval by Owner. Provide 18 inch x 24-inch minimum bolted and gasketed access doors upstream and downstream of each tube bundle on both sides of the HRSG, in each transition, and as required to provide complete access to all components for maintenance and inspection.

Maximum bundle depth for all bundles shall be 12 tubes. Minimum access space between bundles shall be 24 inches. Individual tube bundles shall have provisions to facilitate repairs to the tube and header areas without cutting into adjacent tube bundles.

Bends, tees, elbows and downstream straight pipe sections in HRSG areas at high risk for flow accelerated corrosion (erosion-corrosion) shall be fabricated from material containing at least 2.25% chromium. HRSG design shall include proven features to prevent LP erosion/corrosion (due to flow acceleration) and shall be subject to Owner approval.

Ceramic insulation shall be used for all insulated portions of the HRSG (no mineral wool). The entire interior surface of the HRSG shall be lined, from the combustion turbine exhaust flange to the base of the exhaust stack, with steel liners, as follows:

Location	Temperature	Material	Thickness (BWG)
Walls	Up to 700°F	Carbon Steel	12 Ga.
Roof	Up to 700°F	Carbon Steel	12 Ga.
Floor	Up to 700°F	Carbon Steel	12 Ga.
Walls	701°F to 1200°F	TP 409 SS	16 Ga.
Roof	701°F to 1200°F	TP 409 SS	16 Ga.

Floor	701°F to 1200°F	TP 409 SS	12 Ga.
Walls	1201°F to 1400°F	TP 304 SS	16 Ga.
Roof	1201°F to 1400°F	TP 304 SS	16 Ga.
Floor	1201°F to 1400°F	TP 304 SS	12 Ga.

Non-steaming economizers shall be provided. Suitable recirculation piping loops shall be provided to maintain sufficient flow through the economizers to prevent steaming during startup of the HRSG. Feedwater and regulating valves shall be configured to provide reliable performance while operating at reduced flow.

The HRSG exhaust stack shall be of self-supporting, carbon steel construction designed and constructed in accordance with ASME/ANSI STS-1. Corten is not acceptable. The required exhaust stack top elevation shall be based on the output of the air permitting process. Exhaust gas sampling and other stack design provisions shall meet all EPA requirements and air permit requirements. The minimum stack gas temperatures and velocity shall meet all permit requirements over the full range of operation. Provide a davit for hoisting tools and test equipment. Provide 120V and 220V single-phase convenience outlets for power tools and test equipment at all stack platforms. Provide lightning protection to minimize potential for personnel injury, structural damage or equipment damage. Provide a minimum of one access door on lower stack breaching to facilitate access for maintenance and inspection. Each exhaust stack shall be provided with a motor operated damper. Provide stack P-trap drain to remove rainwater when stack is not in operation. Each stack shall be designed with a 1/8-inch corrosion allowance for the bottom ten feet of the stack and 1/16-inch thereafter, or be provided with a stainless steel liner.

Piping materials for the HRSG shall be manufacturer's standard, based on appropriate design codes and standards.

Drains shall be provided at various parts of the HRSG for complete water removal to facilitate maintenance. The drain system shall be designed to drain all water from the

boiler to protect against freezing during periods of sustained outages and low ambient temperatures. All HRSG drain connections shall have two globe valves in series and the second root valve shall be located at grade level or at a location having permanent access. All drains shall be piped to either a condensate flash tank or a turbine drains tank. Casing drains shall be provided to continuously drain any condensation from exhaust gas. Vents shall be provided at accessible locations on the HRSG to allow air to enter to facilitate drainage prior to maintenance. Provisions shall be made for venting air during filling and startup. Provisions shall also be provided on the steam drums for nitrogen blanketing during extended shutdowns to minimize corrosion. The nitrogen connections shall be provided at grade. Vents used for plant startup shall be silenced to conform to plant noise permits specified in Section 1.

Design HRSG steam side components to be fully drainable and include valved drains on each component accessible from outside the unit. Provide drain system sized such that any single pressure level, to include the drum, economizer, superheater, tubes, headers and piping, can be drained in a maximum of 8 hours.

Provide isokinetic steam sampling nozzles per ASTM standard D1066 for measuring steam purity.

HRSG shall be designed with pinch points no less than 13°F.

Design economizers such that steaming does not occur during normal operation. Steam venting will be allowed at part load conditions, provided provisions are included in the system for venting this steam to the corresponding steam drum. Venting shall be controlled with a motor operated vent valve

Pressure Drops:

1. Pressure drop for the HP drum to the HP superheater non-return valve shall not exceed 6% at maximum steam flow.
2. Pressure drop from the HRSG cold reheat inlet connection to the HRSG hot reheat outlet connection shall not exceed 4% at maximum steam flow.
3. Pressure drop from the IP drum to the IP superheater outlet connection shall not exceed 6% at maximum steam flow.

4. Pressure drop from the LP drum to the LP superheater outlet connection shall not exceed 6% at maximum steam flow.
5. Pressure drop from the HP economizer inlet to the HP drum shall not exceed 2% at maximum steam flow.
6. Pressure drop from the IP economizer to the IP drum shall not exceed 2% at maximum steam flow.
7. Pressure drop from the Feedwater Preheater to the LP drum shall not exceed 2% at maximum steam flow.

The attemperator shall be located and designed so that under the most adverse operating conditions the temperature of the steam leaving attemperator-mixing zone will exceed the saturation temperature by at least 25°F.

Provide structural and miscellaneous steel required to frame and support the steam generator and all component parts and equipment. Provide structural steel supports for flues, ductwork, transitions, casing and stack as required. The structural steel frame shall be designed to take all piping loads of those pipes connecting to the boiler, within the boiler frame area.

The transition duct angle shall not exceed a 45° angle between floor and roof of transition. Alternate proven configurations shall be subject to approval by Owner.

5.2.8.4 Drums

Size steam drums to provide stable operation under all load conditions including start-up, shutdown, and load variations. Size high pressure and intermediate pressure steam drums to provide a minimum of three (3) minutes of storage with no incoming water at the fired steaming rates between the normal water level and Low Low Trip points. Contractor shall size low-pressure steam drum to provide a minimum of five (5) minutes of storage, with no incoming water, at the fired steaming rates, between the normal water level and Low Low Trip points. HRSG gas side expansion joints shall be of a flanged, insulated design.

Drums shall be fusion-welded throughout with all welds made, tested, radiographed and

stress-relieved in strict accordance with the ASME Boiler and Pressure Vessel Code, and approved by a recognized boiler inspection and insurance company.

The steam-separating drum shall be equipped with the following internals:

1. A means to assure even distribution of feedwater throughout the drum length and equal distribution of flow to the downcomers.
2. Alloy steel chemical feed piping.
3. Steam and water sample piping.
4. Steam deflecting baffles.

Vane- or centrifugal-type steam-cleaning devices designed to ensure a minimum of pressure drop, to provide maximum free space in the drum, and to limit carryover of impurities into the superheater to the level required by the steam manufacturer and in accordance with ABMA guidelines.

All drum internals shall be fabricated in convenient lengths for removal from the drum through the manholes.

Each end of the steam-separating drum shall have a manhole not smaller than 12 in. by 16 in. with a machined seat and forged steel cover hinged to swing inward. Manholes shall be complete with gaskets, arbors, and bolts. Furnish one extra set of gaskets to be turned over to the Owner.

Nozzles shall be fusion-welded to the drum, and the welds shall be stress-relieved.

5.2.8.5 Piping

All pressure parts of the boiler, superheater and economizer shall be connected together as necessary to meet the following requirements:

Provide piping and connect to the steam generator pressure parts:

1. Nitrogen blanketing connection (single connection unless multiple connections are required to blanket entire steam generator).

All necessary piping, valves, fittings, constant force piping supports, and insulation which, when combined with the above items, will constitute a complete steam generating unit. This shall include, but is not limited to, the following:

1. Piping from economizer outlet to steam drum.
2. Double shutoff valves at all external connections to the steam generator pressure parts, whether connected to by Owner or Contractor. The only exceptions to this requirement are the following connections:
 - a. Economizer Water inlet
3. Safety valve connections - Contractor shall furnish safety valves as required by ASME Boiler and Pressure Vessel Code. All safety valves shall be installed in piping furnished by this Contract.
4. Safety valve exhaust piping to a point 10 feet above the elevation of any platform within 25 feet.
5. All vent stacks to a point 10 feet above elevation of any platform within 25 feet.
6. All drain piping and the drum blowdown piping to a point two feet above grade elevation. Location of terminations shall be subject to Owner's approval.

Provide pipe supports for all piping furnished. Supports shall be designed to support the weight of all piping furnished by this Contract.

HRSGs shall be provided with provisions for sampling steam and boiler water, and provisions for blowdown and chemical injection to control dissolved solids in the HRSG operation. The HRSGs shall also be provided with the capability for chemical cleaning after construction.

Drains and vents shall be sized, with remotely operable valves, to allow for frequent starts and short start times and to prevent thermal quenching.

Each HRSG shall be controlled by the plant DCS and shall operate without local

attendance. Visual monitoring of the drum levels shall be provided in the control room. The HRSG controls shall comply with all code requirements and shall operate to prevent injury to personnel and damage to the HRSG and other equipment, under all operating and abnormal conditions.

The maximum exhaust gas pressure drop at ISO conditions between the gas turbine discharge and the stack exit, including SCR and CO catalyst, shall be less than 17 inches of H₂O.

Contractor shall provide minimum of 3 feet clear wide access platforms on the HRSG to facilitate access all around the steam drums and to all instrumentation and elevated manual valves on the HRSG system. Drum level support steel shall not include vertical bracing. Drum end enclosures shall be provided. Only the exhaust stack shall rise higher than 12 inches above the enclosure. Provide a minimum of one set of stairs to access all levels of the platforms and provide alternate egress as required by OSHA.

HRSGs and piping systems shall be designed to proportionally control the cold reheat steam flow to the high pressure steam flow to balance the cold reheat flows between multiple units at all operating conditions.

Contractor shall provide a recirculation system to maintain a minimum stack gas temperature above acid dewpoint under all operating conditions. The condensate temperature setpoint shall be selectable in the DCS.

Contractor shall provide flanged EPA test ports on the stack sized and located in accordance with the air permit requirements. Provide 5 feet minimum wide, full 360° access platforms with ladders to facilitate access to the sample ports. Provide FAA Aviation Lights as required for the stack.

Contractor shall insulate the steam drums and the entire casing of the HRSG through the low pressure economizer section to maintain an external surface temperature at or below 140°F at all operating conditions. The insulation thickness design will be based on an air velocity of 5 mph and an ambient air temperature of 100°F or OSHA requirements, whichever is lower. Provide ventilated and heated drum end enclosures or other suitable protective devices to prevent freezing of the drum trim piping when the HRSG is not in operation and the ambient temperature is at the absolute minimum for

the site. The insulation shall be certified asbestos free by the manufacturer.

Contractor shall provide all specialty valves and instrumentation required by the applicable ASME code and including, but not limited to, the following for each HRSG:

1. Drum pressure safety valves with silencers on each steam drum
2. Superheater pressure safety valves with silencers on each superheater
3. Start-up vent valves with silencer and pneumatic operators on each pressure system
4. Automatic continuous blowdown regulating valves with operators on each evaporator system.
5. Intermittent blowdown stop valves with power operator on each evaporator system.
6. Continuous drum blowdown stop valve with power operator for each drum
7. Feedwater stop valves with power operators on each evaporator system
8. Drum level control valves with operators on each evaporator system
9. Superheater drain valves with power operators on each superheater section
10. Steam stop valves with power operators on each outgoing steam line
11. Steam stop-check valves on each outgoing steam line
12. Water column, with probe type alarms: HH, H, L, LL on each drum
13. Water gauge glass on end of each drum
14. Two remote drum level indicators for each drum (one located in control room and one located at the drum level control valve bypass station)
15. Three remote drum level transmitters on each drum
16. Drum pressure transmitters on each drum

17. Drum pressure Indicators on each drum
18. Drum pressure switch on each drum
19. Four drum surface thermocouples for each drum
20. Feedwater thermocouple with well on each drum feedwater line
21. Feedwater temperature indicator with well on each drum feedwater line
22. Feedwater pressure indicator on each drum feedwater line
23. Economizer inlet and outlet thermocouple with well for each economizer
24. Economizer inlet and outlet temperature indicator with well on each economizer.
25. Superheater steam outlet temperature indicator with well for each superheated steam discharge line
26. Superheater steam outlet thermocouple with well for each superheater steam discharge line (two on high pressure steam)
27. Superheater steam outlet pressure indicator for each superheated steam discharge line
28. Cold reheat thermocouple with well
29. Cold reheat pressure indicator
30. High pressure steam and reheat steam attemperators with control valves and actuators
31. Attemperator inlet and outlet thermocouple with well for each attemperator
32. Attemperator inlet and outlet temperature indicator with well for each attemperator
33. Recirculation pump inlet and outlet pressure indicator
34. Recirculation pump outlet thermocouple with well

35. Low pressure economizer inlet thermocouple with well
36. CTG exhaust gas temperature indicators with well (two at inlet transition and one after each component section)
37. CTG exhaust gas absolute pressure indicators (one at inlet transition and one after each component section)
38. Power operated vent and drain valves.
39. Instrument isolation valves, including root valves for all pressure gauges and transmitters.

5.2.8.6 Ductwork, Casings and Insulation

Provide all equipment, materials and labor necessary to encase and insulate the steam generator unit.

Casings, transitions, and ductwork shall be internally insulated.

Outer casing shall be at least 3/16-inch and shall provide a gastight seal. All field joints in the outer casing shall be designed to be seal welded.

All casings, transitions, and ductwork shall be provided with external stiffeners and shall provide a gastight seal at 1.5 times the maximum operating pressure. Penetrations shall be sealed to prevent leakage.

Provide drain connection in bottom of casing to allow for water washing. Drain shall be 2-inch-minimum size, provided with a cap.

Inner casing liner shall be stainless steel. Design inner casing with adequate allowances for expansion, and to protect insulation from gas flow.

Provide gas distribution devices necessary to assure even distribution of gas across heat transfer surfaces.

Casing, insulating, and lining materials shall have been proven acceptable in units of comparable capacity, temperature, and pressure.

5.2.8.7 Insulation

Insulation and other materials shall be in strict compliance with the applicable ASTM standard specifications. They shall be certified asbestos-free by the manufacturer.

Insulation shall be designed so that the outside surface temperature measured at any point (including hot spots) will not exceed 140°F when the ambient air temperature is 100°F 5 feet away from skin or insulation (while the steam generator is operating), with an outside surface air velocity of 5 mph. Insulation thicknesses shall be reviewed and approved by Owner.

1. Insulation shall be ceramic fiber suitable for design conditions conforming to ASTM C533 or Engineer-approved equal.
2. The binder used in the insulation shall show no deterioration at 100°F above the actual operating temperature where the material is applied. Binders shall be water repellent.
3. Minimum density of any blanket or block insulation shall be 7 pounds per cubic foot.

5.2.8.8 Access

Provide Class 1 access to all areas requiring access during operation, or for normal day-to-day inspection and maintenance, including the following:

1. Observation ports.
2. Lubricated equipment.
3. Instruments.
4. Valve operators.
5. Each end of boiler drums.

Access doors shall be standard cast-hinged doors closed with a strong back arrangement. Provide ladder rung as a handhold above access doors, both on interior and exterior. Access doors shall be a minimum size of 14"x18".

Provide access lanes between each section of the steam generator.

Contractor shall provide expanded metal personnel protection shields or other suitable personnel protection devices at each stack access platform and anywhere else on the HRSG systems where temperatures exceed OSHA limits. Personnel protective devices shall be provided in accordance with applicable OSHA standards.

5.2.8.9 Duct Burners

Supplemental duct firing may be included in Contractor's design to maximize steam generation. At maximum duct burning each HRSGs shall be capable of supplying high-pressure superheated steam to the steam turbine at throttle pressures and temperatures as dictated by Contractor's design.

If included, duct burner design shall meet the following criteria:

1. The duct burners shall be a low-NO_x design that meets the requirements of the project air permits over the full range of plant operating loads and ambient conditions.
2. Superheated steam temperature spread across the HRSG shall not exceed 70°F at any point. Distance from duct burner to first row of tube bundles shall not be less than 15 feet.
3. Tube metal temperature shall not exceed the limits specified by the HRSG manufacturer at any operating condition (fired or unfired). Instrumentation shall be provided for monitoring tube skin temperature and flue gas temperature downstream of the duct burner. Skin temperatures shall be measured throughout the HRSG cross-section, including tube sections located outside of the HRSG casing. Flue gas measurement taps shall be provided at every 10 feet (vertically) from the bottom of the HRSG casing, approximately 3 feet in from the sides of the casing on both sides of the HRSG.
4. Provide a minimum of two view ports per burner (one on each side) in HRSG casings to allow viewing the duct burner flames.
5. Duct burner runner controls, scanners, and view ports shall be accessible

from the platforms without requiring ladders or scaffolding.

6. Duct burners shall not utilize air augmentation.
7. The minimum oxygen level in the duct burner exhaust gases shall not be less than those specified by the burner manufacturer.
8. The duct burner control system shall be fully integrated with the plant DCS.
9. The duct burner shall provide a stable flame over a 10 to 1 automatic turndown range.
10. Provide automatic isolation valve for each burner runner (elevation).
11. Duct burner flame scanners, pilot burners, and pilot igniters shall be provided. Include two 100% scanner cooling / purge air blowers each with an inlet air filter and silencer. Two flame Scanners shall be supplied per each burner.
12. Include a Burner Management System (BMS) with a programmable logic controller, factory assembled, wired, and tested, including all safety interlocks and indicators as required by the applicable codes. Provide BMS system designed for remote firing rate signals to be supplied from the main plant DCS controller. The PLC shall be in an air-conditioned enclosure.
13. The fuel gas manifold in the turbine exhaust gas flow shall be type 304 stainless steel.
14. Provide a strainer and a PRV for conditioning of fuel gas supply to the burners. PRV shall be located at grade or platform accessible.
15. Duct burner shall be located in a cross-section of the ductwork and the duct burner shall distribute fuel gas evenly across the duct.
16. Duct burner shall be located to prevent impingement of flames on the tube surfaces.
17. Burner elements shall be designed to allow for thermal expansion and to prevent acoustic vibration.

18. If multiple burner elements are required, provide distribution headers for fuel gas, igniter gas, and scanner cooling air.
19. Duct burner frame shall be insulated for protection from flue gas temperatures.
20. Burner ignition shall be completely automatic.
21. Ignition system shall include gas pilot burner, electric ignition electrode, electric ignition transformer, two power-operated shutoff valves, one manual shutoff valve, pilot gas regulator and strainer.

The duct burner installation shall meet all requirements of NEC, NFPA, Factory Mutual, and local codes.

5.2.8.10 Selective Catalytic Reduction System

A selective catalytic reduction (SCR) system shall be incorporated into each HRSG to meet the NO_x and ammonia slip emission limits specified in the air permit over the full range of operation from Peak Load to Minimum Load and the full range of ambient temperatures. The SCR system design and location shall include consideration of operating temperature requirements for proper catalyst performance, flow straightening devices, ammonia injection grids, and mixing zones. SCR shall be capable of responding in real time to allow for load level changes, up to maximum ramp rate, up or down, so as to maintain permit limits for hourly averages.

SCR system casing shall be of the same construction and cross section as the HRSG casing. Provide access manways and catalyst loading openings in the casing sufficient to facilitate removal and installation of the catalyst modules without the need for cutting or welding of any casing components. Include and integrate a monorail and hoist system to facilitate installation and removal of the catalyst sections. Hoist system shall extend out over open grade for lifting and setting materials from maintenance carts of pallets.

Include space, frame, and design consideration for 50% additional catalyst in the SCR system.

Provide instrumentation necessary to monitor catalyst performance. Provide NO_x

sample ports upstream of the SCR Catalyst.

Contractor shall obtain from SCR catalyst Vendor a warranty that the installed catalysts will provide NO_x emissions reduction from the guaranteed combustion turbine emissions, including contribution from the duct burners (if provided), down to the permitted HRSG stack emissions for a minimum period of thirty-six (36) months after the plant Substantial Completion Date, or 22,500 fired hours of operation, whichever comes last.

Testing penetrations consisting of 2 ½ inch pipe connections shall be provided to permit performance testing of the system. The test ports shall have blind flanges. The design and configuration of the test ports shall allow traverse testing before and after each layer of catalyst in a grid arrangement. Contractor shall provide access to the test locations consisting of walkways, platforms and ladders.

The SCR catalyst shall be of the low dust type. The catalyst shall be designed to minimize pressure loss. The direction of gas flow through the catalyst shall be horizontal.

The catalyst shall be either a homogenous extruded material or the catalyst surface shall be supported on a metallic or ceramic monolithic base material. The catalyst modules shall not be subject to delamination or permanent deformation of the catalyst or support material due to stresses induced by the seismic conditions, vibration, pressure and thermal conditions or combinations thereof.

The catalyst shall be resistant to poisoning by trace elements. The catalyst shall be resistant to water and abrasion.

The volume of catalyst supplied shall be designed to control ammonia slip to the values guaranteed without requiring cleaning, regeneration, or replacement during the performance guarantee period.

The catalyst shall be of modular design to facilitate installation and removal of the catalyst. The catalyst modules shall be the maximum practical size to facilitate and minimize field maintenance. Any special tools required to facilitate the removal or installation of catalyst modules shall be provided. Any special tools or handling fixtures for the proper handling or unloading of the catalyst modules from a truck or rail car shall

be provided.

Contractor shall provide catalyst coupons/holders. In order to monitor catalyst life and performance, a minimum of 10 test coupons shall be provided and installed in the catalyst beds as, and where, recommended by the catalyst manufacturer. Additional catalyst coupons shall also be furnished for future reference performance and composition analysis. Each catalyst coupon shall be labeled with a serial number. All catalyst coupons shall be from the same lot as the installed catalyst. These samples will be tested to evaluate catalyst activity and physical properties as the catalyst ages.

The catalyst modules shall include sealing frame and frame steel to improve the ease of catalyst replacement and installation. The frame materials shall be compatible with the catalyst material. The sealing system shall be designed to limit exhaust gas leakage past each layer of catalyst. The sealing mechanism and materials shall provide a service life equal to or greater than the catalyst.

5.2.8.11 Ammonia Injection Skid

Contractor shall provide a skid mounted aqueous ammonia (19%) injection system complete with all necessary equipment, including but not limited to mixers, blowers, motors, electric or side stream heaters, piping, all valves, vent and drain piping and instrumentation. Two (2) 100% capacity flue gas recirculation air blowers shall be provided as well as associated valves, control valves, and NH₃/air mixer for each skid. The critical components including, but not limited to, the dilution air fans and the electric heaters shall have an installed 100% spare on the skid. The heaters and blowers shall be designed for 100% of maximum flow of reagent to the ammonia injection grid.

5.2.8.12 CO Catalyst

Provide a CO catalyst system with each HRSG to meet the air emission requirements for CO and VOCs. The CO catalyst shall be designed and located in the HRSG to meet the requirements of the air permit over the full range of operation from Peak Load to Minimum Load and the full range of design ambient temperature.

Include space for 50% additional CO catalyst.

CO catalyst system casing shall be of the same construction and cross section as the

HRSG casing. Provide access manways and catalyst loading openings in the casing sufficient to facilitate removal and installation of the catalyst modules without the need for cutting or welding of any casing components. Include and integrate a monorail and hoist system to facilitate installation and removal of the CO catalyst sections. Hoist system shall extend out over open grade for lifting and setting materials from maintenance carts or pallets.

Provide instrumentation necessary to monitor catalyst performance. Contractor shall obtain from the CO catalyst Vendor a warranty that the installed catalysts will provide CO and VOCs emissions reduction from the guaranteed combustion turbine emissions, including contribution from the duct burners, down to the permitted HRSG stack emissions for a minimum of thirty-six (36) months after the plant Substantial Completion Date.

5.2.8.13 HRSG Erection

Work shall include the following:

1. All expert and common labor, rigging, blocking, scaffolding, tools, construction materials and supplies to remove the Equipment from cars, haul, store, protect, erect, and install all the material furnished complete in place.
2. Grout and grouting, shims, grout forms, and blocking.
3. Erection of structural and miscellaneous steel.
4. Erection bracing, temporary struts, ties, cables, temporary flooring, planking, and scaffolding as required for the erection of the unit.
5. Furnishing and installation of miscellaneous pipe hangers and supports for piping installed with the Equipment. Installation of nipples, valves, and safety valves.
6. Welding of piping supplied with the Equipment by manufacturer's procedures acceptable to Owner, including testing of welds where required by codes and all costs in connection with welder qualification tests.
7. Installation of trim, instruments, control devices, start-up thermocouples, and bearing thermocouples furnished as specified.
8. Installation of setting, insulation, and lagging, including supplying all materials as required for a complete installation.

9. Cleaning up, testing and placing into operation the Equipment, including attendance by manufacturer's service representatives during preliminary operation, testing, boilout, blowout, and cleaning as required to make necessary adjustments and perform work to make unit acceptable.
10. Inventorying and turning all spare parts over to Owner.
11. Inventorying and delivering all special tools and devices furnished as part of the Equipment to Owner in good condition after erection is completed.
12. Testing, adjusting boiler trim, including setting of safety valves under direction of valve manufacturer's representative.
13. Attendance for Owner's insurance inspector, including opening unit for inspection and as required.
14. Boiling out the unit.
15. Chemically cleaning the unit.
16. Steam line blowing.
17. Retouching of damage to shop prime and finished painted surfaces.
18. Protection of steam generator from freezing, including maintenance of temporary heating equipment.
19. Alignment of Equipment for smooth, trouble-free operation.
20. Preparation of Equipment and piping ready for external connections at terminal points.
21. Acceptance testing as specified.
22. Retightening flanges, valve bonnets, and repacking leaking valves.
23. Calibration of instruments and tuning of controls.
24. Disconnecting and reconnecting couplings for motor rotation check.

The installation of the Equipment shall be complete in all respects, to make the unit ready for commercial operation except for Owner's connections under other contracts. Provide Owner with copies of all data reports required by the ASME Boiler and Pressure Vessel Code and ANSI B31.1.

FIELD SUPERVISORS:

1. The services of erection supervisors shall be furnished to supervise and be

responsible for the complete and correct erection, assembly, and installation of the Equipment furnished under this Contract.

2. Supervisors shall report to the jobsite prior to the commencement of erection to plan and coordinate the Work, and be present during unloading, storing, hauling, erecting of all Equipment, and at such other times that his services are required as determined by Owner.
3. Supervisors shall keep Owner informed on the progress of the Work during erection and testing and coordinate work with Owner on any problems that will affect progress of the Project.

MANUFACTURER'S FIELD SERVICE:

1. Contractor shall include in the Bid the cost of the services of competent manufacturer's servicemen for field testing and placing in operation all electrical devices and safety valves for inspecting and placing in operation control systems provided.

GROUTING:

1. Furnish and place all grout required to erect and install the Equipment and machinery.
2. Except where otherwise specified by the Equipment manufacturer, grout all equipment and machinery with a nonshrinking grout.
3. Prepare and place grout in accordance with the manufacturer's written instructions.
4. Furnish and install grout forms. Grout forms shall be tight and shall be caulked as required to prevent leakage.
5. Chip back and clean foundation surfaces as required for proper clearances and to obtain proper bonding.
6. Grout bed shall have at least 2 inches of thickness for every four feet of horizontal grout flow required, and shall be as required to properly align and position the Equipment and machinery in accordance with the Equipment manufacturer's requirements.
7. Protect anchor bolt sleeves from freezing using methods approved by

Engineer. This requirement shall be Contractor's responsibility from the date the foundation is released to Contractor for his use until grout has been placed to prevent water from entering the sleeves.

8. Grout all anchor bolt sleeves, unless otherwise specified by the Equipment manufacturer.
9. Place grout under entire base plates, support plates, and bed plates. Drill grout vent holes if necessary.
10. Protect grout for at least 24 hours against rapid water loss. Maintain grout between 65°F and 80°F until cured. After grout has hardened for at least six hours, remove grout forms, remove excess grout to a neat trim line, and apply a coat of an approved curing compound. Care shall be taken to prevent the transmission of vibration from operating machinery and construction activities to the Equipment being grouted.
11. Unless otherwise directed by Equipment manufacturer's instructions, grout leveling and support shims and wedges in place with nonshrink grout. The shims and wedges shall be completely encased in grout.

WELDING:

1. Perform all welding as required for the installation of the structure, Equipment, and piping.
2. Welding rod shall be the best quality rod, suitably shielded, designed and made for use with the specific material to which it is applied, and shall conform to the latest ASME specifications or AWS D1.1. Rod used on alloy materials shall be ordered by ASME or AWS specification and chemical composition.
3. Provide welding rod drying ovens when required. The use of wet or moist welding rod will not be permitted.
4. Welding procedures shall be in accordance with the ASME Boiler and Pressure Vessel Code and the applicable portions of ASME B31.1. Structural steel welding shall be in accordance with AWS D1.1 and the AISC specifications.
5. All welders and welding operators shall be qualified as required by the

applicable codes. Submit three copies of qualification test records for each welder and welding operator. All costs for welders' qualification tests and certification shall be at Contractor's expense.

6. Heat treat welded joints in accordance with the ASME Boiler and Pressure Vessel Code and the applicable portions of ANSI B31.1.
7. All welds shall be inspected by the designated agencies as required by the various codes including radiography of welds where required by code. All costs for the required inspections and radiography shall be at Contractor's expense.
8. All welding shall be in accordance with the best modern practices to reduce distortion to minimum. Include tack welds and alignment clips, as required.
9. For P-91 and T-91 materials, Contractor shall submit special welding procedures and NDE to be used to avoid weld joint failures in the field and during normal operation.

ERECTION AND INSTALLATION OF PRESSURE PARTS AND PIPING:

1. Erect and install all pressure parts and piping in accordance with the applicable portions of the ASME Boiler and Pressure Vessel Code and ASME B31.1.
2. Erect pressure parts and piping true to line, facing, and position and without strain on pipe, fittings, and Equipment.
3. Make final weld in piping systems only after stress relieving all other welds, and after obtaining correct alignment.
4. Keep foreign matter out of tubes, drum, piping, and other pressure parts. Clean, blow out and sound all pressure parts to assure they are clear and clean.
5. Connections to rotating Equipment shall be disconnected as required for alignment checks. Correct any misalignment of the piping.
6. Erect and install hangers and supports as follows:
 - A. Install hangers, supports, and anchors as required to adequately support the pressure parts and piping.

- B. Adjust hangers as follows:
- (1) Prior to putting the Equipment and piping systems into service, remove travel stops, adjust all spring hangers to the correct cold load, adjust all solid hangers to correct position, and remove all temporary hangers used in erection and testing.
 - (2) After and during the time the Equipment and piping systems are being put into service, adjust all spring hangers for the correct hot load and align all hanger rods to the vertical position. Furnish and install additional hangers, sway braces, and bracing as required to stabilize piping systems.
- C. Field fabricate piping as follows:
- (1) Field fabricate and erect piping for miscellaneous systems and small pipelines.
 - (2) Field route small piping to avoid interference with other work and to provide a neat installation. Reroute and arrange as directed and as approved by the Engineer. Erect with off sets, fittings, unions, drip pockets, vents, drains, and hangers to make a complete installation.
- D. Retighten flanged joints as follows:
- (3) Retighten flanged joints in pipelines and on Equipment after being exposed to working temperature and pressure for a sufficient length of time to ensure that flanges and studs have reached a point of constant temperature, and have attained such changes in dimension as will take place.
 - (4) Where the operating temperature is 450°F or higher, retighten joints after 200 hours of service at operating pressure and temperature.
 - (5) Tighten pressure seal valve bonnet studs or spanner nut with torque wrench per manufacturer's instructions before start-up and after one temperature cycle.
- E. Make up flanged and threaded joints as follows:
- (1) Apply gaskets for low-pressure, low-temperature joints dry. Apply all other gaskets in accordance with the gasket manufacturer's instructions.

- (2) Use an antisieze compound to lubricate all flange bolt and stud-bolt threads and all threaded pipe joints, with the compound applied to male threads only. Antisieze compound shall be suitable for temperatures up to 1,000°F and shall be "Molykote G" or approved equal.
- F. Furnish and install unions in piping systems using screwed joints as follows:
- (1) Install in pipelines so lines may be broken for maintenance, valves may be removed and Equipment disconnected.
 - (2) Install in lines which are erected without unions and which, in the opinion of Engineer, cannot be properly maintained.
 - (3) Install dielectric unions wherever copper pipe is joined to iron or steel pipe or equipment. Install in positions which receive axial thrust only.

INSTALLATION AND APPLICATION OF BRICKWORK, REFRACTORY, INSULATION AND LAGGING:

1. Provide fire-resistant drop cloths and enforce their use to keep refractory and insulating materials off gratings, floors, structures, and Equipment not specified to be insulated.
2. Do not apply brickwork, refractory, insulation, and lagging over welded joints until Equipment has been hydrostatically tested.
3. Install and apply brickwork and refractory as follows:
 - A. Install clips or studs on Equipment as required to properly support and attach brickwork and refractory.
 - B. Thoroughly clean surfaces prior to installing brickwork and refractory to ensure secure bonding. Sandblast corroded surfaces where required.
 - C. Brickwork shall be installed complete with mortar and grout to form a continuous surface free of cracks and voids. Saw cut into special shapes where required to fit irregular areas. Grout and mortar mixtures shall be in strict accordance with the manufacturer's recommendations and instructions.
 - D. Refractory mixture and application shall be in strict accordance with

manufacturer's recommendations and instructions. Furnish all equipment required to apply refractory.

4. Apply insulation and lagging as follows:
 - A. Install insulation pins, clips, and studs on Equipment as required to properly support and attach insulation.
 - B. Store all insulating and lagging materials indoors. Protect materials from damage due to moisture, crimping, buckling, spotting, streaking, and similar causes.
 - C. Provide weather protection for all insulation materials during and after application until such time as the insulation is lagged and enclosed to form final weather protection.
 - D. Install all insulating materials in strict accordance with the manufacturer's recommendations, specifications and instructions, and as specified. Completely cover all surfaces to be insulated so there are no voids, cracks, or depressions. Adequately support insulating materials with wire mesh, expanded metal lath, and tie wires so that insulation will not shift, sag, or separate.
 - E. Provide laps, seals and flashing to make lagging weathertight. Seal all penetrations through lagging weathertight. Install lagging so ribs form a smooth unbroken line and so that water is not pocketed in the ribs.

EQUIPMENT AND MACHINERY ERECTION:

1. Erect and install all Equipment and machinery in strict accordance with manufacturer's instructions and as directed by the manufacturer's field representatives.
2. Meet the requirements of the manufacturer and/or his field representative for the means employed for doing the various classes of work, all tolerances in alignment and leveling, and the quality of workmanship for each class and stage of the Work.
3. Protect all Equipment, machinery and Materials against corrosion, moisture deterioration, mechanical injury, and accumulation of dirt or other foreign matter to include the following:

- A. Protect all bearings by field lubrication as required.
 - B. Keep all pipe and equipment connections closed until ready for connection.
 - C. Cover Equipment, machinery, and Materials with suitable covers and provide temporary heat where required.
 - D. Spot paint all Equipment and machinery where the shop coat of paint has been damaged.
4. Provide access to motors in storage for the power wiring contractor to connect temporary power to the space heaters and to megger the windings.
 5. Cover and protect Owner's concrete and floor surfaces from scarring and oil spots.
 6. Furnish and install cinch anchors, grout, shim material, and the miscellaneous steel necessary for brackets, anchors, or supports required in the installation of the Equipment and machinery.
 7. Replace any gaskets damaged during storage, inspection, cleaning, or placing into service.
 8. Accomplish all field machining that might be required to fit Equipment and machinery together or to install Equipment and machinery.
 9. Align Equipment as follows:
 - A. Make all measurements and determine elevations to position and align Equipment and machinery in accordance with the manufacturer's requirements.
 - B. Shim equipment, machinery, and motors as required to align Equipment and machinery at normal operating temperatures.
 - C. Align motors to Equipment and machinery with motor rotor at the mechanical center.
 - D. Tighten anchor bolts to proper stress level using torque wrench or by the turn-of-nut method.
 - E. Following initial alignment, pull and store coupling bolts, remove all shipping restraints, make all required inspections and checks, and tag motor as ready for rotational checks. Rotational checks will be performed by Contractor and witnessed by Owner.

- F. After all connections are made and the Equipment and machinery is prepared for initial operation, set clearances as required and verify alignment. Have final alignment check and makeup of couplings observed by Owner.
 - G. Dowel motors to base plates after hot run in.
10. Lubricate Equipment as follows:
- A. Prior to initial operation of the Equipment, clean and flush bearings and lubricating oil systems until clean. Circulate oil, vibrate lines, clean strainers, and replace filters in accordance with manufacturer's instructions. Drain systems, wipe out reservoirs, and clean as required. Contractor shall furnish all flushing oils.
 - B. After flushing fill all lubricating systems with oil and lubricate all Equipment with oil and lubricants provided by Contractor. Contractor shall provide a lubricant list for all Equipment using lubricants from Owner's supplier.

ERECTION OF FLUES, DUCTS AND PLATE WORK:

1. Furnish all erection bolts, clips, angles, and lugs required to align and position sections for welding.
2. Accurately align and position sections for welding and perform all welding in a manner to prevent warping and distortion.
3. Accurately align damper frames and install dampers without distortion. Adjust dampers for free operation and tight shutoff.

FIELD TESTS:

All field tests recommended by the manufacturers of the various items of Equipment shall be made by Contractor. Contractor shall provide all temporary testing equipment required.

1. Hydrostatic Tests:
 - A. After erection, all pressure parts and piping systems shall be given a hydrostatic test at a pressure 50% in excess of the design working pressure in accordance with the ASME Boiler and Pressure Vessel Code and the applicable portions of ASME B31.1.

- B. Contractor shall provide cold water for the tests and suitable disposal facilities for wastewater after tests are complete. Contractor shall provide all piping, hoses, and drain lines to deliver water for testing and for disposal of water after testing. Water for hydrostatic testing shall be heated to a minimum temperature of 70°F. Contractor shall provide heat exchangers, chemicals, circulating pumps, and all piping required to heat and treat cold water to the proper temperature and quality.
 - C. Furnish all necessary equipment and materials required for testing including pumps, gauges, temporary blank-off plates, gaskets, anchors, and bracing required to conduct tests.
 - D. Furnish and install an accurate pressure recorder and continuously record the pressure during the complete hydrostatic test.
 - E. Immediately repair or replace all tested Material or Equipment found leaking or defective.
 - F. Protect plant equipment and materials from damage resulting from leaks during testing. Protect instruments and appurtenances as required during testing and repair or replace if damaged. Clean fluid from leaks immediately after contact.
 - G. Provide all required attendance for Owner's insurance inspector, including opening the unit for inspection.
2. Boilout:
- H. On completion of erection, inspect, and mechanically clean the unit. Inspect drums, headers, supply pipes, and tubes and remove all debris. Blow out and sound all parts which cannot be visually inspected.
 - I. Boilout the unit with chemicals furnished by Contractor. Provide heat source necessary to heat water to proper temperature. Provide all piping, hoses, and drain lines required to deliver water and chemicals to the unit for boilout and for disposal of wastes after boilout.
 - J. After boilout, open the unit, wash down, and inspect. Replace gaskets, gauge glasses, and other parts damaged by boilout with new material provided by this Contract.
4. Instrument Calibration:

- A. Provide instrument technician to field calibrate all instruments furnished by this Contract.
 - B. Provide instrument technician to check and tune all control loops furnished by this Contract, including checking valve action.
5. Setting Safety Valves:
- A. Set all safety valves under the direction of the safety valve manufacturer's service personnel. Provide service personnel from the safety valve manufacturer under this Contract.
 - B. Provide all labor and attendance as required for setting all safety valves.
 - C. Schedule and coordinate the setting of safety valves with other contractors' work and the overall Project schedule. The superheater safety valves cannot be set until the blowing of steam lines is completed.
 - D. Operated drain valves as required to remove condensate from the main steam lines while setting the superheater safety valves.
5. Chemical Cleaning:
- A. Provide the services of specialists in chemical cleaning of boilers to chemically clean the water sides of the unit. Chemical cleaning shall utilize citric acid followed by passivation.
 - B. Provide all labor, chemicals, compressed nitrogen gas, piping, valves, hoses, lances, pumps, and heaters required to supply and monitor cleaning solutions.
 - C. Provide all labor, pumps, piping, valves, and hoses required for disposal of wastes offsite. Contractor shall be responsible for locating disposal site off Owner's property and transporting wastes to a disposal site.
 - D. Provide all labor and attendance on a round-the-clock basis, if required, during the chemical cleaning operations.
 - E. Flush complete unit after chemical cleaning to include all tubes, headers, and downcomers. Provide all piping, hoses, and lances required for flushing. Contractor shall dispose of wastewater resulting from flush.
 - F. Remove, replace and seal weld hand holes, access openings, and pipe connections as required for chemical cleaning and flushing operations.
 - G. Wherever practical, parts subject to damage during acid cleaning shall

not be installed until acid cleaning is completed. Replace any parts damaged by acid cleaning.

6. Conduct complete testing of combustion control system and burner safeguard system, including the following tests:
 - A. Out-of-case bench testing of all protective relays in accordance with relay manufacturer's instructions for testing. This testing includes such tests as checking of relay timing, restraint, calibration, and contact operation.
 - B. In-case testing of all protective relaying systems before energization to assure that relays trip (and lockout, if required) the proper breakers or devices. These tests shall include operation of relay contacts electrically or manually and checking breaker or device operation, and shall include introducing currents and potentials at their source and observing relay operation.
 - C. Conduct all field tests in the presence of Owner.
 - D. Provide all labor and test equipment required for field testing.

PLACING EQUIPMENT IN OPERATION:

1. Prepare unit for initial operation by testing, flushing and making operational checks as required to prepare all equipment and systems for operation at times required to meet the Owner's schedule for the initial operation of the complete steam generator unit.
2. Provide the services of competent start-up service personnel during the start-up and initial operation of the unit to perform the following:
 - A. Direct the starting operation of all equipment furnished.
 - B. Direct the operation of the equipment until it is placed into successful operation and is ready for commercial operation.
 - C. Coordinate starting, stopping and loading of unit with Owner's existing steam, electric and natural gas utilities.
 - D. Instruct the Owner's personnel in the operation, care and maintenance of the equipment.
 - E. Consult with manufacturer's field service personnel and providing them assistance as required to conduct the necessary tests and make any

- required adjustments.
- F. Observe initial operation and direct Contractor's personnel to make adjustments as required for proper operation of the unit and its accessories and appurtenances.
 - G. Provide detailed written instructions for proper operation of unit, if such detailed instructions are not contained in the Instruction Books.
- 3. Procedures and work performed shall be as directed by the manufacturer's published procedures and service representative's instructions.
 - 4. Repack valves, clean strainers, make repairs, and make adjustments as required until complete unit and all auxiliaries and appurtenances are in continuous successful operation.

5.2.8.14 Ammonia Equipment

Contractor shall provide one (1) or more aqueous ammonia (19% solution) storage tank(s) with a minimum design pressure as required by Contractor's design. Total volume of the tank(s) shall be sized to contain two weeks worth of ammonia under 100% peak load conditions or 20,000 gallons, whichever is greater. Provide a containment dike for the area surrounding the tank consistent with ANSI K61.1 guidelines. Ammonia system shall be in accordance with ANSI K61.1 and OSHA standards.

Provide an ammonia unloading skid with break away truck connections and with automatic emergency shut-off valves on the liquid and vapor connections on tank. Provide all instrumentation required by ANSI K61.1 and as required to provide for a safe, unmanned operation. Provide one (1) level transmitter and two (2) pressure transmitters on tank for remote monitoring and control. Provide a local float type level gauge on tank.

Provide a platform and ladder to access all the manual valves and excess flow valves at the top of the tank and to maintain the relief valves and other instrumentation installed at the top of tank.

5.2.9 Steam Systems

The steam system shall be based on a three-pressure reheat cycle. The steam system shall be designed to provide HP, IP, and LP steam from the HRSGs to the steam turbine

generator as shown on the Conceptual Process Flow Diagram in Appendix D.

Pressure relief valves with silencers shall be provided on the HP, reheat, and low pressure steam headers to meet code requirements for overpressure protection. Upon steam turbine trip, the primary release of steam shall be to the condenser through the steam bypass system. The secondary release shall be through modulating start-up vent valves to the atmosphere. Locate the start-up vent valves close to the HRSG isolation valves and select the set points of these valves sufficiently below the steam drum relief valve setting to prevent lifting of the steam drum relief valves during overpressure transients.

The high pressure and reheat systems shall be provided with stop valves to allow isolation for safe maintenance and repair of either HRSG with the other HRSG in operation.

The steam systems shall be provided with a high-pressure drain system to remove condensate from stop and control valves and piping low points to prevent water induction into the steam turbine. Drains that require quick action during startup shall be supplied with air operated, severe service, metal-seated, ball valves. Drains not requiring quick action but are required for steam piping drains shall be supplied with inverted bucket type traps or air-operated valves. All high-pressure drains shall be discharged to the condenser or to the blowdown tank. All manual drains shall be piped to a drain header system that discharges to either the condenser or the blowdown tank if inadequate pressure exists to transport the condensate to the condenser. Steam piping shall be pitched in the direction of steam flow. All motor-operated valves, air operated valves, and steam traps shall be provided with a block valve on each side. Steam traps shall be provided with a valved bypass.

The design and construction for the drain system shall comply with the ANSI/ASME TDP-1, Recommended Practices for the Prevention of Water Damage to Steam Turbines.

The maximum pressure drop between the HRSG and the steam turbine generator interface shall be 5% of the upstream line pressure for the HP, 3% of the upstream line

pressure for the Hot and Cold Reheat lines, and 10% for the LP steam line. This maximum allowable pressure drop includes pressure drop across the piping, valves, and all other components in the piping.

All main steam piping shall meet the requirement of ANSI B31.1 and the ASME Boiler and Pressure Vessel Code.

5.2.9.1 HP (Main) Steam System

HP steam shall be piped from each HRSG HP superheater outlet to the steam turbine. Each HRSG supply header shall be provided with a non-return stop check valve and a motor operated stop valve. A dedicated HP steam turbine bypass system to the cold reheat system shall be provided on each HRSG HP header for operating flexibility. HP steam bypass system shall be provided with combination pressure reducing and desuperheating valve or separate pressure reducing valve and desuperheater. The bypass piping shall be high temperature alloy pipe up to the downstream desuperheating temperature measurement. The bypass system shall be sized for the maximum HRSG output without duct firing and shall be designed for continuous operation. Each HRSG HP superheated steam line shall also be provided with a low-pressure drop type flow element and transmitter for measuring steam flow. The HRSG supplier shall provide a start-up vent valve for each HP steam header to facilitate unit startup and relieve steam pressure buildup during peak load Steam Turbine trips.

5.2.9.2 Reheat Steam System

Cold reheat steam from the HP steam turbine exhaust shall be piped from the steam turbine to the individual HRSGs. The cold reheat line shall be provided with a power actuated stop check valve and motor operated stop valve. The cold reheat lines to each HRSG shall be provided with a modulating valve to proportion the cold reheat flows between the HRSGs and isolate the HRSGs from the common line. Contractor shall evaluate the steam turbine manufacture's entrain energy threshold to determine if relief valves are required for the cold reheat pipe between the steam turbine and the main isolation valve. Therefore, Contractor's shall include in the bid an allowance for these relief valves. IP steam from each HRSG shall be combined with the HRSG cold reheat steam return from the turbine and piped to each HRSG reheater section. The IP superheated steam line shall be provided with a non-return valve and motor operated

stop valve prior to connection to the cold reheat line for isolating the HRSG IP drum. Each HRSG IP superheated steam line shall also be provided with a low-pressure drop type flow element and transmitter for measuring steam flow. The HRSG supplier shall provide a start-up vent valve for each IP steam header to facilitate unit startup and relieve steam pressure buildup during peak load Steam Turbine trips.

The hot reheat steam shall be piped from each HRSG to a common header feeding the steam turbine. Each HRSG hot reheat line shall be provided with a dedicated steam turbine bypass system consisting of a combination pressure reducing, desuperheating valve or separate pressure reducing valve and desuperheater for operating flexibility. Each reheat bypass line shall be routed to the Parallel Condensing System ductwork and provided with a diffuser for installation in the PCS ductwork. The bypass system shall be sized for the maximum HRSG output without duct burning and shall be designed for continuous operation. Provide a motor-operated stop valve on the hot reheat line from each HRSG.

5.2.9.3 LP Steam System

LP steam from each HRSG shall be piped through a common header to the steam turbine and admitted to the LP steam turbine section. Each HRSG LP steam line shall be provided with a non-return valve and motor-operated stop valve prior to connection to the common header. The LP steam system shall be designed to bypass the entire steam flow to the air-cooled condenser during startup, shutdown, steam turbine trip, sudden load changes, and when the steam turbine is out of service. The bypass system shall be sized for the maximum HRSG output without duct firing and shall be designed for continuous operation. Each LP steam bypass line shall be routed to the Parallel Condensing System ductwork and provided with a diffuser for installation in the PCS ductwork. Each HRSG LP superheated steam line shall also be provided with a low-pressure drop type flow element and transmitter for measuring steam flow. The HRSG supplier shall provide a start-up vent valve for each LP steam header to facilitate unit startup and relieve steam pressure buildup during peak load Steam Turbine trips.

5.2.9.4 Auxiliary Steam System

All required auxiliary steam systems shall be furnished and installed to result in a

complete, fully operational plant. The primary source of auxiliary steam shall be the Block 1 Auxiliary Boiler. Block 1 and Block 2 auxiliary steam systems shall be cross-tied together to provide steam to either unit. Auxiliary steam shall be used for start-up steam seal supply to the steam turbine, Intermediate Pressure steam to the Cold Reheat Steam System, steam jet air ejectors, and for deaerator pegging steam. The auxiliary boiler shall be backed up with desuperheated main steam from either operating unit and supplemented with cold reheat steam for the steam jet air ejectors.

5.2.10 Condensate System

The condensate systems shall be provided as shown in the Conceptual Process Flow Diagram contained in Appendix D. Condensate shall be collected in the Condensate Receiver Tank. The condensate system shall pump condensate from the Condensate Receiver Tank through the gland steam condenser to the LP steam drum and other related plant systems. Makeup to the Condensate Receiver Tank shall be provided from the demineralized water storage tank.

Major equipment quantity and capacities shall be as follows:

Equipment	Quantity	Design Capacity
Condensate Pumps	2	100% Peak Load system demand

The Condensate Pumps shall take suction from the Condensate Receiver at the Air Cooled Condenser and supply condensate to the LP economizer and LP drum. A control valve shall be provided to regulate the condensate flow based on LP drum level using a three-element control system. Provide a vortex breaker and dam on the condensate pump suction connection to prevent sediment from entering the pump suction lines. Provide a factory calibrated ASME flow nozzle meter on the Condensate Pump feed to each HRSG. All steam flows shall be corrected to match the flow from this meter.

Provide condensate pumps with stainless steel wetted parts and include duplex type suction strainers at the inlet of each pump. Condensate pumps shall be multistage, vertical, open line-shaft canned pumps with suction nozzles in the discharge head. Design pumps to operate continuously and include a minimum of 3 feet NPSH margin on pump assuming zero (0) NPSH at the suction nozzle.

A condensate system minimum flow recirculation line shall be provided and shall connect downstream of the gland steam condenser and discharge into the condensate receiver above the maximum water level. This line shall be designed to provide a minimum flow re-circulation protection for the Condensate Pump and the gland steam condenser. Each Condensate Pump discharge and suction connection shall be vented by individual lines back to the condensate receiver. During normal operation, makeup to the condensate receiver shall be supplied by vacuum drag from the demineralized water storage tank. The demineralized water pumps shall also be designed to supply the condensate receiver when condenser vacuum is not available. Provide taps off of the discharge of the condensate pumps to allow for future installation of full stream filter for iron removal.

All piping and components from the demineralized water system shall be made from corrosion-resistant stainless steel capable of handling this type of water.

5.2.11 Boiler Feedwater System

The boiler feedwater system shall be provided as shown in the Conceptual Process Flow Diagram in Appendix D. The system shall be designed to deliver feedwater from the LP drum to the corresponding HRSG HP and IP drums through their respective economizers over the full range of plant operation. The feedwater pumps shall also supply spray water to plant desuperheaters and attemperators.

Two identical boiler feedwater pumps shall be provided for each HRSG. Each pump shall be designed to provide 100% of the HRSG feedwater demand and other system demands at Peak Load operation with 100% duct firing of the HRSG. For maximum Peak Load operation, both feedwater pumps shall operate to provide the total system demand for one HRSG. The HRSG feedwater pumps shall be segmented ring pumps with a main discharge providing HP feedwater and an inter-stage bleed port providing IP

feedwater to the system. Using pressure letdown valves to reduce the pressure of the HP feedwater for IP service is not acceptable. The feedwater pumps shall be provided with all required auxiliary systems including warm-up system; vibration monitoring and alarms; seal water system; forced lubrication system; and NPSH protection. Provide suction strainers on each boiler feedwater pump suction inlet. Design feedwater pumps with a minimum ratio of NPSHA / NPSHR of 2 to 1 at the worst case operating or transient conditions.

Boiler Feedwater Pumps shall be equipped with Bentley Nevada vibration monitoring system - X-Y Prox Probes (2 per pump bearing) and the Key Phasor Probe (1 per pump). The boiler feed pump vibration monitoring system shall be tied in to the existing main Bentley Nevada System 1.

The feedwater pumps shall be electric motor driven. A flow element, check valve, and isolation valve shall be provided in the HP and IP discharge piping of each pump. A three-element feedwater control system shall be provided to regulate the flow of feedwater to maintain IP and HP drum level. Each pump shall have a minimum flow recirculation system that discharges into the LP drum. The recirculation system shall include a modulating control valve, with a pressure break down orifice located at the LP drum, controlled from a flow element measuring flow through each pump. During low load, the control valve shall maintain minimum flow required for safe pump operation.

Boiler feedwater pumps shall be provided with mechanical seals. Basket type strainers shall be installed in the suction lines to protect the pumps from damage.

A pump warm-up line shall be provided downstream of each pump discharge isolation valve to maintain an idle pump in a ready condition while the other pump is in operation. The line shall be designed to recirculate warm water from the discharge header through the idle pump casing back to the suction piping. A restriction orifice shall be provided in each warm-up line to maintain the warm up flow and reduce the pressure.

5.2.12 Raw Water Supply System

The raw water supply system shall be provided to receive raw makeup water from the off-site wells for use as firewater, service water, makeup to the evaporative coolers and

makeup to the Demineralizer System. Raw water analysis is provided in Appendix I. The existing combined fire water/raw water tank shall be converted for use only for raw water. Two new 300,000 gallon fire water tanks shall be provided.

5.2.13 Service Water System

The service water system shall be provided to receive service water from the raw water tank and distribute the water to the demineralized water system, water treatment system, service water users and stations.

Provide service water stations within 100 feet of all areas needing service water for routine maintenance or cleaning. Provide a minimum of two service stations at the boiler water treatment skids. Provide service water to all equipment requiring service water for seal flushes or other purposes.

Provide a 100-foot service water hose and hose bib at all service water stations.

5.2.14 Raw Water Treatment System

The Raw Water Treatment System shall be designed to receive and treat water from the on-site wells. Raw water treatment shall consist of filtration by multimedia filters.

A complete filtration system shall be provided including but not limited to backwash pumps and air scour blowers. The Raw Water Treatment System shall treat the well water supply for use as makeup to the evaporative coolers and makeup to the Demineralized Water System. A coagulant feed system shall be provided to feed coagulant to the influent of the multimedia feed system.

Equipment	Total Quantity	Design Capacity
Multimedia Filters	3	50% of System Capacity (with one spare 50% multimedia filter)
Coagulant Feed Skid	1	1 coagulant Feed System with 2-100% pumps
Backwash Pump	2	100% of Design Capacity

Air Scour Blowers	2	100% of Design Capacity
-------------------	---	-------------------------

5.2.15 Demineralized Water System

The Demineralized Water System shall consist of inlet cartridge filters, a 2-pass reverse osmosis system, a first pass permeate break tank with a minimum retention time of 20 minutes, a electrodeionization system (EDI), demineralized water storage tank and all necessary pumps, piping, valves, etc. for a complete system. The system shall also include provisions for addition of a rented, offsite regenerated, mixed bed ion exchangers, including connections, instrumentation, and bypass valves. System capacity shall be such that all plant requirements are satisfied at peak water requirements providing no less than 5% of makeup main steam flow.

The Demineralized Water System shall be designed to produce high quality demineralized water that will not exceed the following maximum guarantee limits in the effluent of the demineralization system:

Cation Conductivity:	0.1 $\mu\text{mho/cm}$
Silica:	10 $\mu\text{g/l}$
Sodium:	10 $\mu\text{g/l}$

Major equipment capacities shall be as follows:

Equipment	Total Quantity	Design Capacity
Feed Pumps from Storage	2	100% of System Capacity
Cartridge Filters	2	100% of System Capacity
1 st Pass RO Feed Pumps	3	50% of System Capacity (Including one common spare pump)
1 st Pass RO Units	2	50% of System Capacity
2 nd Pass RO Feed Pumps	3	50% of System Capacity (Including one common spare pump)
2 nd Pass RO Units	2	50% of System Capacity

RO Chemical Cleaning Skid	1	100% Capacity of One Unit
RO Chemical Feed Pumps	2	Per chemical feed
RO Permeate Break Tank	1	20-minute RO permeate retention storage
EDI	2	50% of system capacity
Demineralized Water Storage Tank	1	200,000 gallons
Demineralized Water Pumps	2	As required to supply demineralized water users

Provide horizontal, centrifugal, RO feed pumps. Each pump shall be sized to provide the full capacity flow rate of the RO units.

Provide two pre-assembled, skid mounted, cartridge filter(s) at the inlet to the RO system. Provide filter housing constructed of type 304 stainless steel, minimum. Each filter shall consist of replaceable 2-inch diameter, 10-micron absolute, filter cartridge elements. Provide differential pressure transmitters across each filter to alarm control system upon detection of high differential pressure. Each filter shall be sized for 100% of the RO inlet flow rate.

Provide horizontal, centrifugal, RO feed pump(s) constructed of stainless steel wetted parts. Provide 2-pass RO units with all piping factory assembled, permeate discharge, and reject header for each unit.

Design each RO unit for in-place cleaning and provide necessary facilities to facilitate the cleaning, including but not limited to, a chemical solution tank, heater, cartridge filter, and horizontal centrifugal cleaning pump. Provide a post shutdown brine flush on each unit that bypasses the reject control valve while flushing is taking place and uses RO product water as the flushing source. Construct RO element housings of FRP. Use stainless steel piping for all interconnecting piping and headers. Provide sample connections on the inlet and each housing outlet to facilitate the collection of grab samples. Provide RO membranes with a minimum guaranteed life of three years in the intended service and with a minimum salt rejection of 99.5% at the beginning of

membrane life with an annual salt passage increase of no more than 10% through membrane life. Provide pressure and flow transmitters on the inlet and permeate header on the reject connection of each RO system, and as required to allow automatic trending of membrane performance per ASTM D-4516, Standard Practice for Standardizing Reverse Osmosis Performance Data. Provide pH and conductivity meters on the RO inlet and permeate headers.

The system shall be furnished with a turbidity meter that measures the product water from the R.O. system. The system shall have automatic shut down capability in the event the product water is out of specification.

A stainless steel RO permeate break tank shall be provided with capacity to hold at least 20 minutes of storage of 1st Pass RO permeate.

Provide two, 50% capacity, permanent, on-site, EDI units to polish the effluent from the two-pass RO system. The EDI polishers shall be sized as required to fulfill permeate requirements. Provide a pressure transmitter on the outlet of each EDI unit. Provide a flow meter on the inlet and outlet of each EDI unit. Provide a conductivity probe on the outlet of each EDI unit. Provide connections downstream of the common EDI unit outlet for connection of offsite regenerated mixed bed ion exchange vessels. Include manual isolation valves and bypass valves. Provide a conductivity probe downstream in the common outlet of the rental mixed bed ion exchangers.

The R.O. system shall be designed to prevent back-pressurization of the R.O. system that could lead to membrane damage or failure.

The new and existing Demineralized Water Storage Tanks shall be crosstied to be common to both Block 1 and Block 2 and valved to allow either to be taken out of service for maintenance.. The new Block 2 demineralizer system shall be installed adjacent to the existing Block 1 Demineralized Water Storage Tank and demineralizer system, or at a location approved by Owner.

Provide horizontal, centrifugal, demineralized water make-up pumps constructed of stainless steel wetted parts. Provide a pH probe, conductivity probe, silica analyzer, and

a temperature probe on the pump outlet header. Provide a flow meter on the demineralized make-up water line to each condenser.

The RO system shall be furnished with all necessary chemical injection systems including but not limited to a RO inlet de-chlorination (if upstream water is chlorinated), RO polymer feed and RO inlet acid feed. All chemicals will be fed directly from tote containers provided by the chemical supplier using redundant chemical injection pumps.

A caustic feed skid shall be provided for injecting caustic between the 1st and 2nd Pass RO for removal of carbon dioxide (if required). The caustic feed rate shall be automatically controlled to achieve an operator selected pH level at the inlet to the 2nd pass RO banks. The caustic feed skid shall consist of two (2) 100% capacity feed pumps which will feed directly from portable tote containers.

The demineralized water system shall be located inside the Water Treatment Building. Chemical storage totes shall be located indoors.

5.2.16 HRSG Blowdown Recycle.

All-volatile treatment of the steam cycles is envisioned for the station. As such the blowdown is expected to be suitable for reuse. A reuse system shall be provided to allow reuse of HRSG blowdown. The collected blowdown shall be cooled and routed to the demineralizer system for treatment prior to reuse as cycle makeup. The contractor shall supply all necessary coolers and recycle tanks, valves, and pumps necessary to accomplish reuse of the boiler blowdown. As a minimum, the contractor shall supply a flash tank for recovery of steam from the blowdown, coolers to reduce blowdown temperature to acceptable levels for reuse in the demineralized water systems filters for removal of particulates, and a recycle tank for collection of the cooled and filtered blowdown. The system shall be automated to the greatest extent practical. Recovery of the heat in the blowdown shall be to the steam cycle to the greatest extent practical

5.2.17 Air Cooled Condensing System

Contractor shall provide an Air Cooled Condenser (ACC) System for turbine exhaust and by-pass, complete with all auxiliaries and accessories including the following:

1. Galvanized steel or aluminum fin tube bundles (with integral condensate collection/crossover headers and jacking bolts) or single row tubes
2. Lifting beam for tube bundles
3. Galvanized steel A-Frame support structure for fin tube bundles, including partition walls and doors
4. Galvanized steel fan deck
5. Galvanized steel ACC support structure, including perimeter walkway, handrails, and one (1) escape ladder
6. One (1) galvanized stairway from grade level to fan deck
7. Galvanized steel fan support bridges, including handrails
8. Fan rings with inlet bells
9. Galvanized steel fan guard grills
10. Axial-flow, aluminum fans
11. Gearboxes, including couplings, backstops, oil level pressure switch, and a AGMA service factor of 2.0 or greater
12. Variable speed TEFC electric motors, including space heaters and a 1.15 service factor
13. Transfer beam monorail and hoist for motor removal
14. Steam distribution header for each ACC row (with integral blanking plates for testing purposes)
15. Mechanical vibration switches (one per air moving assembly), temperature sensors, and pressure transmitters
16. Rupture disk assembly, including a platform and one (1) moveable ladder
17. Condensate collection piping and drain piping
18. Air removal headers and piping

19. Windwall (above fan deck level) and associated galvanized steel support structure
20. Steam duct from the turbine to the ACC, including expansion joints, inspection manhole, supports, and bypass connections
21. Steam duct drain pot and drain pot pumps, including level transmitters
22. Skid-mounted liquid ring vacuum pump system including integral piping, integral instrumentation, and automatic inlet valve
23. Vacuum deaeration system
24. Interconnecting bolting hardware and gaskets
25. Complete system control logic narrative
26. Training (5 days, one trip)
27. Freight (all material and equipment, FOB project site)
28. Thermal, hydraulic, mechanical, and structural design of equipment
29. Wind mitigation design and material supply.
30. Three jigs for modular construction of the cells at grade level

Liquid Ring Vacuum Pumps

1. 2 x 50% Hogging pumps, with all accessories as required, to hog condenser to 6" Hg in 30 minutes

Steam jet air ejector holding systems

Freeze protection features

Instrumentation sensors, transmitters, and control actuating devices

Complete system logic specification in narrative form for incorporation into plant DCS.

Noise attenuation features/devices, as required.

All bolting and gaskets.

Surface coatings, as follows:

1. Structural steel and fan deck platework to be galvanized.
2. Stair treads, support steel, grating, handrails and walkway surfaces to be

galvanized.

3. Steam ducting, steam headers and piping to be outside primer coated.
4. Partition walls, windwalls and siding shall be finish painted with manufacturers standard coatings.

Special maintenance and erection tools

Submittals: Contractor shall provide ACC certified performance correction curves for all applicable design parameters including, but not limited to:

1. Steam flows of 50, 90, 100 and 110 percent of guaranteed steam flows for Parallel Condensing System.
2. Steam flows of 50, 90, 100 and 110 percent of guaranteed steam flows for Air Cooled Condenser.
3. Ambient Temperature.
4. Wind velocity.

Factory Tests:

1. Include all manufacturer's standard factory tests on Equipment and Material.
2. Notify Engineer at least two weeks in advance of tests so that a Engineer representative can be present if desired.
3. Submit copies of reports on all factory tests conducted.
4. The ACC Condensate Tank shall be hydrostatically tested by manufacturer at 1.5 times the working pressure per ASME Section VIII.

Pressure Tests: The ACC and steam distribution ducts will be subjected to pneumatic pressure test after erection is complete.

5.2.17.1 Design Parameters

The Air Cooled Condenser shall maintain the guaranteed maximum backpressure at Steam Turbine exhaust flange under the following conditions (Performance will be corrected to ambient temperature, condensing capacity, and wind speed in accordance with guaranteed correction curves):

- | | |
|--------------------------------------|----|
| 1. Ambient dry bulb temperature (°F) | 95 |
| 2. Relative Humidity (%) | 18 |
| 3. Wind Speed (mph) | 10 |

4. All Ambient Wind Directions

Turbine Bypass Guarantee Conditions: The Air Cooled Condenser shall be capable of maintaining the maximum guaranteed backpressure at the Steam Turbine exhaust flange while condensing full Hot Reheat Turbine Bypass and Low Pressure Steam Turbine Bypass steam flows (Performance will be corrected to ambient temperature, condensing capacity, and wind speed in accordance with guaranteed correction curves contained):

- | | |
|--|--------|
| 1. Ambient Dry Bulb Temperature Range (°F) | 15-120 |
| 2. Relative Humidity (%) | 16 |
| 3. Wind Speed (mph) | 10 |
| 4. Any ambient wind direction. | |

Liquid Ring Vacuum Pump Guarantee: The vacuum pumps operating in parallel shall be capable of hogging PCS down from atmospheric pressure to 6" Hg Abs. in no more than 30 minutes.

Maximum O₂ and non-condensable gases in the condensate sampled at the Condensate Pump discharge shall be less than seven (7) ppb at all operating conditions.

Equipment noise shall not exceed requirements specified in Section 1 .

ACC performance shall remain in accordance with Guaranteed Correction Curves at all operating and ambient conditions. STG exhaust steam shall be condensed in the ACC at all ambient conditions.

5.2.17.2 Air Cooled Condenser (ACC)

The air cooled condenser will be supported from grade. The condenser, accessories and components shall be supported on braced structural steel columns designed and fabricated in accordance with codes, standards, seismic and wind load conditions as required and specified. The condenser and its components shall be of proven, dependable design, of high quality new materials with first class workmanship throughout, and arranged to minimize maintenance work.

Platforms, stairs, and ladders shall be furnished to provide access to the condenser Sections, valves, controls, motors, fans and accessories. Access platforms, stairs and

ladders shall be steel.

The Air Cooled Condenser shall be arranged as follows:

1. The condenser shall be designed for full vacuum and a positive pressure of standard atmospheric pressure for elevation at the jobsite.
2. Contractor shall determine the steam inlet size which results in the most economical overall condenser and auxiliaries design.
3. Adequate provision shall be made for thermal movement under the range of temperatures and pressures that will be encountered in operation. No leakage of steam or water shall be allowed. Air in-leakage shall be below industry codes and standards and within the limits to maintain the guaranteed performance. No bypassing of air around the heat transfer surfaces shall be allowed. Expansion joints with gaskets and fasteners, guides, braces, and stiffeners, etc. shall be provided as required.
4. The condenser shall be designed to allow freeze proof operation at specified minimum steam flow and concurrent minimum ambient temperature. The tubes, headers, drain pots, and piping shall be sized and designed to drain freely and completely to prevent damage due to freezing. Freeze protection features shall be described in detail in the proposal.
5. The condenser shall be designed to accommodate plant load swings from maximum to minimum (1 GTG at OEM minimum load) as specified herein throughout range of ambient temperatures at the plant site. The condenser shall be capable of operating with modules shut down to maintain optimum turbine exhaust pressure.
6. The condenser shall be capable of maintaining optimum turbine exhaust pressure and plant efficiency by incorporation of various design features such as sectionalizing, etc.
7. The condenser shall be of the A-frame type with A-frames elevated sufficiently for proper air inlet distribution. Jacking bolts shall be provided on all A-frames to permit proper alignment of bundle tube sheets for purposes of

seal welding.

8. The condenser and related components shall be of proven design, utilizing new materials and arranged to facilitate maintenance. Provisions shall be made in the design and construction of the condenser, condenser components, exhaust duct, piping, headers, supports and accessories for thermal movement under the range of temperatures and pressure encountered in operation. Expansion joints at the turbine exhaust, in the ducts and piping, and at the condenser shall be designed for the service.
9. All portions of the condensing system that are associated with containing steam and condensate shall be of seal welded construction. This includes ducting, piping, tube sheet and tube-to-tube sheet connections. Gasketed joints and threaded connections are not acceptable.
10. Welding procedures, processes, equipment and craftsman shall be qualified in accordance with applicable Sections of the ASME or AWS Codes.
11. Contractor shall maintain a high level of quality control to minimize debris and other contamination entering the system during erection of the ACC in order to facilitate cleaning of the system during start-up.
12. Reverse buckling rupture disc type pressure relief device for each isolatable condenser section shall be provided.

Components:

Fans:

1. Fan blades shall be secured to a common hub and shall be constructed of fiberglass reinforced polyester (FRP) or extruded aluminum, and have adjustable pitch.
2. Blades shall be axial flow aerodynamically designed type.
3. Fan blades shall be weight and moment balanced and shall be interchangeable. Fan hubs and blades shall be statically balanced prior to shipment to the jobsite.

4. A fan guard shall be provided below each fan. The fan guard shall be designed so that it can be used as a maintenance platform using plywood or wooden planks.
5. Provide a fan ring of molded fiberglass duct to house the fan and provide accurate adjustment of the blade tip clearance for optimum efficiency.
6. The fan shall be provided with means to stop backward rotation prior to fan startup.
7. Fans shall be supplied with motors in accordance with SECTION 8.
8. Fan motors shall not exceed 250 horsepower.
9. Two single pole double throw vibration switches of the manual reset type, shall be provided for each fan drive for input into the plant (DCS) alarm system and for motor shut down. One switch shall be set at high level and the second switch shall be set at high-high level to shutdown each respective fan.
10. Each fan shall be driven through a speed reduction gearbox suitable for continuous service in a dry air cooled condenser environment.
11. The gearbox shall be designed in accordance with AGMA standards.
12. The minimum mechanical design service factor shall be 2.0 referred to motor nameplate rating.
13. A sight gage shall be incorporated to indicate oil level.
14. Bearings shall have an L-10 life of 50,000 hours or greater.
15. An oil pressure or flow switch shall be provided for each gear box.
16. Fans shall not stall under any operating or ambient conditions.
17. Maximum vibration level at fan deck shall not exceed 0.1 inch/sec.

Windwalls:

1. Windwalls shall be provided for installation around the perimeter of the A-

frame Section of the air cooled condenser, minimally extending from fan deck level to the top of heat exchanger bundles, to minimize air recirculation, tube freeze-up, or excessive noise.

2. If louvers and/or operable dampers are required, these shall be furnished sized and designed to withstand wind, seismic and operating loads as specified herein. Damper blades shall be horizontal, with maximum length of 6 ft. Damper actuating motors shall be supplied for each Section, sized for wind and fan loads as required by design and this specification. Louvers shall be heavy duty industrial type, suitable for outdoor operation.
3. Wind mitigation shall be provided at the perimeter of the cells, below the fan deck level, as required, to minimize fan inlet air starvation due to high ambient wind conditions.

Controls:

1. The air cooled condenser system shall be designed for automatic operation at all loads and ambient conditions.
2. The air cooled condenser controls shall be implemented through the plant's distributed control system (DCS).
3. ACC Control System shall be designed to prevent freezing of equipment.

Fin Tubes:

1. Shop installed into tube sheets by the condenser manufacturer. The manufacturer should make the method of tubing clear in the proposal.
2. Furnish and deliver the specified number of tubes suitable for the application and in conformance with the design parameters and specifications.
3. Tubes shall be constructed of hot dipped galvanized carbon steel tubes.
4. Fins shall be constructed of carbon steel with all exterior fin tube surface hot dipped galvanized or aluminum.
5. Fin tubes shall be designed such that the interspace between the fin flange

and the tube is filled with zinc during the galvanizing process.

6. Fin tube bundles shall be designed to allow free thermal expansion of the tubes. Single row tubes may be supplied by Contractor.
7. Tubes shall be easily cleaned using automatic cleaning equipment provided by Contractor. System shall be furnished complete to include, but not limited to, pumps, nozzles, piping, valves, controls and instruments. System shall utilize raw make-up water for washing tubes.
8. Fin tube bundles shall be arranged to facilitate cleaning and minimize air side pressure drop.
9. Fins shall be capable of withstanding, without damage or deformation, frequent applications of high pressure water jet sprays directed on fins for cleaning purposes.
10. The fins shall also be capable of withstanding hail up to 1.25 in. in diameter, and localized loads applied by personnel stepping on the fins during erection or maintenance.
11. Fin pitch shall not exceed 11 fins per inch.
12. Air evacuation system shall be designed to continuously remove non-condensibles and maintain performance at all ambient conditions.

5.2.17.3 Steam Duct:

Contractor shall furnish a carbon steel steam duct from the turbine exhaust connection to the air cooled condenser inlets, including duct transition piece at turbine interface, expansion joints and structural supports and/or hangers, as required.

Steam duct connections shall be butt or socket welded except where bolted or flanged connections are required for maintenance and equipment connection. Flanges shall be, as minimum, steel ring flanges in accordance with AWWA Class D (150 psi). Where flanges are employed, associated fasteners and gasketing shall be provided. Access manhole(s) in the steam duct to allow for internal inspection and maintenance of the steam duct system between turbine and condenser shall be provided. Manholes shall

be 24" steel pipe nozzles including an ANSI 150 lb. flange plus blind flange. Duct sections shall be shipped in the maximum size allowable from shipping regulations. Ends shall be machine beveled suitable for field welding except where field trimming is required.

Contractor shall add a flanged connection to the main duct to allow for the future addition of a heat exchanger using supplemental cooling from an evaporative type cooling tower. Connection shall be sized to allow for supplemental cooling up to 30% of the total heat load.

Low point drain pot(s) sized to collect condensation during start-up and normal operation shall be provided. Condensate shall be automatically returned to the condensate tank using two (2) 100% drain pumps.

The steam duct shall be designed for full vacuum and for a pressure up to 14.9 psi.

Expansion joints shall be incorporated in the steam ducting to accommodate thermal movements and to minimize loads on connection points. The expansion joints shall be metal bellows type stainless steel welded construction with tie bolts, lifting lugs and accessories, designed in accordance with Standards of the Expansion Joint Manufacturers Association, Section C. The expansion joint located at the turbine connection point may be an elastomeric type. Expansion joints shall be sized and designed to accommodate at least two (2) times the calculated lateral, axial and offset movements.

A spray curtain shall be provided in the vertical section of the main steam duct to protect the Steam Turbine from by-pass steam high temperature. Inlet water piping and control shall be supplied by others.

5.2.17.4 Condensate Receiver Tank

Contractor shall provide a Condensate Receiver Tank sized to provide a minimum of 5 minutes of storage capacity based on 0°F fired case design condensate flow. Normal water level of the tank shall not be higher than 50% of the total volume of the tank. Provide adequate volume in the condensate receiver tank above normal operating level to allow all condensate in the condenser to flow into the condensate receiver tank without overflowing. Condensate Receiver Tank shall be insulated and heat traced.

Condensate Receiver Tank shall be designed for standard atmospheric pressure for elevation at the jobsite to full vacuum with immersion heaters, and designed in accordance with Section VIII, Division 1 of the ASME Boiler and Pressure Vessel Code.

Condensate Receiver Tank shall be designed to include a sparger for water make up to reduce the oxygen content to 14 ppb or less at steady state operation. Maximum water make up shall be no more than 3% of the condensate flow.

5.2.17.5 Piping and Valves:

As a minimum, the following ducting and piping shall be furnished:

1. Steam distribution ducting from the main steam duct to individual air condenser sections.
2. Condensate collection and drain piping
3. Air removal piping
4. A pressure equalizing pipe between the main steam duct and the condensate receiver shall be provided.

To minimize the amount of field welding, shop assembled components shall be of the largest size possible commensurate with transportation and handling limitations.

Motorized condenser sectionalizing valve(s) shall be provided as required with related components, two (2) motorized fast acting (6 minutes to atmospheric) condenser vacuum breaker valves. Valves shall be sized for full line size and furnished with motor-operated actuators, including position indication. The valve body and disc shall be carbon steel and designed for tight shutoff.

5.2.17.6 Cold Weather Operation

Condenser shall be designed to allow safe operation at the specified minimum continuous steam flow and winter ambient design temperature and shall be able to operate with 10% steam flow during start-up period. Tubes, headers, drain pots, and piping shall be sized and designed to drain freely to prevent damage due to freezing.

Motor operated louvers and/or operating sectionalizing valves shall be furnished for cold

weather operation as required.

5.2.17.7 Steam By-pass System:

The air cooled condenser shall be designed and constructed to receive full bypass steam flow from the heat recovery steam generators (HRSGs) during startup and trip conditions.

The bypass system shall be designed for the maximum HRSG steam output without duct burning and shall be designed for continuous operation.

5.2.17.8 Air Removal Equipment:

Contractor shall provide 2 x 50% capacity vacuum pumps for hogging and a steam jet air ejector (SJAE) holding system for condenser air removal. Design capacity shall be sufficient to reduce pressure to 6 inches of Hg in the entire Air Cooled Condensing system in less than 30 minutes. Provide a 1 x 200% Inter/After condenser. All venting and discharge lines shall be routed to a safe area.

Each vacuum pump unit shall include the following:

1. Two-stage rotary vacuum pump with cast-iron construction, steel shaft, liquid ring, and electric motor drive.
2. Structural steel base to accommodate pump, motor, and accessories.
3. Flexible coupling, gear-type or Falk Steelflex.
4. Coupling guard complying with all state and federal safety requirements.
5. Steel plate separator with gauge glass, automatic makeup valve, and overflow connection.
6. Automatic inlet valve for main vacuum line from condenser.
7. System vacuum switch to start standby unit.
8. Balanced check valve for separator discharge with soft seat and lever arm for air leakage test.
9. Solenoid valves for valve actuators.
10. All required vacuum and differential pressure and temperature switches.

11. Rotameter for air leakage measurement.
12. A manually operated siltation valve shall be provided at the inlet of each vacuum pump for maintenance.
13. Automated valve, strainer, rotameter, and pressure gauge for water service.
14. Heat exchanger with stainless steel double-grooved, rolled tubes sized for 100°F cooling water.
15. PRV for instrument air control.
16. Complete set of integral interconnecting piping, fittings, tubing, and valves.
17. Complete interconnecting wiring with terminal box and terminal blocks for Owner's connecting wiring.
18. Painting: Shop coat all carbon steel surfaces with manufacturer's standard metal coating suitable for the outdoor service intended.

5.2.18 Chemical Injection Systems

Chemical feed equipment shall be provided to supply water-conditioning chemicals to the boiler steam/water cycle systems and plant wastewater systems. Each system shall be skid-mounted and shall include chemical pumps, piping, instrumentation and controls. All chemical tanks and totes shall be provided with containment to prevent contamination due to chemical leakage. All containment areas shall be sloped to drain to a sump providing convenient suction for the use of portable sump pump or vacuum truck hose. All chemical feed systems shall be monitored, controlled and injection rate adjusted from the plant DCS. Wherever possible, chemical feed pumps shall be identical. All chemical feed systems shall be designed for 100% redundancy at Peak Load. All chemical feed systems shall be located indoors.

5.2.18.1 Boiler Water Chemical Systems

Although all-volatile-treatment is envisioned, provisions for adding boiler additive chemicals to the HP and IP drums individually shall be provided. The boiler steam/water cycle chemical injection systems shall provide chemical treatment and include the ability to inject boiler additive chemicals to the IP and HP drums individually, and aqueous ammonia to the condenser pump discharge. Chemical feed equipment and tanks shall be located inside a heated and ventilated building and shall be arranged to allow clear

access to the chemical tanks with a fork truck or other suitable maintenance equipment. Chemical feed system shall be segregated from all other systems in the building with a barrier wall. Provide adequate ventilation to prevent the accumulation of chemical fumes per Industrial Ventilation Standards. Provide facilities suitable for stacked 500-gallon aqueous ammonia supply totes and for a minimum of two carboys of dry boiler additive chemicals storage in the chemical treatment building.

Provide a dedicated chemical feed system and chemical feed system enclosure for each HRSG. The descriptions included in the following paragraphs are typical of the chemical feed systems.

A boiler additive system shall be provided for each HRSG. Each boiler additive system shall consist of a solution tank with mixer and three 100% metering pumps. One dedicated pump will supply boiler additive to the HP drum and a second pump to the IP drum. The third pump will serve as a spare.

The aqueous ammonia feed system shall be provided to maintain a selected pH level and shall have two 100% metering pumps with automatic stroke positioners and variable speed drives. The ammonia feed system shall have the capability of being fed either from a dilution/day tank or a portable tote. The dilution/day tank shall be directly piped to the facility bulk storage 19% aqueous ammonia tank. The system shall be equipped with two 100% transfer pumps that will allow the transfer of aqueous ammonia from the bulk storage tank to the dilution/day tank. One pump shall feed aqueous ammonia directly from a portable tote to the steam cycle with the second pump acting as a spare. A day tank shall also be provided with a demineralized water connection for dilution of aqueous ammonia provided by tote (if operationally desired). The chemical supplier will supply the portable totes. Control of the aqueous ammonia feed will be in proportion to the condensate pH with a feedback control from condensate specific conductivity. The tote and dilution day tank shall be vented outdoors.

5.2.19 Powdered Resin Condensate Polisher

Provide a powdered resin condensate polisher system to filter and demineralized

condensate returning from the air cooled condenser.

Scope of Supply

Scope of supply shall include furnishing the powdered resin condensate polishing equipment indicated on the Powdered Resin Condensate Polishing Equipment Specification Sheet included at the end of this section.

Performance and Design Requirements

Performance and design requirements are covered in the Powdered Resin Condensate Polishing Equipment Specification Sheet included at the end of this section.

Materials

The following materials shall be used:

Component	Material
Filter polisher vessel	ASME SA516, Grade 70
Filter elements	Type 304 or Type 316 stainless steel or polypropylene filament wound on a stainless steel core
Element support sheet	Type 304 or Type 316 stainless steel
Strainer housings	Carbon steel
Strainer basket and screen assemblies	Type 304 stainless steel
Precoat tank	ASTM A36/A36M-87 carbon steel
Precoat tank internal, wetted, noncoated surfaces	Type 304 or Type 316 stainless steel
Mixer shaft and propeller	Type 304 or Type 316 stainless steel
Air, vent, and dome drain valves	Type 316 stainless steel
Miscellaneous plug valves	Carbon steel

Test Requirements

The following testing shall be conducted in accordance with the specified source.

Tests	In Accordance With	Conducted By
System performance test	Technical Specifications	Purchaser
Total dissolved solids concentration	AWWA 1030, Method F and AWWA 2540, Method B	Purchaser
Silica concentration	AWWA 4500 - Si, Method E for low level silica using Nessler tubes as the measuring device	Purchaser
System performance tests	Technical Specifications	Purchaser

Products

The design of the powdered resin condensate polishing system shall include the filter polishers, precoating facilities, effluent strainers, interconnecting piping, instrumentation and controls

Design Criteria

The powdered resin condensate polishing system shall be designed for removal of suspended and soluble contaminants from the condensate. The system design and its performance guarantee shall be based on the influent conditions, effluent requirements, and other pertinent design data specified on the Specification Sheet included at the end of this section.

The system shall be designed to allow application of powdered ion exchange resin, filter precoat material, or a combination of the two to the filter elements. A tank with mechanical agitator shall be provided for preparing the precoat slurry. A precoat pump shall be provided to transfer the slurry from the mixing tank to the filter elements and to recirculate the slurry through the filter polisher until the precoat operation is complete.

The design influent condensate analysis for normal, leak conditions, and transient conditions given on the Specification Sheet at the end off this section shall be used as the design basis.

Guarantees and Performance Tests

The powdered resin condensate polishing system shall be guaranteed for operation under the specified design conditions. Each filter polisher operating under normal service or design leak conditions with service runs terminated at high effluent cation conductivity or high-pressure drop across the filter polisher shall be guaranteed to deliver polished condensate having a quality equal to or better than that shown on the Specification Sheet included at the end of this section. During initial and subsequent startups and transient conditions, with the service runs terminated at resin/precoat exhaustion, the condensate polishing system shall be guaranteed to produce a water quality as specified on the Specification Sheet .

The Supplier shall be responsible for proper sizing of the equipment provided, including ample design margin. The Supplier shall be responsible for reviewing specified equipment to ensure that these items are compatible with the proposed design and equipment.

Filter Polishers. Each filter polisher shall be designed for a filtration rate of not greater than 3 gpm per square foot (7.3 m³/h per square meter) of bare filter element area.

All connections shall be flanged using ANSI weld neck flat faced flanges. Pad type flange connections or manholes will not be acceptable.

All internal parts subject to contact with the resin shall be of corrosion-resistant construction.

Adequate spacing between the filter elements and between the outer filter elements and filter polisher vessel sidewall shall be provided to ensure uniform flow during service runs and uniform distribution of the resin/precoat during precoating. The distance between coated filter elements shall be adequate to prevent bridging between cakes using either powdered ion exchange resin to a maximum loading of 0.6 pound per square foot (2.9 kg per square meter) of filter area or filter precoat to the maximum amount recommended for initial startup and subsequent restart operations.

Each filter polisher shall be provided with two sight ports located at the same elevation to enable an operator to illuminate the vessel interior through one sight port and observe the condition of the filter elements in the other sight port.

Holding Pumps. Holding pumps shall be furnished, one for each filter polisher. The pumps shall be sized to provide a constant flow of 0.5 gpm per square foot (1.2 m³/h per square meter) bare filter area minimum through the filter polishers.

Precoat Facilities. The precoat facilities shall be designed for manual preparation of the powdered resin/precoat slurry. The system shall allow for application of resin, precoat, or a combination of the two to the filter polisher filter elements.

Design of the system shall ensure protection of the low-pressure components of the precoat facilities from the pressure of the condensate system.

Precoat Tank. The precoat facilities shall include a precoat tank for preparing powdered resin or resin/precoat slurry. The tank shall be welded construction of 1/4 inch (6 mm) minimum thickness carbon steel. A platform adjacent to the precoat tank shall be provided for use in preparing the resin/precoat slurry.

The tank interior shall have an epoxy type phenolic lining extending through and on the flanged faces of tank connections.

The tank shall be sized to contain sufficient resin for one precoating operation to provide a minimum of 0.2 pound per square foot (0.97 kg per square meter) bare filter area and a maximum of 0.6 pound per square foot (2.9 kg per square meter) bare filter area, including sufficient precoat charge to precoat the filter polisher as recommended by the manufacturer for the specific operating conditions. The tank shall have sufficient freeboard to minimize overflow or spillage.

Precoat Pump. A precoat pump shall be furnished to transfer and recirculate the resin/precoat slurry through the filter polishers. The pump shall be designed to recirculate the slurry at a rate as close to the service flow rate as is practical considering the piping losses and slurry characteristics involved.

Body Feed System. A design for a system to inject resin/precoat slurry directly into the condensate inlet header shall be included. The direct body feeding of slurry will supplement the filtering capabilities of the filter polishers during periods of poor influent water quality such as condenser tube leakage or plant startup and restarts. The body feed system shall be designed to maintain the required condensate effluent quality during the worst influent conditions that may be encountered during service operation of the condensate polishing system.

A separate body feed slurry mixing tank shall be furnished to allow direct injection of slurry into the inlet header for the polishers in service while one polisher is undergoing backwash or precoat operations. The tank shall be sized according to the manufacturer's recommended application rate, based on the design conditions specified on the Specification Sheet at the end of this section. In addition to the mixing tank, the system shall include all pumps, piping, valves, and control components required by the design. Equipment proposed as part of the body feed system shall conform to applicable requirements included in these specifications.

System Control

All equipment shall be controlled from the powdered resin condensate polishing system control panel. All control, alarm, indication, and recording functions shall be included and furnished as part of the control system. The control system shall be PLC-based or DCS-based and shall use a CRT operator interface or traditional control hardware including switches, lights, indicators, recorders, etc. In addition, controls located in the Purchaser's main control room will be furnished by the Purchaser for remotely placing a vessel in SERVICE or HOLD mode.

Condensate Polisher Bypass Control. A full flow bypass system shall be provided to allow complete bypass of all condensate. The bypass system shall maintain full condensate flow as required by the main control system, but the valve shall be modulated to maintain the a set differential pressure across the condensate polishers to maximize the fraction of the condensate to be treated by the on-line vessels.

Provisions shall be included in the control system to fully open the bypass valve and activate the filter polisher holding pumps in the event of a plant trip or sustained period of highly irregular condensate flow. The bypass valve shall remain open until manually reset from the main control room.

Upon loss of control power or air, the inlet and outlet valves of the filter polishers shall remain in the position existing at the time of control power failure. All other valves shall close upon loss of control power or air.

The performance of the condensate polishing system shall be monitored continuously. Controls shall indicate and annunciate filter polisher exhaustion by high differential pressure and/or high effluent cation conductivity. The status of each filter polisher shall be indicated on the local control panel and in the main control room. Any abnormal shutdown, holding pump malfunction, or motor trip shall be annunciated on the local control panel.

Cation Conductivity Measurement

Samples from the effluent of each polisher will be piped to the water quality control system sample for continuous cation conductivity monitoring. Signals will be retransmitted to the condensate polishing system local control panel for indication and high effluent cation conductivity annunciation.

Powdered Resin Condensate Polishing Equipment Specification Sheet

Equipment Identification			
Percent of maximum flow rate to be polished	100		
Number of filter polishers required	3		
Percent capacity of each filter during normal operation	50		
Body feed system required	Yes		
Polisher vessel sight ports required	Yes		
Cation resin supply form	Hydrogen or Ammonia		
Anion resin supply form	Hydroxide		
Conditions of Operation	Normal Service	Leak Condition	Transient and Startup
Total dissolved solids, µg/L	50	200	200
Suspended solids, µg/L	Per Condenser Design	Per Condenser Design	Per Condenser Design
Ammonia (NH ₃), µg/L	800 to 2,000	800 to 2,000	800 to 2,000
Iron (Fe), µg/L	Per Condenser Design	Per Condenser Design	Per Condenser Design
Silica (SiO ₂), µg/L	20	75	500
Sodium (Na), µg/L	5	15	100
Chloride (Cl), µg/L	5	10	100
Note: Leak condition values must be calculated based on cooling water properties.			
Performance Guarantees			
Normal performance guarantees			
Total dissolved solids, µg/L	25		
Suspended solids, µg/L	10		
Iron (Fe), µg/L	5		
Silica (SiO ₂), µg/L	10		

Sodium (Na), µg/L	3	
Chloride (Cl), µg/L	3	
Cation conductivity, µS/cm	0.2	
Control System Design Data		
Control system type	PLC-based or DCS-based	
Electrical enclosures	Heated	
Control Functions	Control Function	Status Indication
Backwash pumps	Project Standard	Project Standard
Hold pumps	Project Standard	Project Standard
Precoat pumps	Project Standard	Project Standard
Annunciations	Local Annunciation	Remote Annunciation
Abnormal shutdown	Project Standard	Project Standard
Effluent cation conductivity high, each filter polisher	Project Standard	Project Standard
Differential pressure high, each filter polisher	Project Standard	Project Standard
Differential pressure high, each strainer	Project Standard	Project Standard
Loss of control air	Project Standard	Project Standard
Loss of control power	Project Standard	Project Standard
Bypass valve open	Project Standard	Project Standard
System differential pressure high	Project Standard	Project Standard
Recirculation flow low	Project Standard	Project Standard
Backwash or precoat step failure	Project Standard	Project Standard
Motor trip	Project Standard	Project Standard
Indications		
Filter hold	Project Standard	
Filter service	Project Standard	
Each backwash and precoat step	Project Standard	
Open position of each automatic valve	Project Standard	
Closed position of each automatic valve	Project Standard	

5.2.20 Closed Cooling Water System

Provide a closed cooling water system to supply cooling water to the various generation plant equipment heat exchangers and transfer the heat to air-cooled Component Cooling Water Heat Exchangers. The system must be capable of producing water temperature of 125°F or less at the maximum ambient temperature of 98°F. System shall be provided with all required equipment that will result in a complete, fully functional system.

Provide closed cooling water pumps with sufficient pumping capacity to supply cooling water to both GTG/HRSG trains, the steam turbine generator, and associated balance of plant equipment, at all operating conditions.

The Component Cooling Water System shall, as a minimum, utilize the following major equipment:

Equipment Item	Quantity	Capacity of Each Unit
Closed Cooling Water Pump	2	100% maximum system demand
Component Cooling Water Heat Exchangers	As Required	100% maximum system demand
Component Cooling Water Expansion Tank	1	As required

A duplex filter upstream of the closed cooling water heat exchanger shall be provided.

Rated water flow and system capabilities shall be based on sufficient cooling capacity for GTG/HRSG trains, the steam turbine generator, and associated balance of plant equipment, at all operating conditions.

All components shall be designed in accordance with the latest OSHA requirements. A vibration switch shall be supplied with the Component Cooling Water Heat Exchanger fan system to protect mechanical equipment against excessive damage due to

malfunction of the rotating members. Containment shall be provided for the component cooling water pumps, heat exchangers and expansion tank.

Design the component cooling water system for a mixture of no less than 45% propylene glycol solution. Provide concrete containment with drains around the CCW pumps with a 6-inch curb all around.

The system shall be designed and constructed so that one pump is started manually from the main control room and runs continuously during normal operating conditions. System operation shall be a permissive for GTG / STG operation. The other pump shall be on auto standby. A pressure switch in the pump discharge header shall be provided to initiate an automatic startup of the standby pump if discharge pressure is below a predetermined pressure setting. Selection as to which pump will be on standby shall be a manual operation.

The component cooling water expansion tank shall be designed to maintain the required system pressure, provide system make-up and accommodate flow variations, and allow system thermal expansion. The expansion tank shall be vented to the atmosphere and shall be located at the highest point in the system to provide adequate pump NPSH.

In order to prevent or minimize corrosion of any of the component cooling water system components, a corrosion control system shall be provided. The system shall be designed as a batch system in which the required chemicals are flushed into the system by means of a manually operated slug feeder.

5.2.21 Fuel Gas System

The fuel gas system shall receive gas from the plant metering station in a range of pressures indicated in Section 2 of these specifications. Provide all gas heating, moisture removal, particulate filtration, and pressure regulation required to deliver the gas to each individual GTG fuel gas control system and HRSG duct burner and pilot at the proper conditions as required by GTG and duct burner manufacturers.

Provide a check meter on the main gas supply to the Site as a secondary check to the natural gas supplier's revenue meter. Connect the meter to the DCS for historical

trending of the information and totalizing of the flow.

Fuel gas supply system shall be designed to ensure that the GTG manufacturer's fuel gas requirements for contaminants are met, given the worst case fuel that may be delivered to the facility; and to provide filtered, dry natural gas to the GTG and HRSG.

The Fuel Gas System shall be designed to meet all requirements and recommendations of NEC, NFPA, Factory Mutual, and local codes.

The fuel gas distribution system shall have sufficient capability to operate all GTGs and HRSG duct burners simultaneously at Peak output at any ambient condition with the design basis fuel gas composition defined in Appendix J.

Provide a fuel gas scrubber, primary and secondary (if required) fuel gas heaters, and a filter/separator for each GTG. The fuel gas scrubber shall be installed upstream of fuel gas heaters. Filter/separator should be installed downstream of the fuel gas heaters. Provide a filter/separator that is designed to satisfy the GTG manufacturer's limits on particulate matter and liquids. Each fuel gas scrubber and filter/separator shall come complete and skid mounted with automatic level control to maintain a safe level of accumulated liquids. Separated liquids shall be drained to collection tanks for subsequent removal. The drain tanks shall have level indication that is provided to the plant DCS. All materials in contact with the clean gas stream inside the filter/separators and downstream of the filter/separators shall be constructed of 300 series stainless steel materials.

Provide dedicated primary fuel gas heaters on each GTG unit. Primary fuel gas heaters shall be shell and tube heat exchangers, utilizing waste heat or low energy heat where possible as a heating medium. Design system to preheat fuel gas to a temperature required by the OEM under all load and ambient conditions prior to supply to the GTG fuel gas skid. Provide a temperature probe in the heated gas stream and temperature control valve in the condensate return line to afford temperature control of the natural gas. Scope of supply for the fuel gas heating system shall include, but not be limited to, heaters, heat exchangers, piping, valves, controls, drain tanks, expansion tanks, and safety relief valves.

Provide a secondary electric fuel gas heater on the fuel gas stream to each GTG, designed to provide fuel at the temperature required by the GTG manufacturer during startup (dewpoint heating).

Provide DCS controls and all instruments necessary to monitor temperature of fuel gas supply from the primary fuel gas heaters and automatically initiate and control the secondary fuel gas electric heaters to maintain the fuel gas temperature above the minimum allowed by the GTG manufacturer during start-up. Provide an alarm in the DCS for low fuel gas temperature.

Supply regulated gas, at the required GTG inlet supply pressure, to the GTG fuel gas control system. Provide all pressure regulation equipment required. Provide a branch line to the HRSG duct burners with pressure reduction control valves to reduce the inlet gas supply pressure to that required by the HRSG duct burners.

Provide flow measurement instruments on each fuel gas supply line to each GTG (meters are supplied with the GTGs) and each fuel gas supply line to each HRSG duct burner. Fuel gas metering to each duct burner and to each GTG shall meet the requirements of 40 CFR 75 for reporting.

The system shall be sized to meet the design capacity requirement with the gas supply pressures at minimum levels. The system design pressure downstream of regulators shall be at least 550 psig, but shall be selected by Contractor during detailed design based on the maximum gas supply pressure. Pressure safety relief valves shall be included as required to prevent the pressure from exceeding maximum system design pressure (including safety valve accumulation) or as required to protect supplied equipment or systems. Design temperature shall be equal to the maximum operating temperature plus a 10°F margin. Provide an automated emergency vent valve in addition to the safety relief valves. Provide a pressure switch with a set point sufficiently below the relief valve set pressure to close the site pressure regulators and open the emergency vent valve prior to lifting the relief's during a system upset. Locate and direct all vents (emergency and reliefs) away from buildings or occupied areas.

Natural gas supply to the Site will not be odorized. Therefore, provide natural gas detectors throughout the facility as required or recommended by NFPA, applicable codes, and as required by the local fire marshall.

Route all fuel gas piping so that piping is not below any ponds or permanent structures.

5.2.22 Compressed Air System

The compressed air systems shall be designed and constructed to supply filtered, dry, and oil-free compressed air to the plant service air system and to instrumentation and pneumatic control devices via the instrument air system. In addition, the following major equipment shall be provided to supply compressed air when the plant is out of service and during system start-up. Compressor and dryer shall be located next to the existing Block 1 air compressors skids. Both service air and instrument air shall be provided from a common air receiver. Air receivers shall be located as required by Contractor's design for Block 2 Equipment. New equipment shall tie into and be located adjacent to the existing Block 1 equipment.

Equipment	Quantity	Capacity
Air Compressor	1	100% Peak system demand
Service / Instrument Air Receiver	1	To level out demand on the Air Dryers and 10 minutes of demand (See Below)
Instrument Air Dryer	1	100% peak system demand

The air compressor shall have sufficient capacity to supply the maximum service air and instrument air required during normal operation and maintenance outages including adequate air to clean one of the GTG inlet air filter systems when the GTGs are shut down. The compressor shall provide oil-free (less than 0.05 ppm oil) air at a discharge pressure of 125 psig. Design system to maintain a normal supply header pressure of 115 psig and design all components to operate properly at a minimum supply pressure to each instrument and air user of 80 psig. Service air supply shall be provided with a low pressure cut-off.

Provide service air hose stations including 100 feet of hose within 100 feet of all areas requiring routine or periodic maintenance with compressed air tools or with compressed air.

Compressed air receivers shall be supplied with a relief valve and shall be ASME Section VIII, Division 1 code stamped and designed for 150 psig. Compressed air receivers shall be provided with sufficient volume to provide 10 minutes of air supply at the design demand rate without the pressure falling below 70 psig with all compressors failed.

The compressor shall be supplied with an inlet filter-silencer and discharged through an aftercooler and moisture separator. The compressor, intercooler, and aftercooler shall be air-cooled. The compressors shall discharge to the common desiccant type air receiver that is sized so that the compressors do not run continuously or in short cycle. The air receiver shall be designed to remove additional moisture.

The air compressors shall operate automatically to maintain the air receiver pressure within an acceptable range and shall be tied into the Block 1 system. In AUTO mode, the lead compressor shall start on low air receiver pressure and shall stop on high pressure. In the event that the lead compressor cannot maintain the minimum allowable pressure, the standby compressor shall start automatically, and a low-pressure alarm shall be activated in the main control room. A selector switch shall be provided in the DCS to establish the lead compressor and the standby compressors. Remote indication and set point selection capability shall also be provided in the DCS. Air compressor load shall be served off a critical service panel so that the compressor can be operated when the plant is down.

The compressed air stream shall be filtered and dried to a dew point of -40°F. A second receiver shall be supplied to level out instantaneous demand on the instrument air dryers. The desiccant type dryers shall be fully automatic and permit uninterrupted flow through the desiccant charge during regeneration. The instrument air stream flows through the heatless dryer, which shall include prefilters, afterfilters, and an arrangement of piping and manual isolation valves to allow continuous filtering during the replacement of one set of filter cartridges.

A pressure-regulating valve shall be provided to shutoff air supply to the service air system when low compressed air system pressure jeopardizes operation of the instrument air system.

5.2.23 Sampling and Analysis System

A sampling and analysis system shall be provided to monitor the performance and operation of the steam, condensate, and feedwater cycles; to monitor the quality of various process fluids; and to provide sufficient data to operating personnel locally and in the plant control room and to the plant DCS for detection of any deviations from control limits so that corrective action can be taken. The sampling and analysis system shall be located in a heated and ventilated enclosure near and readily accessible from the control room.

Each system shall be designed to condition samples by pressure and temperature reduction and to measure flow, temperature, pressure, cation conductivity, specific conductance and pH, silica, O₂, and sodium.

Samples shall be taken from various process points in each power block and routed to centrally located sample panels. At the panel, pressure reduction shall be accomplished by a "rod in tube" pressure reducing valves. Isolation valves shall be provided for each sample point on the sample panel to facilitate maintenance. Temperature reduction shall be accomplished by using sample shell and tube coolers utilizing closed loop cooling water for primary cooling of samples over 120°F. Provide a water-cooled (same cooling water as primary sample cooling water) chiller system for secondary cooling to control temperature to 77°F (+/- 1°F). Liquid sample tubing velocities will be approximately 3 to 6 ft/sec. Make provisions at the sample panel for pulling grab samples to allow the operator to perform wet chemical analysis in the laboratory. Sample wastes shall be directed to the boiler blowdown collection system.

The sample panel shall be logically laid out and clearly labeled. The systems shall be provided with quick disconnects to facilitate analyzer calibration and repair. Any sequencing controls shall utilize an Allen Bradley PLC.

The samples shall be directed to automatic analyzers mounted on the sample panel and the results displayed and recorded. The following sample points shall be included for monitoring, however all samples shall also have grab samples.

Service	GS	SC	CC	DC	DO	pH	Si	Na	
HRSG-A									
Condensate	X				P				
Boiler feed pump suction	X				P				
LP steam	X		X			X	P	P	
IP boiler drum	X	X	X			X			
IP boiler steam	X		X			X	P	P	
HP boiler feed water	X	X	X	X	X	X			
HP boiler drum	X	X	X			X			
HP boiler main steam	X		X	P		X	P	P	
Hot reheat	X		X						
Kettle boiler steam (if provided)	X	P				P			
Evap Cooler Sump*	X	P				P			
HRSG-B									
Condensate	X				P				
Boiler feed pump suction	X				P				
LP steam	X		X			X	P	P	
IP boiler drum	X	X	X			X			
IP boiler steam	X		X			X	P	P	
HP boiler feed water	X	X	X	X	X	X			
HP boiler drum	X	X	X			X			
HP boiler main steam	X		X	P		X	P	P	
Hot reheat	X		X						
Kettle boiler steam (if provided)	X	P				P			
Evap Cooler Sump*	X	P				P			
Common									
Condensate pump discharge	X	X	X	X	X	X	P	P	
Common hot reheat	X		P					P	
Make-up Demin	X	X					P	P	
Main steam	X								
Evap Cooler Makeup Tank*	X	P				P			
Common LP steam	X								
	GS	Grab Sample				Si	Silica		
	CC	Cation Conductivity				SC			
	DC	Degassed Cation Conductivity				DO			
	Na	Sodium				P	Patch Point		

All sample lines shall provide grab samples.

One boiler steam silica analyzer shall be provided to be shared between the high pressure and intermediate pressure boiler steam samples. One high purity silica analyzer shall be provided and shared by the high pressure and intermediate pressure steam samples. One dissolved oxygen analyzer shall be provided for analysis of either the condensate or boiler feed pump discharge samples.

All dissolved oxygen analyses shall be patched into one oxygen analyzer.

In addition to display of monitored values, visual and audible annunciation of abnormal water quality and chemical feed conditions shall be provided both locally and to the plant control room via the plant DCS. Recording shall be accomplished by the DCS for display in the main control room.

Sample lines and valves shall be designed and fabricated in accordance with requirement of systems from which they originate. The sampling and delivery piping, sample coolers, tubing, valves, and the sampling sink shall be of stainless steel construction to minimize corrosion. Sampling and delivery piping shall be heat traced and insulated as necessary to prevent freezing. Sampling and delivery piping shall be routed to prevent pockets or low points. Direct all blowdown from the sample analysis system to the boiler blowdown system. Steam sample connections shall be drawn with isokinetic sample probes.

Include personnel protective devices to protect personnel from all hazards.

5.2.24 Fire Protection System

Contractor shall provide two new 300,000 gallon fire water storage tanks for coverage of both the existing and new power blocks in accordance with NFPA 850. The existing raw/fire water tank shall be converted for raw water use only. The existing fire pumps may be re-used if adequate for serving both existing and new blocks or new ones shall be installed as required. Contractor shall connect the new system to the existing Block 1 underground fire water loop and provide a complete fire protection system that includes both Block 1 and Block 2 distribution systems, low-pressure CO₂ systems, FM 200

Systems, portable fire extinguishers, fire detection, alarm, actuation, and signaling systems. The fire water system capacity shall be at least equal to the flow rate required for the largest single fire hazard, plus a 500-gpm allowance for two hose streams. Contractor shall confirm that the existing system will meet this criteria with the addition of Block 2. In the event additional capacity is needed, Contractor shall add equipment and piping as required and include the costs for this equipment and piping in their proposal.

All fire protection systems and components shall be designed and supplied in accordance with the appropriate recommendations and requirements of NFPA, UL, FM, and the local Fire Marshall. The systems shall receive the approval of the Owner's insurance carrier.

The engineer responsible for the fire protection system shall be a practicing fire protection engineer registered as a Professional Engineer in the State of Utah. All drawings and specifications shall be signed and sealed by the Professional Engineer.

Should additional Fire Pumps be required, pumps shall be UL listed/FM approved and designed in compliance with NFPA 20 and 850 recommendations.

The underground fire main shall be a minimum of 10 inches in diameter and shall supply fire water throughout the generation plant area. The fire main shall be looped and shall supply water to fire hydrants, hose stations and fixed water suppression systems installed in buildings and elsewhere around the plant. Provide fire hydrants at a maximum of 250-foot spacing and protective ballasts around all hydrants.

The fire protection and detection systems requirements for specific plant locations are summarized in Table 5-2.

Fire protection during plant construction shall meet the requirements of NFPA 241. All fire protection systems shall be subject to review and approval of the local fire department authorities.

Fire walls, if required in Table 5-2, shall be in accordance with NFPA 850. All fire water piping and components that are exposed to freezing conditions shall be freeze

protected.

Portable CO₂ and dry chemical fire extinguishers shall be provided in all areas requiring handheld fire protection.

All local alarm, detection and suppression panels shall report status to the main fire alarm panel located in the control room. All alarms shall be indicated in the control room, as well as locally and as required by Code.

In addition to the other requirements, the following fire protection system features are to be incorporated into the design of the plant:

1. Oil Filled Generator Step-up and Auxiliary Transformers
 - A. Transformers shall be provided with oil containment and drainage to the plant oily water separator. Drain lines shall be provided with normally closed manual drain valves.
 - B. Transformers less than 50 Ft from buildings and other major equipment shall be provided with fire walls and automatic deluge system.
 - C. Fire walls shall be used between adjacent GSU and auxiliary transformers.
2. Steam Turbine Generator
 - A. Steam turbine lube oil tank/console shall be provided with automatic deluge system.
 - B. Steam turbine lube oil tank/console area shall be provided with oil containment and drainage to the plant oily water separator.
 - C. Steam turbine generator bearings shall be provided with automatic deluge system. Deluge system shall be designed to spray the bearings and the under deck area below the bearings where oil can accumulate.
 - D. Under deck area below the bearings shall be provided with containment and drainage to the plant oily water separator.
3. Buildings
 - A. Control room and electronic cabinets room (DCS I/O room) shall be provided with automatic FM 200 system. System shall be designed to

also protect area under computer floor.

B. All electrical rooms shall be provided with automatic FM 200 system.

4. Fuel Gas System

A. Gas detectors shall be provided for areas with non odorized fuel gas.

B. Duct burner management systems shall meet the requirements of NFPA 8506 and of the NEC code.

TABLE 5-2
Plant Fire Protection and Detection Systems

Plant Location	Type of Fire Protection	Fire Detection
Water treatment / chemical storage buildings	Fixed, automatic, wet-pipe sprinkler, closed head	Smoke/heat detectors
Chemical Feed Shelters	Handheld extinguishers*	Smoke/heat detectors
Sample analysis / CEM enclosure	Handheld extinguishers*	Smoke/heat detectors
Boiler Feed Pumps Enclosure	Handheld extinguishers*	Smoke/heat detectors
Steam turbine lube oil tank and lube oil piping	Fixed, automatic, dry-type, open head, deluge system	Heat detectors
Main (Generator Step-up) and station service transformers	Provide fire walls if located within 50 feet of other facilities, between adjacent GSU & auxiliary transformers or other major equipment	Fire walls
Gas turbine generator	CO ₂ system supplied by the GTG manufacturer	Supplied by the GTG manufacturer
Switchyard control building (Building is provided by others. Fire protection shall be provided under this Contract).	Handheld extinguishers or as required by the local fire marshal.	Smoke/heat detectors
Cable spreading vault/room	FM 200	
Gas Metering Building		

(*) or as required by local fire marshal

5.2.25 Potable Water System

Contractor shall tie the Block 2 potable water system to the existing Block 1 water treatment plant. Provide a potable water system for Block 2 to distribute potable water to various users located around the generation plant (See Conceptual Process Flow Diagram FD-2, Appendix D). Areas requiring potable water include various chemical storage areas and battery rooms requiring eyewashes and or showers around the plant. The operating pressure shall be controlled between 60 and 90 psig. Drinking fountains shall be included. The maximum potable system demand shall be determined in accordance with the Uniform Plumbing Code for the fixtures and shall include a 30-gpm allowance for eyewash stations and safety showers.

The potable water system shall be designed to provide potable water, both hot and cold as required, at the proper pressure, temperature, and flow rate to all plumbing fixtures and equipment. All instrumentation shall be controlled by the DCS. Potable water piping shall be insulated as required.

Provide back flow preventers on all service water branches off the potable water system.

Provide safety showers and eyewash station at all chemical storage locations, ammonia storage locations, in the battery room, at SCR ammonia injection skids, and otherwise where emergency showers are required per OSHA and where normally installed in a combined cycle power plant. Safety shower system shall be designed and constructed to meet OSHA requirements. Water supplied to the safety showers and eyewash stations shall be tepid per ANSI Z358.1 guidelines. Provide thermal relief valves on all safety showers and eyewash stations. Provide flow switches on all eyewash stations and safety showers. These flow switches shall alarm in the control room when flow is detected.

5.2.26 Process Bulk Gas Storage and Distribution System

The process bulk gas storage and distribution system described in this section is for use in the plant process systems and is in addition to the CO₂ fire protection system provided with the GTG or any other CO₂ fire protection systems provided at the request of the local fire marshal.

All process bulk storage systems shall be located under cover for sun protection.

The hydrogen storage and distribution system shall be provided to supply hydrogen for generator makeup during normal operation and for initial filling. Hydrogen will be stored in cylinders mounted on a mobile trailer to be provided by Owner's hydrogen supplier. Contractor shall provide a hydrogen storage trailer pad sized for two trailers. Contractor shall coordinate the design of the hydrogen storage system with the Owner's hydrogen supplier, install the complete system, including foundations and utility requirements, ready to receive the hydrogen gas and shall commission the complete system. A blast wall shall be installed between the hydrogen trailer and the occupied area of the plant to minimize personnel or equipment damage in the event of an explosion.

Contractor shall provide a bottled carbon dioxide distribution system to supply carbon dioxide for purging the generator casing to remove air and hydrogen during outages to prevent an explosive hydrogen mixture. Carbon Dioxide will be stored in cylinders mounted on a mobile trailer to be provided by Owner's carbon dioxide supplier. Contractor shall provide a carbon dioxide storage trailer pad sized for two trailers. Contractor shall coordinate the complete design of the carbon dioxide storage and distribution system with the Owner's carbon dioxide supplier, install the complete system ready to receive the carbon dioxide gas and shall commission the complete system with assistance as required from Owner's carbon dioxide supplier. The bottle storage trailers for Block 2 shall provide sufficient storage for four gas turbine generator purges. The Contractor shall provide a sun shelter over the bottle storage trailers.

Storage racks, manifolds, and pressure regulating stations for nitrogen gas bottles shall be provided and installed at each HRSG for the supply of nitrogen inerting gas. The nitrogen storage racks shall have sufficient capacity to blanket one wet HRSG for one month. The systems shall have sufficient capacity to adequately blanket a wet HRSG within 4 hours.

Nitrogen may also be supplied to the closed cooling water system head tank for pressurization as necessary for the Contractor's design. If required for other than long-term lay up of equipment, Contractor shall provide permanent facilities for Nitrogen storage.

Pressure control units shall be provided to regulate gas flow to meet system capacity requirements and satisfy minimum inlet pressure requirements at each user. The

system design pressures upstream of the pressure control valves shall be equal to the storage system's design pressure. The header pressure of each bulk gas system shall be monitored on the plant DCS. Provide relief valves downstream of the pressure control valve as required to protect the piping from a regulator failure.

5.2.27 Wastewater Collection and Transfer System

The wastewater collection and transfer system shall be provided to collect, treat, and dispose of the facility wastewater streams including the following:

1. Sanitary wastewater.
2. Oily wastewater.
3. Gas turbine water wash.
4. Process wastewater.
5. Wastewater discharge to evaporation pond(s).

All waste lift stations shall be open concrete sumps covered with solid dust tight covers. Sump pumps shall be installed in 100% capacity pairs. Sump pumps shall be vertical sump pumps with the motor installed above the sump solid dust tight covers.

5.2.27.1 Sanitary Wastewater

The sanitary wastewater shall be collected from the various points of origin in the facility and disposed of in the existing drain field septic system. Contractor shall confirm whether existing Block 1 facilities are adequate for the addition of Block 2. The system shall be sized to meet the requirements of local code. A pumped system shall not be used unless a gravity system is impractical. Contractor shall tie into the existing Block 1 system as required.

5.2.27.2 Oily Wastewater

Plant wastewater that has the potential for oil contamination shall be collected and routed through an oil/water separator. An oil/water separator shall be provided in accordance with the following paragraph:

Oil/water separator shall be a double-wall vessel in accordance with API 421 standards and UL 58. Separator shall include sufficient corrosion protective coatings or shall be fiberglass and shall be provided with a minimum of two manways for access to the front

and back portions of the separator. Extend manways to grade and provide gasketed covers. Design internal components requiring maintenance to be removable from the manways. Provide separator capable of removing entrained oil to a maximum instantaneous concentration of 10 ppm or as required by the plant permits, whichever is more stringent, and hardwired to the DCS if historical data archiving and/or trending is required by the permit. Provide level probe and high level switches and interstitial leak detection devices between the vessel walls. This system shall be designed so that a vacuum truck can remove separated oily waste.

5.2.27.3 GTG Water Wash

The GTG water wash system shall be provided with two (2) concrete sumps, one for each GTG, sized to contain the wastewater from two complete GTG water wash cycles. The tank system shall be provided with connections and designed for vacuum truck removal.

5.2.27.4 Process Wastewater

Process wastewater including waste from the water treatment system, RO reject from the cycle makeup treatment system, oil/water separator, and HRSG blowdown shall be drained to a collection sump. Hot process drains shall be cooled before introduction into the hot drain system. Hot drain piping shall be designed to accommodate temperatures up to 212°F.

The plant wastewater discharge shall be monitored and measured as required by the plant wastewater permits and all applicable federal, state, and local codes. Provisions shall also be made to provide grab samples. Provide sample connections on the waste discharge piping to each pond to facilitate the collection of grab samples. All other waste streams shall be directed to the locations indicated above.

5.2.28 Heating, Ventilating, and Air Conditioning System

The heating, ventilating, and air conditioning (HVAC) systems for the plant shall satisfy the workspace environmental requirements for personnel occupancy and equipment operation. Temperatures shall be maintained well below operating limits so that equipment reliability will not be jeopardized.

The ambient design conditions for the HVAC Systems shall be selected by the Contractor based on ASHRAE data for the plant location.

HVAC systems shall be designed to maintain the indoor conditions listed in the table shown below based on the maximum ambient temperatures.

Building/Area	Outdoor Ambient Design	Indoor								System Configuration
		HVAC Design Temperature		Humidity Control (%RH)	Ventilation Rate Based on a 10F rise	Particulate Filtration Efficiency (%)	Pressurization	Redundancy (Note 4)	Noise Criteria	
		Winter (F)	Summer (F)							
Electrical Equipment Area	Note 1	72	75	30-65	N/A	High/Low	Positive	2 x 100%	NC 45	AC for equipment requirements
Battery Room	Note 1	60	Note 2	N/A	As required For 2% hydrogen Dilution	None	Negative	2 x 100%	85 dBA	Heated and ventilated for equipment requirements. Explosion-proof construction
Electronics Room	Note 1	72	75	30-65	N/A	High/Low	Positive	2 x 100%	NC 45	AC for equipment requirements
Water Treatment Building	Note 1	60	Note 2	N/A	Note 2	None	None	None	85 dBA	Heated and ventilated for equipment.
Chemical Storage	Note 1	60	Note 2	N/A	Note 2	None	None	None	85 dBA	Heated and ventilated for equipment.

Instrument Shop & Prefabricated Electrical Enclosures	Note 1	72	75	30-65	N/A	Medium	Positive	None	NC 45	AC for personnel comfort and equipment requirements
CEMS Shelters	Note 1	72	75	30-65	N/A	Medium	Positive	2 x 100%	NC 45	AC for personnel equipment requirements
Boiler Feed Pumps Building	Note 1	60	Note 2	N/A	Note 2	Medium	None	None	85 dBA	Heated and ventilated for equipment
Sample Analysis Shelters, Chemical Feed Shelters	Note 1	60	Note 2	N/A	Note 2	None	None	None	85 dBA	Heated and ventilated for equipment.
Offices (outside of admin area)	Note 1	72	75	30-65	N/A	ASHRAE STD-62	Positive	None	NC 45	AC for personnel comfort and equipment requirements

Notes:

1. 1997 ASHRAE Fundamentals, 1% summer/99% winter for Salt Lake City, UT.
2. Indoor temperature is the greater of the following: Ambient temperature plus 10F or the equipment temperature limit.
3. Evaporative "swamp" cooler shall be designed for a minimum of 85% effectiveness.
4. Redundancy is included to specify the amount of redundancy required (e.g. 2x100% requires a primary system with a 100% back-up system and None requires only a primary system). Redundancy does not specify the number of units required to accomplish the intended duty. However, unless approved otherwise by the Owner, a maximum of three air-conditioning units shall be used to accomplish any single application for which no redundancy is specified and a maximum of four air-conditioning units shall be used to accomplish any single application for which redundancy is specified.

The design table indicates the level of redundancy for HVAC equipment in the indicated areas. When redundancy is indicated, only the major active components require backup equipment. Static components such as ductwork do not require duplication.

Minimum ventilation rates shall be provided in normally occupied areas in accordance with local codes. In the absence of applicable local codes, ASHRAE Standard 62 requirements will be met.

The air conditioning for control and electrical equipment shall be designed to meet the filtration levels indicated in table shown below. Tabulated filtration levels are indicated as low, medium, or high. These levels are according to the following filtration efficiencies as defined by ASHRAE Standard 52, Method of Testing Air-Cleaning Devices Used in General Ventilation for Removing Particulate Matter:

<u>Level</u>	<u>Efficiency (percent)</u>
High	80 to 90
Medium	55 to 65
Low	Less than 20

Noise criteria are indicated in the design table as NC levels, decibels, or as background. Noise criteria (NC) values are as indicated in the ASHRAE Handbook series for acoustical design criteria. Decibels are sound pressure levels, A-weighted, to a reference of 0.0002 microbar (0.00002 Pa), at 5 feet (1,500 mm) from the equipment as measured in a free field with a single reflecting plane. Background indicates that the HVAC equipment will be designed such that the contribution shall be 2 dB or less than the overall room noise at 6 feet (1,800 mm) above the floor with normal plant equipment in operation.

Mechanical equipment rooms containing refrigerants will be designed in accordance with the requirements of ASHRAE Standard 15, Safety Code for Mechanical Refrigeration.

A minimum of five air changes per hour of ventilation or recirculation air will be provided for effective mixing during heat removal ventilation or air conditioning.

Laboratory design ventilation rates shall be based on local codes. If local codes are not available, ASHRAE STD-62 will be used.

Maximum design temperatures represent the average building temperature. Cooler temperatures may occur near the ventilation inlets and higher temperatures may occur at relief and exhaust points.

The indoor temperature design conditions in the control building and electronics enclosures shall be in accordance with equipment operating requirements. The indoor and outdoor design temperatures in non-process areas shall comply with applicable local energy code requirements. As a minimum air-conditioning systems be designed to maintain and indoor temperature of 70 degrees F. Heating systems shall be designed to maintain comfortable space temperatures during normal winter plant operations

Ventilation systems shall be designed to provide adequate ventilation air to dissipate the excess heat developed by the plant equipment and components during plant operations. Ventilation systems for chemical storage areas shall be designed in accordance with Industrial Ventilation Standards to keep chemical concentrations in the air within acceptable limits.

The battery room ventilation system capacity shall be based on limiting the maximum hydrogen concentration to 2% or less of the total battery room volume while maintaining an acceptable internal temperature. Battery room air shall be exhausted continuously by a spark-proof exhaust fan (with a spark-resistant fan wheel and explosion-proof motor) to maintain a low level of hydrogen concentration. Provide a hydrogen detector for the battery room and connect to the DCS, either directly or through the fire detection system.

Air velocities in ducts and from louvers and grills shall be sufficiently low so to maintain acceptable noise levels in areas where personnel are normally located. Roof ventilators shall be low noise type to minimize impact of plants overall noise emissions.

Thermal insulation with vapor barrier shall be provided on ductwork surfaces with a temperature below the dew point of the surrounding atmosphere to prevent vapor condensation. All ductwork used for air conditioning purposes shall be insulated: ductwork used for ventilation purposes shall not require insulation.

Exhaust systems shall be provided for toilet and shower areas. Outdoor ventilation air shall be based on normal room occupancy or local codes, whichever is more stringent.

5.3 PLANT PIPING REQUIREMENTS

5.3.1 General Requirements

This criteria covers the requirements for the design, fabrication, installation, and protection of all plant piping. Contractor shall be responsible for the mechanical design of the piping system, pipe stress analysis, and pipe supports. Upon request, all design criteria and calculations shall be provided to Owner for review.

All piping shall be designed, fabricated, installed, examined, and tested in accordance with applicable local codes and the applicable sections of ANSI B31.1 for power piping, B31.3 for fuel piping, and the ASME Boiler and Pressure Vessel Code, Section I for critical boiler related piping

Process pipe sizing shall be based on the following factors:

1. Maximum line velocity as defined in Table 5-1.
2. Piping layout and configuration.
3. Economic evaluation considering piping material cost and pumping energy costs.
4. Quality of material handled (clean, sedimentation, other).
5. System operation (continuous or intermittent).
6. Minimize flashing, noise, vibration, water hammer, deflection, and erosion over the full range of operation, including startup and shutdown.
7. Minimum pipe size shall be 3/4 inch, except for connections to equipment. Pipe sizes 1-1/4 inch, 3-1/2 inch, 5, 7 and 9 inch shall not be used except for connections to equipment.

All potable water piping shall be sterilized in accordance with AWWA standards for disinfecting purposes prior to filling.

Run all lines parallel to building lines and equipment centerlines. Group parallel lines to the greatest extent possible for support from a common pipe support system.

General service piping shall be installed with north/south runs at one elevation and east/west runs at another elevation. Where change in direction occurs a minimum of 1 foot 6 inches (3 feet on lines above 6-inch NPS) elevation change shall be provided. Exceptions to this requirement will be allowed on the main steam piping (HP steam, Hot Reheat, Cold Reheat, and LP steam.)

Provide sufficient unions and flanged connections to permit dismantling of equipment, automatic valves, and instruments for routine maintenance.

Slope all vent lines and gravity drain lines to provide a minimum of 1/8 inch per foot slope in the direction of liquid flow.

Pump suction and discharge piping shall be at least one pipe size larger than pump connection. Provide spool pieces between pump and isolation valves to permit removal of the pump without removing block valves. Install eccentric reducers with flat side on top at all pump suctions. Do not install pockets in piping on pump suction that would trap liquids. Pump suction piping shall be in accordance with Hydraulic Institute recommendations.

Provide steam drain assemblies at all pocketed low points, at dead ends, and at intervals along main steam lines to be determined by Contractor to ensure adequate condensate removal during system warm-up and compliance with ASME TDP-1.

Provide spare valved instrument air taps on instrument air line a minimum of every 20 feet where instrument air headers are routed through or along equipment. Provide valved taps every 50 feet in general pipe rack runs.

Provide service air and water hose stations within 100 feet of all areas around the plant that may require air or water for maintenance or washdown. Route 1-inch minimum lines to the hose stations. Terminate all hose stations with a quarter turn ball valve and "Chicago type" hose coupling.

Provide plugs or caps in all valved connections open to the atmosphere.

All lines filled with a liquid that could freeze under extended shutdowns which are not freeze protected as required in the Insulation and Jacketing section of these Specifications, shall be designed and provided with sufficient drains and vent valves to allow fully draining as a means of freeze protection. Drains and vents on such piping shall be designed to be safely accessible from grade or elevated platforms.

All above ground piping shall be metallic unless specifically approved by the Owner. Above ground pipelines 2-1/2 inches and larger shall be provided with an identification system indicating the pipe contents and direction of flow. The identification system shall be easily visible and readable from floors or platforms. The system used by the contractor shall be approved by the Owner.

The exterior of exposed carbon steel piping that is not insulated or galvanized shall be cleaned and painted.

Piping shall be carried on overhead pipeways, sleeperways, or lined trenches. Space for electrical and instrument conduit runs shall be provided on the pipeways and sleeperways as required. Space for electrical and instrument conduit runs shall be segregated to eliminate electrical interference.

Pipe routing shall allow unobstructed maintenance of plant equipment.

Piping shall not be installed above, or within a horizontal distance of 3 feet (1 m) from, electrical equipment such as switchgear, switchboards, control panels, motor controls, contactors, communication equipment, batteries, battery chargers, and motor generators unless written consent of the Purchaser is obtained. Improperly located piping shall be removed and relocated.

All branch piping shall be provided with shutoff valves at the main headers.

Valves shall be installed in such a manner that they can be operated from the main operating floors or platforms without the use of ladders or special operating devices.

Pipe runs that require condensate drainage shall be installed so that they pitch toward

the point of drainage.

Piping subject to freezing shall not be routed in the vicinity of large doors which could be open for the moving of mobile equipment or maintenance.

Where building expansion walls are anticipated, piping shall not be supported from or located on columns or beams on these walls.

Piping indicated on P&IDs or other drawings as having a connection for the future extension of the piping to another unit shall be routed to a convenient point along the column row adjacent to the unit or the location for a future unit.

Underground metallic piping shall be provided with corrosion protection based on the recommendation of a certified corrosion engineer for the piping material and measured soil resistivity. Underground piping shall be routed following designated corridors, rather than the shortest path. The firewater loop piping and potable water piping shall normally be routed underground. All underground piping shall be provided with brightly colored marking tape installed per manufacturer's recommendations along entire length of pipe with colors and markings appropriate for its service. Non-metallic piping shall utilize metal detectable marking tape.

Condensate, feedwater, and steam lines shall not be installed below grade.

5.3.2 Piping Classes

The Contractor shall furnish specifications identifying the piping classes for the major systems. The class description shall include service description, pressure/temperature rating values and materials, descriptions, types, and ASTM specifications for fittings, flanges, branch connections, welding, gaskets, bolting, pipe, and bends.

A general listing of minimum piping materials that shall be used for each service is provided in the following table. To the extent that there is any conflict between the piping materials listed below and any other provision of these Specifications, except code, the piping materials shall have priority. Contractor is responsible for ensuring the materials specified are suitable for the intended service and shall substitute higher quality materials where required to meet the intended service life of the plant. All substitutions shall be approved by the Owner.

PIPING MATERIALS		
<u>Service</u>	<u>Media</u>	<u>Material</u>
Ammonia	Aqueous Ammonia	ASTM Type 316 SS
Boiler Blowdown	Treated Water	ASTM A53 GR. B or A106 Gr. B or Alloy Piping as required for the application, SMLS
Chemical Treatment Acid Tubing	Sulfuric Acid	ASTM B468 UNS N08020, Alloy 20, Fully Annealed, SMLS with a hardness of Rb95 or less. Fittings to be flareless type.
Closed Cooling Water	Treated Glycol Solution	Above Grade: ASTM A53 GR. B or A106 Gr. B., ERW or SMLS Below Grade: ASTM D1248, D3350, & F714, HDPE per ASTM D3350 class 345434C.
Compressed Air Piping	Air	ASTM A312-TP304, Fully Annealed, Stainless Steel or ASTM B88 Hard Tempered (Soft annealed if used with ferrule tube fittings), Type K, Copper
Compressed Air (Instrument tubing)	Air	ASTM A213, Type 316, Fully Annealed, SMLS, Stainless Steel with a hardness of Rb80 or less or ASTM B75, Soft Annealed, SMLS, Copper Fittings to be flareless type or Victaulic Stainless Steel Pressfit piping system.
Condensate	Water	ASTM A106 Gr.B, SMLS.
Demineralized Water	Water	Above Grade: ASTM A312-TP304L, seamless, Fully Annealed, Stainless Steel Below Grade: ASTM D1248, D3350, & F714, HDPE per ASTM D3350 class 345434C
Drains – Cold	Water	ASTM D1248, D3350, & F714, HDPE per ASTM D3350 class 345434C

Drains – Hot	Water	Ductile-Iron, AWWA C151, Soil Pipe, Mechanical Joints or A53 Gr. B ERW
Feedwater	Water	ASTM A106 Gr.B, SMLS.
Firewater	Water	Above Grade: ASTM A53 GR. B or A106 Gr. B, ERW or SMLS, Galvanized Below Grade: ASTM D1248, D3350, & F714 High Density Polyethylene (HDPE) per ASTM D3350 class 345434C and Factory Mutual Approved for 200 psig W.W.P.
Lube Oil, seal oil (Supply Piping)	Oil	ASTM A312 GR.B, TP 304 H, SMLS, Stainless Steel
Natural Gas	Natural Gas	<u>Upstream of Filter Separator</u> ASTM A106 Gr.B, SMLS <u>Downstream of Filter Separator</u> ASTM A312-TP 304 L, SMLS, Stainless Steel
Potable Water	Water	Above Grade: ASTM A53 GR. B or A106 Gr. B, ERW or SMLS, Below Grade: ASTM D1248, D3350, & F714, HDPE per ASTM D3350 class 345434C
Raw Water	Water	Above Grade: ASTM A53 GR. B or A106 Gr. B ERW or SMLS, 2-inch diameter and less to be Galvanized. Below Grade: ASTM D1248, D3350, & F714, HDPE per ASTM D3350 class 345434C.
RO Water	Water	Above Grade: ASTM A312-TP304L, seamless, Fully Annealed, Stainless Steel Below Grade: ASTM D1248, D3350, & F714, HDPE per ASTM D3350 class 345434C
Sample Tubing & General	Steam &	ASTM A213, Type 316, Fully Annealed,

Chemical Tubing	Condensate Samples and General Chemicals	SMLS, Stainless Steel with a hardness of Rb80 or less Below Grade: ASTM D1248, D3350, & F714, HDPE per ASTM D3350 class 345434C.
Sanitary Waste	Sanitary Waste	Cast-Iron Soil Pipe, Hub & Spigot or ASTM D1248, D3350, & F714, HDPE per ASTM D3350 class 345434C.
Softened Water	Water	Above Grade: ASTM A53 GR. B or A106 Gr. B ERW or SMLS, 2-inch diameter and less to be Galvanized. Below Grade: ASTM D1248, D3350, & F714, HDPE per ASTM D3350 class 345434C.
Steam	Steam	Seamless Steel or Seamless Alloy Piping as Required for the Application
Wastewater	Wastewater	Above Grade: ASTM A53 GR. B or A106 Gr. B, ERW or SMLS Below Grade: ASTM D1248, D3350, & F714, HDPE per ASTM D3350 class 345434C.

All tubing shall be free of scratches and suitable for bending and flaring. ASTM B88 copper tubing used with ferrule type connections shall not be embossed on the exterior. Tubing wall thickness shall meet or exceed the recommendations of Swagelock for use with Swagelock tube fittings.

Carbon steel lines 2 inches and smaller shall be schedule 80 minimum. For 2 inch and smaller alloy steel lines, minimum wall thickness shall be calculated based on design conditions. For 2-½ inch and larger, the minimum wall thickness for carbon steel pipe shall be standard weight.

Design pressure of piping systems shall be a minimum 20 psig above the maximum pressure anticipated during operation or 50 psig, whichever is greater. Where piping is directly or indirectly connected to the discharge of a pump, the maximum operating

pressure shall be the maximum pump shut-off head. Design temperature of piping systems shall be a minimum of 15°F above and below the maximum and minimum temperatures anticipated during operation.

Include a 1/16-inch corrosion allowance on all carbon steel piping.

Piping 2-½-inch NPS and larger shall utilize butt-welded construction unless flanges are required. Fire water piping does not require butt-welded construction.

Ammonia piping shall be of welded construction. Connections to equipment and instruments may be threaded. All other piping shall be of welded construction, except small bore service water and potable water. Victaulic couplings are allowed on above grade fire protection systems.

All above ground piping shall be metallic unless specifically approved by the Owner.

5.3.3 Line List

During the project design phase the Contractor shall prepare a piping line list showing line number, originating P&ID number, points of origin (i.e. line or equipment), points of destination, classification, size, insulation symbol and materials, flowing media, operating and design pressure and operating and design temperature.

5.3.4 Clearances

Good design practice shall be followed to assure proper clearance between piping equipment and passageways for operation and maintenance. Proper space shall be provided to service control valves and their operators. Special attention shall be given to provide access for cranes or other equipment handling devices. Clearances shall be provided as specified in the Access and Clearances section of these Specifications.

Provide sufficient clearance between lines to permit access for repair or removal. Clearance between pipe and flanges, fittings, or insulation on adjacent pipe shall not be less than 6 inches. Where pipe is insulated, clearance shall be between insulation and flanges, fitting or insulation on adjacent piping.

5.3.5 Piping Stress Analysis

As a minimum, all piping having a design temperature of 250°F or greater shall be

subjected to the piping stress analysis.

Piping analyses shall be performed either by computer or by simplified methods as allowed by piping codes and shall consider:

1. Thermal expansion.
2. Deadweight and hydrotest loads.
3. Steam hammer and relief valve thrust.
4. Equipment manufacturer's allowable nozzle loads.
5. Wind load for piping routed outside.
6. Seismic requirements.

The piping flexibility analysis shall be based on a system's design conditions of pressure and temperature encountered during startup, normal operation, or shutdown. To these operating design conditions, industry accepted conservative margins (safety factors) of temperature and pressure shall be added. Also, the analysis shall consider the maximum temperature differential. The effect of installation temperature and solar temperatures shall be considered in determining the maximum temperature differential.

Computer analysis shall be performed on all piping covered by ASME Boiler and Pressure Vessel Code, Section I and all condensate, feedwater, and steam piping 2-1/2 inches and larger. Other pipe stress analysis methods may be used for the analysis of other plant piping systems. The following industry accepted methods can be used: Grinnel, Tube-Turn, Kellogg, Spielvogel, Flex-Anal Charts, Guided Cantilever.

The piping loads at the equipment nozzles shall be limited to equipment manufacturer's allowable loads. If equipment manufacturer's allowable loads are not available, the piping loads shall be limited to the following levels: Cast connections - 50 pounds per nominal inch; forged connections - 200 pounds per nominal inch (not to exceed 2000 pounds). The actual calculated load shall be forwarded to the manufacturer for concurrence.

5.3.6 Pipe Bending

Pipe bends may be used. Carbon steel pipe may be hot bent or cold bent. Field bending of stainless steel pipe will not be allowed. Bending of carbon steel below 1,300° F is considered cold bending. For hot bending, pipe shall be heated to a temperature not exceeding 2,000°F. No hot bending or forming shall be performed at temperatures below 1,650°F. Bending radius shall not be less than five times nominal pipe size unless approved by Owner. Wall thickness of pipe and metallurgy after bending must meet applicable code requirements for specified design conditions.

5.3.7 Pipe Sleeves

All pipes passing through walls, floors, roofs, decking, and grating shall have sleeves provided. Sleeves shall be sized and have clearances to allow for packing and sealant installation. Sleeves shall be 18-gage carbon steel except that sleeves 8 inch and larger shall have ¼-inch minimum wall thickness. Where pipe movement is anticipated or pipe size is subject to change, larger sleeves shall be used. All floor sleeves shall be anchored with lugs or similar devices. The annular space between the pipe and sleeve at wall and floor penetrations shall be packed with fiberglass. Where penetrations are in walls or floors designed for fire separation, special sealants and packings designed specifically for the application and to meet the fire separation requirements as required by the applicable NFPA codes shall be used. Firestopping materials shall be in accordance with applicable ASTM or UL standards.

5.3.8 Dissimilar Metal Joints

In all cases (except for air systems) when a piping connection is made between steel and aluminum or copper, the mating surfaces shall be electrically isolated. For 2 ½-inch and larger piping, flanges shall be used, and the flanged joint shall be made using an electrically non-conducting gasket and flange bolts fitted with plastic ferrules and plastic washers under the bolt heads. Two-inch and smaller connections may be made using flanges, as stated above, or with dielectric type couplings, bushings, or unions.

Electrically isolated joints shall also be employed at all points where above ground piping meets piping from below ground.

5.3.9 Equipment for Plant Start-up

Temporary piping and supports shall be furnished for chemically cleaning the HRSG and

steam blowing. The piping that connects to the steam turbine valves shall be turned over to the Owner for future use.

Silencers shall be used during all steam blowing operations to minimize noise. Silencers are not required to be turned over to the Owner.

All pumps shall be furnished with start-up strainers and with the fittings for their easy installation and removal.

5.3.10 Sewer and Underground Piping

The Contractor shall ensure the entire plant Site is adequately and properly drained. Paved plant operating area shall be sloped from high points and catch basins shall be provided for storm runoff where required.

Vessel and other equipment drains shall interconnect with the plant drainage system and not the storm system. Sewers and drain lines shall run in the general direction of collection or disposal without sharp angles or turns. The minimum size of underground drain lines shall be 4 inches. Buried steel lines shall be coated and wrapped for corrosion protection. Cathodic protection and/or coating and wrapping shall be provided for all underground piping such as vessels and metallic equipment in contact with the earth. Cathodic protection methods shall be recommended by a Corrosion Engineer after reviewing the Geotechnical data for the Site and shall be approved by the Owner

5.3.11 Vents and Drains and Manholes

All piping high points shall be vented and all piping low points shall have drains. The minimum vent and drain line size shall be ½-inch or larger as required. Manholes shall be provided as required by final design.

5.3.12 Root Valves

Root valves shall be of standard gate or globe pattern, mounted with stem upright or horizontal, unless otherwise specified. Root valves shall be positioned as follows:

1. Gate valves – stem upright (preferred), or as nearly upright as conditions permit, but in not case below the horizontal.
2. Y-pattern globe valves – stem upright (preferred), or as nearly upright as

conditions permit, but in no case below the horizontal.

3. Special valves – including remotely operated solenoid and control valves, shall be mounted in accordance with manufacturers' recommendations.
4. No valve shall be mounted with the stem below the horizontal centerline.

Root valves shall be double blocked in services greater than 600 psig or 800°F.

5.3.13 Root Connections

Root connections on horizontal or sloping lines shall not be located below the horizontal center of the line. The following rules shall be observed:

1. Root connections for service on steam and condensable vapors or wet gas shall be taken from the top or side of the pipe or from any point between the top and the side.
2. Root connections for service on liquids shall be taken only from the side of the pipe, with the root nipple horizontal.
3. Root connections for service on dry gases shall be taken from the top of the pipe.
4. All root nipples shall be as short as possible, in standard lengths. Room shall be allowed for free manual operation of the valve without the hand or fingers coming into contact with the surface of the pipe or its insulation. Root nipples, longer than 6 inches end-to-end shall not be used.

Welded thermowells shall be installed according to code requirements. Threaded thermowells shall be installed in threaded bosses. Thermowells and piping in which thermowells are installed shall be designed specifically for the application to prevent cycling and fatigue of the thermowells.

5.3.14 Fabrication Requirements

Fabrication shall be in accordance with the specified Codes. All piping materials shall be in accordance with good engineering practice and all piping and fittings shall be new and clean.

Fabrication tolerances shall be in accordance with good engineering practice.

Tolerances shall cover general dimensions such as face to face, end to end, or end to center. Tolerances shall not be cumulative.

Weld reinforcements shall be held to a minimum and edges shall merge smoothly with the basic metal without undercutting. All repairs shall be made with matching weld metal and edges shall merge smoothly with the basic metal with no undercutting. The welding procedure shall be established by Contractor and submitted for review to Owner and shall be in conformance with applicable codes.

5.3.15 Shop Cleaning

Cleaning of surfaces, which are not to be painted or coated shall be done according to the supplier's best recommended practice, and it shall achieve the cleanliness level described by the acceptance criteria and the specific requirements described below.

Parts of subassemblies that may have crevices or inaccessible surfaces after assembly shall be cleaned as well as practicable, prior to assembly.

All cleaning operations shall be conducted so that stainless steel and nickel alloys are not contaminated with lead, copper, mercury, and/or other low melting point metal; chlorides, sulfur, halogens, as well as ferritic steel materials.

Abrasive blasting may be used on raw, unmachined casting, forging, or plate only.

5.3.16 Inspection

Contractor shall be responsible for inspection of all fabricated piping material. Owner reserves the right to inspect fabrication at any time. Contractor shall maintain qualified personnel to inspect shop and field fabrication for material specifications, dimensional accuracy, fabrication techniques, and quality.

5.3.17 Protection for Shipment and Construction

All flange faces, machined surfaces, and threads shall be clean and shall be protected from damage during shipment. Flange faces and machined surfaces shall be protected with wood or metal covers. Couplings and threads shall be protected by steel pipe plugs or by plastic protectors. Pipe shall be cleaned and supplied with end caps prior to shipping. All protective coverings and end caps shall be maintained in place until the component is erected and open ends or faces replaced between installation shifts.

5.3.18 Welding

All welding, welding procedures, and welder qualifications shall be in accordance with all applicable and specified Codes. Contractor shall qualify all welders. Each welding procedure shall include a welding procedure qualification test report.

Welding shall not be performed on materials that are below a minimum temperature of 50°F (at the weld-affected zone) and surfaces to be welded shall be free of moisture prior to welding.

The maximum interpass temperature when welding austenitic stainless steel shall be 350°F.

Field butt weld ends on shop fabricated piping and components shall have end preparations dimensioned in accordance with ANSI B31.1 and B16.25. All welding end preparations made in the field shall be in accordance with the requirements stated above.

Integral attachments welded to piping shall be of the same P-number material groups as the piping material. Attachments, which are shown on the piping Drawing or which require post-weld heat treatment shall be welded in the piping fabricator's shop. All other integral attachments shall be welded in the field. Integral attachment on piping having design temperatures of 600°F or higher shall be attached by full penetration welds except riser clamp shear lugs which may be attached with fillet welds.

Backing rings shall not be used in any service.

All root passes on butt-welded steam, boiler feedwater, condensate, and cycle make-up water shall be made using the gas tungsten arc (GTAW) process.

5.3.19 Field Installation

Piping shall be assembled and installed in accordance with the applicable sections of the specified Codes. Contractor shall take special care that the installed piping is free and clear of all foreign materials, construction debris, etc. All welds shall be clean and free of burrs and slag.

Installation and orientation of all gauge glasses, live controllers, thermometers, thermocouples, pressure gauges, and similar items shall be arranged for convenience of operation and ease of maintenance.

Pipe insulation shoes shall be adjusted so that they are centered over pipe supports in the hot position after the line is completely installed and brought into operation.

5.3.20 Pipe Supports, Guides, Restraints, and Anchors

The following requirements shall govern the installation of pipe supports for large bore and small bore piping systems.

5.3.20.1 General Requirements

All pipe supports shall be installed in accordance with MSS-SP58, MSS-SP69, ANSI B31.1 and B31.3, AISC, and AWS D1.1.

Pipe supports shall be constructed of ASTM A36, ASTM A992, Grade 50, or ASTM A500 carbon steel, or alloy steel components as required by pipe materials or process conditions.

Surfaces to be welded and surfaces up to 1 inch from the edge of the weld shall be clean and free from oil, rust, scale, paint, and other deleterious materials.

Installation of the permanent hangers at the time of pipe installation is required. Hangers shall be installed so that their nameplates are visible and accessible.

All hanger components shall be given a 3-mil prime coat of inorganic zinc paint.

The spacing of hangers and supports for steel piping shall not exceed the values recommended by ANSI B31.1.

All hanger components shall support the piping in the normal operating position and during hydrostatic test, shall allow for the expected expansion or contraction except where anchored and guided, and shall not cause excessive stresses in the piping or excessive loads on the connected equipment.

Standard stock or production parts shall be used where possible. The recommended

load ratings and limitations in manufacturer's hanger catalogs shall not be exceeded.

For critical systems accurate weight balance and thermal movement calculations shall be made to determine the required supporting force of each hanger and the limits imposed upon each equipment connection. The weight balance for all hangers shall include the weight of the pipe, fittings, valves, the medium transported, the insulation used, and the suspended portion of hanger assemblies and pipe attachments. Spring hanger assemblies shall be designed to support the piping under normal operating conditions. All hangers and components, however, shall be designed to supporting the piping system during hydrostatic test.

No support shall utilize other piping systems for attachment. Hangers shall not be attached to flange, valve, or equipment bolts or to equipment. Hangers shall be a minimum of 6 inches away (in either a hot or cold position) from any flange and shop or field pipe welds.

Adjustable type pipe supports shall be used at all pump suction and discharges.

Supports installed on concrete slabs or pads shall be installed on a minimum of 1 inch of grout. Use shims to bring supports to elevation. Jack nuts shall not be used.

5.3.20.2 Attachments to Piping

Integral attachments shall be used only where non-integral attachments are impractical at Owner's discretion. Where necessary, symmetrically loaded clamps with shear lugs welded to the pipe 90 degrees apart shall be used. Localized stresses, induced by external forces into the pipe wall, shall be analyzed in combination with all existing pipe stresses to ensure that total stress levels are within code allowable values.

Integral attachments shall be of the same P-number material group as the piping.

Non-integral attachments to piping shall be of design and materials suitable for the entire range of operating temperatures of the piping system.

Clamps used as the attachment to piping components in a strut assembly shall have a minimum spring rating equal or greater than five times the strut spring rating.

For insulated lines at 750°F and below, pipe clamp MSS Type 3 or clevis hanger MSS Type 1 with an MSS Type 39 insulation protection saddle shall be used. All voids in the pipe covering protection saddles shall be filled with insulation. Supports on insulated piping shall not penetrate the insulation lagging. For lines with no insulation, pipe clamp MSS Type 3 or 4 or clevis hanger, MSS Type 1 may be used. Riser clamp MSS Type 8 shall be used on all risers.

For lines that are heat-traced and lines that have an operating temperature below 70°F, the use of clamps or attachments in direct contact with the pipe shall be minimized to the greatest extent possible. Except for unusual situations, which require attachments in direct contact with the pipe, the attachments or clamps shall be outside the thermal insulation. For horizontal pipe, the thermal insulation shall be protected by means of pipe covering protection saddles, MSS Type 39, and pipe clamps or clevis hangers sized to fit on the insulation OD. All voids in the pipe covering protection saddles shall be filled with insulation.

5.3.20.3 Attachments to Structure

Reduction of the effective strength of any structural member shall not be permitted. Structural attachments to steel shall be designed to support the maximum calculated loads. For attachments to the supporting steel on hangers for pipe sizes 2 ½-inches and larger, beam attachments MSS Type 22 shall be used within the limitations of loads. For piping 2 inches in diameter and less, where relatively small movements are expected and where hangers are normally not engineered, MSS Type 23 may be used. Where sliding supports or other integral base attachments are supported on a concrete floor, an anchored or fixed steel base shall be provided as a sliding surface.

Structural attachments should be made to steel whenever possible, whether to structural steel or to steel embedment plates or inserts in structural concrete. When necessary to use drilled-in-place bolts in concrete, only wedge type anchor bolts such as HILTI Kwik-Bolts, or equal shall be used, and the connection shall be carefully designed using the allowable loads including the effect of combined tension and shear loads, spacing, and embedment depths.

No attachments should be made to anything but structures.

Anchors, supports, restraints, and guides shall be designed to prevent the transmission

of temperatures in excess of 300°F to building steel and 150°F to concrete. This determination may be made by using a reduction factor of 100°F/inch from the outside surface of the uninsulated pipe for all parts in direct contact with or welded to the pipe.

5.3.20.4 Spacing

Support points shall be selected on the basis of proper location and spacing for optimum load distribution and weight balance, taking into consideration the available building structure and load distribution from which hangers can be suspended.

The spacing of hangers and supports for steel piping operating at temperature above 750°F shall not exceed the values given in ANSI B31.1. The above maximum spacing figures are applicable to straight piping runs. Additional supports shall be provided for concentrated loads such as valves, strainers, or other in-line items. At changes in piping direction, supports shall be located at, or immediately adjacent to, the change in direction to the greatest extent feasible, and the spacing to the next support beyond the change in direction shall be appropriately less than the maximum spacing of supports permitted for straight piping runs.

Vertical pipe should be supported directly with riser type hangers rather than having the weight of the riser supported by adjoining horizontal pipe.

The maximum support spacing recommendations of the nonmetallic or nonferrous pipe manufacturer shall not be exceeded.

5.3.20.5 Pipe Support Identification

The Contractor shall submit the pipe support identification system to the Owner for its approval.

5.3.20.6 Anchors, Restraints, and Sliding Supports

Anchors, guides, and restraints shall be capable of supporting the pipe and resisting dead loads plus any expansion or contraction thrusts that may be imposed by the piping.

Anchors required for expansion joints shall withstand the longitudinal pressure force plus the joint-spring force and sliding friction force. The longitudinal pressure force shall be calculated as the product of the hydrostatic test pressure and the maximum internal transverse area of the joint. Guides for expansion joints shall direct piping movement

into the joint within the joint manufacturer's allowable lateral and angular misalignment limits.

Sliding supports and guides shall be designed to withstand the induced friction force in addition to other loads on the support. Dry lubricant surfaces (i.e., Teflon or UHMW) may be used to reduce the friction force. Preformed graphite or carbon shall not be used.

Corners and edges of metal slides and guides in sliding supports shall be rounded or chamfered, and guide parts shall be designed with sufficient length so that binding within the necessary clearance will not occur.

5.3.20.7 Hanger Rods

Hanger rods shall be sized in accordance with ANSI B31.1. Hanger rod diameters shall be 3/8-inches minimum on 2-inch and smaller pipe and 1/2-inch minimum on piping 2-1/2-inch and larger and shall be compatible with the other component parts of the hanger assembly and subjected to tension stresses only. Where horizontal movement is anticipated, the rod shall be fitted with eyes, links, or swivels to permit unrestrained swinging of the rod. Un-welded eye rods shall not be used. Where anticipated piping movement would cause hanger rods to be more than four degrees out of plumb, the hangers shall be offset in the erected position to provide vertical alignment when the piping system is in operation. Hanger rod lengths shall be calculated to provide for at least plus or minus 3 inches of rod adjustment subsequent to hanger erection.

Maximum length of rods shall be 20 feet. Minimum rod length shall be 15 inches for each inch of horizontal movement.

5.3.20.8 Variable Spring Hangers

All variable spring hangers shall be selected for operation at or about the mid-load range. The length of spring and the spring scale shall be selected so that variation in the supported load due to temperature differences does not exceed 25% of the dead load; otherwise, constant support hangers shall be used.

The working range of variable spring hangers shall account for all load movements as well as for thermal movement. A minimum of 1/2-inch additional travel beyond the maximum and minimum values at the working range shall be provided after final field

adjustments.

Variable spring hangers shall be of the enclosed helical, pre-compressed type with the end coils ground flat and square with the spring axis. Travel stops shall be factory installed, so that the piston cap is set at the “cold” position. The travel stop shall be easily identified and removable but shall act as a “rigid” hanger during erection and hydrostatic testing. To avoid misplacement of a travel stop, it shall be attached to the spring unit by means of a cotter pin and chain or equivalent. Variable spring hangers shall be calibrated by a dynamometer and the load affixed to the housing. The unit shall then be adjusted to the proper ambient position to suit the travel it is to accommodate and the position plates locked. The locked unit shall be capable of supporting at least two times the normal operating load. When the loads induced by hydrostatic testing exceed the spring capability, temporary supports shall be installed. Each variable spring hanger shall have a travel and load scale plate, red and white markers to indicate the design hot and cold positions, respectively, and a travel indicator. The red and white markers and the travel indicator shall be easily visible at a distance of not less than 30 feet and visible from the ground or platform. The hanger type, mark numbers, and calibrated load shall be die-stamped on each hanger nameplate.

5.3.20.9 Adjustment and Locking Devices

All supports shall have screw adjustments accessible and workable when fully loaded. Threaded members shall have a true and complete depth of thread. Nuts, clevises, sleeves, turnbuckles, and related items, shall have their full length of thread in complete service while in use and the amount of male thread available for adjustment plainly visible; sight holes shall be provided for visibility in parts where necessary. Eight pitch series threads will be permitted only when the supplier furnishes both mating parts. All bolts on hangers shall be double-nutted. Hanger rods shall have a locking nut on each end of the turnbuckle.

5.3.20.10 Inspection

When the piping is being put into service, the hangers shall be inspected by Contractor’s qualified inspectors to insure the pipe is moving as intended and is not causing the hangers to deflect against travel stops or exceed load or travel scale.

When the system has reached maximum normal operating temperature, the spring hangers shall be inspected and, if necessary, adjusted to the hot or calibrated position

indicated on the hanger. If a hanger is deflected to its stop, it shall be adjusted immediately so that it will carry load on the spring and not on the stop. In making such adjustments, care shall be exercised to avoid adjustments which will result in a hanger deflecting against stops or off-the-load or travel scale as the pipe cools during a shutdown. If such a condition is unavoidable, the hanger must be replaced with one of proper size.

5.3.21 Painting

Un-insulated, above grade, structural and miscellaneous carbon surfaces shall be shop blasted and primed in accordance with Section 7. Surfaces shall also be finish painted and color coded with colors selected by the Owner.

Carbon steel piping which is installed underground shall be coated with one of the following:

1. Prime with Type B primer and coat with coal tar enamel and non-asbestos felt wraps per AWWA C203. Finish with one coat of water resistant whitewash.
2. 12-inch and smaller: Coat with mill applied polyethylene plastic coating, Entec or X-Tru-Coat, or owner approved equal.
3. Shop applied tape wrap. Tab shall consist of butyl-based adhesive with polyethylene backing (similar to Polyken 930, Protecto Wrap 310, or Tapecoat CT)

Consult the services of a corrosion engineer to recommend further corrosion protection based upon the soils condition. Submit the corrosion engineer's recommendations to the Owner for information and acceptance of the recommendations. Provide cathodic protection for underground piping as recommended by the corrosion engineer and as approved by Owner.

All labeling of piping will be provided by Contractor with an Owner approved system.

5.3.22 Testing

Hydrostatic testing shall be performed after piping is completely installed. Test pressure shall be in accordance with the specified codes. Care shall be exercised by the Contractor to protect vessels, equipment, and instrumentation which can be damaged during pipe pressure testing through the use of slip blinds or other suitable means.

5.4 VALVES

This section details the technical requirements for furnishing, delivering, and installing butterfly, globe, gate, check, plug, and ball valves. The Contractor will complete valve data sheets and specify all valves in accordance with the requirements of this section.

5.4.1 General Requirements

All hand operated valves 2-inch and smaller for throttling service shall be globe valves unless service requires other specific types.

All control valves shall have a bypass valve and isolation block valves. Bypasses installed around liquid service equipment shall use globe type.

Isolation valves shall be provided for all piping connections to equipment.

Isolation valves for pump suctions and discharges shall be located in the larger piping sections.

Manually operated valves shall be located to be accessible from grade or elevated platforms such that operation can readily be performed or, where this is impossible, chainwheel operators shall be provided on manual valves. Valves shall be provided with a minimum of one handle length or handwheel diameter clearance between handle or handwheel in all positions and the nearest obstruction.

Install valves with stems vertical, wherever practical. Where not practical, stems shall be horizontal or above.

Install valves with indicators visible from accessways or elevated platforms wherever possible.

Valve operators shall not extend through floors or platforms so as to create a tripping hazard.

All instruments and gauges that are not in-line, except flow switches and temperature elements, shall be supplied with root valves for isolation during maintenance.

All temperature elements and gauges shall be provided with thermowells constructed of materials suitable for the service.

5.4.2 Valve Materials

All valves and valve materials shall be chosen as to be suitable for the intended service fluid, temperatures, pressure, and flows. Good engineering judgement shall be used at all times. The yoke or intervening structural member(s) between the valve and operator shall be of an ASTM material.

A graphite packing system (e.g., Grafoil ribbon pack with corrosion inhibitor, using end rings of braided graphite filament) is preferred. Alternate asbestos-free packing systems compatible with the intended service, shall be submitted to the Owner for approval.

5.4.3 Valve Shop Painting

Corrosion-resistant valve surfaces shall not be painted or treated with a rust preventative.

Exposed external ferritic steel surfaces of the valve assembly shall be painted with one coat of the manufacturer's' standard primer, except for machined working surfaces or adjusting nuts, bolts, or studs which shall be coated with a rust preventative, suitable for providing up to 1-year corrosion protection under outdoor storage conditions.

5.4.4 Lubricant Materials

Replacement lubricants, where required, shall be in accordance with manufacturer's requirements.

5.4.5 Design Requirements

Butterfly valve design shall be to, and meet the requirements of, MSS SP67, Type I, for tight shutoff.

Steel gate, globe, and check valves 2-½ inch and larger shall be designed and constructed in accordance with ANSI B16.10 and B16.34.

Steel gate, globe and check valves 2 inches and smaller shall have their pressure ratings in accordance with ANSI B16.34 and shall be of forged material.

Gate and globe valves shall have bolted packing gland and a fixed backseat.

Bronze valves shall be designed, manufactured, and inspected in accordance with MSS-SP80.

The stem finish in the area which will contact the packing shall be 32 rms or better. The stuffing box wall shall have a 125 rms or better finish. When required, seals shall be provided to retain grease and keep dirt and moisture out of bearings. Alemite lubricating fittings shall be furnished to lubricate bearings, yoke nuts, or bushings.

All forgings shall be clean and free from unacceptable defects. Repair of unacceptable defects is not allowed on forgings.

Valves of the same size, type, material, and pressure/temperature rating shall have interchangeable parts in order to reduce spare parts inventory.

Ball valves shall be in accordance with MSS SP72, and ANSI B31.8.

Ball, plug, and butterfly valves shall have blowout proof stems whose retention shall comply with ANSI B16.34, Paragraph 6.5.

Preferably, all ball valves shall be of top entry type so that the ball and seals can be replaced in the body without removing the valve from piping during maintenance. However, alternate types will be considered, provided the design does not require cutting piping to remove the ball and seals. Submit alternates for Owner's approval.

Plug valves shall be designed to the requirements of the API-6D. Plug valves shall be wrench or gear-operated, and of the tapered plug, self-lubricating sleeve, or reinforced seat type.

Flanged and weld-end valves shall conform to the face-to-face and end-to-end dimensions of ANSI B16.10 for each respective pressure class.

The valve and operator assemblies shall be designed and assembled so critical parts cannot become disengaged due to vibration and/or assembly orientation. Particular

attention should be given to drive keys to assure that they are locked or “captured” by means other than press fits or the use of adhesives.

5.4.6 Valve Operators

Select valve operator and install valve to allow operation of valve without interference with adjacent piping or equipment without valve operator disassembly.

Provide gear operators for ball, plug, and butterfly valves 6 inches and larger.

If smaller valves require more than 60 lb of force applied to the manufacturer’s standard lever, the Owner shall be advised as to the force required to operate and options available (e.g., lever length), so it can be determined whether a gear actuation is required.

Gate and globe valves shall be provided with the manufacturer’s standard operator or handwheel for seating the valve.

Valves with gear operators shall be provided with a protective pipe and/or pipe plug on the operator, as appropriate, to protect the stem/stem nut from dirt, debris, and other matter. Operating valves installed at an elevation of more than 6 feet 9 inches between the bottom of the handwheel and grade or an elevated platform shall be furnished with a chain operator for operation from grade or elevated platforms. Install chain operators such that chain hangs within 2 feet of the operating level and can be “tied off” on a nearby structure so as to keep the chain out of the operating aisles.

Block valves used only for isolation in shut downs or repairs that are accessible by portable ladder need only be supplied with chain operators if installed at an elevation of more than fifteen feet between the bottom of the handwheel and grade.

Operating valves installed with handwheels under platforms shall be supplied with extensions for operation above the platform. Handwheels shall extend upward beside the platform and not through the platform

Supply quarter turn valves with locking devices on the handles.

Provide valve handle extensions of extended bonnets on valves installed in pipelines

designated to be insulated. Handle extensions shall be suitable to provide a minimum of 2 inches clearance between the handle and the outside of the insulation jacket.

5.5 INSULATION AND JACKETING

5.5.1 General Requirements

This section covers the requirements for the selection and application of insulation systems for plant equipment and piping. Contractor shall be responsible for determining the economical insulation thickness and selecting the appropriate insulation material.

Provide illustrations and instructions for field installation of insulation for piping, valves, vessels, and equipment that is not pre-insulated by the supplier.

Provide removable insulation and jacketing sections at all flanged joints in insulated piping. Install removable sections to allow entire flange studs to be removed from either side of joint.

Insulation on valves shall be extended to include the valve bonnet.

5.5.1.1 Insulation

Minimum insulation thickness shall be 2 inch.

Provide an insulation specification thickness table and specification summary sheet indicating materials, manufacturer, material thermal properties, and application requirements for each insulation system proposed. Table shall indicate required heat conservation insulation thickness for each nominal size of piping and duct and for equipment for each 100°F temperature increment in the range of 200°F to 1100°F. Table shall also include insulation thickness for burn protection for each NPS and equipment components in the same temperature range and for anti-sweat insulation for each NPS and for equipment.

All outdoor piping shall be insulated and freeze protected OR self draining unless approved by Owner. Use removable insulated jackets on control valves and large isolation valves. Freeze protection should be extended at least 12" below the frost line for the site. Insulation and jacketing to be repaired after construction.

All piping or equipment filled with a liquid that could freeze under normal operation or during a shutdown at the coldest ambient temperatures recorded during a consecutive 3 day period over the last 10 years, shall be heat traced and insulated as required to prevent freezing under such conditions. Such lines shall include, but not be limited to instrument tubing, chemical tubing, sample analysis piping, boiler trim piping, boiler and steam line drain piping, fuel gas header flex couplings to burners on duct burners, and service water piping to utility stations. Heat tracing shall be installed completely to delivery point, such as blowdown tanks. All heat traced tubing shall be integrally heat trace tubing / heat tracing bundles.

Provide heat conservation insulation on all piping and equipment operating above 200°F for which heat loss is not desirable. Insulation thickness shall be determined by an economic analysis of the cost vs. energy savings for the ambient conditions. Provide insulation to maintain an average surface temperature of any insulated lines below 140°F with an ambient temperature of 80°F, an emissivity of 0.09, no incident solar heating, and a 5 mph wind. Components requiring insulation shall include, but not be limited to, the following:

1. All steam piping.
2. Boiler feedwater pumps and piping.
3. Condensate piping (after condensate enters the preheaters).
4. Natural gas pre-heater gas side piping downstream of the heater.
5. Feedwater piping feeding and returning from natural gas pre-heater.
6. HRSG steam drums and trim.
7. HRSG casing including all transitions.
8. HRSG exhaust stack.
9. All other lines with an operating temperature above 140°F.

Provide anti-sweat insulation on piping installed in areas where the ambient dew point could be below the surface temperature of the piping at any conditions within the operating range of the plant.

Provide personnel protection insulation on all surfaces operating above the OSHA limit which are accessible from grade, ladders, or elevated platforms. Personnel protection insulation shall extend to a level of 7 feet (minimum) above grade or platforms and 3 feet (minimum) beyond any handrail.

Insulation materials shall have a flame spread rating of 25 or less, when tested in accordance with ASTM E84. Where installed inside building, insulation shall have a smoke density of 50 or less, when tested in accordance with ASTM E84. Select insulation materials to be suitable for the intended service in accordance with the National Insulation Association standards. Ceramic fiber insulation should be used where temperatures exceed the allowable limits of calcium silicate. Use elastomeric rubber, polyethylene, or polyisocyanurate foam insulation on cold service piping for anti-sweat applications. Anti-sweat applications shall include a continuous, unbroken, vapor seal. Outdoor anti-sweat insulation not provided with a jacket, shall be painted in accordance with insulation manufacturer's recommendations.

Use cellular glass insulation on all hot piping requiring insulation, which is installed in an area prone to flooding (either due to rainfall or from process upsets).

Insulation installed on stainless steel shall be limited in chloride content and shall meet the latest revision of military specification, Mil-1-24244B. Certification test is not required; however, manufacturer shall guarantee that insulation meets this standard.

Provide removable blanket insulation on all manways, removable covers, control valves, automated valves, engineered valves, and instrumentation installed in insulated piping systems. Transmitters and other remote mounted instrument shall be supplied with O'Brien, pre-fabricated, insulated instrument enclosures with quick opening latches. Removable blankets shall be 1-inch minimum thickness for temperatures to 250°F, 2-inch minimum thickness from 250°F to 500°F, and 3-inch minimum thickness above 500°F. Use stainless steel speed lacing hooks or stainless steel D-rings with fabric straps.

Insulation application including mastics and coatings shall be in accordance with insulation manufacturer's recommendations and the National Insulation Association standards.

Insulation installed in areas subject to foot traffic shall be designed to prevent collapse of the insulation.

Provide insulation support rings on vertical piping 6 inches and larger with spans greater

than 10 feet. Maximum spacing between support rings shall be 10 feet.

Acoustic insulation shall be designed and applied to piping and equipment where required to meet the noise limits specified in Section 1.

5.5.1.2 Jacketing

Provide jacketing systems on all insulated equipment and piping, except those insulated with elastomeric rubber or polyethylene. Install jacketing to prevent the entry of moisture. Jacketing materials shall be as follows:

Equipment:	0.036 inch thick (minimum), corrugated, embossed, aluminum with vapor barrier
Piping and valves:	0.02 inch thick (minimum), corrugated, embossed, aluminum with vapor barrier

Use stainless steel or aluminum bands with wing seals to hold jacketing in place.

Seal all penetrations in jacketing with mastic cement and weather tight flashing.

Seal all breaks in insulation that would be exposed upon removal of flange insulation, equipment insulation, instrument insulation, or removable jacket insulation. Seal end caps using aluminum flashing and mastic.

Apply jacketing in accordance with insulation and jacketing manufacturer's installation instruction.

SECTION 6.0

CIVIL SCOPE

6.1 GENERAL REQUIREMENTS

This section covers the minimum scope and quality for the plant civil design and construction.

Contractor is responsible to inspect the Site, obtain all necessary Site data, perform all required additional geotechnical investigations, and determine all Site data for the design and construction of the power plant. This shall include determination of local code requirements for seismic and wind design loads. It is Contractor's sole responsibility to ensure that the building foundations and Site work comply with all federal, state, and local code requirements and all industry codes and standards.

All waste material removed from the Site shall be properly disposed of by Contractor.

The scope shall include, but not be limited to the following:

1. Clearing and grubbing.
2. All subgrade facilities and preparation.
3. Site drainage during construction.
4. Permanent drainage system.
5. Construction wastewater disposal.
6. Site grading including rough grading of the switchyard area.
7. Construction of all foundations and structures.
8. Permanent and temporary roads.
9. Evaporation Ponds.
10. Site Security.
11. Off-site Road Improvements and repair (if required to transport or receive equipment or if required as a result of construction work).

The Project design shall take into account existing Site conditions with respect to soil

characteristics, Site clearing, grading, and drainage. The Contractor shall be responsible for all Site preparation including any demolition, soil stabilization, grading, drainage, fencing, roadways, and parking areas.

6.2 SITE PREPARATION AND MAINTENANCE

Contractor is responsible for all Site preparation, backfill, and excavation. Cut and fill for the entire site, including the ponds and switchyard, shall be managed by Contractor.

6.2.1 Site Preparation

The Site shall be properly leveled with no construction debris or dirt piles. Contractor can store native material on Site that is suitable for use as backfill. Consideration shall be given to drainage to ensure no low lying areas are left, which would accumulate water. Installation of Site construction utilities shall be planned and constructed by Contractor. Location shall be approved by Owner.

6.2.2 Site Clearing and Grubbing

Selectively clear the Site of all trees, debris, rubbish, shrubs and vegetation as required for construction of new facilities. Effort shall be taken to ensure that as much as possible existing vegetation remains undisturbed. All debris from clearing and grubbing shall be removed from the Site. All root mats and stumps shall be completely removed and holes refilled with select material and compacted adequately for the ultimate expected loading for the material used.

6.2.3 Drainage

The working areas of the Site shall be well drained during and after construction. The Site drainage plan and discharge of drainage from the Site shall conform to federal, state, and local laws and regulations. All drainage shall be away from the buildings at a minimum of 1/4-inch per foot for the first ten feet. Design storm for culverts and storm sewer shall be for the peak flow rate for the 25-year 24-hour duration storm and shall be checked for flooding for a 100-year 24-hour duration storm.

6.2.4 Erosion

Contractor shall provide for erosion control during and after construction in accordance with Project permits, local and state laws and regulations, and local practice. Best management practices such as check dams and sedimentation basins shall be used during construction to minimize erosion. Drainage facilities shall be designed and

constructed in a manner to minimize erosion.

6.2.5 Debris

All construction-related debris and unsuitable material shall become the immediate property of Contractor and shall be removed from the premises and lawfully disposed of off-Site by Contractor.

6.2.6 Road Maintenance

All temporary access roadways used by Contractor shall be maintained in serviceable condition. Contractor shall keep the surfaces of those roadways free from spills, mounds, depressions, and obstructions which might present a hazard or annoyance to traffic. Block 1 and Block 2 roads shall be tied together.

6.2.7 Excavation, Filling, and Backfilling

Excavated native material may be used on the construction Site for embankment, if suitable. All rock, concrete, wood, metal, and other materials from the excavation shall be removed from the Site by Contractor. To the extent possible, backfill and subgrade fill will utilize excavated materials. Under-slab and bedding material, topsoil, and other materials from off Site borrow areas shall be the responsibility of Contractor. Site dewatering during construction is the responsibility of Contractor.

6.2.8 Site Grading

Grades shall be established to minimize the amount of earthwork required to construct the facilities. All areas disturbed during construction shall be graded to a smooth surface and (covered with appropriate material as conditions require). Finish grading will be performed to conform to the finished design elevations for surface drainage and to prepare the areas to receive the specified surface finishes.

6.3 SITE IMPROVEMENTS

Paving and fencing improvements shall be in accordance with the Site plan and detail drawings included in the Appendices. Final design shall be shown in detail on Contractor's final plot plan. Paving design criteria shall be:

1. Subgrades shall be constructed of material with CBR of 4 or better, if available.
2. Design life shall be 35 years.

3. The construction period will produce 70 to 80 percent of the maximum wheel loads for the design life.
4. Structures supporting pavement shall be designed to support H-20 standard highway loads.
5. Pavement design shall be in accordance with AASHTO or other Owner approved procedures.

6.3.1 Storm Water Drainage System

A storm water drainage system shall be used to collect all rain water from the Site that is not potentially contaminated by oil and or other chemicals (non-active areas). Building roof drains will drain into this system. The storm water drainage system shall drain into the local drainage system. Provide suitable facilities and access for sampling of the storm water leaving the Site.

All rain water collected from active areas that can be contaminated by oil shall be contained and routed through an oil/water separator as described in the Mechanical Scope Section before release to evaporation ponds.

6.3.2 Sanitary System

The sanitary sewer system shall consist of drain piping, septic tank, and leaching fields on the Owner's property, if required. Contractor shall confirm whether existing Block 1 facilities are adequate for the addition of Block 2.

6.3.3 Fencing and Gates

Security fences, where applicable, are to be constructed 7-foot high standard galvanized chain link fence with 3 strands of barbed wire. Gates, as required for vehicular access, will be a minimum of 2 sections, each 10 feet wide.

6.3.4 Crushed Stone Surfacing

All general plant areas that do not require paving or landscaping shall be surfaced with compacted aggregate finish 6 inches thick. The areas within the substation fence will be finished by Others with crushed stone or gravel.

6.3.5 Buildings and Equipment Foundation

Building and equipment foundations shall be of reinforced concrete including all formwork, rebar, waterstop, and related items.

6.3.6 Tank Foundation

Tank foundations shall be either reinforced concrete slabs or reinforced concrete ring wall foundations with a compacted sand bottom within the ring walls.

6.3.7 Manholes

Manholes shall be provided as required by final design.

6.3.8 Duct Banks

Underground banks of power and instrument conduit shall be encased in concrete. Encasements shall be reinforced when ducts pass under roadways, traffic, or heavy maintenance areas. The top of the concrete shall be colored red.

6.3.9 Landscaping

Areas to be disturbed but does not contain foundations, paving, or other surfacing shall be stabilized and protected from erosion by topsoil and seed or other erosion control measures. Seed mixture shall be suitable for local conditions.

6.3.10 Roads and Parking

Subgrade preparation and compaction shall be in accordance with Sound Geotechnical Engineering Practice. Geogrid and limestone may be used for subgrade improvements. Paved roads and surfaces shall be paved as described below, unless state or local codes and standards specify more stringent requirements.

Roadways and paved areas shall be designed for AASHTO HS20 loading as a minimum. Paving may be either reinforced concrete or asphalt concrete and shall be designed based on the value of the modulus of subgrade reaction (k) determined for the site. Concrete paving shall be used in maintenance areas and for roadways subject to heavy maintenance cranes, parked trailers, or delivery trucks. Asphalt paving will be acceptable for roadways not subject to heavy load traffic. The laydown areas shall also be designed with consideration for concentrated loading due to handling of loads such as turbine rotor removal. Temporary construction roadways will be designed and surfaced to meet the heavy loads of moving the turbine and generators on steel wheeled dollies.

In general, roads shall have a minimum one way lane width of 12 feet, and a two-way

total width of 24 feet. All roads shall have 3 feet wide shoulders. Minimum radius of curvature shall be 45 feet. All roads shall have a 2% slope from the crown with shoulders sloped at 2%. All other paved areas shall pitch a minimum of 2% to drains.

6.3.10.1 Roads

Roads on-site shall conform to the following:

Description	No. Lanes	Lane Width	Shoulder Width	Surface
Access Road	2	12 ft	3 ft.	Paved
Plant Island Perimeter	2	12 ft.	3 ft.	Paved
Building Driveways	1	Width of Door Plus 2'	-	Paved
Equipment Access	1	10 ft.	-	Paved

Applicable Specifications:

Utah Department of Transportation's Standard Specifications for Road and Bridge Construction

Subgrade Preparation:

Subgrade shall be proof rolled five (5) passes of a 10-ton vibratory roller (minimum), or as required by additional geotechnical analysis.

Pavement:

Road pavement shall be in accordance with the State of Utah Department of Transportation's Standard Specifications for Road and Bridge Construction, and final geotechnical report.

Design Traffic Number, DTN = 50

Design Vehicle = HS20

Construction Loading

Horizontal and Vertical Curves:

Horizontal and vertical curves shall meet the Federal Highway Administration and AASHTO standards.

The inside edge of paved surfaces at intersections shall have a minimum radius of 45 feet inside the plant.

Vertical curves shall be as flat as practicable; minimum sight distance shall be 500 feet inside the plant roads.

6.3.10.2 Parking Areas

Parking facilities shall be provided for plant personnel and visitors. Parking shall meet requirements for the physically handicapped as required by federal regulations such as the American with Disabilities Act. Car stops, parking lines, and lighting shall be provided. Contractor shall provide additional parking stalls as directed by Owner.

Provision shall be made within the fenced areas for parking in accordance with the local zoning ordinances.

6.3.10.3 Plant Area Surfacing

Asphalt Paving –	Roads and Parking Areas
Crushed Limestone Base (minimum 8”), Crushed stone shall be clean, uniform with a minimum of 95% of stone greater than 3/4”	Area inside loop road, air cooled condenser and transformer area, and other equipment areas as required
Rip Rap – As a minimum, stone shall have an average of weight of 120lbs/cubic feet and average size of 6” diameter.	At Storm Drain inlets and outlets and as required for erosion protection

6.3.10.4 Bollards

Above ground piping, valves, fire hydrants, and accessories adjacent to traffic areas shall be protected with minimum 6" diameter steel pipe guard post, minimum height of 42" above ground and painted yellow.

6.3.11 Oil/Water Separation

Work areas, equipment area, unloading areas, roads, and other areas subject to oil

spills, shall drain to an oil/water separator(s) system designed to prevent oil-contaminated runoff from leaving the site or contaminating the site. Other areas will be designed to drain out through the natural site drainage system. Treated water from the oil/water separator(s) shall be routed to the evaporation pond.

6.3.12 Unloading Areas

All oil, diesel, fuel and chemical tank loading/unloading areas shall be designed to provide for secondary containment of 110% of the largest single compartment of the relevant delivery truck. All diesel fuel oil and oil loading/unloading areas shall be designed and constructed in compliance with the EPA Spill Prevention, Control, and Countermeasure (SPCC) requirements.

6.4.12 Evaporation Ponds

Evaporation Pond layout shall be in accordance with the Site plan drawings included in Appendix C. Final design and sizing shall be shown in detail on Contractor's final plot plan. The ponds shall accommodate evaporation of wastewater inflows and storm water that has passed through the oil/water separator. The following design criteria shall apply:

1. Evaporation pond shall be designed to conform to UDEQ's "Design Requirements for Wastewater Collection, Treatment, and Disposal Systems (R317-3.1)."
2. Provide adequate storage for freeboard and fluctuations in water level due to wave action.
3. Provide storage capacity for solids deposits over a 30-year design life.
4. Provide three cells, each storing a minimum of 50% of the total maximum storage required.
5. Utilize the worst three consecutive years of historical precipitation data.
6. Evaporation rates shall be as published in the National Oceanic and Atmospheric Administration (NOAA) Technical Report 34, "Mean Monthly, Seasonal, and Annual Pan Evaporation for the United States."
7. Pond design shall allow for surplus storage of construction wastewater in addition to inflow from plant operations.

The ponds shall be double membrane lined with a minimum 60-mil high density polyethylene (HDPE) geomembrane for the primary and secondary liner.

A minimum 200-mil thick HDPE geonet shall be utilized for the leak detection layer between the two geomembrane layers. The leak detection layer shall drain to a drainage trench at the bottom of each cell that shall carry any leakage to a rock-filled collection sump at the end of each cell. Each sump shall contain a self-actuating pump with water level sensor to pump accumulated water back to the cell. Each sump pump system shall also have a run time logging device to monitor the volume of water transferred.

The primary liner shall be covered with a 12-inch thick layer of protective soil cover. Geotextile and riprap shall be placed above the primary liner on the pond side slopes to prevent wind and water erosion.

The entire pond shall be fenced with a minimum six-foot high chain link fence with three strands of barbed wire.

Maximum side slopes shall be 3:1. Slope stability and seismic concerns shall be evaluated per Utah DEP requirements. Ponds shall be provided with a gravel-surfaced access road around the top perimeter of the pond berms and the top of the intermediate berms. Top width of dikes shall be wide enough to accommodate roads and to provide sufficient access for monitoring, inspection, and maintenance.

Provide engineering support and documentation for all applicable permits including but not limited to Ground Water Discharge Permit, Dam Safety Permit, and Construction Stormwater General Permit. Permits will be obtained by the Owner. Work shall be in accordance with all applicable agencies including but not limited to the Utah DEP and Utah DWR. Work shall also be in accordance with any existing permits obtained by Owner.

Subgrade preparation and compaction shall be in accordance with sound geotechnical engineering practice and as recommended by the liner manufacturer.

Provide operation and maintenance manual for the evaporation ponds.

SECTION 7.0

STRUCTURAL AND ARCHITECTURAL SCOPE

This section covers the minimum scope and quality standards for the plant structural and architectural facilities.

7.1 MATERIALS

7.1.1 Steel

Design of structural and miscellaneous steel shall be in accordance with the 1989 American Institute of Steel Construction (AISC) Manual of Steel Construction – Allowable Stress Design.

Materials for structural steel and miscellaneous steel shall conform to the following requirements of the American Society for Testing and Materials:

1. Wide Flange (WF) Shapes and Tees cut from WF: ASTM A992, Grade 50
2. M shapes, S shapes, Hp (Bearing Piles), Channels, and Angles: ASTM A36
3. Structural Plates and Bars: ASTM A36

Metal decking shall comply with SDI "Design Manual for Floor Decks and Roof Decks."

Structural steel grating shall be welded and galvanized and shall conform to ASTM A569. Grating shall be banded at edges and openings with bars of the same size as the bearing bars. It is recommended that one size grating be used throughout the Project. Grating for exterior use shall be serrated.

Minimum stair tread width shall be uniform for full length of stairs. Rise and run of stairs shall be in accordance with local building codes, state requirements, the International Building Code (IBC), and OSHA requirements.

High strength bolts, nuts, and washers shall conform to ASTM A325. Galvanize bolts, nuts, and washers when connecting galvanized steel members.

Anchor bolts shall conform to ASTM F1554, Grade 36. Anchor bolt sleeves shall conform to ASTM A501.

Anchor bolts shall be used for all structural and building columns, all major equipment, and all vibrating equipment. Galvanize all anchor bolts exposed to the weather.

Steel pipe for handrail shall conform to ASTM A53, Type E or S, Grade B. Handrails for exterior use shall be galvanized.

All structural welding shall conform to the requirements of AWS D1.1.

Galvanizing, as specified herein, shall conform to the requirements of ASTM A123 or ASTM A153, as applicable.

7.1.2 Concrete

Design of structural concrete shall be in accordance with the American Concrete Institute (ACI) - "Building Code Requirements for Reinforced Concrete," ACI 318.

An independent testing laboratory shall be retained by the Contractor to perform acceptance sampling and testing of the concrete in the field. Sampling and Testing shall be in accordance with ACI 301 and applicable ASTM procedures. Make at least one strength test for each 100 cu yd, or fraction thereof, of each concrete mix placed in any single day. Determine the concrete slump for each strength test sample and whenever consistency of the concrete appears to vary. Determine air content of each strength test sample. Record the ambient temperature and the concrete temperature for each sample.

Minimum concrete strength classes for various structures shall be as follows:

Item	Minimum Ultimate Compressive Strength,(psi) (at 28 Days)
Subgrade leveling slab	2,000
Water retaining structures with aggressive exposures, i.e. cooling towers	5,000
All other construction	4,000

Reinforcing bars shall be deformed bars conforming to ASTM A615, Grade 60. Welded wire fabric shall conform to ASTM A185.

Cement shall be portland cement conforming to ASTM C150, Type I or Type II, or Type V, as necessary to comply with ACI 318 recommendations in Section 4.3 regarding sulfate exposures.

The minimum cement content for 4000 psi mixes shall be 564 lbs per cubic yard and the maximum water cement ratio shall be 0.45 unless noted otherwise. Maximum water cement ratio for 5000 psi mixes shall be 0.40. Concrete shall be homogeneous, readily placeable, uniformly workable and finishable, and shall be proportioned to conform to ACI 211.1. Mix proportions shall be selected in accordance with ACI 318.

Provide air entrainment for concrete permanently exposed to the weather. Total air content shall be based on ACI recommendations for the type and size of aggregate used in the concrete.

Aggregates for normal weight concrete shall conform to ASTM C33.

Provide a housekeeping pad under all pumps and heat exchangers. Pad shall extend a minimum of 6 inches above grade or slab, whichever is higher.

Provide a minimum of 1 inch of grout under all equipment, support structures, platform supports, pipe supports and other structural supports that are mounted on concrete foundations or concrete slabs. Apply grout in accordance with grout manufacturer's instructions.

All concrete trucks shall be rinsed out on site. Rinse material shall be properly disposed of as spoils in road base.

7.2 STRUCTURAL LOADING

7.2.1 Dead Loads

Dead loads shall include all vertical loads due to weight of permanent structural and nonstructural components, including permanent hung loads.

7.2.2 Live Loads

Live loads shall be in accordance with local codes, the 2003 International Building Code (IBC) and the provisions of the Utah Uniform Building Standard Act Rules (R156-56)

7.2.3 Wind Loads

Wind loads shall be in accordance with local codes, the 2003 International Building Code (IBC) and the provisions of the Utah Building Standards Act Rules (R156-56). Basic wind speed shall be 90 miles per hour.

7.2.4 Seismic Loads

Seismic loads shall be in accordance with local codes, the 2003 International Building Code (IBC) and the provisions of the Utah Building Standards Act Rules (R156-56). Seismic acceleration parameters shall be in accordance with the IBC as follows:

$$SDs = 0.74 \text{ g}$$

$$SD1 = 0.38 \text{ g}$$

The soil profile type shall be determined by the Contractor based on the results of a subsurface investigation, which shall be performed by the Contractor.

7.2.5 Thermal Loads

Buildings and structures shall be designed for forces and/or movements resulting from a change in temperature. Induced thermal loads (i.e., thermal loads induced by equipment operating temperatures) shall be considered in design of applicable structural elements.

7.2.6 Crane Loads

Crane loads shall be in accordance with the 1989 AISC Specification for Structural Steel Buildings – Allowable Stress Design (ASD) and Plastic Design and Code of Standard Practice for Steel Buildings and Bridges. Additional requirements for the turbine room crane are listed under Section 7.5, BUILDINGS / STRUCTURES.

7.2.7 Vehicle Loads

Design loading, for areas accessible to trucks, shall be (AASHTO) HS20-44.

Floors in buildings accessible to a forklift truck shall be designed for the forklift truck wheel loads.

7.2.8 Pipe and Equipment Anchor Loads

Supporting structures shall be adequate to resist all pipe and equipment anchor loading

under all design conditions, including seismic.

7.3 STRUCTURAL FOUNDATIONS

Type and depth of foundations required shall be as recommended by Contractor's Geotechnical Engineer based on the existing subsurface conditions and the geotechnical studies. The foundation system used shall be piling, drilled shaft, spread footing, or mat as recommended by the subsurface investigation report.

Foundations supporting rotating machinery shall be checked for resonant frequency and isolated from other foundations using expansion joints.

The combustion turbine generator foundations shall be isolated from surrounding building foundation mats and shall be designed such that no adverse dynamic response or settlement occurs. The foundation shall satisfy the settlement, deflection, and dynamic response criteria supplied by the equipment manufacturer.

The steam turbine generator foundation shall be designed for the following:

1. Static loading per Manufacturer's loading diagram.
2. Vertical impact load as specified by Manufacturer.
3. Area live load of 0.5 kip per square foot on all periphery beams at operating floor, 0.3 kip per square foot at intermediate floor level, and 0.3 kip per square foot on grating areas.
4. Torque, vacuum, horizontal impact, thermal and alignment loads per Manufacturer's load diagrams.
5. Deflection shall be limited to values specified by Manufacturer under loading conditions as specified.

Gas turbine foundations and steam turbine foundations shall include foundation imbeds for anchoring and aligning the gas turbine generator. Gas turbine foundations shall include fixators to facilitate alignments.

Electrical transformer foundations shall include fire walls as recommended by NFPA and the Owners Insurance.

Foundations for hydraulic equipment and oil-filled transformers shall include concrete slabs and curbs for containment of the largest spill plus fire water or precipitation from the 10-year recurrence interval.

7.4 ARCHITECTURAL

The architectural design of the buildings, sound attenuation, and all associated facilities shall seek to optimize functional, aesthetic, and economic considerations; and minimize the visual impact on the surrounding area. Safety and construction requirements shall be in accordance with the requirements of applicable state and local codes.

7.4.1 Siding/Panels

Exterior siding shall be steel wall panels. Insulation shall be installed between the exterior surface panel and the interior surface panel. In areas susceptible to damage, an interior liner panel shall be installed to 8' 0" above the walking surface.

Wall panels shall be designed to withstand the specified wind loading with practical/economical support girt spacing.

Exterior face of wall panels shall be finished with an epoxy prime coat and a urethane or polyurethane finish coat.

Interior liner panels shall be ceiling height and finished with siliconized polyester.

Owner to approve exterior and interior color selection.

7.4.2 Roofing

Roofing shall be designed to withstand specified snow loading and wind loading, including appropriate uplift. Roofing will be sloped metal.

Roofing shall be pitched not less than 1-¼ inch per foot and shall drain to a roof drain system. Pitch shall be governed by local codes and standards.

7.4.3 Interior Construction Materials

In general, architectural finishes for each area shall be per the following table:

Room Name	Floor	Wall	Ceiling
Steam Turbine Generator Building	mc	Mwlp	ex
Water Treatment	mc	Mwlp	ex

Equipment Building			
Electrical Equipment Room	mc	cmup/mwlp	ex
CEMS Shelters	mfg Std	mfg Std	mfg Std

Floor Finishes:

cmc – sealed, cast-in-place concrete coated with coating resistant to battery acid attack

mc - sealed, cast-in-place concrete

vct – reinforced vinyl composition tile

cft - unglazed ceramic tile

rcp – special raised composite panel floor

- Specialty coatings shall be applied in areas subject to acid or chemical spills

** Vinyl tile in Control Room shall be static dissipative type.

Wall Finishes:

gbp –painted gypsum board on metal studs

mwlp - metal wall liner panel at pre-engineered building exterior walls

cmup - filled, painted concrete masonry

cwt - glazed ceramic tile over masonry or gypsum board

Ceiling Finishes:

sap – lay-in grid, grid type, suspended acoustical panel (use moisture resistant type in lockers and toilet areas)

ex - exposed to structure

Except where concrete unit masonry partitions are required, ceiling high interior partitions shall be of metal stud and gypsum board construction. Where applicable, metal stud partitions shall be insulated to reduce sound transmission.

Hollow load bearing or non-load bearing lightweight concrete unit masonry or metal stud/gypsum board partitions shall be provided in stairwells and electrical rooms where required by Building Codes.

7.4.4 Platforms

Platforms, other than those within the scope of major equipment suppliers shall be provided by the EPC Contractor. All platforms shall be designed and supplied with handrail and toe-plate in accordance with OSHA standards. Ladders and stairs shall be in accordance with local Building Codes, the IBC, and OSHA standards. See Mechanical Scope, General Requirements, for the types of platforms required.

Provide self-closing, OSHA approved safety gates on all platform ladder openings. Chain type safety gates shall not be used.

Fasten all grating to platform steel using Saddle clips and Nelson studs with nuts.

7.4.5 Stairs

Stair construction shall be open riser stair treads. Stair treads and platforms shall have non-slip nosings.

Cross brace all stringers where the horizontal run exceeds 12 feet to provide lateral stability.

Fasten stair tread to stringer with a minimum of two 3/8-inch bolts.

7.4.6 Handrail

Railings shall be 1-1/2-inch standard weight steel pipe, and posts shall be 1-1/2-inch extra strong steel pipe, with welded joints, and ground smooth. The number of horizontal rails on handrail shall match the existing Block 1 handrail.

7.4.7 Windows, Window Walls, Entrance Doors, and Louvers

Windows and Window Walls – Window and window wall systems shall be anodized finished aluminum unitized framing systems with tinted, heat-treated, factory-fabricated, double pane insulating low "E" glass. Color of anodizing shall be selected to match the plant color system. Windows to areas which have possible explosive equipment failures shall be wire safety type.

1. Louvers – Louvers shall be drainable, fixed-blade, manual or gravity operating, weatherproof-type louvers, and shall include bird screens and be finished in a color to match adjacent wall panels.
2. Exterior Doors
 - A. Personnel Doors – Exterior doors shall be flush panel type insulated steel doors in pressed steel frames with weather stripping, weatherproof saddles, closures, and kick armor plates.
 - B. Coiling Steel Doors – Coiling steel doors shall be insulated standard type, motor operated, with manual chain-operated override, hood baffle, weather stripping, and bottom seal.
3. Interior Doors – With the exception of acoustical, fire rated, and coiling steel doors, all other interior doors shall be 1-3/4-inch thick, hollow metal flush panel-type in pressed steel frames. Vision panels shall be provided where appropriate. Interior doors to process areas shall have windows with wired safety glass.

7.4.8 Painting

In general, all exterior and interior surfaces, except items furnished in manufacturer's finish or finish coat, shall be painted, including:

1. All structural steel, piping, and miscellaneous steel (except surfaces to be enclosed by concrete).
2. Surfaces of all ferrous metal.
3. All gypsum board. Gypsum board shall be painted in a semi-gloss acrylic enamel latex coating system.
4. All concrete unit masonry. Concrete unit masonry shall be painted in an acrylic latex system, unless a special coating is specified.

Stainless steel and galvanized steel shall not be painted.

Protective Coatings

Component	Surface Prep.	Primer	Finish Coat
Interior Structural Steel Building Framing, including Framing for Hangers and Equipment	SSPC-SP6	Organic Zinc/epoxy, 3 to 4 mils DFT or Galvanized	Acrylic Polyurethane, 3 to 5 mils DFT or Galvanized
Misc. Steel, Interior or Exterior (handrail, stairs, ladders toeplate)	SSPC-SP6	Organic Zinc/epoxy, 3 to 4 mils DFT or Galvanized	Acrylic Polyurethane, 3 to 5 mils DFT or Galvanized
Exterior Structural Supports & Framing for Equipment	SSPC-SP6	Organic Zinc/epoxy, 3 to 4 mils DFT or Galvanized	Acrylic Polyurethane, 3 to 5 mils or Galvanized
Platform, Stair Grating, Handrail, and Ladders Interior and Exterior	Per the American Hot Dip Galvanizers Assoc. recommendations	Hot Dipped Galvanized	
Interior Above Grade Uninsulated Piping (Not requiring color coding)	SSPC-SP6	High Build Epoxy Primer or Galvanized	None.
Interior Above Grade Uninsulated Piping	SSPC-SP6	High Build Epoxy Primer	None

(Requiring color coding)		or Galvanized	
Exterior Above Grade Uninsulated Piping	SSPC-SP6	Inorganic Zinc Rich Primer	Polyurethane, 3 to 5 mills
Exterior and Interior Insulated Piping	None	None	None.
Equipment, Motors, Valves, Instruments, and other manufactured components	Manufacturer's Standard	Manufacturer's Standard	Manufacturer's Standard
Stainless Steel, Galvanized, or Nonferrous pipe or Materials	None	None	None
Stacks and other hot surfaces	SSPC-SP6	Inorganic Zinc rich ethyl silicate, 2 to 3 mils, DFT	Hi-temp silicon, 3 to 5 mils

7.4.8.1 Surface Preparation

The exterior surface of structural and miscellaneous steel, and tanks shall be abrasive blasted in accordance with the Society for Protective Coatings, SSPC-SP6, Gray Commercial Blast, or SSPC-SP10, Near White Blast for submerged items.

Tank interiors to be lined shall receive an abrasive blast in accordance with SSPC-SP5, White Blast, with a 3.0 mils maximum anchor pattern.

Small miscellaneous field fabrications shall be given not less than SSPC-SP3, Power Tool Cleaning.

All masonry surfaces to be coated shall receive a light brush-off blast or an acid etch prior to coating.

Piping shall be field-cleaned to a minimum of SSPC-SP3, Power Tool Cleaning.

7.4.8.2 Prime Protective Coating for Steel

All structural and miscellaneous steel shall be primed within 8 hours after the surface preparation is completed to a full 2.5 mils. The primer shall be as specified in the Protective Coatings Table, this Section. Open web joists may be primed with a red iron oxide primer.

7.4.8.3 Finish Coating

Structural and miscellaneous steel shall be finish coated as specified in the Protective Coatings Table, this Section.

Above grade piping designated to be painted, shall be color coded to coordinate piping service. Provide a color code chart to Owner for approval indicating piping color for each piping system included in the Project.

Before painter's finish work is begun, the surfaces to be painted shall be carefully inspected to assure that they are in proper condition to receive the finish coating. Surfaces, which are in poor condition, so that a proper finish cannot be produced, shall receive such special treatment or additional coats as necessary to produce a smooth, durable, satisfactory finish. Contractor shall supply color samples to Owner for approval.

7.5 BUILDINGS/STRUCTURES

7.5.1 Minimum Requirements

Drawings showing floor plans, equipment arrangements and other building and architectural features shall be submitted by the Contractor for Owner's review, comments and approval. Building framing may be Pre-Engineered or designed of standard rolled shapes. The use of shipping containers retrofitted for packaging of systems shall not be allowed.

Include lifting devices such as cranes, hoists, trolleys, and monorails in all buildings and structures at locations above all equipment weighing more than 200 lbs. Capacity of the lifting device shall be at least 15 percent above the maximum load to be lifted.

Coordinate locations with the equipment layouts.

Design all building roofs, platforms, and structures for a minimum collateral load of 15 psf, in addition to the Code required and specified live loads. Increase the minimum collateral load in routing corridors for piping, electrical conduit, and cable tray, and determine the design collateral load by consideration of actual weights and by calculations.

Buildings shall be provided as follows:

Building	Min number of external doors / windows	Minimum Size	Special Notes
Steam Turbine Generator Building	Exit doors in accordance with Building Code. Minimum of two roll-up doors.	Per the Site Plan	One of the roll-up doors shall be sized to allow removal of the largest piece of equipment.
Water Treatment Equipment Building	2 roll-up, 2 doors, no windows	Per the Site Plan	
CEMS Shelters	1 door	8-foot x 10-foot (if 1 per GTG) or 10-foot x 12-foot (if 1 per 2 GTGs) Minimum of 1 per 2 GTGs	
Boiler Feed Pumps Building	Per Building Code requirements.	As required for access of equipment	Include monorail for maintenance of pumps and motors.
Other Buildings	Per Building Code requirements.	As required for access of equipment	

7.5.2 Steam Turbine Generator Building

Column Bases shall be designed as pinned.

The turbine room roof design shall utilize horizontal bracing.

Floor and roof live loads shall be as follows:

- | | |
|---------------------------------------|---------------------------|
| 1. Turbine room roof | 30 psf |
| 2. Operating floor, turbine room area | 500 psf |
| 3. Operating floor, other areas | 250 psf |
| 4. Ground floor | 300 psf plus HS20 loading |

Building footprint shall be adequately sized to allow laydown of all turbine generator components during maintenance or refurbishment.

7.5.3 Other Structures

Contractor shall provide sun shade covers for all CO₂ and bulk gas storage systems.

Provide a minimum of 20-foot wide shed roof structure on the north side of the maintenance shop to provide covering for equipment and maintenance materials. Shed roof shall extend the length of the maintenance shop building.

7.5.4 HRSG Equipment Enclosure

Provide steel frame equipment enclosure with weather-tight metal siding and roof deck at the top of the two HRSG Units. Include doors with hardware, ventilation, and interior lighting.

7.5.5 Turbine Room Crane

The Turbine Room Crane shall be capable of handling the heaviest piece of disassembly of the steam turbine. Determine the required crane capacity by consideration of the maximum weight to be lifted during overhaul of the actual equipment furnished. Estimated crane capacities are as follows:

75 - ton minimum capacity main hook

25 - ton minimum auxiliary hook

Operation shall be by remote radio control and by control pendant suspended from trolley. Include a platform with stair or ladder to provide access to the crane bridge service platform from the Turbine Operating Floor.

SECTION 8.0

ELECTRICAL SCOPE

8.1 GENERAL REQUIREMENTS

This section covers the minimum scope and quality standards for the major electrical equipment, systems, and interfaces with other plant systems and facilities and with off-Site facilities. Contractor shall provide all material and labor for the engineering, design, procurement, installation, construction, startup, inspection, and testing of all electrical systems specified herein and necessary for a complete, functional power generating facility, and in conformance with generally accepted utility practices for generating facilities.

The conceptual design is shown on one line diagram SKE-1 that is included in Appendix E. Contractor shall develop a detailed plant design based on Owner's conceptual design. Alternative designs may be acceptable if they meet the functional requirements of this specification. Any changes in plant arrangement or design must be approved by the Owner. Arrangement and design of the auxiliary power system equipment shall provide for unobstructed vertical clearance on the access road between units for bringing in cranes and other heavy equipment for maintenance.

The design and specification of all work shall be in accordance with all applicable laws and regulations of the Federal government and the State of Utah, and applicable local codes and ordinances. A listing of the codes and industry standards to be used in design and construction is found in Section 3.0. All equipment furnished under these specifications shall conform to applicable standards of IEEE, NEMA and ANSI. All materials and devices shall be in accordance with the applicable requirement of the Federal "Occupational Safety and Health Standards". The latest editions of the referenced codes and standards shall apply. Equipment ratings and capacities are

generally referenced to 40° C maximum ambient and less than 3300 feet. Contractor shall revise ratings accordingly for equipment and materials where required for Project maximum ambient conditions and elevation.

Other recognized standards may be utilized when required in Contractor's opinion and when not in conflict with the standards listed in Section 3.0. Contractor shall notify and obtain Owner approval prior to any changes.

8.1.1 Plant System Studies

Contractor shall perform a set of system studies to demonstrate the adequacy of the proposed electrical system design, including AC and DC distribution systems, by performing the following studies as a minimum. The design and construction of the electrical systems shall reflect the findings and conclusions of these studies. Prior to starting studies, provide Owner with cases to be analyzed. Owner will identify other cases if required to meet the criteria established in the following. These system studies shall be subject to review and comment by Owner.

1. Load flow and voltage regulation

A series of studies shall be undertaken over a range of operating conditions, including pre-synchronizing, post-synchronizing, variation in grid voltage, auxiliary transformer failure, etc., to demonstrate that the plant electrical equipment operates within its manufacturer's rating and the voltage at all buses is maintained in the required range. For the studies, cable impedance shall be included and transformer and generator impedance shall include the maximum positive tolerances.

Transformer impedance shall be determined to optimize the through-fault withstand current of the transformer and the interrupting duty of the switchgear and switchyard breakers and to ensure that the voltage will not fall below allowable limits when the largest motor will be started.

The studies shall include motor starting studies to show that, when starting any motor, the distribution voltage at all levels does not fall below 90% of motor nameplate rating except for motors designed for lower terminal voltage. This requirement shall apply for all the contingencies given above and include motors of the largest starting current at each voltage level. Motors subject to

the low starting voltage will be rated for 80% starting voltage.

Evaluate generator step-up transformer reactive power flow study to verify that transformer does not reduce generator reactive power flow through all operating conditions. Reactive power flow shall be evaluated in accordance with IEEE C57.116 to meet a power factor of 95% lagging and 95% leading for each unit at the 345 kV side of the generator step-up transformer.

System design shall provide for transmission voltage deviation of plus or minus 5% and short term (one minute or less) voltage excursions of plus 10% to minus 10%. During normal operation system bus voltage shall be within plus or minus 5% of nominal voltage. Auxiliary equipment shall be designed for continuous operation for a plus or minus 10% voltage variation.

2. Fault level

Studies shall be undertaken to ensure that the prospective fault current is within the rating of the switchgear and cables. For these studies: cable impedance shall be ignored, full motor contribution shall be included, and transformer impedance shall be at the maximum negative tolerance.

3. DC System Studies

A load profile shall be developed for all DC loads to size the batteries and chargers, and to verify minimum voltages are maintained as specified and required by equipment vendors.

4. Grounding Studies

Perform grounding system studies using a minimum of a 2 layer model to limit touch and step potentials to safe values as specified. The calculation of the ground resistance shall include the switchyard area and plant. The grounding system shall be designed to provide personnel safety and to provide protection to electrical equipment. The grounding system study shall be in accordance with the requirements of IEEE 80, 81, 81.2, 142, 665 and 1050, NESC and the NEC. Soil resistivity shall be measured as described in IEEE 80.

5. Arc-Flash Study

Perform arc-flash study for medium voltage switchgear, contactors, 480 volt switchgear, 480 volt motor control centers, and 480 volt distribution panels. Study shall be performed based on IEEE 1584 – Guide for Performing Arc-Flash Hazard Calculations. Arc-flash study shall calculate incident energy and boundary areas where no special clothing or personal protective equipment is required. Arc-resistant equipment shall be furnished for medium voltage busses. Incident energy shall be limited to a maximum of 40 cal/sq-cm for all 4160 and 480 volt busses.

6. Protective Relay Coordination Study

A protective relay coordination study and relay setting report shall be prepared. This study will serve as the basis for relay protection for the plant electrical distribution systems. Relay settings are required for all protective relays furnished by Contractor. Recommended settings for combustion and steam turbine relays will be provided by equipment supplier. Contractor shall provide settings for relays requiring system information. Contractor shall request any information from Owner to provide relay settings. Contractor shall provide a hardbound report including settings, calculations, system data, one lines, and coordination curves. In addition a CD shall be furnished including all documents in the report, relay setting files, relay communication software, instruction manuals, and application manuals where applicable. Contractor shall coordinate with the local utility company to implement any special protection or system requirements.

8.1.2 Interface Requirements

8.1.2.1 Utility System Interface

The interconnection of the plant into the Utility system will be through a 345 kV switchyard extension. The switchyard will be supplied by Others under a separate Contract. The interfaces as described in the following will refer to the Owner's switchyard. The switchyard interface will be at the following points:

1. Generator step up transformer dead end structure (switchyard Contractor will install overhead line to dead end structure and make drops to transformer).
2. Switchyard relaying and metering interface terminal box; SCADA communications junction box, switchyard station service power marshaling

box.

3. Grounding consisting of two connections per step up transformer plus one connection per duct bank.

A generator fault on a combustion turbine shall trip only its associated generator excitation and low side generator circuit breaker. This scheme should allow the auxiliary loads to continue receiving the power supply from the switchyard through the corresponding station auxiliary transformer. A fault on a step-up transformer shall trip its high side circuit breakers and associated generator breaker. A fault on the steam turbine generator shall trip its associated high voltage breakers.

Contractor shall coordinate with Owner's switchyard contractor for routing of circuits to the switchyard control building. In addition to the required raceways, Contractor shall provide two spare 4" conduits from administration building to Owner's switchyard. The Contractor shall interface with Utility company and Owner's switchyard contractor for interconnection of the power plant at least but not limited to the following technical areas:

1. Basic System Design
2. Protective Relays of the generation system.
3. Engineering Studies
4. Metering
5. Telemetry
6. Generator synchronizing
7. Reactive Power Requirements
8. RTU Dispatch Control
9. Backup power supply
10. Dead end structure line termination

The Contractor shall include interfaces to an RTU (remote terminal unit) located in the switchyard control building. The interface shall include as a minimum the following isolated metering, control, and status points per unit:

1. Gross megawatts
2. Net megawatts
3. Auxiliary megawatts
4. Station net megawatts

5. Gross megavars
6. Net megavars
7. Auxiliary megavars
8. Generator voltage
9. Upper operating limit
10. Lower operating limit
11. AGC control status
12. Power system stabilizer status
13. Voltage regulator status

Final point list shall be developed during Contract execution, and shall include additional points typical of this type of installation.

Furnish and install plant side revenue metering system consisting of Maxsys 2510 revenue meters for each generator and auxiliary transformer, current transformers, and potential transformers for combustion turbine generator gross (low side for each unit), combustion turbine auxiliary load (each unit) and steam turbine gross (low side). Meters shall be furnished with 5759 firmware, peer to peer networking capability, bi-directional metering capability, DNP 3.0 communications protocol, 4 KYZ outputs, and 4 analog outputs. Meters shall be connected to allow internal calculation of unit and net station power. Meters shall be connected to dedicated revenue quality current and potential transformers. Provisions shall be included to accumulate auxiliary power when the CT units are off line in separate registers or other methodology as approved by Owner. Owner will supply meter catalog number. Hardwired analog, pulse, and communication outputs shall be made to switchyard RTU. Metering to have remote dial up capability.

Provide rack space, 48V 150A-H battery and charger system for the Owner provided DMXplore and Channel bank communications equipment. Furnish conduits and fiber cable between the new 345 kV switchyard and the communications equipment.

Owner will ultimately enter into a power supply agreement in accordance with the Large Generation Interconnection Agreement (LGIA) and associated documents included in Appendix H. Contractor shall include all technical and operational requirements within the plant to design to meet the requirements of the LGIA and associated documents.

8.1.2.2 Plant Synchronizing and Switching Scheme Interface

Contractor shall design a synchronizing scheme in coordination with the turbine supplier. Combustion turbines will be synchronized across low side generator breakers and the steam turbine will be synchronized across the switchyard breakers. Design shall be based on a single high side breaker connected to a collector bus.

As required to ensure proper synchronization operation, phase matching potential transformers shall be provided to compensate for any phase angle and potential differences (caused by step-up transformer phase-shift) on the derived voltage sources from the switchyard and generator systems. Potential selection relays and selection logic shall be included as part of the synchronizing scheme.

8.1.3 Auxiliary Power Supply Equipment

The auxiliary power supply equipment includes the unit auxiliary transformers, 4160-volt switchgear, 4160-volt motor control centers, 480-volt secondary unit substations, 480-volt motor control centers, 480/277-volt distribution panelboards, and 208/120-volt power panels. All 4160 volt switchgear and 4160 volt motor control centers shall be arc-resistant. The auxiliary power equipment shall distribute electrical power to the plant auxiliary equipment. Electrical equipment with the exception of transformers shall be installed in rooms with a controlled environment including redundant air conditioning, except as approved by the Owner. Each class of primary distribution equipment (4160-volt switchgear, 4160-volt MCC, 480-volt switchgear, 480-volt MCC's) shall be of the same type and manufacture (i.e. all 4160-volt switchgear shall be of the same type and manufacture, but not necessarily the same manufacture as the 480-volt switchgear).

Critical loads for each block will be configured in such a manner that critical loads can be easily and quickly isolated from the normal source and transferred to the backup source (emergency diesel generator). Included in the critical loads are the loads to keep the combustion turbines in a ready to start condition, steam turbine critical loads, DC system, HVAC, communications and other loads as selected by Owner. Loads shall be selected up to the capacity limit of the emergency diesel. In addition, Owner plans to make provision for a "maintenance tie" between the existing Unit 1 4160 volt auxiliary electric system and the new 4160 volt system. Contractor shall include, as part of the new 4160 volt switchgear equipment, a 4160 volt breaker and interconnecting power circuit for interconnecting with the existing Unit 1 4160 volt switchgear. . Contractor shall

furnish all required protection and control equipment (including synchronism check) needed for such interconnection. Owner may also consider utilization of the distribution system from which construction power is obtained as a source of backup power, and Contractor shall propose this as an alternate.

Each 4160 and 480 volt bus shall be provided with metering functions to include, 3-phase bus voltage, 3-phase current, kW, kVAR, kWh (meter functions may be provided through protective relay data to DCS). Summary metering shall be configured to provide total kW, kVAR, kWh for the station and the auxiliary power system. The station service power shall be supplied from the utility system during plant startup, shut down, and maintenance periods. Power shall be supplied from the generated power during normal operation. Primary control for medium and low voltage switchgear, mains, ties, and feeders shall be from the distributed control system. Backup control shall be provided near the switchgear to allow buses to be energized if the DCS is out of service. DCS shall display feeder and bus metering information in addition to switchyard voltage.

The quantity and size of 480 volt panel boards shall be selected such that the capacity is adequate for total running load under all operating conditions, plus a 20% design allowance, plus 10% allowance for future use. The continuous current ratings and interrupting ratings of the feeder breakers shall be based on the available fault current and the characteristics of the connected load. Each distribution panel board shall include the feeder breakers required to supply the connected load, plus two three-pole and two single-pole feeder breakers for future use.

Welding receptacles shall be provided for portable 480 volt, 3-phase welding equipment. Sixteen receptacles will be placed in strategic locations as directed by the Owner.

All 208 volt loads and all single-phase 120 volt loads shall be supplied from the 208/120-volt power panels. The continuous current rating of the main bus and the 480-208/120-volt transformer shall be as required plus a 20 percent design allowance. The continuous current ratings and interrupting ratings of the feeder breakers shall be based on the available fault current and the characteristics of the connected load. Distribution transformers shall be dry type, U.L. listed, class H insulation (based on a 115 degrees C rise) with 4 – 2½ % FCBN and 2 – 2 ½ % FCAN taps in primary winding with suitable enclosure. Motor space heaters, equipment space heaters, equipment lights and receptacles and equipment miscellaneous power feeds shall be from power panels.

Each power panel shall include the feeder breakers required to supply the connected load, plus 6 single-pole feeder breakers for future use.

8.1.4 Classification of Hazardous Areas

Areas where flammable and combustible liquids and gases are handled and stored shall be classified for the purpose of determining the minimum criteria for design and installation of electrical equipment to minimize the possibility of ignition. The criteria for determining the appropriate classification are specified in Article 500 of the National Electric Code (NFPA/ANSI C1). The application of these criteria to specific areas at generating stations is provided in Article 127 of the National Electrical Safety Code (ANSI C2) and applicable NFPA standards.

8.1.5 Lighting

A lighting system shall be furnished for all structures and new equipment. The lighting system shall provide personnel with illumination for plant operation under normal conditions, means of egress under emergency conditions, and emergency lighting to perform manual operations during a power outage of the normal power source. Provide aviation lighting system for stacks, if required. The power supply for the lighting system shall be from 120/208 or 277/480 volt, 3-phase, 4-wire lighting panelboards. Emergency lighting shall be powered from a 120 volt AC normal source with local battery backup.

The lighting system shall be designed in accordance with the Illuminating Engineering Society (IES) to provide illumination levels recommended by the following standards and organizations:

1. ANSI IIES RP-7, 1979, Industrial Lighting.
2. ANSI IIES RP-8, 1977, Roadway Lighting.
3. Federal Aviation Administration (FAA).
4. Occupational Safety and Health Act (OSHA).

In addition to the above, the lighting design shall meet all local codes and regulations. Lighting sources and fixture selections shall be based on the applicability of the luminaries for the area under consideration.

Four types of lamps shall be used for the light sources in the lighting system including fluorescent, high-pressure sodium, metal halide, and incandescent. Generally,

fluorescent lamps shall be used in indoor, low-bay enclosed areas; high-pressure sodium lamps shall be used outdoors, metal halide in high-bay enclosed areas, and incandescent lamps shall be used for emergency lighting. Exterior lighting shall include all roadways, HRSG platforms, combustion turbine platforms, CEMS equipment platform areas, and evaporation pond sump. Lighting levels shall be designed to at least the following minimum foot-candle levels:

Platforms, stairs, & walkways	10
Maintenance areas	50
Toilets and locker rooms	40
Warehouses/mechanical rooms	20-30
Water treatment	30
General outside areas	1
Roadway and parking areas	1
Electrical rooms	50

In general outside areas shall be controlled by photocell. Outside areas such as HRSG platforms shall have auto/manual stations to selectively turn-off lights when plant is not operating.

8.1.6 Telephone and Data Systems

Contractor shall expand the existing telephone/data network to include the Block 2 equipment. As a minimum voice/data lines shall be installed to the areas tabulated below. The telephone / data system design including all equipment shall be approved by the Owner. Provide dedicated raceway system from the control room building to the plant terminal point for telephone cable.

Contractor shall include a raceway system, wiring, jacks, and switches as required for the telephone and communications system indicated below. Listing is per building when multiple buildings are included:

Facility	Voice	Data	Analog
Admin Building	4	4	2
Boiler Feed Pump Enclosure	1	1	1
Chemical Treatment Building	1	1	1
Power Distribution Building	1	1	2

CEMS	1 Each	1 Each	1 Each
CT Electrical building	1 Each	1 Each	2 Each
ST& CT Excitation Building	1	1	2
Gas Regulating station		1 (fiber)	2

Final locations will be determined by Owner during detailed design.

Provide data ports with interconnecting Category 6 wiring for 100 mbps plant network at locations near the phone outlets. Data ports in other buildings remote from the Control/Administration building will be connected through fiber optic cable unless otherwise approved.

8.1.7 Construction Power

Contractor shall contact local utility and make arrangements for construction power services. Contractor shall pay all fees and operating costs associated with the installation, operation, and maintenance of the service including removal at project completion. Construction power shall be available through the duration of the project up to commercial operation unless approved by Owner. Owner will furnish power for commissioning and startup through back-feed of the auxiliary transformers. This power source will not be available for construction.

8.1.8 Freeze Protection

A freeze protection system shall be provided for piping, instrument impulse lines (integral tubing bundles), gauges, pressure switches, and other devices subject to freezing. See Division 5 and 9 for additional requirements. All transmitters, remote gauges and switches located outdoors shall be located in a heated instrument enclosure complete with a thermostat and space heater which will automatically turn on when the ambient temperature falls below 40 F. The enclosures shall be designed such that the heater cable circuit for the integral tubing bundle connecting the instrument to the process is terminated inside the enclosure.

On pipes that operate below 300°F, parallel circuit type heating cable shall be directly applied to the pipe. These heating cable circuits can be assembled and installed in the field using the appropriate connection kits.

For pipes which operate at 300°F and above, parallel circuit-type heating cable shall be sandwiched between layers of insulation or heat tracing of suitable temperature rating shall be used. These heating cable circuits can be assembled and installed in the field using appropriate connector kits.

Power distribution panelboards, each fed from 480-120/208 volt transformers shall furnish power to the freeze protection circuits. Power to the freeze protection circuits shall be controlled by ambient thermostats through a central control panel which shall provide control and alarm/monitoring functions for the freeze protection system. In addition, thermostats that sense actual pipe temperature may be required to prevent overheating of critical process or chemical piping. Remote alarms for the overall system and local monitoring of each freeze protection circuit shall be provided.

8.1.9 Cathodic Protection System

Cathodic protection and other corrosion control measures shall be provided to protect metal tank bottom and underground piping and shall be designed and installed according to soil survey results. A study shall be prepared by a corrosion control specialist (member of NACE) to provide recommendations as to the requirements for, and methods of, preventing corrosion of metallic elements due to galvanic action. This study shall be submitted for review by the Owner. The study shall include a conceptual design, including comparison of active versus passive corrosion control methods, and a bill of material for implementation of any recommended corrosion control system.

8.1.10 Lightning Protection

Lightning protection system shall be provided for building structures, transformers, the GT packages (including HRSG and stacks (regardless of stack thickness), the air-cooled condenser, and tanks.

Lightning protection for the building structures shall consist of air terminals installed at the highest points. The air terminals shall be connected together with copper cable and connected to the plant ground grid with copper down conductors. Protection system will be certified with a Master Label.

8.2 ELECTRICAL PROTECTIVE SYSTEMS

This Contract shall furnish and install an coordinated protective relay system to detect faults and trip the appropriate equipment. Owner will review and approve all protective

relay equipment, logic, nomenclature and settings to verify consistency with the specifications and Owner's standards. Contractor will coordinate with switchyard supplier to ensure a proper interface.

In general protective relays are to be based on the Schweitzer relay products unless specifically approved by Owner. Any grouping of relays shall be provided with an SEL-2030 for remote modem access. Contractor to include communication lines to allow remote dial up capability. All protective relays shall be time synchronized using a station IRIG-B time signal. All relay currents, potentials, and trips shall be wired through test switches. When required relay outputs shall trip ElectroSwitch type LOR lockout relays with a minimum of 10 decks. Owner shall provide assignment of relay output contacts. All current, potential, and lockout trip contacts shall be wired through clear cover test switches.

8.2.1 Generator Protective Relays

The generator protection system shall be based on redundant SEL-300G multifunction relays. Relays shall include the following protective functions: 21 backup impedance; 24 volts/hertz; 32 Multi-step reverse power; 27TN/59N 100% stator ground fault; 46 Phase unbalance; 50/27 inadvertent energization; 50BF breaker failure (combustion turbines); 59 over voltage elements; 59N bus ground fault; 60 loss of potential detection; 78 out-of-step protection; 87 differential protection. In addition to protective functions relay shall have extensive metering capability, oscillography, self-diagnostics, and communication capability.

Each SEL-300G will be provided a lockout relay for turbine tripping and a lockout relay for generator tripping. Tripping, blocking, and initiate logic shall be consistent with Owner's operating requirements and coordinated with the switchyard protection.

8.2.2 Generator Step-up Transformer Relays

The primary protection shall be an SEL-387E that only includes the transformer windings in the protective zone. Relay shall trip dedicated lockout relay. Backup relaying shall be dual SEL-387's connected in unit differential configuration. Backup relays shall trip dedicated lockout relays. The protection zone shall include the 345 kV breaker, generator and auxiliary transformer tap (steam turbine does not have auxiliary transformer.) Dual sudden pressure contacts and dual neutral current transformers shall

be provided as inputs to the protective relays.

8.2.3 Unit Auxiliary Transformer Relays

Protection for auxiliary transformers shall include an SEL-387E with a protective zone including the auxiliary transformer and switchgear main breaker. Provide lockout relay for status, blocking, and tripping functions.

8.2.4 Medium Voltage Switchgear and Motor Controllers

Provide SEL-351A multifunction protective relays for mains, ties, and non-motor feeder breakers. SEL-701 shall be used for protection for motor feeders. Relays will be configured to detect faults or abnormal operating conditions and trip appropriate breaker or alarm operator and coordinated with other protective devices. Any trip operations will include lockout functions to block closing of breakers without operator intervention.

8.3 SWITCHYARD

Others will design and install the switchyard and equipment from the high side of the step-up transformers to the switchyard except as specified. Contractor shall coordinate design between Contractor and Switchyard Contractor to determine placement of dead end structures, transformers, protective relay settings, interface junction box, RTU communication connections, power feeds and associated details.

This Contract shall provide two separate 480 volt feeds (200A each) to the substation to provide redundant AC auxiliary power sources for the substation. Contractor shall also provide two, 125 VDC, 100A each and one 1 kVA 120 volt UPS supply to the switchyard control building interface cabinet by the Switchyard Contractor.

8.3.1 Deadend Structures

EPC Contractor shall provide one dead-end structure for each GSU. Dead end structure shall have a conductor height of 45 feet, a shield wire height of 65 feet, mast height of 20 feet, phase spacing of 20 feet and a line angle from 0 to 20 degrees. Design conditions shall be NESC heavy loading. The structure shall be designed using the ultimate stress method. The following are the maximum loads:

Conductor Loading - 3000 lb per conductor

Shield Wire Loading – 2500 lb per wire

EPC Contractor shall provide engineering, procurement, and installation of GSU dead end structures including all supporting systems. These systems include but are not limited to all low and high voltage cable, conductor, and connectors; raceway; foundations; grounding; and monitoring, controls, and protection. All high-voltage systems shall be coordinated with plant and switchyard design and installation. Owner will approve final design and arrangement of dead end structure.

8.4 GENERATOR STEPUP TRANSFORMERS

This section covers power transformer equipment, material, and accessories. The power transformers furnished shall have all standard and normally supplied accessories ready for installation, connection, and immediate service. The following requirements are to be used in conjunction with the applicable sections of the Owner's specifications for transformers 'Material Specification ZS 001 dated October 2007, Substation Equipment – Power Transformer All Ratings' included in Appendix F.

Transformers shall be generator unit step-up transformers (GSU), shall be 345 kV nominal secondary, and generator rated voltage nominal primary, and shall be rated a minimum 5% over generator capability throughout the full ambient operating range with a temperature rise limited to 65°C. The method of cooling shall be ONAN/ONAF/ONAF. Step up transformers for the combustion turbines shall be designed for a minimum guaranteed efficiency of 99.7% and the steam turbine 99.75% at the top ONAF rating.

On initial selection of transformer supplier, Contractor shall provide Owner with the guaranteed load and no load losses for the step-up transformers at the top ONAF rating. In the event the tested losses are greater than the guaranteed losses, Contractor shall reduce the contract price by the sum of \$5,780/ kW for no load losses above the guaranteed value and \$2,170 / kW for the load losses above the guaranteed value. The no load and load loss evaluation will be performed independently of each other. In the event losses are less than the guarantee value, the Contract Price shall be increased by the sum of \$2,890 / kW for no load loss differential plus \$1,085 / kW for the load loss differential.

Transformer high voltage winding BIL shall be a minimum of 1050 kV with 350 kV neutral. High voltage bushing shall have minimum BIL of 1175 kV. Low voltage winding

shall have a minimum BIL of 150 kV. Transformer size, impedance and high side tap shall be selected to allow full range of generator reactive capability at the system nominal voltage. Transformer impedance shall be approximately 6% on an ONAN base and 10% at maximum rating. In addition, transformer impedance shall be selected to limit fault current below generator breaker interrupting level, and allow starting of largest plant motor without exceeding NEMA starting criteria.

All equipment shall conform to the applicable standards of ANSI, NEMA, and IEEE and shall be in accordance with the applicable requirements of OSHA standards. The latest published edition of referenced standards shall apply.

The power transformers shall be designed, fabricated, and tested in accordance with ANSI C57 series, C62, NEMA TR 1, and these Specifications.

Transformers shall be provided with oil containment and drainage to the plant oil water separator. Drain lines shall be provided with normally closed manual drain valves.

Transformers shall be provided as a minimum with the following accessories and capabilities:

1. 4 (four) full capacity 2 1/2% taps, 2 (two) above and 2 (two) below nominal voltage rating for manual "no-load" operation.
2. Standard angular displacement of voltages to match existing Unit 1 GSU transformers.
3. Sound level not to exceed 85 dBA at 3 feet at top ONAF rating (or less if required to meet project sound limitations).
4. Continuous over excitation capability of 110% at full load and 125% for 30 seconds.
5. Manholes located in cover.
6. Lockable tap changer handle accessible from ground level.
7. Short circuit capability with only transformer impedance limiting fault current.
8. Accessible core ground bushing and well for core ground.
9. Detachable radiators with lifting eyes and upper and lower isolation valves.
10. Upper and lower filter connections with sample valves.
11. Qualitrol temperature monitor with a minimum of 8 output contacts, diagnostic alarm, communications capability, and analog outputs.

12. Oil temperature and level gauges.
13. Conservator or sealed tank with inert-gas pressure oil preservation system.
14. Pressure relief device with a semaphore visible from ground level.
15. NEMA 3R control cabinet with latchable doors.
16. Adequate number of current transformers with relay accuracy of C800 and metering accuracy of 0.3B1.8 (or as required by interconnect standards) for plant metering and relaying including any relaying interface with substation. Current transformers shall have a minimum thermal rating factor of 2.0. A minimum of three current transformers on high side with at least one with metering accuracy and two on the low side.
17. Dual neutral current transformers.
18. Station Class surge arresters (internal surge protection not acceptable) with an MCOV of not less than 110% of line to ground voltage.
19. Discharge counters.
20. Sudden pressure relay device with dual outputs.
21. Fall protection device mounting provisions.
22. Serveron on-line gas analysis monitor with communications capability to the plant DCS, alarm and configurable analog outputs.
23. Copper windings with EHV-Weidmann insulation and materials suitable for 120° C continuous operation.
24. Local annunciator with common alarm or adequate alarms in DCS to quickly identify alarm source.
25. Maximum core flux density of 1.7 Tesla at no load and 100% rated tap voltage.
26. One spare high and low voltage bushing.
27. High temperature gasket material (Viton).

Factory Tests:

1. Notify Owner not less than two weeks prior to the starting date of the factory tests to permit observers to be present during the factory tests.
2. Procedures for factory tests shall conform to ANSI C57.12.90, unless otherwise specified. Except where a specific test method is specified, the factory test report shall state the test method used. Perform the following factory tests on each transformer unless otherwise stated:
 - A. Winding ratio on rated voltage connections and on all tap positions.

- B. Winding polarity and phase relation on the rated voltage connections.
 - C. Excitation loss at 100% and 110% of rated voltages on the rated voltage connections.
 - D. Excitation current at rated voltages, and at 110% rated voltages, on the rated voltage connections.
 - E. Impedance and load loss at the maximum 65°C rise rating.
 - F. Temperature rise at the maximum 65°C rise rating for the transformer supplied under this contract. Records of temperature tests performed on duplicate or essentially transformers will not be acceptable.
 - G. Temperature indicator accuracy test.
 - H. Applied potential test.
 - I. Induced potential test with the transformer connected at rated voltage, with the transformer's own bushings in place, accompanied by partial discharge monitoring (to conform to ANSI C57.12.90) with transformers own bushings in place.
 - J. Switching surge tests on the high-voltage winding, with the transformer's own bushings in place.
 - K. Test all control wiring for continuity, grounds, and correct connections; and test operation of all relays, indicators, switches, lights, and interlocks.
 - L. Resistance measurements of all windings on the rated voltage connection and all load tap connections. Test results shall be reported in ohms at 75°C
 - M. Doble insulation power factor tests conforming to Method II in Table 4 of Article 10.10 of ANSI C57.12.90. The power factor shall be equal to or less than 0.5% at 20°C.
 - N. Lightning impulse tests on all winding terminals, with transformer's own bushings in place.
3. Perform the manufacturer's standard tests on each surge arrester.

8.5 PLANT AUXILIARY TRANSFORMERS

Transformer shall be suitable for operation throughout the full ambient temperature operating range. The method of cooling shall be ONAN/ONAF. Transformers shall have a minimum efficiency of 99.5% at the top rating. Transformer spare capacity at the top ONAF rating may drop below 20% when one auxiliary transformer is out of service. The

following requirements are to be used in conjunction with the applicable sections of the Owner's specifications for transformers 'Material Specification ZS 001, dated October, 2007, Substation Equipment – Power Transformer All Ratings' included in Appendix F.

On initial selection of transformer supplier, Contractor shall provide Owner with the guaranteed load and no load losses for the auxiliary transformers at the top ONAF rating. In the event the tested losses are greater than the guaranteed losses, Contractor shall reduce the contract price by the sum of \$4,000/ kW for no load losses above the guaranteed value and \$1,700 / kW for the load losses above the guaranteed value. The no load and load loss evaluation will be performed independently of each other. In the event losses are less than the guarantee value, the Contract Price shall be increased by the sum of \$2,000 / kW for no load loss differential plus \$850 / kW for the load loss differential.

The continuous rating of the unit auxiliary transformers shall be as required to supply electrical power to the total plant (two combustion turbines and one steam turbine) auxiliary load under all operating conditions but not to exceed 4160 volt switchgear capability. Transformers shall be 100% redundant. The transformer impedance shall be selected to provide adequate voltage regulation and motor starting capability under all operating conditions.

All equipment shall conform to the applicable standards of ANSI, NEMA, and IEEE, and shall be in accordance with the applicable requirements of OSHA standards. The latest published edition of referenced standards shall apply.

The power transformers shall be designed, fabricated, and tested in accordance with ANSI C57.12 series,C62, NEMA TR 1, and these Specifications.

Transformers shall be provided as a minimum with the following accessories and capabilities:

1. 4 (four) full capacity 2 1/2% taps, 2 (two) above and 2 (two) below nominal voltage rating for manual "no-load" operation.
2. Standard angular displacement of voltages.
3. Sound level not to exceed 85 dBA at 3 feet at the top ONAF rating.
4. Continuous over excitation capability of 110% at full load and 125% for 30

seconds.

5. Manholes located in cover.
6. Lockable tap changer handle accessible from ground level.
7. Short circuit capability with only transformer impedance limiting fault current.
8. Accessible core ground bushing and well for core ground.
9. Detachable radiators with lifting eyes and upper and lower isolation valves.
10. Upper and lower filter connections with sample valves.
11. Qualitrol temperature monitor with a minimum of 8 output contacts, diagnostic alarm, communications capability, and analog outputs.
12. Oil temperature and level gauges.
13. Pressure relief device with a semaphore visible from ground level.
14. Control cabinet with latchable doors.
15. Adequate number of current transformers with relay accuracy of C800 and metering accuracy of 0.3B1.8 (or as required by interconnect standards) for plant metering and relaying. At least one set of CT's on primary shall have metering accuracy. Current transformers shall have a minimum thermal rating factor of 2.0.
16. Sudden pressure relay device.
17. Serveron on-line gas analysis monitor with communications capability to the plant DCS, alarm and configurable analog outputs.
18. Copper windings with EHV-Weidmann insulation and materials suitable for 120° C continuous operation.
19. Maximum core flux density of 1.7 Tesla at no load and 100% rated tap voltage.
20. Fall protection device mounting provisions.
21. Grounding resistor.
22. Local annunciator with common alarm.
23. High temperature gasket material (Viton).

Factory Tests:

1. Notify Owner not less than two weeks prior to the starting date of the factory tests to permit observers to be present during the factory tests.
2. Procedures for factory tests shall conform to ANSI C57.12.90, unless otherwise specified. Except where a specific test method is specified, the factory test report shall state the test method used. Perform the following factory tests on each transformer unless otherwise stated:

- A. Winding ratio on rated voltage connections and on all tap positions.
 - B. Winding polarity and phase relation on the rated voltage connections.
 - C. Excitation loss at 100% and 110% of rated voltages on the rated voltage connections.
 - D. Excitation current at rated voltages, and at 110% rated voltages, on the rated voltage connections.
 - E. Impedance and load loss at the maximum 65°C rating.
 - F. Temperature rise at the maximum 65°C rating for the transformer supplied under this contract. Records of temperature tests performed on duplicate or essentially transformers will not be acceptable.
 - G. Temperature indicator accuracy test.
 - H. Applied potential test.
 - I. Induced potential test with the transformer connected at rated voltage, with the transformer's own bushings in place, accompanied by partial discharge monitoring (to conform to ANSI C57.12.90).
 - J. Lightning impulse tests on all winding terminals, with the transformer's own bushings in place.
 - K. Switching surge tests on the high-voltage winding, with the transformer's own bushings in place.
 - L. Test all control wiring for continuity, grounds, and correct connections; and test operation of all relays, indicators, switches, lights, and interlocks.
 - M. Resistance measurements of all windings on the rated voltage connection and all load tap connections. Test results shall be reported in ohms at 75°C
 - N. Doble insulation power factor tests conforming to Method II in Table 4 of Article 10.10 of ANSI C57.12.90. The power factor shall be equal to or less than 0.5% at 20°C.
3. Perform the manufacturer's standard tests on each surge arrester.

8.6 4160 VOLT METAL-CLAD SWITCHGEAR

8.6.1 General

This section covers the furnishing of 4160 volt vacuum metal-clad indoor switchgear equipment, material, and accessories. Equipment shall be provided in accordance the conceptual one-line diagram. Switchgear will have continuous ratings as required and

short circuit duty of 350 MVA. Switchgear shall be draw-out type, with provisions for locking in the drawn-out position. Switchgear shall be arc-resistant. Switchgear will be of the same type and manufacture.

The continuous current rating, short-circuit interrupting capability, and short time current carrying capability of the 4160 volt switchgear and 4160 volt motor control center shall be coordinated with the ratings of the unit auxiliary transformer and the characteristics of the connected loads. All motors rated 4000 volts and all 480 volt secondary unit substations shall be supplied directly from the 4160 volt switchgear or 4160 volt motor control center. The 4160 volt switchgear shall be furnished with potential transformers and current transformers as required for protective relaying, metering, and control. Provide surge arresters on mains and feeder breakers.

Switchgear main bus shall be fully insulated copper. Control power shall be 125 VDC with mains, tie, and feeders controlled from the plant DCS.

Relays will be configured to detect faults or abnormal operating conditions and trip appropriate breaker or alarm operator and coordinated with other protective devices. Any trip operations will include lockout functions to block closing of breakers without operator intervention. Motor feeders 2500 hp or larger shall be provided with differential protection.

Provisions and space for future expansion of each line-up shall be provided.

8.7 4160 VOLT MOTOR CONTROL CENTERS

8.7.1 General

These specifications cover 4160 volt, general purpose, indoor motor control centers. The continuous current rating, short-circuit interrupting capability, and short time current carrying capability of the 4160 volt motor control center shall be coordinated with the ratings of the unit auxiliary and the characteristics of the connected loads. Motor control centers shall be arc-resistant.

The motor control centers shall be designed and fabricated with all normally supplied accessories for use on a 4160 volt, 3-phase, 60-hertz, 60 kV BIL, resistance grounded system, and shall be coordinated to protect motors over the complete range of overload

and fault conditions. Construction of Motor Control Centers shall allow either one-high or two-high arrangements. Motor control centers shall be of the draw-out type, with provisions for locking in the drawn-out position. Lifting apparatus shall be provided for the two-high arrangements. Provisions shall be made, including space, so that the Motor Control Centers can be extended to include additional sections in the future. . Motor control centers shall be furnished with necessary ground connections, properly sized for interface with field ground cables.

8.7.1.1 Codes and Standards

All motor starters and motor control center components shall be designed and fabricated to conform to the requirements of NEMA standards for Class E-2 Industrial Control Equipment and to the requirements of applicable IEEE and ANSI standards. All materials and devices shall be in accordance with the applicable requirements of the Federal "Occupational Safety and Health Standards". The latest edition of these codes and standards shall be applied to the manufacture of the equipment

8.8 480 VOLT SECONDARY UNIT SUBSTATIONS

8.8.1 General

The equipment shall include coordinated assemblies of incoming line, transformer, and outgoing feeder sections with all auxiliary and transition compartments necessary to provide unit substations ready for installation, connection, and immediate service.

Secondary unit substations shall be main-tie-main configuration, with coordinated pairs of switchgear that are normally fed from separate sources (normally open tie breaker), and with transformers, main breakers and tie breaker sized such that the entire double-ended pair of unit substations can be fed from a single source.

Each power transformer included with each secondary unit substation shall be rated to supply the total 480 volt auxiliary load plus 30 percent under all operating conditions and 110% of the auxiliary load when the tie breaker is closed and one transformer is out of service. The transformer impedance shall be selected to provide adequate voltage regulation and motor starting capability under all operating conditions. The continuous current ratings and interrupting ratings of the main breakers, tie breakers, feeder breakers, and main bus shall be coordinated with the ratings of the power transformers and the connected loads. Breakers shall be drawout air magnetic units. The secondary

unit substations shall include feeder breakers required to supply the connected load, plus one additional equipped space for future use on each bus.

Overload and fault protection for loads connected to the 480 volt secondary unit substations shall be provided by solid-state trip devices which are an integral part of the drawout type air circuit breakers or separately mounted panel devices. Integral trip devices shall include long time, short time, instantaneous, and ground functions as required for a coordinated system. Trip units shall display metering information. If required, auxiliary power shall be provided for trip unit display at low loads.

General arrangement of unit substation shall be as indicated on the conceptual one-line diagram. This Contract shall provide substations of quantity and sizes to support the plant loads. One spare breaker of each frame rating (except for mains) shall be included for future use. Main and tie breakers shall have same rating and be electrically operated. MCC feeder breakers shall be manually operated.

Transformers for 480-volt secondary substations may be oil filled or cast coil for outdoor applications, or vacuum pressure impregnated (VPI) dry type for indoor applications. If dry type, they shall be indoor close coupled to 480-volt switchgear. Oil transformers shall have a maximum of 65° C rise, cast coil 80°C rise, and VPI 115°C rise. Oil filled units shall have high side BIL of 60 kV and low side BIL of 30 kV, ventilated dry type shall have BIL of 45 and 10 kV respectively, and cast coil 75 and 30 kV respectively. Transformers shall be low loss units and have a minimum efficiency of 99%.

Transformers shall have the following accessories:

1. Externally operated no load tap changer (for oil type), bolted taps on dry type.
2. Lower drain valve and liquid sampling device (for oil type).
3. Dial-type thermometer with contacts for cooling control and high-temperature alarm.
4. Magnetic liquid level gauge with alarm contact for low level (for oil type).
5. Pressure/vacuum gauge (for oil type).
6. Lifting lugs and jacking pads.
7. Pressure relief device (for oil type).
8. Two ground pads, on diagonally opposite corners.
9. All other standard accessories.

8.8.1.1 Codes and Standards

Unit substation components furnished under these specifications shall be in accordance with the requirements of applicable IEEE, NEMA and ANSI standards. All materials and devices shall be in accordance with the applicable requirements of the Federal "Occupational Safety and Health Standards". The latest edition of these codes and standards shall be applied to the manufacture of the equipment

8.9 480V MOTOR CONTROL CENTERS

8.9.1 General

The Contractor shall furnish and install motor control center equipment, materials, and accessories as specified herein. The motor control centers shall be designed and constructed for use on a 480 volt, 3-phase, 60-hertz, 3-wire, solidly grounded system. Except as specified otherwise, all equipment shall be designed for service with an ambient temperature of 40°C.

All equipment furnished under these Specifications shall conform to applicable standards of IEEE, ANSI, and NEMA. Motor control centers shall conform to UL 845, NEMA ICS1, NEMA ICS2, NEMA ICS4, and NEMA ICS6. All materials and devices shall be in accordance with the applicable requirements of OSHA standards. The latest edition of these codes and standards shall be applied to the manufacture of the equipment.

The continuous current rating of the motor control center main bus shall be as required to supply the total running load under all operating conditions, plus a 20 percent design allowance. The bus bracing and the interrupting ratings and continuous current ratings of the combination starters and feeder breakers shall be based on the available fault current and the characteristics of the connected loads. Each motor control center shall include the combination starters and feeder breakers required to supply the connected load, plus 10% spare units for each type size 3 and smaller. Motor control centers main breakers shall be protected by an adjustable long-time and short-time solid state trip device element for phase protection.

Each magnetic starter within an MCC which supplies power to a motor shall be equipped with a magnetic-only molded case circuit breaker and a microprocessor based overload system. Starters shall be supplied with control power transformers.

Certain loads will be fed from MCC feeder circuit breakers. The breakers shall be thermal magnetic molded case breakers sized to protect supply cable and individual loads.

All starter units and feeder tap units shall be readily interchangeable with units of the same type and size. At least one spare starter unit of each type and size used in that MCC shall be provided for future use in each motor control center. MCC's shall have provisions and space to expand at least one vertical section.

All units, except Size 5 starter units and 400 ampere frame or larger feeder tap units, shall be automatically disconnected and connected to the bus as the units are removed or replaced in the motor control centers. Size 5 starter units and 400 ampere frame or larger feeder tap units shall have fixed mounting within the motor control centers.

8.9.2 Circuit Breakers

Each combination starter unit and each feeder tap unit shall include one 3-pole, single-throw, 600 volt, molded case air circuit breaker with the appropriate amperes symmetrical interrupting rating at 480 volts. All breakers shall be manually operated with quick-made, quick-break, trip-free mechanisms of the toggle type. The breakers shall be equipped with suitable arc quenching devices. Main current carrying contacts shall be silver-plated and shall be capable of carrying their rated current without exceeding the Underwriters' Laboratories specified temperature rise. All circuit breakers shall be of the same manufacture.

Manual operating handles shall be furnished on the access doors of starter units and feeder tap units to operate the circuit breakers. Provisions shall be made for padlocking each handle in the open position. Each operating handle shall indicate when the breaker has tripped automatically.

The access doors shall be interlocked with the operating handles to prevent opening the doors normally when the circuit breakers are in the closed position. Provisions shall be made for overriding this interlock.

8.9.3 Combination Starter Units

All combination magnetic full voltage starter units shall include disconnecting and branch

circuit over-current protective devices; 480 to 120 volt dry-type control transformers; 480 volt, 3-phase, 60 hertz contactors with microprocessor based overload relays. Control transformer leads, starter overload relay contacts, contactor operating coils, and starter auxiliary contacts shall be wired to marked unit terminal blocks.

Disconnected and branch circuit over-current protection devices shall be magnetic instantaneous trip-only type circuit breakers as previously specified under Circuit Breakers.

8.10 GENERATOR TERMINAL EQUIPMENT/ISOLATED PHASE BUS DUCT

The generator terminal equipment includes the isolated phase bus duct, the generator circuit breakers, the generator transformer, and associated auxiliary equipment. The generator terminal equipment shall provide the interface between the steam turbine generator, combustion turbine generator, and the generator step-up transformers and neutral connections of steam turbine generator. Bus duct shall be selected with suitable continuous, momentary, and BIL ratings for this application and consistent with the applicable standards and considering operating and environmental conditions. Bus shall be provided with pressurized air system or heaters to prevent condensation. Bus shall include appropriate seals for connection to hydrogen cooled generators. System shall include adequate gauges, alarms, and controls for automatic operation.

8.10.1 GT Generator Bus Duct/Auxiliary Power Connections

Generator bus duct shall connect generator line terminal unit to the generator breaker and then to the generator step-up transformer with taps to the auxiliary transformers as depicted on the conceptual single-line drawing. Bus duct shall be self cooled with suitable continuous, momentary, and BIL ratings for this application and consistent with the applicable standards and considering operating and environmental conditions. The bus shall be a low loss design. The bus shall include seals at the generator terminals.

Tap bus shall be provided for connection to the auxiliary transformers. Tap bus shall have suitable momentary and continuous ratings.

Bus duct shall be provided with wall bushings / vapor barriers at transitions from indoor to outdoor sections.

8.10.2 Low Side Generator Breakers

A generator breaker shall be provided between the combustion turbine and generator step-up transformer. Each generator circuit breaker shall have a continuous current rating at least 125% of generator rating to transmit the generator output under all normally expected loading conditions. Each breaker shall have a short-circuit interrupting capability and short-time current carrying capability which is equal to or greater than the fault current available under any operating conditions. The potential transformers and current transformers shall be furnished as required for protective relaying, metering, and synchronizing of the generator to the grid.

The surge protection equipment shall include surge arresters and capacitors. The surge protection equipment shall be coordinated with the characteristics of each generator to provide protection for each generator insulation system. Generator breaker shall be provided with dual tripping coils, transformer side surge protection, generator side surge capacitor, isolation switch, grounding switch and generator side grounding switch. The generator breaker shall include all material required for termination of the isolated phase bus duct. Breaker shall be provided with adequate number of current and potential transformers to implement protective relaying as specified or required. At least one PT shall be a broken delta configuration with ferroresonant loading resistor.

Access platforms shall be provided for the normal maintenance and operation of the units.

8.10.3 ST Generator Bus Duct

Generator bus duct shall connect the steam turbine generator directly to its step-up transformer. Provide PT and surge cubicle, and steam turbine bushing terminal enclosure. The isolated phase bus duct and tap bus shall have a continuous current rating as required under all normally expected loading and ambient conditions and suitable momentary ratings. The bus shall include seals at the generator terminals.

All medium voltage, isolated phase bus duct and accessories shall be designed, fabricated, and tested to the latest applicable standards of NEMA, IEEE, and ANSI. The latest editions of these codes and standards shall apply.

8.11 NON-SEGREGATED PHASE BUS DUCT

8.11.1 General

Bus duct shall have continuous and short circuit ratings equal or exceeding all equipment connected to the bus. Bus shall be non-ventilated and include all hot-dipped after fabrication support structures. Flexible connections shall be provided at each termination point to allow for differential settlement. Appropriate sealing method shall be provided for wall penetrations.

8.11.2 Bus Enclosures

Bus enclosures, fitting enclosures, and termination enclosures shall be ventilated-type for indoor locations and totally enclosed non-ventilated type for outdoor locations. Enclosures shall be fabricated from heavy gauge steel or aluminum with removable covers for access to splice points and heaters. All covers or access points shall be gasketed. Welded or riveted connection means shall be used for non-removable construction. Top covers shall be solid, removable, and gasketed. Removable bottom covers shall be provided where required for splice access. Bottom pan shall have filtered breathers for outdoor section. All steel framing and panels shall be chemically cleaned and phosphatized prior to painting. All outdoor and indoor sections shall be painted. Bus enclosure shall be such that mating parts with termination boxes, elbows, wall seal sections, and tees shall fit properly without warping, gapping, or distortion of the enclosure or accessories. Connections between joining sections of enclosures or accessories shall be bonded by the enclosure design or by jumpers to ensure electrical continuity of the enclosure. The enclosure shall be designed to be hung from overhead (indoors) or supported from below (outdoors). The bus duct manufacturer shall supply all support hardware, hangers, and pedestals.

8.11.3 Bus Conductors

Bus conductors shall be multiple flat bar copper with silver plating at connections with flame-retardant, track-resistant insulation, mounted on insulated supports. Bar size and quantity per phase shall be such that the continuous current rating specified shall not cause bar temperature rise exceeding 65°C above a 40°C ambient. Bars shall be insulated with "Noryl" sleeving or dipped with a fluidized bed epoxy coating. Bars shall be mounted within the housing with flame retardant, molded, reinforced fiberglass supports. Bars shall be braced to withstand the available fault currents specified. Splice

points shall use bolted connections that are accessible after installation for inspection. Splices shall be fully insulated after installation with flame retardant PVC boots or flame retardant insulating tape and jacketing tape.

8.12 BATTERY/UPS SYSTEM

This section covers furnishing a generating station unit battery complete with charging system. Additionally, this section covers the furnishing of power conversion switching and distribution equipment for continuous supply of electric power to critical AC loads.

8.12.1 Codes and Standards

All equipment furnished under these specifications shall conform to applicable standards of IEEE, ANSI, and NEMA. All materials and devices shall be in accordance with the applicable requirements of the Federal "Occupational Safety and Health Standards." The latest edition of each code and standard shall apply.

8.12.2 Design and Construction

Each battery cell shall be wet cell, lead-acid pasted plate-type with lead-calcium alloy plate grids or sealed type with 20-year expected life. Cell containers shall be sealed, clear, shock absorbing, heat resistant plastic, with electrolyte high and low-level markers and spray-proof vents. Batteries shall be manufactured for full float service with a high discharge rate, low deterioration rate, and low maintenance. Batteries shall be supplied complete with all accessories (e.g. battery rack, inter-cell connectors). Racks shall be a 2 step configuration. Battery shall be installed in protected room ventilated with conditioned air. Battery shall have a final discharge voltage of 1.75 volts per cell and a design temperature of 25° C.

The DC power supply equipment shall include one battery (number of cells as required) of required voltage to provide 125-volt DC power for plant switchgear control power, protective relaying, steam turbine loads, and to the essential service AC system; two redundant ferro-resonant battery chargers for each battery; DC switchboard, and DC panelboards as required. The equipment shall supply DC power in emergencies to protect power plant equipment (UPS) and to ensure the safety of operating personnel. The equipment shall provide power to trip circuit breakers, to energize emergency bearing oil pumps, emergency lighting, continuous AC power supply equipment, and critical control and protection systems.

Each CTG is supplied with its own dedicated DC power system for combustion turbine DC loads.

The DC switchboard and panelboards shall have a main bus current rating as required to supply the connected load. Battery leads to switchboard shall be run in individual raceways for each pole. The continuous current ratings and interrupting ratings of the feeder breakers shall be based on the available fault current and the characteristics of the connected loads or the battery chargers. Each panelboard shall include the feeder breakers required to supply the connected loads plus six two-pole feeder breakers for future use. Switchboard shall include bus voltmeter, battery ammeter with shunt, ground detection and alarm, and low voltage alarm.

8.12.3 Rating

The Contractor, in accordance with IEEE 485 and these Specifications, shall determine the capacity of each battery. With the actual discharge capacity of the battery at 80% of rated discharge capacity, with the battery initially fully charged at the floating voltage specified, and with the battery chargers disconnected, the battery shall be capable of supplying the duty cycle specified. The ambient temperature during the duty cycle shall be 30° C. An aging factor of 25% and design margin of 20% shall be used. Contractor shall submit battery calculations for approval.

8.12.4 Duty Cycle

The batteries shall be sized to safely shut down the plant under emergency conditions without a source of auxiliary power or station service power. The station battery shall also have adequate capacity to supply emergency lighting, continuous AC power supply equipment, and critical control and protection systems for a period of three-hours following an emergency shutdown.

8.12.5 Battery Charger Requirements

Each battery charger-eliminator furnished shall be self-regulating, natural cooled, solid-state silicon controlled full wave rectifier type designed for single and parallel operation with the batteries specified under these Specifications. The parallel operation features of the battery chargers shall include cross-compensation providing for equal sharing of the charger loads. Chargers shall be able to provide the DC load requirements in the event that batteries are disconnected.

The chargers will be served from a 480 volt, 3-phase, 60 hertz system.

The battery chargers shall maintain output voltage within plus or minus ½% from no load to full load, with an input power supply deviation in voltage level of plus or minus 10% and an input power supply deviation in frequency of plus or minus 5%.

Solid-state electronic circuits shall have AC and DC transient voltage protection and shall be designed to recharge a totally discharged battery without overloading and without causing interrupting operation of AC or DC circuit breakers.

Redundant chargers shall be provided for each battery. Charger shall be a full capacity charger. Each charger shall have the capacity to carry the continuous load and recharge the battery in 8 hours following complete discharge. Battery chargers shall also have a equalizing charge mode. Battery chargers will be self-regulating after charging levels are manually selected. Battery chargers shall be manufactured in NEMA 1 enclosures suitable for placement in an indoor, environmentally controlled atmosphere. The battery chargers shall require only front access, and will allow either top or bottom conduit/cable entry.

8.12.6 UPS Equipment Requirements

The continuous AC power supply equipment includes a voltage regulator, inverter, static transfer switch, a manual bypass switch, and distribution panelboard. The equipment shall provide 120-volt AC power to essential plant control, safety, and information systems.

The equipment shall supply all plant essential loads that would be affected by a loss of power of more than 1/4 cycle and excessive voltage and frequency deviations. The equipment shall be rated so that one inverter can supply the total plant essential loads plus 10% for future expansion. The distribution panelboard shall have a main bus current rating as required to supply the connected loads plus six single-pole switches for future use. The ratings of the fuses shall be coordinated with the characteristics of the loads and the capabilities of the inverter. In addition to the plant loads furnished by this Contract, Contractor shall include critical AC loads for the combustion and steam turbine including HMI's, hydrogen control panel, fuel gas regulator station, communication equipment, SCADA RTU's, and other critical loads determined during design.

The following equipment shall be designed and assembled to provide 120 volt, single-

phase, 60 hertz power to a 2-wire uninterruptible AC power system;

- 1 Static Inverter
- 1 Full Capacity Static Switch
- 1 120 Volt AC Distribution Panelboard
- 1 Manual Bypass Switch
- 1 Voltage Regulating Transformer

All equipment, enclosures, and accessories shall be designed, arranged, assembled, and connected in accordance with the requirements of these Specifications.

8.12.6.1 Static Inverter

The static inverter shall be solid-state type employing silicon controlled rectifiers and other required solid-state devices to convert direct current power to essentially sinusoidal alternating current power, and shall conform to the following characteristics and requirements:

Voltage	
Output	120 volts, single-phase, 60 hertz
Input (battery)	105 to 140 volts DC
Harmonic Distortion	Not more than 5%, 0 to 100% load
Voltage Regulation	Not more than plus or minus 2% at 0 to 100% percent load, 1 .0 to 0.8 power factor, 105 to 140 volts DC Input
Output, Self-Regulated	Automatic, not more than plus or minus 0.5% 0 to 100% load
Efficiency	Not less than 80% at rated load and 1.0 power factor
Duty	Continuous
Cooling	Natural convection or forced air cooling
Ambient Temperature	0-50°C maximum, 35°C normal
Minimum SCR De-rating	50% from peak voltage and peak current ratings

8.12.6.2 Inverter Capacity

The static inverter shall have the following minimum capabilities:

Continuous Full Load Rating	The inverter shall be sized to supply power for 110% of the Plant's critical 120-volt AC loads with 125% overload capability for 10 minutes.
Step Load Pickup	Upon transfer of full load, the inverter output voltage shall not drop below 75% of nominal voltage during the first half cycle after transfer and 90% of nominal voltage subsequently.
Fuse Clearing	Upon a fault in any branch circuit lateral feeder, the inverter shall have the capacity to carry a load equal to one-half of its full load rating and clear a 30-ampere, fast-acting fuse in 4 milliseconds (1 /4 cycle) or less. This requirement shall be met if the static switch fails to transfer from the inverter to the alternate source.

8.12.6.3 Static Transfer Switch

The static transfer switch shall use silicon-controlled rectifiers and other static devices required to automatically transfer loads from the "Normal" source to the "Alternate" source. The static transfer switch shall conform to the following requirements:

Capacity, continuous	Equal to the continuous full load capacity of the inverter
Capacity, peak	1,000 percent of continuous rating for 5 cycles
Voltage	120 volts, single-phase
Frequency	60 hertz
Transfer time sensing,	Including 1/4 cycle maximum. Transition shall be "make before break." Voltage failure shall be sensed on the output of the static switch. Failure shall cause the static switch to transfer. The static switch shall also transfer on over-current prior to the inverter reaching a current limit mode.
Voltage transfer to "Alternate" source	Automatic transfer to alternate source When output voltage of inverter deviates plus or minus 10 percent from nominal

Over-current transfer to "Alternate" source	Continuously adjustable from inverter Continuous rating to inverter current limit rating
Retransfer to "Normal"	Return to normal shall be automatic for all source externally caused transfers such as overload or clearing of a branch circuit fuse, but shall be manual for all internally caused transfers such as inverter, filter, or normal patch failure.
Overload	125 percent for 2 minutes
Line voltage transient	170-volt peak above normal line voltage tolerance
Ambient temperature	0-50°C maximum, 35°C normal
Cooling	Natural convection or forced air cooling
Duty rating	125% Continuous

The static switch shall be provided with protective fuses in both "Normal" and "Alternate" power sources. The static transfer switch shall be furnished mounted in enclosures described later in these Specifications.

8.12.6.4 Manual Bypass Switch

A manual bypass switch shall be used to isolate a static switch from its load and alternate power supply and to take it out of service without power interruption to the load. In so doing, it will connect the load bus to the alternate source. It shall have make-before-break contacts, so that power supply to the loads is continuous during switch operations. It shall be rated 600 volts, single-phase, 60-hertz, and shall have a continuous rating 125% of output rating.

8.12.7 Distribution Panelboards

Panelboards for distribution of continuous AC power to essential loads shall be dead-front type panelboards rated 120 volts AC. The hinged panelboard front shall cover the fuses and wiring gutter, but not the switch handles. The enclosure door shall cover the hinged front and switch handles.

Each panelboard shall be constructed for a 2-wire, single-phase distribution with a solid neutral bar. Phase and neutral bars shall be copper. Rating of the main lugs shall be equal to the rated continuous full-load current of the inverter.

Each panelboard shall have sufficient quantity single-pole, branch circuit protective

devices to serve all loads plus 25% spare. Circuit protective device sizes required will be determined by Contractor.

Circuit identification labels or tags shall be provided on the panelboard front.

8.12.8 Construction Details

Details of construction shall conform to the requirements of the following paragraphs.

Enclosures shall be ventilated switchboard type, fabricated from not less than 14 USS gage sheet steel. Enclosures shall be designed to permit easy access to all components for maintenance or replacement. The enclosures shall be reinforced with formed steel members as required to form a rigid self-supporting structure. Doors shall have three-point latches.

Adequate ventilating louvers and openings and enclosure top panels shall be included. All vent openings shall be covered with corrosion resistant fine screen coverings.

If the equipment supplied requires forced air cooling, the cooling system furnished shall meet the following requirements.

1. Reserve cooling equipment shall be furnished for each switchboard assembly. Reserve fan capacity shall be equal to 100% of cooling fan requirements for full-load operation at the specified maximum ambient temperature.
2. Completely independent duplicate wiring and control systems shall be provided for the normal cooling fan system and the reserve cooling fan system.
3. Each cooling fan shall normally run continuously and shall be powered from the output of the inverter. Each cooling fan supply circuit shall be separately fused.
4. Each cooling fan shall be equipped with an airflow switch having an alarm contact that closes upon failure of airflow.

8.13 EMERGENCY DIESEL GENERATOR

8.13.1 General

Furnish and install an outdoor self-contained integrally assembled low-emission emergency diesel generator system to automatically start and energize critical busses in the event of loss of station power. Critical loads include loads to keep combustion turbine in the ready to start condition, battery chargers, turning gear, seal oil pumps, lube oil pumps, emergency lighting, and other loads as developed during the design phase.

8.13.2 Design and Operation

Unit shall be designed for No. 2 fuel oil with an integral day tank for 18 hours operation before filling. Heaters shall be provided to maintain water temperature to allow unit to be brought to full load within 30 seconds of starting. Provide day tank fuel oil heaters if required due to low ambient temperatures. Provide local panel for control and monitoring of unit. Unit shall be capable of remote control from the plant distributed control system. Unit shall be capable of automatic starting and synchronizing to hot or dead bus. Include any required fire protection equipment.

8.14 ELECTRIC MOTORS

Except for valve motor operators (specified elsewhere), these motor specifications are applicable to all electric motors furnished under these Specifications. Special requirements for individual motors and specifications for special application motors are included in the equipment technical sections, as required. All motors shall be Premium Efficiency.

All motors shall conform to applicable standards of ANSI, IEEE, NEMA, and AFBMA, except where modified or supplemented by these specifications. All equipment and materials shall be in accordance with the applicable requirements of the Federal "Occupational Safety and Health Standards." The latest edition of these codes and standards shall apply.

The motor nameplate horsepower multiplied by the motor nameplate service factor shall be at least 15% greater than the driven equipment operating range maximum brake horsepower. Motor ratings shall be based on site maximum design ambient temperature.

Any motors used in variable frequency applications , such as air-cooled condenser fans, shall be rated for the application and type of drive.

Motors shall be designed for full voltage starting and frequent starting where required, and shall be suitable for continuous duty in the specified ambient. Intermittent duty motors may be furnished where recognized and defined as standard by the equipment codes and standards. Motors shall be sized for the altitude and temperature range at which the equipment will be installed.

Except as specified otherwise in the individual paragraphs or technical sections, the torque characteristics of all induction motors at any voltage from 90% rated voltage to 110% rated voltage shall be as required to accelerate the inertia loads of the motor and driven equipment to full speed without damage to the motor or the equipment.

8.14.1 4000 and 460 Volt Integral Horsepower Motors

Motors $\frac{3}{4}$ - hp to 200-hp shall be rated 460-volt, 3-phase, 60-hertz. Motors 250-hp and greater shall be rated 4000 volt, 3-phase, 60-hertz. Design and construction of each 460-volt integral horsepower motor shall be coordinated with the driven equipment requirements and shall be as specified herein. Any exceptions shall be approved by Owner.

The following nameplate data shall be included:

1. Starting limitations, if any.
2. AFBMA bearing identification number for motors furnished with rolling element bearings.

For motors designed for service in hazardous areas:

1. Location class and group design.
2. Maximum operating temperature value or operating temperature code number.
3. All other motor data such as horsepower, FLA, service factor and related items.
4. All motor nameplates and attachment pins shall be corrosion-resistant metal.

All motors shall be self-ventilated unless required otherwise.

Enclosure parts for all motors (e.g., frames, bearing brackets, external fan covers) shall

be made of cast iron, cast steel, sheet steel, or steel plates. Aluminum enclosure parts are not acceptable. All open-type motors and the fan covers of totally enclosed fan-cooled motors shall meet NEMA MG 1 requirements for a fully guarded machine.

Totally enclosed motors shall be furnished with drain holes and rotating shaft seals. Drain holes shall be provided with Crouse-Hinds Type ECD "Universal" combination water drain-breather plugs, or approved equal. Motors for outdoor service shall have all exposed metal surfaces protected with a corrosion-resistant polyester paint or coating.

In addition to the preceding requirements for outdoor service motors, totally enclosed motors with NEMA waterproof features shall have enclosure interior surfaces and the stator and rotor air gap surfaces protected with corrosion-resistant alkyd enamel or with polyester or epoxy paint or coating. Bolts, nuts, screws, and other hardware items shall be corrosion-resistant or heavy cadmium-plated metal. A rotating labyrinth shaft seal shall be furnished on the shaft extension end of the motor.

Motors specified for Class I, Group D locations shall be UL approved and labeled.

Except as specified in the following paragraph, all insulated windings shall have Class F Non-hygroscopic insulation systems limited to class B rise. Motors larger than 200 hp shall be provided with sealed insulation systems and be abrasion resistant for any open motors.

All insulated winding conductors shall be copper. The winding temperature rise for all motors, when operating at the nameplate horsepower multiplied by the service factor shall not exceed 80°C. Motors larger than 200 hp shall have 2 embedded RTD's per phase.

All motors furnished in NEMA 180 Frame Series or larger shall have space heaters. Space heaters shall be rated a 120 volts, single-phase, 60 hertz. Space heaters shall be sized as required to maintain the motor internal temperature above the dew point when the motor is idle. The space heaters shall not cause winding temperatures to exceed rated limiting values, nor cause thermal protective device "over temperature" indication when the motor is not energized.

Terminal housings for totally enclosed motors shall be cast iron. Terminal housings for

all other motors shall be cast iron, pressed steel, or fabricated steel. Housings shall be diagonally or longitudinally split with a gasket between the split halves of the housing. Each housing shall have a threaded opening to provide a watertight, rigid connection with the conduit, and shall be designed for rotation in 90-degree increments, or have other provisions to receive conduit from any of four directions

All leads shall be wired into the motor terminal housing. All leads and their terminals shall be permanently marked in accordance with the requirements of NEMA MG 1, Part 2. Cable-type leads shall be provided with compression-type terminal connectors. Motors 2500 hp and larger shall be provided with surge protection and current transformers for motor differential protection.

Each motor shall be furnished with a grounding connector attached to the motor frame inside the motor terminal housing. The grounding connector may be a lug or terminal or other acceptable grounding connector. Motors larger than 200 hp shall have grounding pad on frame for connection to plant ground grid.

Antifriction radial and thrust bearings shall be designed and fabricated in accordance with AFBMA standards to have a minimum: L_{10} rating life of not less than 130,000 hours for direct coupled service, and not less than 42,500 hours for belt or chain connected service. Grease lubricated radial bearings shall be double-shielded.

Oil ring lubricated-type sleeve bearings shall be provided with oil level sight glasses marked for required oil level at motor running and motor standstill. The oil ring shall be one-piece construction; split-type construction will not be acceptable. Stationary labyrinth seals shall be bronze material.

Sleeve bearings, end bells, and bearing housings for horizontal motors shall be split-type when available for the frame and the enclosure specified. Air gap measurement holes or other acceptable means will be provided in each motor end enclosure for checking air gap of sleeve bearing motors.

Sleeve bearings on horizontal motors shall be designed and located centrally, with respect to the running magnetic center, to prevent the rotor axial thrust from being continuously applied against either end of the bearings. The motors shall be capable of withstanding without abnormal damage the axial thrusts that are developed when the

motor is energized.

Motors furnished with spherical roller thrust bearings shall also be furnished with deep groove radial guide bearings. One guide bearing shall be locked to the shaft so that the guide bearing will take upward thrust and to assure that the thrust bearing is always loaded. If spring loading is furnished, the guide bearing shall not be preloaded during normal operation.

Thrust bearings for vertical motors shall be capable of operating for extended periods of time at any of the thrust loading imposed by the specific piece of driven equipment during starting and normal operation without damage to the bearing, the motor frame, or other motor parts.

Stacked antifriction bearings will not be acceptable, except as vertical thrust bearings in frame sizes up through NEMA 360 Series open-type enclosures and up through NEMA 680 Series open-type enclosures. Where stacked bearings are furnished, matched pair precision tolerance bearings with flush ground sides shall be provided. Bearing seats on the shaft and in the bearing housing shall have accuracy equal to that of the bearing.

Grease lubricated bearings shall be self-lubrication and re-greaseable. Bearings and bearing housings shall be designed to permit disassembly in the field for inspection of the bearings or removal of the rotor.

Bearing lubricants shall contain a corrosion inhibitor. The Contractor shall furnish all lubrication information required to assure proper equipment startup and subsequent bearing maintenance. All induction motors shall have squirrel-cage rotors.

Where shipment permits, motor output shafts shall be complete with motor half-coupling mounted, connected to the driven equipment, and adjusted ready for operation. Where motor size prevents shipment with motor connected to driven equipment, the motor half-coupling shall be factory-mounted for field connection to the driven equipment.

Motors shall have torque and locked rotor current in accordance with NEMA MG 1, Part 12 and sufficient to meet starting requirements of loads.

The maximum motor sound level shall be 85 dBA.

8.14.2 Fractional Horsepower Motors

Motors rated less than ¾-hp shall be rated 115-volt, single-phase, 60-hertz except for valve or damper operators. Motor rating, service factor, and nameplate data shall conform to the requirements of NEMA MG 1 standards.

Motor nameplate horsepower ratings shall not be exceeded when the equipment is operating within the limits of the design conditions specified. The motor loading shall not exceed the motor service factor rating on startup conditions or at the equipment maximum load point.

All motors shall be self-ventilated. Fully guarded enclosures shall be furnished on all motor enclosure types having accessible moving parts other than shafts. All insulated winding conductors shall be copper. Shafts of motors shall be furnished with corrosion-resistant treatment or shall be of corrosion-resistant metal.

Capacitors, as required, shall be furnished in removable metal enclosures mounted on the motor frame. Lock washers shall be provided under the heads of the enclosure hold-down bolts.

Manual reset thermal protection, for both stalled rotor and overload protection, shall be furnished on all motors where available unless specified otherwise in the individual technical sections. All motors shall be completely assembled with the driven equipment, lubricated, and ready for operation.

8.15 RACEWAY

This section covers furnishing and field installation of a complete raceway system in accordance with these specifications.

The raceway system is defined to include conduit, flexible conduit, continuous rigid cable supports called "cable tray" herein, underground duct, wireway, cabinets and boxes, and all materials and devices required to install, support, secure, and provide a complete system for support and protection of electrical conductors.

The design and specifications for the raceway system used in supporting and protecting electrical cable shall be in accordance with the provisions of the NEC. Fire stops shall be

provided wherever raceways penetrate floors or fire rated walls.

Individual raceway systems shall be established for the following services:

1. 4160 volt power.
2. 480 volt and 125 Vdc power.
3. 600 volt control cable.
4. Special electrical noise-sensitive circuits or instrumentation cable.
5. Lighting
6. Fiber optical

Lighting branch circuits, telephone circuits, fiber optic cables, and intercommunication circuits shall be routed in separate conduit systems. Lighting circuits shall be routed in electrical metallic tubing (EMT) for indoor concealed areas, rigid conduit for hazardous exposed and outdoor areas, and polyethylene (PVC) tubing or Schedule 40 PVC conduit for underground.

Hot dipped galvanized conduit (after fabrication) shall be used for above ground power control wiring. Fiberglass or aluminum tray and conduit shall be used for corrosive areas.

Rigid galvanized steel conduit shall be used for routing individual circuits from the cable tray system to individual devices and pieces of equipment. Liquid-tight flexible conduits shall be used on all motor connections and all other connections subject to vibration.

All underground duct banks shall consist of Schedule 40 PVC conduit encased in concrete. Duct banks shall be reinforced at road crossings and areas subject to heavy loads. Duct banks shall have red dye incorporated in the top two inches of concrete. Galvanized steel conduit shall also be installed for digital and analog low level circuits to provide noise immunity from adjacent power circuits if required. Risers shall be concrete encased conduit. Spare ducts shall be provided in each duct bank run equal to 20% of the total number of ducts with the size of the spare ducts equal to the largest size duct in the duct bank. Duct banks shall be sloped to provide proper drainage.

Duct banks shall be assembled using non-magnetic saddles, spacers and separators as recommended by the duct manufacturer. Separators shall provide 3 inches minimum concrete between the outer surfaces of the conduits.

Duct bank routes shall be identified at 100 feet (minimum) intervals by means of a 4 inches x 4 inches concrete marker set flush with grade and with the letter "E" and an arrow cast in the top. Markers should be approximately 3 feet in length and shall be placed at the side of the duct bank to prevent puncturing of ducts if marker is run over by a vehicle.

Reinforced concrete manholes shall be provided, where required, so that cable may be installed without exceeding allowable pulling tensions and cable side wall pressures. Each manhole shall have the following provisions:

1. Provisions for attachment of cable pulling devices.
2. Provisions for racking of cables.
3. Manhole covers of sufficient size to loop feed the largest diameter cable through the manhole without splicing.
4. Sealed bottoms and sumps.

The installation specifications included in this article apply to all raceway system components.

8.15.1 Routing of Above Grade Raceway and Conduit

The Contractor shall route raceway and conduit and shall coordinate conduit locations with other equipment and structures. Raceway and conduit shall be routed so that, except where they are being lowered to enter equipment, the lowest part of the raceway or conduit, including its associated supports and appurtenances, is at least 6'-8" above the closest floor or walking surface beneath it. Raceway and conduit may be routed a reasonable distance away from the supporting wall, ceiling, or structural member so long as the specified support is provided, interference with other equipment and structures is avoided, and the routing is acceptable to the Owner. Raceway and conduit, including their associated supports and appurtenances, which must be routed closer than 6'-8" above the closest walking surface beneath it, shall be routed as close as possible to surfaces of walls, columns, and the equipment served. Conduit supports shall be spaced no longer than 10 feet. All junction, terminal, and pull boxes shall have construction suitable for the environment and area classification. Expansion couplings are required for every 100 foot.

All raceway and conduit shall be installed in a neat, rectangular form. Special attention shall be given to securing a neat appearance. All raceway and conduit shall be installed perpendicular or parallel to the major equipment, building structure, and floor levels, except in special cases consented to by the Owner.

8.15.2 Electrical Cable Tray System

An electrical cable tray system shall be furnished and installed in accordance with these Specifications. The electrical cable tray shall be in accordance with the requirements of NEMA VE 1 except that, in case of conflict between the requirements of these Specifications and the requirements of NEMA VE1, the requirements of the latter shall govern to the extent of such conflict. Tray shall be installed in a continuous system. In addition to and concurrent with the load specified in this section, the tray shall be designed to withstand a concentrated load of 200 pounds at the mid-span, at the center of the rung or on either side rail.

Cable trays shall be of ladder-type construction with a rung spacing of 6 to 9 inches, nominal depths of 4 to 6 inches, and various widths as required. Cable trays shall be supported in accordance with NEMA VE-1 standards.

Cable trays and fittings shall be the standardized products of a single manufacturer designed to permit easy assembly in the field. The parts shall consist of the manufacturer's standard straight sections, crosses, tees, reducers, flat and riser elbows, as required to suit the layout. Coupling between the members shall be manufacturer's standard. All fittings shall be designed and constructed so that (1) the assembled system will be free of sharp edges or projections on surfaces which contact the cables, and (2) the cables will not be bent, either during installation or in the final position to radii less than allowable for each respective size and type. Dropout fittings shall be provided where required to maintain the minimum cable-bending radius. Where warranted, Contractor may use tray dividers for different class cables. The fill of each of the respective sections shall not exceed NEC limits.

Solid bottom trays shall be provided for all special noise-sensitive circuits and analog instrumentation circuits. Instrumentation trays shall be of steel solid bottom trough tray, galvanized after fabrication. All instrumentation trays shall have complete coverage with solid tray covers. Standard ladder type tray without tray covers may be utilized for instrumentation circuits if this installation method and separation criteria is acceptable to

equipment vendors. In any case, shielded, twisted pairs shall be utilized for all low level signals.

All trays shall be of steel or aluminum construction, width and depth as required for application. All trays shall be designed with a safety factor of 2.0. Cable tray shall be labeled with the tray type and node designations shown on the Contractor's drawings. Labels shall be of the adhesive type and shall be applied to both sides of each tray at the locations shown on the Contractor's Drawings. Letters and numbers on the labels shall be minimum of two inches in height and shall be colored as follows:

Power Tray: Black characters on red background

Control Tray: Black characters on yellow background

Instrumentation Tray: Black characters on green background

8.15.3 Covers

Except as specified otherwise herein, all indoor vertical trough and ladder-type trays shall be furnished with ventilated covers to provide mechanical protection to cables which are exposed to traffic. All indoor horizontal trays located under grating floor or insulated pipe shall be furnished with covers which, on trough and ladder-type trays, extend at least two feet beyond that part of the trays directly exposed beneath the grating floor or insulated pipe. Indoors, covers may be omitted on those lower trays of stacked trough and ladder-type trays where a covered tray at a higher elevation in the stack provides complete vertical shielding to the lower tray. The top level of outdoor tray runs shall be furnished with covers. Trays which are specified to have solid bottoms shall also have solid covers throughout including all horizontal runs, all fittings, and all vertical runs.

8.15.4 Tray Supports

Tray supports shall be furnished and installed in accordance with these Specifications. The Contractor shall be responsible for designing the cable tray support system within the allowable limits specified by the manufacturer of the support hardware.

Each support shall be capable of supporting the uniform weight of the trays, plus their nominal uniform cable loads, plus a 200-pound concentrated load without exceeding the allowable limit of any element of the support system. The safety factor of support hardware shall not be considered in determining the suitability of any element, except

that the safety factor shall not be less than 2.0 for any support element.

Hanger rods shall not be smaller than 1/2-inch diameter electro-galvanized threaded steel rods.

8.15.5 Material

Underground duct system materials furnished under these Specifications shall be new and undamaged and shall conform to the following requirements:

Duct	Polyvinyl chloride, Schedule 40 PVC in accordance with NEMA TC-2.
Couplings	Plastic, for use with duct previously specified and "Duct-to-steel" adapters as required, including joint cement.
Spacers	Plastic high impact, interlocking, base and intermediate type
Factory bends and sweeps	Schedule 40 PVC, 36 inch minimum radius
End bells	Plastic
Plugs	Plastic, high impact, tapered to fit end bell provided
Duct binder	Hemp or sisal twine coupling
Riser termination	Rigid hot-dip galvanized mild steel coupling
Riser bends	Rigid steel conduit elbows, factory or field made, 36-inch minimum radius, 90 degree, entirely concrete encased below grade; hot-dip galvanized rigid mild steel in accordance with ANSI C80.1 and UL 6; the conduit interior and exterior surfaces having a continuous zinc coating with an overcoat of transparent enamel or transparent lacquer.

8.16 CONDUCTORS

In general, conductors shall be insulated on the basis of a normal maximum conductor temperature of 90°C in 40°C ambient air with a maximum emergency overload temperature of 130°C and a short-circuit temperature of 250°C for medium voltage

cables and 75°C for 600 volt cables. Power conductor size and ampacity shall be coordinated with circuit protection devices. Conductor minimum size shall be the largest conductor of the following:

1. Applicable standards
2. Maximum ambient temperature
3. 125 % of connected load
4. For bus feeders 100 % of connected load plus 25 % of running load.
5. 90% minimum motor terminal voltage on starting (except if motor is designed for lower terminal voltage)
6. Voltage drop from no load to full load for switchgear and MCC's excluding transformer drop per NEC.
7. Computerized thermal model of cable position in duct bank (85°F average soil temperature).
8. Cable temperature rise due to short circuit.
9. Worst environmental condition when routed through multiple areas.

Insulated cable, conductors, and conductor accessories shall be furnished and installed in accordance with the requirements of this section of these Specifications. Insulated cable, conductors, and conductor accessories shall be furnished in quantities sufficient for a complete installation as indicated in these Specifications.

Installation shall be defined to include placement, splicing, terminating conductors; coiling and taping of spare conductors; identification, testing, and verification of each circuit, cable, and conductor. Installation of cable in trays shall also include removal and replacement of cable tray covers. Installation shall be in accordance with manufacturer's requirements. Manufacturer's pulling or side wall tension shall never be exceeded. Contractor shall submit recorded cable tension reports. Cable shall be supported by conduits or tray for any cable routed over tray side wall. Any bottom exit cables shall be shall have suitable fittings. Cable in vertical tray risers shall be supported every 2 feet or less to prevent stress on cable.

Terminating a conductor shall include installing cable termination kits for shielded cable, attaching the conductor at its designated location, and insulating the entire connection where specified or required by the application.

8.16.1 Cable Specifications

The cable furnished shall be flame retardant construction meeting IEEE 1202 and UL 1581 and manufactured in accordance with the applicable ICEA standards and suitable for wet or dry locations. All cable installed in trays shall be rated for tray use. All cable shall have surface printing showing manufacture's name, insulation type, jacket type, conductor size, conductor type, voltage rating, and numbered footage markers. Control and instrument cables shall be terminated with ring tongue connectors. Compression type terminals may be utilized if this is the manufacturer's only offering. Special construction cables as required to meet equipment supplier requirements (turbine-generator) shall meet the following requirements to the extent possible in addition to meeting supplier requirements. Control, metering, and relaying cables routed to the switchyard shall have construction as follows except cable is to be shielded

The cable furnished shall conform to the cable descriptions included below:

CABLE TYPE	DESCRIPTION
Medium Voltage Power	25,000 and 5,000 volts, single-conductor and three conductor with ground, Class B stranded copper, ethylene propylene rubber (EPR) 133% insulation, conductor, insulation and tape shield; and chlorosulfonated polyethylene (CSP), polyvinyl chloride (PVC), or chlorinated polyethylene (CPE) jacketed. Where specified by OEM unshielded cables are to be used.
Low Voltage Power	600 volts, single-conductor, Class B stranded copper; EPR or XLP insulated; CPS, PVC, or CPE jacketed.
Low Voltage Power	600 volts, three-conductor; concentric lay, stranded copper with a ground wire in the interstices; FRXLPE or FREPR insulation; CSP, PVC, or CPE jacketed overall.
Control	Control cable, 600 volt, multiple-conductor, as required, stranded copper, 10 AWG, 12 AWG, 14 AWG; multiple-conductor, XLP insulation; CSP,

	PVC, or CPE jacketed overall.
Thermocouple	Thermocouple extension cable, one, four, six, and eight twisted pairs, solid alloy conductor with the same material as the thermocouples, with shield over each pair (except for one-pair construction) and with an overall shield, 16 AWG single pair; 20 AWG multi pair; FRXLPE or FREPR insulation; aluminum mylar tape shield with drain wire; CSP or CPE jacketed overall.
High Temperature Thermocouple	High temperature thermocouple extension cable, single-twisted pair thermocouple extension cable; solid alloy conductor with the same material as the thermocouples; 20 AWG; with normal maximum operating temperature of 200° C; Teflon insulation; aluminum mylar tape shield with drain wire; Teflon jacketed overall.
Instrumentation	Instrumentation cable, 300 V minimum, flame retardant single-and multiple-twisted pairs and triads, shielded instrument cable with individually shielded pairs, overall shield, and overall jacket; FRXLPE or FREPR insulation; CSP, PVC, or CPE jacketed overall. (Single pair or triad 16AWG, multi-pair or triad 18AWG).
High Temperature Instrumentation	Same as instrumentation cable above 200°C Teflon insulation and jacket.
High Temperature Fixture Wire	High temperature control and fixture wire, single-conductor control cable; stranded copper; 12 AWG; stranded copper, with normal maximum operating temperature of 200°C; silicone rubber insulation; braided glass jacket.
Lighting & Receptacles	Lighting circuit runs totally enclosed in conduit, NEC Type RHH-RHW-USE with XLPE insulation for use in outdoor or unheated areas.

8.17 GROUNDING

This section covers the furnishing and installation of grounding materials complete as specified herein.

The station grounding system shall be an interconnected continuous network of bare copper conductor and copper-clad ground rods (ground wells maybe used instead of ground rods if dictated by the soil analysis). The system shall be designed to protect plant personnel and equipment from the hazards that can occur during power system faults and lightning strikes. Contractor shall perform ground resistivity testing prior to final design to determine ground analysis parameters. Ground system design will include switchyard and incoming lines in the development of the ground model. The grounding system shall be designed to ANSI/IEEE standard 80, 142, and 665 and NEC Sec. 96A.

The station grounding grid shall be designed for adequate capacity to dissipate heat from ground current under the most severe conditions in areas of high ground fault current concentrations, with grid spacing such that safe voltage gradients are maintained but no grater than 50 feet.. Ground cable shall be sized for a fault duration of 0.5 seconds. The ground system shall be designed to have a resistance to ground of 1 ohms or less. The minimum ground grid conductor size shall be 4/0. Upon completion of ground system installation, perform ground system testing to verify design. Detailed design shall conform to Owner's requirements as covered in Appendix H.

Bare conductors to be installed below grade shall be spaced in a grid pattern. Each junction of the grid or other connections will be bonded together by an exothermal welding process.

If required to maintain step and touch potentials, areas not covered with asphalt shall be covered with a minimum of 4 inches (more if required for step and touch potentials) of suitable crushed rock if not all ready required as part of the site development.

Grounding stingers shall be connected to the building steel, fences, and equipment. Equipment grounds shall conform to the following general guidelines:

1. Grounds shall conform to the NEC and NESC.
2. Major items such as generators, switchgear, secondary unit substations, motor control centers, relay panels, medium voltage motors, and control panels shall have integral ground buses, which shall be connected to the station ground grid.
3. Electronic panels and equipment shall be grounded utilizing an insulated ground wire connected in accordance with the manufacturer's recommendations. In some situations, a separate small grid and ground rod, isolated from the main ground, may be required by the vendor. Where practical, electronics ground loops shall be avoided. Where this is not practical, isolation transformers shall be furnished.
4. Ground conductors will be sized in accordance with the NEC.
5. All single conductor ground wires installed in conduit shall be insulated. Ground conductors included in a multi-conductor power cable may be uninsulated.
6. Grid extended to 4 feet on the inside and outside of the fence line with connections to any access gates. Fence to be grounded at points no greater than 40 feet with ground rods driven at that point. Risers shall be #4 connected to fence fabric.
7. All electrical raceways to be grounded to main grid system.

Remote buildings and outlying areas with electrical equipment shall be grounded by establishing local sub-grade ground grids and equipment grounding systems in a manner similar to the plant area. Remote grids shall be interconnected with the station ground grid to reduce the hazard of transferring large fault potentials to the remote area through interconnecting instrumentation and communication cable shields.

8.17.1 Ground Grid Design

The final conductor sizing, grid configuration, grid depth, grid spacing, and quantities of conductor for the grid is to be determined during detailed design. Ground resistance shall be equal or less than one (1) ohm as confirmed through final ground grid design and testing (as defined above). Site specific soil resistivity studies are required to firm up this design. Specialized ground system software will be utilized for the final design.

Materials

All grounding materials required shall be furnished new and undamaged in accordance with the following requirements:

Rods	$\frac{3}{4}$ inch 10-foot copper-clad standard type. The copper cladding shall be electrolytically bonded to the steel rod or bonded by a molten welding process. Cold rolled copper cladding is not acceptable. Ground rods shall be as manufactured by Blackburn, Weaver, or Owner-approved equal.
Cable	
Bare	Soft drawn copper, Class B stranding, ASTM BB
Insulated	Soft drawn copper, Class B stranding with green colored polyvinyl chloride insulation, UL 83, Type TW, THW, or THHN.
Wire Mesh	Copper-clad, 6 AWG, 6 inch by 6 inch mesh spacing, copper weld or Owner-approved equal.
Bus and Bars	Soft copper, cross section not less than 1/8 inch thick by 1 inch wide, ASTM 8187.
Exothermal I Welds	Molds, cartridges, materials, and accessories as recommended by the manufacturer of the molds for the items to be welded. Cadweld heavy duty or Owner-approved equal. Molds and powder shall be furnished by the same manufacturer.
Flush ground plates	Cadweld B-162 Series, B-164 Series, or Owner-approved equal ground plates with NEMA hole spacing.

All clamps, connectors, bolts, washers, nuts, and other hardware used with the grounding system shall be of copper.

8.18 PLANT SECURITY SYSTEM

Contractor shall install raceway, power cable, and fiber optic cable to each of the plant fence corners, main entrance gate, and contractor turnstile gate. The cables shall be routed to an area designated by Owner in the control room for connection to Owner furnished security system

8.19 ELECTRICAL TESTING

Contractor shall perform detailed testing for all equipment, materials, and systems

furnished under this Contract. Equipment shall be tested in accordance with manufactures instructions and NETA (National Electrical Testing Association - Acceptance Testing Specifications for Electric Power Distribution Equipment and Systems) requirements. In addition to equipment tests, Contractor shall perform functional tests to verify proper operation and interlocks of equipment. Any procedures that may affect the existing plant shall be coordinated with Owner.

Contractor shall prepare detailed written step-by-step procedures for major electrical functional tests such as back-feed and synchronization. Procedures shall include predicted values as well as actual measured values. These procedures shall be submitted to Owner for review and comment. Prior to the start of any of these major tests, all associated parties shall sign-off on the procedure.

Contractor shall prepare a hardbound notebook with copies of the testing reports. In addition CD's shall be prepared with electronic copies of the reports plus any manuals, software, or reference material used in the plant testing. Owner may choose to witness some tests. Prior to start of the testing program coordinate with Owner to identify tests they may witness.

SECTION 9.0

INSTRUMENTATION AND CONTROLS

9.1 GENERAL REQUIREMENTS

This section covers the minimum scope, technical requirements and quality standards for the combine cycle power block instrumentation, control systems, Equipment and interfaces with other plant systems and facilities. The Contractor shall provide all Materials and labor for the engineering, design, procurement, delivery, staging, installation, construction, inspection, factory testing, startup, and commissioning of all instrumentation and controls systems specified herein and necessary for a complete, functional combine cycle power generating facility and in conformance with generally accepted practices for generating facilities. All control and instrumentation design will be performed under the supervision of a Professional Engineer. In addition, all Work shall comply with applicable codes and standards identified in Section 3.0 including all State and local codes, laws, ordinances, rules and regulations.

Provide instrumentation and controls for the plant to keep the number of plant operators to a minimum while providing sufficient monitoring and control capabilities, ensuring continued safe and reliable operation of the plant, and alerting the operators to any abnormal conditions or situations requiring manual intervention in a timely manner. The facility shall be capable of operating at all normal and abnormal conditions, including hot startup with one control room operator and one outside operator. During cold startup, the plant shall be capable of operating with one control room operator and two outside operators.

The integrated control of all plant systems shall be accomplished using Distributed Control Systems (DCS) as described in this Specification.

Provide discrete, independent, and dedicated I/O racks, DCS controllers, and operator interfaces. Controllers and operator interfaces shall be networked together to provide an integrated control system. The controllers, I/O racks, raceways, and conduit shall be completely physically independent of other system. DCS, controller, communication modules, I/O racks shall be partitioned to logical arrangements.

In general, modulating controls shall be backed up by interlocks and/or safety systems which cause pre-planned actions in cases where unsafe conditions develop faster than the modulating controls or the operator can be expected to respond.

Skid mounted Programmable Logic Controllers (PLC) shall be interfaced with the DCS to provide full remote control and monitoring capabilities to the operator. Specific control and monitoring requirements for major systems are described in the Specification sections covering the systems.

All instrumentation and control equipment shall be of proven design and shall be selected to achieve the highest level of plant availability and ease of equipment maintenance. Control and instrumentation provided shall be complete in all respects, requiring no further additions. Standardization of instrumentation and controls hardware shall be observed throughout the Project. All instruments, control valves, PLC controllers, and other control devices of a common nature shall be of the same manufacture, and wherever practical, shall be of identical model. DCS controllers shall be of identical manufacture and model. All electronic field devices shall be Smart, Highway Addressable Remote Transducer (HART) compatible.

All PLC controllers shall be located in air conditioned rooms or enclosures.

In general, local single closed loop control may be utilized for the control of systems that do not require optimization such as, for example, blowdown tank level. Individual sensors with integral or local controls, for example, direct level controllers shall be utilized for these types of loops.

Redundant components, as required by code, shall be installed as completely separate devices with individual sensing taps and individual isolation capability.

All critical sensors for continuous controls and protection shall be redundant. No control I/O signals shall be multiplexed. Indication signals may be multiplexed at the Contractor's option.

Mechanical equipment shall be provided with safety interlocks incorporated into the system controls to prevent damage to the equipment. Mechanical systems shall

incorporate in their control the necessary equipment recommended by the manufacturer to assure that operational Contract conditions, as set forth by Owner, have been complied with.

Mechanical equipment on standby status shall automatically start when system conditions are beyond the parameters set for normal operation. Annunciation shall be provided whenever a "standby" piece of equipment is placed into service.

9.2 DISTRIBUTED CONTROL SYSTEM (DCS)

The DCS shall be designed for automatic supervisory control of the combined cycle generation plant as well as to initiate manual commands and shall provide safe, reliable, and efficient operation of the plant. The Owner's DCS system standard is Emerson Ovation..

The DCS shall include supervisory controls, plant process operation monitoring, plant operating condition indication, and display to advise operating personnel of the current operating status of the plant. During normal operation or in the event of an abnormal plant upset condition(s), the DCS shall enable the operator to take over and manually control the plant.

The DCS shall contain sufficient built-in hardware and software redundancy to include but not limited to redundant control processors, redundant data highway and power supplies with automatic changeover to the standby unit upon detection of a fault of the operating units. The failure of any single element shall not affect the operations or monitoring of the plant.

The DCS shall be utilized to the maximum extent possible for control, monitor, logging, alarm annunciation of plant equipment and the process. Features of the DCS shall include redundancy of controllers, redundancy of power supplies, operator stations, printers, and redundant communications. In addition to control capabilities, the system shall include all features required for historical data recording, data processing, and minor calculations for report generation and billing purposes. Consolidation of files shall be selectable. A minimum of thirty (34) days data storage capacity shall be provided with system to allow for downloading to a CD/DVD drive or DAT-tape drive.

Where process equipment is furnished with its own packaged controls and instruments, these devices shall be interfaced with the DCS as required to provide full data for monitoring, logging, to annunciate, and acknowledge alarm conditions, and to fully communicate DCS commands and responses to and from the packaged controls as required via redundant gateway interfaces.

A control room operator using the DCS shall be capable of supervisory control including starting, stopping, normal operation, and monitoring and acknowledging of alarms for the gas turbine generator(s) and steam turbine without physically needing to go to the GTG or STG control interfaces.

Provide first-out indication, annunciation, alarming, and sequence of event (SOE) monitoring, time stamp to 1 millisecond for each GTG and STG. Provide a GPS time stamping synchronization system or Owner approved equal for the synchronization of all system clocks.

Installation of the DCS shall be in accordance with the manufacturer's recommendations and guidelines. Installation shall take into account noise and grounding considerations. A complete power-up and grounding check shall be performed subsequent to cabinet installation and prior to beginning terminations. The Contractor shall be responsible for the application loading and debugging of all software, and for testing, calibration, startup and commissioning of the DCS and communication links with other plant systems.

Coordination of all electrical and steam generating systems with respect to one another shall be maintained and designed into the DCS controls so that a change in plant load demand shall be translated into a smooth, characterized change in demand to each affected system. The coordinated control shall recognize all limitations exhibited in these systems and shall take appropriate action.

The DCS shall be supplied with all process signals required to perform calculations and comparisons by the operator.

The plant consumption and generation of energy shall be monitored and logged in the DCS. Metering requirements are provided in Section 8. Reports shall be generated for each billing period documenting gross and net generation. These reports will be used to

confirm the utility furnished metering system and may be relied on for billing in the event of a utility metering system malfunction.

Provisions shall be made for the prevention of unauthorized or accidental changes to system configuration. System data logging and recovery capability shall be provided so that control system configuration and database can be quickly restored in the event of an operator error or system failure.

The DCS shall interface with the Owner supplied PI data storage system.

The DCS shall also include the following capabilities for monitoring and controlling electrical systems within the facility, displayed on operator console graphic screen(s):

1. Control, status, and alarm indications of all high voltage circuit breaker on electrical one-line diagram.
2. Analog Input and output signals as indicated on electrical one-line diagram.
3. Control, status, and alarm indications of the emergency AC system transfer switches.
4. Status and alarm indications of uninterruptible power supply (UPS) and DC system.
5. Other analog, status, and alarm indications for complete monitoring of electrical systems and subsystems.

DCS system shall have the following as a minimum:

1. Four operator workstations for plant monitoring and control each equipped with an operator keyboard, mouse, and dual 19" CRT Flat Panel or LCD graphic displays.
2. One dedicated engineering workstation for programming modifications equipped with keyboard, mouse, and dual 19" CRT Flat Panel or LCD graphic displays.
3. Two printers, one for periodic reports and operator logging, the other for an

alarm printer.

4. One color laser printer for hardcopy documentation of system configuration and color graphics.
5. 100 custom interactive P&ID graphics shall be included in the design. In addition to these displays, all control loops, indicator, and alarms will be shown on group displays depicting H/A stations and push button stations.

Provide the capability to allow all graphics and controls interface to be monitored and manipulated from any of the operator interfaces and the engineering workstation.

All software and operating systems provided shall be manufacturer's latest offering and shall comply with the design requirements, features, and capabilities specified herein.

All control room furniture and consoles provided for the Project shall be of identical manufacture and configuration. Consoles shall be provided for the operator stations, engineering station, GTG and STG Remote HMI's, CEMS stations, 5 printers, and trip panel containing GTG, STG, HRSG MFT Trip pushbuttons. The existing Block 1 combined cycle plant control room shall be expanded by Owner to incorporate the new Block 2 combined cycle plant consoles, and plant control workstations. A layout for existing Block 1 Central Control Room detailing Block 2 layout is attached in Appendix C.

9.3 DCS CONTROLLERS AND I/O

DCS Controllers shall be loaded to no more than 60-percent upon completion of Factory Acceptance Testing and 75-percent upon completion of commissioning. Controller cabinets shall be located throughout the plant, as required, to enhance reliability and to reduce wiring requirements.

The DCS shall be sized such that there shall be 20-percent spare's of each I/O type at each location at time of shipment to the site and 10-percent spares of each I/O type at each location at Substantial Completion, as a minimum. In addition, cabinets will be furnished with at least 10-percent spare card slots in every card cage and 20-percent extra space in each cabinet for future use.

The system will be capable of scanning, processing and storing any inputs and outputs

at the rate of at least four times per second and at 1 millisecond for SOE points. Peer-to-peer communications between controllers will communicate all points at the rate of once per second. Actual scan times will meet the hardware requirements for the controller loop processing time. Overall system scan rate shall not exceed 250 milliseconds.

To permit removal of I/O modules without removing field wiring, all I/O field terminations shall be terminated on separate field termination blocks in I/O cabinets.

Analog input signals to the system will be isolated and either current limited or fused from the internal circuitry so that shorting, grounding or opening the circuit at the transmitting Equipment will not affect control system performance. Analog inputs shall not exceed 8 per card. The system shall provide quality checks for all analog inputs. Data will be automatically tagged as bad on all displays or logs if the input value is out of range. System accuracy shall be 0.1-percent of calibrated range, (excluding transmitters).

Analog output signals from the system will be isolated and either current limited or fused from the internal circuitry so that shorting, grounding or opening the circuit at the receiving Equipment will not affect control system performance. Analog outputs will not exceed eight per card. System accuracy will be less than 0.5-percent of output signal range (excluding final element).

Digital (contact) outputs will be individually fused in the control system. Digital outputs will not exceed 16 per card. Interposing relays will be used for all applications where the current and/or voltage requirements exceed the capability of the DCS outputs. The system will be capable of assigning each digital output as momentary or maintained. Momentary outputs will be present for at least 100 milliseconds but not more than two seconds. The system will be capable of providing normally open and normally closed contact outputs.

Digital (contact) inputs will be individually current limited. Digital inputs will not exceed 16 per card. Contact inputs will be scanned at the controller level for status change. Normal state for a contact will be definable as either open or closed. In general, digital inputs shall be failsafe or closed for normal state. The system software will have the ability to apply digital filtering or time delay to all contact inputs.

The DCS shall be capable of resolving at least 100 inputs for Sequence of Events (SOE) monitoring at a resolution of 1 millisecond. Control shall provide a preliminary SOE list for Owner review and approval. System shall be able to assign any digital point in the control system for SOE service. Grouping of these points is acceptable, but the points or groups may be distributed in all I/O locations including remote I/O. The provided GPS time stamping synchronization system shall be used for the synchronization of all system clocks and for the SOE time stamp.

The processing for thermocouple and RTD inputs is the same as that described for analog inputs above. The system will also check for open thermocouple and provide alarm. Thermocouple readings will be linearized.

9.4 INTERFACES AND NETWORKS

The DCS shall be interfaced to a number of systems throughout the plant and remotely to include, but not limited to the following:

1. GTG
2. STG
3. HRSG Duct Burner PLC's
4. RTU for Dispatch Control
5. CEMS
6. Plant Skids/systems implementing PLC's

The DCS control system components shall incorporate a 100mbps Ethernet communications network. The network shall be provided for control and monitoring from the operator, engineering servers and client workstations.

Data communication link interfaces shall be provided with watchdog timers and communications alarms.

All communications cabling running exterior to plant buildings shall utilize multimode fiber optic cabling with fiber patch panels, fiber to Ethernet media converters as specified in Section 8.0.

9.5 REMOTE TERMINAL UNIT (RTU) DISPATCH

An RTU to implement Dispatch Automatic Generation Control (AGC) will be furnished and installed in the switchyard control building by others. The Contractor will provide a fiber optic connection from the switchyard RTU located in the switchyard control building to the plant DCS. Provide all facilities required for RTU communications between the power plant and Switchyard control building. Any I/O points required at RTU but not available in the DCS shall be hardwired to the RTU. Facilities shall include but not be limited to, ductbank, fiber, wiring, programming, and interface equipment. The Contractor shall provide all required Fiber Patch Panels at the substation and control room and/or other location to allow for the complete termination of all fibers into and out of each location. The Contractor shall work with the Owner Dispatch Center and personnel and to test and commission the DCS to Dispatch link for control, monitoring and alarming functions as specified in Section 8.

9.6 DCS FACTORY ACCEPTANCE TEST (FAT)

The Contractor and DCS manufacturer shall completely configure, load, and debug the DCS control system components and database at the factory or Contractor's facilities prior to FAT. A hardcopy printout and electronic copy of the I/O database, graphic screens, logic diagrams and detailed hardware configuration and FAT plan itemizing FAT activities shall be supplied to the Owner in advance for review and comment prior to finalization of system configuration and FAT. FAT plan and schedule shall be agreed to by Contractor and Owner early in the Project cycle. The DCS manufacturer shall provide 3 weeks for the FAT of the hardware, logic and software design and data communication interfaces. The FAT Logic shall be verified by simulation. Data communication links to the GTG, STG, and HRSG Duct Burner PLC shall be verified using a test simulator per the manufacturer's recommended practices. Owner shall witness FAT. DCS manufacturer shall provide problem or variance report sheets to document any and all problems encountered with hardware, software, graphic screens or control logic implementation. All problems found during the FAT shall be reconciled prior to shipment to the field. Owner reserves the right to require additional FAT, at Contractor's and/or DCS manufacturer's expense, if original testing proves the system design to be incomplete or substantial revisions are required.

9.7 HARD PANEL CONTROL BOARD

Hardwired, redundant, emergency trip, mushroom-style push buttons one pair for each GTG, STG, and HRSG MFT one for the entire block, and one for closing the emergency fuel gas shutoff for Block 2 shall be provided as a part of the emergency shutdown protection panel as required by the system per Section 5.

9.8 INSTRUMENTATION AND CONTROL DEVICES

9.8.1 General

Signals for analog control system inputs and outputs shall be provided from process transmitters at 4-20 mA signal level, or direct-wired RTDs and thermocouples. Pneumatic signals shall be 3-15 psi.

Instrument primary sensing devices shall be nominally ranged at 150 percent of the systems normal operating pressures and temperatures.

Instrument calibration shall be verified by Contractor and documented for submittal to Owner.

Instrumentation and sensing lines shall be freeze protected where appropriate for instrumentation supplied by Contractor and by equipment manufacturer as required.

Gauges and indicators, including position indicators on valves, shall be installed to be visible from normal operating platforms or accessways without the need for ladders, mirrors, or other devices. All termination lugs shall be applied with a ratchet type crimping tool to insure an equal pressure connection between lug and signal cable core.

9.8.2 Thermocouples and Resistance Temperature Detectors

Temperature measurement shall in most cases be performed using thermocouples. Thermocouples and extension wire shall comply with the standard limits of error according to ANSI MC96.1-1975 and shall be Type E.

Resistance temperature detectors (RTDs) of the three-wire platinum type shall be used in certain cases such as motor winding temperature measurements. The nominal

resistance of the platinum detectors shall be 100 ohms at 0°C. All resistance temperature detectors shall be metal sheathed, and ceramic packed.

Thermocouples and RTDs shall have stainless steel sheathed elements and spring-loaded to provide good thermal contact with the thermowell. All connection heads shall be weatherproof equivalent to NEMA 4, with chain-connected screwed covers, and supported from the well by lagging extension long enough to clear the head of the temperature element above the process pipe lagging.

9.8.3 Thermowells

Temperature sensors shall be equipped with thermowells made of one piece, solid bored Type 316 stainless steel (or higher alloy if required for the application) of step-less tapered design. Maximum bore internal diameter shall be 0.385 inch.

Test wells shall be provided on main steam, feedwater, condensate, and other piping as required to meet ASME test requirements. Test wells shall be provided with screw cap and chain.

9.8.4 Flow Elements

Flow elements shall be provided in accordance with appropriate applications and in accordance with requirements contained in Section 5. Weld-in type Factory Certified Flow Nozzles shall be used for Main Steam, Hot Reheat and Cold Reheat flow measurements. Flow Nozzle shall be provided with two (2) sets of pipe wall pressure taps. All FEs required for performance testing shall be PTC6 certified to include but not limited to: HP and IP Feedwater, LP Steam, Condensate, and Cold Reheat.

9.8.5 Transmitters

Transmitters shall be used to provide the required 4-20 mA DC signals to the DCS. Transmitters shall be of the smart electronic two-wire type, HART compatible and capable of driving a load of at least 500 ohms with non-interacting zero and span adjustments and remote recalibration features.

9.8.5.1 Static Pressure and Differential Pressure Transmitters

Differential pressure transmitters shall be HART compatible with transmitter sensor specified to withstand 150 percent of design pressure. DP transmitters shall be provided

with remote seals and filled capillaries where required, static pressure protection limit and any other applicable options required to accommodate specific applications.

9.8.5.2 Level Transmitters

Sensing elements for level transmitters shall be as follows:

1. Gauge pressure transmitters for vessels exposed to atmospheric pressure.
2. Enclosed, pressurized vessel level shall be measured using radar, ultrasonic, guided wave radar or Differential Pressure transmitters with filled capillaries and remote seals.
3. Differential Pressure element with constant head chamber for high pressure and temperature applications where installation of float cage becomes impractical (level transmitters of this type are the same as differential pressure transmitters).

9.8.5.3 Flow Transmitters

Flow transmitters, in general, shall be differential pressure types. Square root extraction shall generally be performed electronically in the control system.

9.8.6 Gas Meters

Contractor shall tie into the existing gas metering station. A check meter shall also be provided on the main gas supply to Block 2. Meters used for fuel gas flow measurement shall be complete with temperature and pressure compensation capability using design pressure and temperature as its base conditions. Total gas flow shall be indicated locally, and gas flow rate shall be transmitted to, and monitored and totalized in, the DCS. Flow meters shall meet the requirement of the EPA and Currant Creek Air Quality Permit. Manufacturer's calibration certificate shall be provided that shows that flow meter meets the accuracy requirements of the EPA and Currant Creek Air Quality Permit.

9.8.7 Temperature, Pressure, Level, and Flow Switches

Temperature, pressure level, and flow switches shall generally have two Form C contacts for each actuation point and shall be equipped with screw type terminal connections on a terminal block for field wiring. Switch set point and deadband shall be

adjustable with a calibrated scale. Contacts shall be snap acting type. Switch enclosures shall be NEMA 4 for non-hazardous locations, and NEMA 7 or 9 for hazardous locations. All termination lugs shall be applied with a ratchet type crimping tool to insure an equal pressure connection between lug and signal cable core.

9.8.8 Local Indicators

9.8.8.1 Thermometers

Thermometers shall be the bimetallic adjustable, every-angle types with minimum 4-½ inch dials. Where view is obstructed or unavailable, thermometers shall be provided for remote mounting including filled capillaries..

9.8.8.2 Pressure Gauges

Pressure gauges shall be the bourdon tube type with solid front cases with blowout back, 4-½ inch dials, stainless steel movements and nylon bearings. Gauges shall have ½-inch NPT bottom connections. Gauges shall be provided with pigtail siphons for steam service, snubbers for pulsating flow, and diaphragm seals for corrosive or severe service. Gauges located on process lines exposed to ambient temperature shall be freeze protected.

9.8.8.3 Local Level Indicators (Gauge Glasses)

Tubular gauge glasses shall be used for high-pressure applications. Mica shields shall be used with transparent gauges on steam/condensate service. All gauge glasses shall be equipped with gauge valves, including a safety ball check.

9.8.9 Control Valves

Control valves shall be used in modulating service throughout various processes within the facility and as specified in Section 5. Globe valves shall be used extensively in water, steam, gas, and oil service with butterfly and ball valves used in limited applications, typically low pressure and temperature water service.

Pressure retaining component and valve trim materials shall be selected based on process conditions such as type of fluid, static and differential pressures, and temperature. In general, control valves in water and steam service shall be provided with hardened stainless steel trim.

Modulating control valves shall be sized to pass design flow at 60 to 80% of valve capacity. Multiple service conditions should be specified when a control valve is expected to operate over a wide range of travel, i.e., feedwater flow and drum level control valves. When the calculated Cv is less than the manufacturer's recommended minimum Cv, two valves with split range control shall be provided, unless otherwise approved by Owner.

Minimum control valve body size shall be not less than 50% of the upstream pipe size. When a calculated Cv requires a smaller valve, reduced trim shall be used in order to maintain the body size requirement. Reduced trim shall not be less than 40% of valve capacity.

Pneumatic actuators of the diaphragm or piston/cylinder type shall be Smart, Hart compatible, with the ability to provide position feedback and diagnostic information on each valve. All critical valves shall be equipped with hardwired position feedback modules. Careful consideration should be given to the fail-safe position of control valves. Where practicable, actuators with integral springs shall be specified. All control valves shall be capable of operating with a 60 psig air header pressure.

In general, all control valves shall have ANSI class IV leakage ratings. Valve failure philosophy shall be developed with Owner participation.

Control valves shall be designed to operate from a control signal range of 3 to 15 psi.

Each control valve shall be provided with accessories such as handwheels, filter regulators, solenoid pilot valves, limit switches, and position indicators as applicable.

9.8.10 Instrument Racks

Where possible, field instruments other than local indicators shall be grouped together on instrument racks. Maximum tubing run from the sensing point to the rack shall be 50 feet, unless approved otherwise by Owner. Interior instrument racks shall be open structures with frames constructed of angle or structural tubing. The frames shall be reinforced as required to provide adequate support for instruments and equipment. Equipment supports shall be horizontal members, which provide a place for the attachment of mounting brackets and clamps for piping and tubing.

Instruments exposed to ambient temperatures shall be housed in heated instrument enclosures with heat traced impulse lines with integral tubing bundle. Integral tubing bundle shall be O'Brein or Owner approved equal. Heated enclosures shall be diagonal, clam-shell style to provide easy access to process instruments from the front, top or either side. No flexible insulation (soft-case) is acceptable. Enclosures shall have a maximum of three (3) instruments each and shall be large enough to house all required blowdown valves inside enclosure. Heat trace system shall be designed to activate enclosure heaters when ambient temperature is below 40 degrees Fahrenheit. Heat trace panel requirements are defined in Section 8.

9.8.11 Tubing Systems

Instrument, control, and sampling tubing systems shall be designed, fabricated, and tested in accordance with ANSI ISA RP 7.1.

Primary process instrument and sampling tubing for steam and water systems shall be ASME SA213 grade TP316H SS 3/8 inch .049 standard wall or 1/2 inch .065 standard wall, respectively (Note: On high pressure, high temperature applications, tubing shall be 316H minimum wall per ANSI B31.1 specifications).

Fittings shall be manufactured of the same material as the tubing, wherever practical. Where not practical, fittings shall be manufactured of a harder material than the tubing and at minimum of Rockwell 80B.

Pressure type instruments shall have associated isolation and test valves or combination two-valve isolation/test manifolds. Differential pressure type instruments shall have associated pairs of isolation and test valves plus an equalizing valve or combination three-valve isolation/test/equalizing manifolds.

Blowdown valves shall be provided for each remote device as required. Tandem blowdown valves shall be provided on high pressure, high temperature applications (pressure greater than 600 PSIG and/or temperature greater than 450 degrees Fahrenheit). Blowdown valves are not required for vacuum, gas, or dry air service.

Sample tubing systems carrying high temperature samples shall be insulated or guarded in areas which require personnel protection.

9.9 CONTROL SYSTEM LOOP COMPONENT DESIGN

The major plant systems to be controlled and monitored are described and presented in Section 5. They include the following:

1. Gas Turbine/Generator Systems.
2. Steam Turbine/Generator Systems.
3. Heat Recovery Steam Generator Systems.
4. Feedwater Systems.
5. Air Cooled Condenser (ACC) System
6. Water Treatment System
7. Fuel Gas Metering and Conditioning System.
8. Plant systems to include tie-in to Block 1 Raw Water System.
9. Plant Monitoring System.

9.9.1 Gas Turbine Generator (GTG)

Each gas turbine generator is supplied with a dedicated microprocessor based control system which contains the unit metering, protection, and control switches. The GTG control system provides control functions including: fuel, air and emissions control; sequencing of turbine fuel and auxiliaries for startup, shutdown and cool down; monitoring of turbine control and auxiliary functions; protection against unsafe and adverse operating conditions. Gas turbine controls shall be designed to minimize unnecessary trips, nuisance alarms, and false starts. Runbacks, rather than trips, shall be utilized whenever possible. The GTG control system shall provide for the automatic and semi-automatic starting, automatic and manual synchronizing, loading, and shutting down of the turbine. Comprehensive supervisory systems and equipment for monitoring operational status, alarms and automatic protection shall be provided for the safe, reliable remote operation of the machine. The GTG and GTG control system is described in Section 5 of these Specifications. Gas turbine controls shall be designed to minimize unnecessary trips, nuisance alarms, and false starts. Runbacks, rather than trips, shall be utilized whenever possible.

The DCS shall be implemented to provide supervisory control, monitoring, alarming and historical functions for each GTG and shall interface to each GTG control system through hardwired and data link interfaces. The DCS interface to each GTG control system shall be in accordance with the turbine manufacturer's recommended configuration. The DCS, through a combination of hardwired and data link interfaces, shall be able to perform all actions necessary to start and stop the unit, raise and lower load, monitor status, log operating data, and annunciate and acknowledge alarms. Critical control functions, status and alarms for essential gas turbine operation will be hardwired to the DCS control system. Remaining control functions, status, and alarms shall be interfaced with each GTG control system through a high speed 100 Mbps, fiber data link per manufacturer's recommended configuration. The link will provide all data on the manufacturer's standard interface list, as required. Final determination of I/O will be subject to Owner approval. Key GTG system control, alarm, and status graphics shall be integrated with the DCS to provide the identified supervisory control. A common GTG Remote HMI shall be provided in the main control room for detailed controlling, alarming, and monitoring of the Gas Turbine system. The main control room shall serve as the primary operator interface.

All critical control trips and interlocks shall be hardwired between the DCS and the GTG control system. Remote manual tripping of the GTG shall be possible using the auxiliary console-mounted, hard-wired emergency stop pushbuttons located in the control room.

The Contractor shall submit with Bid a conceptual Control System Architecture diagram outlining the anticipated configuration for Owner review. This diagram shall define what control and monitoring functions will be provided at the centralized control room, and at various locations throughout the system, location of each I/O drop, number of processors at each location, approximate number and type of I/O at each location, PLC drops, communications protocol, and other applicable information.

9.9.2 Steam Turbine Generator

The steam turbine generator will be provided with a dedicated microprocessor based control system that includes an electronic governor for speed and load control with all standard interlocks required for start-up, loading, shutdown, and tripping of the turbine-generator. The steam turbine speed control and inlet pressure control will be done

through the governor. Comprehensive supervisory systems and equipment for monitoring operational status, alarms and automatic protection shall be provided for the safe, reliable remote operation of the machine. The STG and STG control system is described in Section 5 of these Specifications.

The DCS shall provide supervisory control, monitoring and alarming for the STG and shall interface to the STG control system and governor through hardwired and data link interfaces. The DCS interfaces to the STG control system shall be in accordance with the turbine manufacturer's recommended configuration. The DCS, through a combination of hardwired and data link interfaces, shall be able to perform all actions necessary to start and stop the unit, raise and lower load, monitor status, log operating data, and annunciate and acknowledge alarms. Critical control functions, status and alarms for essential steam turbine operation will be hardwired to the DCS control system. Remaining control functions, status, and alarms shall be interfaced with each STG control systems through a high speed 100 Mbps fiber data link per manufacturer's recommended configuration. The link will provide all data on the manufacturer's standard interface list, as required. Final determination of I/O will be subject to Owner approval. Key STG system control, alarm, and status graphics shall be integrated with the DCS to provide the identified supervisory control. A STG Remote HMI shall be provided in the main control room for detailed controlling, alarming, and monitoring of the steam turbine system. The main control room shall serve as the primary operator interface.

All critical control trips and interlocks shall be hardwired between the DCS and the STG control system. Remote manual tripping of the STG shall be possible using the auxiliary console-mounted, hard-wired pushbuttons located in the control room

9.9.3 Heat Recovery Steam Generator (HRSG)

Control of the HRSG shall consist of the following loops under control of the DCS to safely and efficiently maintain steam header pressure and feedwater to match turbine-generator requirements during start-up, normal operation, upsets, and shutdown. Duplicate controls shall be supplied for each HRSG, as required. Consult Section 5 for further requirements.

Control of each HRSG shall include the following subsystems:

9.9.3.1 HRSG Drum Level Control System

The HRSG drum level control system shall be conventional three-element control using main steam flow as the feed-forward signal, drum level, and feedwater flow as the feedback signals. Based on demand, the system controls the feedwater control valve to adjust feedwater flow to the HRSG. The system will be designed to operate on single-element control using drum level only during start-up. Transfer from single-element to three-element and back to single-element shall be automatic based on steam flow.

9.9.3.2 Duct Burner Safety System

The duct burner control system shall be fully integrated with the plant DCS. The duct burner safety system shall be a self-contained PLC and shall be designed to safely shut down the HRSG auxiliary burner system on abnormal and emergency conditions. The system shall be interlocked to shut down the fuel gas to the HRSG as recommended by the HRSG manufacturer. The duct burner safety system shall comply with NFPA 8506 and the NEC code. The duct burner safety system shall incorporate hardwired and softlink status, alarms, controls signal for control and monitor from the DCS.

9.9.3.3 Ammonia Injection Control System

The ammonia injection control system shall be designed to control stack emissions to meet permit requirements.

9.9.3.4 Steam Temperature Control System

The purpose of this system is to maintain the final superheater and reheater outlet temperatures at a set value with minimum fluctuation. This shall be a single station, cascade-type control system in which the final superheater and reheater outlet control units serve as the master or primary control units, and the desuperheater outlet control units serve as the slave or secondary control units.

9.9.3.5 LP Drum Level Control System

The LP Drum levels shall be controlled by the DCS. Level switches shall be provided to alarm high and low levels and to trip the feedwater pumps on low-low level.

9.9.4 Feedwater System

Feedwater systems will be comprised of the following subsystems:

9.9.4.1 Condensate Receiver Tank Level Control

The level shall be controlled from the DCS. Cycle water make-up flow shall be regulated through a control valve to maintain condensate tank level. If the level is low, make-up will be admitted from the demineralized water storage tank. If the level is high, a fraction of the condensate flow will be routed to the demineralized water storage tank to prevent condenser flooding. Level switches shall be provided to alarm high and low levels. Pump run indicators shall be provided to alarm pump cutout. Condensate tank shall also be provided with local level indication.

9.9.4.2 Boiler Feed Pump Minimum Flow Control

Feedwater pump minimum flow control consisting of a recirculation valve which circulates water back to the LP drum during periods of low HRSG feedwater demand shall be provided. This may be in the form of a flow control valve.

9.9.4.3 Boiler Feed Pump Existing Vibration Monitoring

BFP shall be equipped with Bentley Nevada Vibration Monitoring Control monitoring systems. This system shall be tie to Block 1 main Bentley Nevada Vibration Monitoring System.

9.9.5 Air Cooled Condenser (ACC) System

The ACC system controls shall be implemented through the DCS. The ACC system components, performance and requirements are identified in Section 5. ACC fans shall be controlled automatically from the DCS as required to maintain the steam turbine condenser backpressure at operator selected values associated with acceptable steam quality in the steam turbine and maximum plant net output. In addition, the implemented controls shall protect system from freezing, include no sub-cooling, and minimize parasitic power consumption.

9.9.6 Water Treatment Systems

The water treatment systems shall be prepackaged units with self-contained PLC controls. All data from the water sample panels shall be provided for control, monitoring and alarming in the DCS.

9.9.7 Fuel Gas Metering and Conditioning System

The Fuel Gas Metering and conditioning system shall be prepackaged units with self-

contained PLC controls. Data from this system shall be provided via communication link and/or hardwired interface for monitoring and alarming in the DCS. See Section 5 for system requirements.

9.9.8 Plant Systems – Raw Water

Block 1 Raw Water Supply System shall be modified to support the new Block 2 combine cycle plant. Block 1 Raw Water System includes two (2) existing Well pumps, and an existing Raw Water Storage Tank. A second Raw Water Storage Tank shall be added for Block 2. Modification of existing Block 1 Raw water system and controls may be required to enable Block 2 to control existing well water pumps, and to monitor the level in Block 1 Raw Water Tank.

9.9.9 Plant Monitoring System

Plant parameters shall be monitored and indicated, alarmed and/or recorded in the DCS to facilitate the plant operator with control of the plant. The gas turbine and steam turbines shall be interfaced to the DCS for monitoring, trending, and control from the DCS. All local controllers shall be interfaced with the DCS for monitoring, trending, and control from the DCS.

9.10 HISTORICAL DATA STORAGE AND RETRIEVAL

Provide historical trending of all DCS data points including data provided from the combustion turbine and steam turbine control systems. Provide enough on-line memory to support a 34-day recall of all data points taken at the following periods:

Temperature:	5 min.
Levels:	1 min.
Pressures:	1 min.
Flows:	15 sec.

Provide a CD/DVD writer in the control system to facilitate downloading and archiving of the trended data.

9.11 CONTINUOUS EMISSIONS MONITORING SYSTEMS

Dedicated extractive continuous emissions monitoring systems (CEMS) complete in all respects including analyzers, sample extraction system, sample lines, flue gas flow

equipment, data acquisition system, controllers, printer, monitor display, keyboard, mouse, software, controls, modem link, and other system specific accessories shall be installed in the HRSG stacks to measure the NO_x, CO, and O₂ concentrations at the HRSG stacks. The CEMS shall be housed in a shelter located at the base of the HRSG stacks.

Additional NO_x monitors shall be installed in HRSG upstream of SCR catalyst to monitor ammonia injection and CTG emission rates.

Each CEMS shall meet all the requirements of the plant air quality permit and state and local regulations. The CEMS shall be designed to comply to the requirements of the Environmental Protection Agency as stated in 40 CFR Part 60 "Standards of Performance for New Stationary Sources," specifically Paragraph 40 CFR 60 Subpart GG; 40 CFR Part 60.13; 40 CFR 50 Appendices B and F; and 40 CFR Part 75.

Each CEMS shall monitor the operation of each unit by obtaining a reading of NO_x, CO, and O₂ concentrations at least once every 15 minutes for each unit for each sample point, and shall display the following air pollution control parameters:

1. Exhaust unit flow.
2. NO_x, CO, and O₂ in ppmv at actual stack conditions.
3. NO_x in ppmv and lb/hr upstream of SCR catalyst.
4. NO_x, CO, and O₂ in ppmv corrected to 15% oxygen on a dry basis.
5. NO_x and CO in lb/hr.
6. Temperature at the SCR.
7. NO_x at SCR inlet.
8. Fuel consumption.

Each CEMS shall be designed with a stand-alone personal computer, with an emissions software package which includes emissions warning, archiving, and report generation, as required under CFR 40, Part 60, Appendix F; 40 CFR PART 75; and the air quality

permit. Daily calibration error test can not exceed 5.0% of span value (or exceed 10 ppm). Linearity – No quarterly linearity test required. RATA shall be ≤ 0.015 lb/MMBtu mean difference.

The CEMS personal computers shall be networked together with a supervisory station located in the control room. The DCS/PI Data Historian shall interface with the CEMS supervisory station through a communication link. The link shall provide up to 50 analog data points and 75 digital data points.

Equipment standards shall be per PacifiCorp CEMS Currant Creek Requirements document to be provided at Contractors request. The dedicated extractive CEMS shall be supplied with the following analyzers and systems:

1. NOx Analyzer shall be Thermo-Fisher Scientific 42i-LS Dual Range (Low 0 – 5 ppm, High 0 – 200 ppm) Note: Readings obtained during typical unit operation shall be kept between 20.0 and 80.0 percent of full-scale range of the instrument (1 - 4 ppm).
2. CO Analyzer shall be Thermo-Fisher Scientific 48i CO Dual Range (Low 0 - 10 ppm, High 0 – 150 ppm).
3. Oxygen Analyzer shall be Servomex 1440 with Range: 0 – 25%.
4. Extractive Sample Probe shall be M&C SP-2020 extractive or Universal 270S w/ heated stack filter.
5. Sample Line will be heat traced with a temperature controller capable of maintaining 240 degrees F at minus 20 degrees F ambient. Each sample line will consist of three (3) 3/8" Teflon tubes (sample line, blow back, spare) and two (2) 1/4" Teflon Tubes (calibration gas, spare).
6. Sample Conditioner shall be M&C or Universal and shall utilize the peltier effect for condensing moisture from the gas sample. The condensate will be removed with a Masterflex dual head peristaltic pump. The sample system must include an inline 2.0 micron particulate filter and a moisture conductivity sensor.
7. Contractor provided Fuel Flow meter shall be Yokogawa vortex flowmeter.

The flowmeter must be certified for Part 75 using the applicable procedure found in 40 CFR Part 75, Appendix D, section 2.1.5. The certification results must accompany the flowmeter.

9.12 ONLINE PERFORMANCE MONITORING SYSTEM

Contractor shall supply a General Physics Eta-Pro Performance Monitoring System including software license and all equipment and services required for software configuration, installation, testing, and training to provide a fully functional performance monitoring system. The system will provide plant and component performance at actual operating conditions compared to expected plant and component performance at the operating conditions. Expected plant and component performance shall be adjusted to levels demonstrated in the plant performance tests.

The system shall include the following:

1. Gas Turbine Performance. Actual and expected performance of each GTG based upon OEM correction curves for heat rate, heat consumption, exhaust energy, exhaust temperature, compressor pressure ratio and efficiency. Performance shall be calculated based upon ambient conditions and selected load. Effects of evaporative inlet cooling shall be included in the calculations.
2. HRSG Performance. Actual and expected performance of each section of the HRSG to include duct burner duty, efficiency, pinch points, steam flows and temperatures.
3. Steam Turbine Performance. Actual and expected steam turbine performance of the HP, IP, and LP section at actual steam and backpressure conditions.
4. Air Cooled Condenser Performance. Actual and expected ACC performance at actual ambient temperature and wind conditions and load conditions including approach, duty, and STG backpressure.
5. Pump Performance for CCW Pumps, Boiler Feed Pumps, and Condensate Pumps. Actual and expected pump performance at actual operating conditions including efficiency, head and power consumption. Boiler feed pump calculations shall include consideration of variable speed drive.

6. Contractor shall provide software customization including screens, reports, and performance calculations as reviewed and approved by Owner. Reports shall be in Excel spreadsheet format.

Contractor shall provide a plant weather station to provide necessary ambient inputs such as wet bulb temperature, relative humidity, barometric pressure, and wind speed and direction.

The system shall interface with Owner provided PI Historian. Contractor shall provide all interfaces required for the PI system as necessary for a complete and operable system.

The system shall be designed to allow expansion to an Owner supplied LAN serving other PCs at a later date.

SECTION 10.0

TRAINING PROGRAM

The purpose of the training program is to provide specific information about the power plant to qualified operator trainees. The overall intent is to provide a comprehensive program that will increase the competence level of the plant operating personnel to ensure that the plant can be safely operated.

The training shall consist of basic theory, as well as specific technical training on major equipment and systems functions. The basic theory shall provide an effective base for those who have had no formal training and a refresher for those who have experience. This shall prepare everyone to a common level for specific technical training on major equipment and systems.

The training program shall include, at a minimum:

1. Classroom instruction with active instructor-trainee interaction and utilize a full range of training materials and professionally produced training tapes.
2. In-plant, hands-on training by various instructors and major equipment suppliers.
3. Exercises to familiarize trainees with all the different systems in the plant.

Training shall include use of the Plant Manual.

Skill testing and progress monitoring shall be used throughout the training program to gauge the effectiveness of the training and the knowledge of the trainees. All training shall be reviewed with Owner on an ongoing basis.

Training program shall include a minimum of 100 hours of overall plant training by Contractor. Training program shall also include major equipment training, both classroom and hands-on, to be conducted by the equipment vendors. Vendor training for equipment purchased by Owner shall be coordinated and managed by Contractor. As a minimum, vendor training shall be provided for the following equipment:

1. Gas turbine generators.

2. Steam turbine generator.
3. Transformers.
4. Heat recovery steam generators including duct burners and SCR ammonia injection systems.
5. Boiler feedwater pumps.
6. Distributed control system.
7. Continuous emissions monitoring system.
8. Air Cooled Condenser System.

As part of the training program the contractor shall include operator trainees in commissioning of the DCS. The Contractor shall maintain a DCS technician for follow-on training on site for 6 months after acceptance. DCS technician selection shall be subject to _____ Owner's _____ approval.

SECTION 11.0

START-UP, INITIAL OPERATION AND PERFORMANCE TESTING

11.1 GENERAL

11.1.1 SUMMARY:

1. Contractor shall prepare all Equipment and systems installed under this Contract for initial operation in accordance with the manufacturer's instructions, these Specifications. Contractor shall use latest technology to carry out the plant start-up, initial operation, and performance testing process in the shortest time possible.
2. Contractor shall provide all labor and materials to perform cleaning, flushing, sterilization, steam line blowdown, operational checks and adjustments, and preparation for initial operation.
3. Contractor shall cooperate with Owner and manufacturer's service personnel during the start-up period.
4. Contractor shall provide all supervision and labor as required for initial operation of all piping systems, equipment and appurtenances installed under this Contract until the Project is turned over to the Owner.
5. Owner shall provide to Contractor all reasonable and necessary support during the commissioning and startup of the Plant.
6. Owner shall provides operations and maintenance staff personnel to participate in the commissioning activities. This support shall be provided during normal working hours or other times as may be requested by Contrator with advance notice.
7. General Requirements:
 - A. Perform specified inspections and tests and report all deficiencies in Equipment and Materials to Owner immediately upon becoming aware of them. Where applicable, perform Work under the direction of equipment manufacturer's field service representatives.
 - B. Contractor shall be responsible for any damage to Equipment or Material due to improper test procedures or test apparatus handling, and replace or restore to original condition at the Owner's option, any damaged Equipment or Material.

- C. Furnish miscellaneous hand tools, ladders, or scaffolding, as required, to allow access to equipment, boxes, cabinets, or devices.
- D. Furnish updated P&ID's prior to start of commissioning.
- E. Certain inspections and tests specified to be performed by this Contract may also be performed by others. This overlapping and duplication is necessary and intentional. Contractor will be notified of tests by others prior to test to assure proper safety procedures are followed.
- F. Owner will review and approve the testing schedule of all plant testing and inspections. Contractor shall cooperate and work closely with Owner during all phases of construction, especially with respect to the following:
 - G. Sequence and priorities of construction and start-up.
 - H. Testing and testing methods.
 - I. Equipment checkout and procedures.
 - J. Equipment start-up.
 - K. Testing records.
 - L. Tagging procedures for personnel and equipment safety.

11.1.2 QUALITY ASSURANCE:

1. Perform all work to meet the quality specified hereinafter and the quality assurance requirements of the Equipment manufacturers, including, but not limited to, the following standards:
 - American National Standards Institute (ANSI).
 - American Society of Mechanical Engineers (ASME).

11.1.3 SUBMITTALS:

1. Submit as specified in SECTION 4 of this Specification.
2. Submittals required shall include the following:
 - A. Contractor shall submit a detailed flushing and cleaning procedure 90 days prior to performance of the activity. This will include, but not be limited to, calculations, demineralized water source, disposal procedure, pipe routings, auxiliary requirements, equipment source, schedules, etc.
 - B. Contractor shall submit a detailed steam blow procedure 90 days prior to performance of the activity. This shall include, but not be limited to, calculations, pipe routings, steam requirements, support designs, schedules, etc.
 - C. Contractor shall submit a detailed gas blow procedure 90 days prior to

performance of the activity. This shall include, but not be limited to, calculations, pipe routings, support designs, schedules, etc.

- D. Contractor shall submit a detailed acceptance and performance test procedure as part of the Turnover Package 90 days prior to starting the testing.

11.1.4 ACCEPTANCE AND PERFORMANCE TESTS:

1. After a period of initial operation, a performance test will be conducted by Contractor on the complete power plant.
2. If operation and performance of the power plant is unsatisfactory due to any deficiency in Contractor's Work, Contractor shall make repairs and redo his Work to obtain satisfactory operation and performance.

11.1.5 EXECUTION

1. FLUSHING AND CLEANING:

A. General:

- 1) Flush, hydro-blast, or blow out all piping systems and Equipment to remove all dirt, scale, chips, and other foreign material.
- 2) Furnish and install all necessary equipment and materials required for flushing and cleaning including pumps, temporary blank-off plates, steam sources and supply lines, special fittings, temporary piping systems, gaskets, supports, anchors, and bracing required for the flushing and cleaning operations.
- 3) Provide temporary water supplies for filling and flushing and provide temporary drain lines and hoses for disposal of water without flooding.
- 4) Furnish labor and materials to dismantle Equipment and open handholes and manholes as required to inspect and clean piping and Equipment.
- 5) Furnish labor, materials, portable pumps, and equipment to clean out and inspect existing sumps and tanks.
- 6) Remove orifice plates and flow element from pipelines before cleaning and flushing and reinstall after cleaning and flushing.
- 7) Remove control valve internals before cleaning and flushing and reinstall after cleaning and flushing.

- 8) Remove, clean and replace pump suction strainers as necessary during cleaning and flushing operations.
 - 9) Protect all equipment during cleaning and flushing.
 - 10) Protect instruments and appurtenances during cleaning and flushing.
 - 11) Remove all temporary piping, supports, anchors, bracing, fittings, and blank-off plates after flushing.
 - 12) Reassemble all Equipment ready for operation. Furnish and install new gaskets as required to reassemble Equipment.
- B. Heat Recovery Steam Generator (HRSG) cleaning:
- 1) Perform a hot alkaline detergent degreasing and cleaning of the HRSG in accordance with OEM recommended cleaning procedures. Alternative cleaning measures may be proposed by Contractor for Owner consideration, acceptance of which is in Owner's sole discretion.
 - 2) Cleaning shall be performed by a firm specializing in such services.
 - 3) Provide all required chemicals and equipment including heat source necessary to heat cleaning solution to proper temperature. Provide all piping, hoses, and drain lines required to deliver water and chemicals to the unit for cleaning. Dispose of waste offsite after cleaning is completed.
 - 4) Install orifice plates in HRSG downcomers to obtain 0.5 – 1.0 ft/sec flow rate during alkaline degrease cleaning.
 - 5) After boilout, open the unit, wash down, and inspect. Replace gaskets, gauge glasses, and other parts damaged by boilout with new parts and material.
- C. Condensate System:
- 1) Thoroughly clean the condensate system from the ACC Drain Pots to the Heat Recovery Steam Generator (HRSG) preheater inlet.
 - 2) Hydro-blast clean the condensate suction and discharge piping from the air cooled condenser drain pots to the HRSG preheater inlet connection as follows:
 - 3) Install blanking plates on the following:
 - a. Condensate Receiver Tank outlet connections.
 - b. ACC Drain Pots outlet connections
 - c. Suction and discharge of the condensate pumps.
 - d. Suction and discharge of the ACC Drain Pot Pumps.

- e. Inlet and outlet of the Inter/After condenser and gland steam condenser.
- 4) Clean the main condensate header by hydro-blasting as specified.
- 5) Hydro-blast from the tank discharge connection to the condensate pump suction strainer.
- 6) Hydro-blast from the condensate pump suction expansion joint inlet (do not hydro-blast the expansion joint) to the suction strainer.
- 7) Hydro-blast from the condensate pump discharge cleaning connection to the pump discharge connection.
- 8) Hydro-blast from the condensate pump discharge to the HRSG preheater inlet connection.
- 9) When hydro-blasting is completed remove blanking plates from Inter/After condenser and gland steam condenser and flush the main header from the condensate pump discharge cleaning connection to the HRSG preheater inlet connection with condensate. Then flush each branch line in the condensate system with condensate. Flush until system is clean as determined by Owner.

D. Feedwater System:

- 1) Thoroughly clean the boiler feed pump suction and discharge piping from the LP drum to the HP economizer inlet.
- 2) Hydro-blast clean the suction and discharge piping as follows:
 - a. Install blanking plates on the inlet and outlet of the boiler feed pumps.
 - b. Hydro-blast clean the boiler feed pump suction line from the HRSG LP drum to the pump suction connection.
 - c. Hydro-blast clean the boiler feed pump HP discharge line from the boiler feed pump HP discharge to the HRSG HP economizer inlet.
 - d. Hydro-blast clean the boiler feed pump IP discharge line from the boiler feed pump IP discharge to the HRSG IP economizer inlet.
 - e. Hydro-blast clean the boiler feed pump recirculation line from the boiler feed pump HP discharge to the HRSG LP drum inlet.
 - f. Hydro-blast clean the feedwater line from the IP economizer outlet to the fuel gas heater inlet and from the fuel gas heater inlet to the condensate header. Add blanking plates on the fuel gas heater connections during hydro-blasting operations.
 - g. When hydro-blasting is complete flush each branch line in the

feedwater system with condensate from the boiler feed discharge cleaning connection throughout the system. Flush until system is clean as determined by Owner.

E. Steam Systems:

- 1) Thoroughly clean the following steam system main lines by hydro-blasting:
 - a. Main high pressure steam lines from the main steam turbine stop valves to the HRSGs superheater outlet.
 - b. Main high pressure steam bypasses to cold reheat line.
 - c. Main high pressure steam reverse flow discharge valve to condenser (if applicable).
 - d. Hot reheat steam lines from the hot reheat stop valve to the HRSG reheater outlet.
 - e. Hot reheat steam line bypasses to the condenser.
 - f. Cold reheat steam lines from the steam turbine cold reheat check valve to the HRSG reheater inlet.
 - g. Low pressure steam lines from the LP inlet butterfly isolation valves at steam turbine or the HRSG LP superheater outlet.
 - h. Low pressure steam line bypasses to condenser.
 - i. Power augmentation steam lines from the HP steam line to the Combustion Turbine (GTG) power augmentation steam inlet.
 - j. All common steam lines as listed above.
- 2) Install blanking plates where required.
- 3) Perform steam blow cleaning as specified below.

F. Hydro-blasting requirements:

- 1) Hydro-blasting equipment minimum requirements shall be as follows:
 - a. Shall be high pressure water nozzle cleaning designed to be self propeller and revolve.
 - b. Cleaning nozzle shall be supplied with a minimum pressure of 13,000 psig and a minimum flow of 50 gpm.
 - c. Nozzle rotation speed and feed rate shall be as required to blast clean 100 percent of the interior pipe surface.
 - d. Nozzle withdraw rate shall not exceed 3 feet per minute and be as required to flush clean pipe.
 - e. Feed and withdraw shall provide two pass cleaning/flushing.
- 2) Remove items from Equipment and pipelines that might be damaged

during hydro-blasting, including, but not limited to, flow elements, control valves, instruments, etc.

- 3) Do not hydro-blast expansion joints.
- 4) Blast in segments as required to achieve complete cleaning.
- 5) Hydro-blast in a manner that allows water to wash debris to be flushed from system high points in the system to low points.
- 6) Direct hydro-blast discharge to plant floor drains. Install temporary pumps in the oil/water separator and discharge cleaning/flush water to plant collection sump and evaporation pond. Contractor shall confirm that waste water is suitable for discharge to the evaporation pond.

G. Water Flush Other Liquid Systems:

- 1) Flush all other systems until clean as determined by Owner.
- 2) Remove items from, blank off or bypass Equipment and pipeline items that might be damaged during flushing, including, but not limited to, flow elements, control valves, instruments, etc
- 3) Discharge flush water to plant collection sump and evaporation pond. Contractor shall confirm that waste water is suitable for discharge to the evaporation pond.
- 4) Permanent plant pumps may be used for flushing. Turn all system pumps on when flushing.
- 5) Flush the main headers and each branch line.
- 6) Flush the raw water system from the well pumps to the raw water storage tank.
 - a. Flush from each well.
 - b. Flush to include underground piping, above ground piping and branch lines.
 - c. Install temporary drainage pipe from tank inlet to equipment drains.
- 7) Flush the potable water system from the raw water supply to the potable water skid inlet and throughout the potable water system as it applies to the system extension.
 - a. Flush from the water treatment plant.
 - b. Flush to include underground piping, above ground piping and branch lines.
 - c. Install temporary drainage pipe from the potable water skid inlet to equipment drains.

- d. Flush from the potable system to each eye wash and shower and each fixture.
- 8) Flush the service water system as it applies to the system extension.
- a. From the raw water tank to the service water pumps.
 - b. From the service water pumps to the RO/Demineralizer system, blowdown tanks and miscellaneous drains tank.
 - c. From the service water pumps to hose bibs.
 - d. All other branch lines.
- 9) Flush the demineralized water system as it applies to the system extension.
- a. Flush through all demineralized water system piping and evaporative cooler make-up system.
 - b. Install blanking plates on all equipment connections. Disconnect piping at equipment and direct flush water to equipment drains.
 - c. All other branch lines.
- 10) Flush the condensate makeup water system.
- a. From demineralized water tank to condensate receiver tank and condensate system.
 - b. All other branch lines.
- 11) Flush the closed cooling water system.
- a. From the closed cooling water pump to each heat exchanger and the return line back to the pump.
 - b. Install a temporary bypass around the closed cooling water heat exchanger.
 - c. Install temporary bypasses around each heat exchanger.
 - d. All other branch lines.
- 12) Chemical feed, ammonia and sample lines. (These lines may be air blown at Contractor option.)
- a. Flush with temporary pumps.
 - b. Disconnect piping at process connections and flush water to equipment drains.
- 13) Boiler blowdown and steam turbine drains.
- a. Flush to respective blowdown and miscellaneous drains sumps.
- 14) General drains.
- a. Flush with general drains pumps.
 - b. Flush to the collection sump.

- 15) Combustion Turbine drains.
 - a. Flush with temporary pumps to the wash water sumps.
 - b. Install temporary pumps in the wash water and discharge cleaning/flush water to plant evaporative pond in a manner which does not cause erosion. Contractor shall confirm that waste water is suitable for discharge to the evaporation pond.
- 16) Open up Equipment and clean and flush.
- 17) Provide all temporary pump, pipe, and Equipment as required

H. Air blow the following systems:

- (1) Contractor shall provide source of compressed air for air blowing purposes.
- (2) Blow piping at a minimum velocity of 200 fps until air is free of grit and foreign material as determined by Owner.
- (3) Air blow the following systems:
 - a. Instrument air.
 - b. Compressed gas carbon dioxide.
 - c. Compressed gas hydrogen.
 - d. Compressed gas nitrogen.
 - e. Compressed generator gas.
 - f. Combustion turbine bleed heat lines.
 - g. All 2 inch and small Combustion Turbine Generator system lines.
 - h. All lube oil lines.

I. Equipment:

- 1) Open all Equipment installed by this Contract including, but not limited to, the following for inspection, swab, blow out, flush, and clean.
 - a. Air Cooled Condenser and condensate receiver tank.
 - b. Blowdown and miscellaneous drains tanks.
 - c. Closed cooling water expansion tank.
 - d. Wastewater tanks.
 - e. Compressed air receivers.
 - f. Ammonia Storage Tank.
 - g. Raw Water Storage Tank.
 - h. Oil/water separator.
- 2) Thoroughly inspect, clean, and flush any other Equipment affected by the flushing operations.
- 3) Furnish and install new manhole gaskets as required.

- 4) Contractor shall submit manufacturers recommended cleaning procedures for the Air Cooled Condenser System for Owner review and approval.

J. Lubricating and Hydraulic Oil Systems:

- 1) Thoroughly clean and flush steam turbine and boiler feed pump lubricating and hydraulic oil systems until clean and in accordance with manufacturer recommendations and instructions.
- 2) Provide a separate flushing pump for the steam turbine lube oil flush.
- 3) Heat oil, circulate oil, vibrate lines, clean strainers, and replace filters in accordance with Equipment manufacturer's instructions. Contractor shall furnish all flushing oils. Flushing oils shall meet the requirements the equipment manufacturers.
- 4) Contractor shall be responsible for all costs and equipment associated with flushing oil testing required to confirm if the oil system flushing operations has satisfied the manufacturer's requirements and recommendations.
- 5) Drain systems, dispose flushing oil off site, wipe out reservoirs, and clean as required.
- 6) After flushing dispose flushing oil offsite. Fill lubricating systems with oil and lubricate Equipment.

K. Initial Turbine Operation:

- 1) After turbine stretch-out or when directed by Owner, dump the Condensate Receiver Tank to waste for proper disposal off-site by Contractor.
- 2) Clean and flush condensate receiver tank and LP drum.
- 3) Furnish and install new manhole gaskets as required.
- 4) Repack valves, retighten flanges, tighten valve bonnets, and make repairs and adjustments for all piping systems, equipment, and appurtenances installed under this Contract.at least once during initial operation.

2. WATER LINE STERILIZATION:

A. General:

- 1) Sterilize entire potable water system installed under this Contract. Sterilize the system from the potable water treatment system connection throughout all potable water pipe lines up to and including fixtures.
- 2) Provide all required materials including the following:
 - a. High test hypochlorite (HTH) with 65% available chlorine.
 - b. Sterilized pipe, valves, fittings, and accessories.

B. Sterilization:

- 1) Perform sterilization as follows:
 - a. Flush lines with clean water.
 - b. Make slurry of HTH in separate container.
 - c. Simultaneously add slurry and water to obtain a uniform concentration of 40 ppm of available chlorine throughout the system.
 - d. Maintain system full for 6 hours during which time all valves and faucets shall be operated several times.
 - e. Drain and flush system with potable water until residual chlorine content is not greater than 0.2 ppm.
 - f. Allow system to stand full for 24 hours.
 - g. Draw sample under direction of Owner and designated officials.
 - h. Test sample in approved laboratory for bacterial count, and as directed by health authorities.
- 2) After sterilization make connections to system with sterilized fittings only.

3. STEAM LINE BLOWDOWN:

A. General:

- 1) Clean each Heat Recovery Steam Generator (HRSG) and steam lines with steam with low pressure, high velocity continuous blows to completely clean the lines to the satisfaction of Owner.
 - a. Provisions shall be made to thermally shock the steam lines without affecting the steam drums.
 - b. Blowdown steam lines in accordance with a schedule approved by Owner. Owner will notify the proper authorities of the time and duration of the blows.

- c. Contractor shall design the temporary steam blow system and shall furnish and install all temporary piping, silencers test targets (coupons), valves, thermocouples, pressure gauges, anchors, and supports required for blowing steam lines as indicated on the drawings and as required.
- d. Discharge of steam blows shall not enter the condensate system.
- B. Furnish all labor and attendance, and pay all expense for overtime work required to blow steam lines and install or remove temporary pipe, valves, and related items between blowing sequences. Blow steam lines around the clock including weekends and holidays if so directed by Owner. Contractor shall be responsible for obtaining permitting for such work, as required.
- C. Steam line blowdown shall be performed by a firm specializing in such services.
- D. System Design:
 - 1) The temporary pipe and silencer shall be sized to provide a cleaning mass ratio of 1.5 through the steam system. The cleaning mass ratio is defined as:

$$\text{C.R.} = \frac{M_B^2 V_B}{M_D^2 V_D}$$

where M_B is the main steam flow during steam blow, V_B is the steam specific volume measured at the superheater outlet, M_D is the design operating main steam flow, and V_D is the design operating specific volume.

- 2) Steam line conditions for determining the cleaning mass ratio shall be provided by Contractor for Owner review.
- 3) Contractor shall submit calculations verifying the cleaning mass ratio at the superheater outlet and at the highest velocity on the main steam line, attemperation water flow rates required, and condensate makeup water flow rates required.
- 4) System shall be designed to inject water in the temporary vent piping and the vent silencer to reduce the steam velocity and temperature. Contractor to provide temporary piping from the construction water system to the injection points. All valves, piping and fittings shall be

furnished by the Contractor.

- 5) Additional attemperation water will be supplied through temporary feedwater attemperation lines installed by this Contract to shock the steam lines through steam attemperation. Contractor shall provide any temporary piping hose fittings, or equipment required to supply attemperation water to the steam line connections required for thermal shocking.
- 6) Steam blow test coupons shall be installed in the temporary piping upstream of final quenching water. Test coupon shall be designed for quick and easy removal and inspection and insertion into the temporary piping.
- 7) Steam line blowdown test coupon acceptance criteria shall be as follows:
 - a. No raised impacts shall be visible.
 - b. No greater than three visible impacts for two consecutive steam line blowdown cycles.
 - c. In accordance with steam turbine manufacturer's requirements.
- 8) All temporary piping hanger to supports shall be designed in compliance with SECTION 5 of this Specification.
- 9) Test coupons shall be made available to Owner 30 days prior to conducting the steam line blowdown.
- 10) A temporary silencer shall be utilized and shall be designed for a maximum steam velocity of 50 ft/min. Silencer shall be capable of limiting the steam discharge sound pressure level to 85 dBA at 100 feet from the silencer. Silencer location shall be such that the silencer exhaust plume will not impact existing structures or electrical lines. Silencer location shall be located a significant distance from the steam turbine building (minimum of 75 feet) and shall be subject to the approval of Owner.
- 11) Contractor shall supply mobile demineralizer as required to provide demineralized water for steam blows. Contractor shall supply temporary hose from the mobile demineralizer to the demineralized water storage tank and/or condensate receiver tank.
- 12) Demineralized water quality shall be as follows:
 - a. Conductivity, micromhos/cm at 25°C, < 0.15
 - b. Sodium, mg/l as Na < 0.003

- c. Silica, mg/l as SiO₂ < 0.010
- d. Chloride, mg/l as Cl < 0.003
- e. Sulfate, mg/l as SO₄ < 0.003
- f. Total Organic Carbon, mg/l as C < 0.100

- 13) Existing site construction water source is well water. Raw water quality shall be as indicated in Appendix I.
- 14) Wastewater from the Contractors temporary mobile demineralizer shall be disposed of off site by the Contractor.
- 15) Use test coupons installed in the exhaust lines to indicate when lines are clean. Test coupons shall be 1 inch wide and extend the full diameter of the line being blown. Test coupons shall be made from AISI 1030 brass keystone and shall be ground and polished so that the root mean square surface irregularities does not exceed 16 micro-inches. Lines will be considered clean when test coupons are acceptable to Owner.

- E. Owner will operate combustion turbine and heat recovery steam generator to generate steam at Contractor specified conditions for steam blows.
- F. After Owner acceptance of test coupons, remove all temporary piping, supports, and associated material. Reassemble valves under Owner supervision. The Owner will inspect the existing main steam/hot reheat/cold reheat tie-ins for cleanliness prior to making the final fit-up.
- G. At no time is it acceptable for Contractor to make any temporary weld to any critical piping system or associated equipment for support or any other reason, without approval from Owner.

4. STEAM BLOWING SEQUENCE:

A. General:

Portions of the cold reheat and the low pressure steam line may not be included in the steam blow (at the turbine connections). For sections of piping, which will not be in steam blow, piping shall be received from fabricator clean, shop blasted, and sealed. Contractor shall assume all responsibility in assuring piping is protected against any contamination. Immediately before installation, and upon completion of steam blows, Contractor shall provide means for Owner to perform visual inspection of the piping. Final piping welds shall not be

performed until Owner has signed off on all piping inspections.

Furnish and install temporary steam blow piping, blow valves and silencers.

Install stop valve blow kits.

B. First Blow

- 1) Steam blowdown will begin after all temporary piping, silencers and demineralized water makeup systems are installed.
- 2) Owner will operate the combustion turbine to provide a heat source to generate steam from the HRSG. Steam drum pressure will be held constant during the steam line blowdown.
- 3) Install blow kits in the main steam stop valves.
- 4) Furnish and install temporary blow piping from the stop valve to a safe discharge point outdoors. Piping shall include blow valve and silencer.
- 5) Blow from the HP drum through the HP steam piping and the steam turbine HP stop valves, through temporary piping and blowdown valve to exhaust silencer.
- 6) After a period of blowdown, the attemperation water flow shall be increased to shock the main steam line. Steam line shock will be repeated as directed by Owner to enhance cleaning.
- 7) Install test coupons after a period of steam line blowdown.
- 8) The initial blow shall clean from the HRSG through main steam piping and out temporary piping to a silencer. The first stage blow shall be completed only after Owner acceptance of test coupon insertion test result.
- 9) Blow through HRSG, main steam piping, stop valve, temporary piping, and blowdown valve to atmosphere until clean.

C. Second Blow:

- 1) Furnish and install bypass piping and temporary blowdown valve from main steam outlet to cold reheat connection at the steam turbine.
- 2) A temporary connection shall be made to the cold reheat piping at the steam turbine and shall be performed by this Contract.
- 3) Contractor shall provide temporary attemperation line in the temporary piping between the main steam and cold reheat line to limit the temperature of the steam entering the cold reheat line to the cold reheat design temperature limit.
- 4) Install blow kits in the hot reheat steam stop valves.

- 5) Furnish and install temporary blow piping from the stop valve to a safe discharge point outdoors. Piping shall include blow valve and silencer.
- 6) Contractor shall provide temporary attemperation line in the temporary piping between the main steam and cold reheat line to limit the temperature of the steam entering the cold reheat line to the cold reheat design temperature limit.
- 7) Blow from the main steam piping, through the main steam bypass to hot reheat piping, hot reheat stop valves and temporary piping to atmosphere until clean.
- 8) Blow from the IP drum to the cold reheat inlet connection and then blow through the reheater, hot reheat piping, hot reheat stop valves and temporary piping to atmosphere until clean.
- 9) Blow through main steam piping, through main steam to cold reheat bypass piping, cold reheat piping, to the reheater, hot reheat piping, hot reheat stop valves and temporary piping to atmosphere until clean
- 10) Blow through main steam piping, stop valve, bypass piping, cold reheat piping, to the reheater, hot reheat piping, hot reheat stop valves and temporary piping to atmosphere until clean.
- 11) After a period of blowdown, the attemperation water flow shall be increased to shock the reheat steam line. Steam line shock will be repeated as directed by Owner to enhance cleaning
- 12) Third stage blow shall be completed only after Owner acceptance of test coupon

D. Third Blow (may occur concurrently with other blows):

- 1) LP steam blowdown will begin after all temporary piping, silencers and condensate makeup systems are installed.
- 2) Furnish and install temporary blow piping from the strainer upstream of the turbine to a safe discharge point outdoors. Piping shall include blow valve and silencer.
- 3) Install test coupons after a period of steam line blowdown.
- 4) The LP steam blow shall clean from the HRSG LP drum through low pressure steam piping and out temporary piping to a silencer. The fourth stage blow shall be completed only after Owner's acceptance of test coupon insertion test result.
- 5) Blow through LP steam piping, stop valve, temporary piping, and blowdown valve to atmosphere until clean.

E. Additional Steam Blows:

- 1) Contractor shall blow remaining lines as required for service blows, which shall include at least:
 - a. Main Steam to Combustion Turbine (Power Augmentation Steam Line, if applicable)
 - b. Hot Reheat Bypass to Condenser
 - c. LP Steam Bypass to the Condenser
 - d. Steam cold reheat lines through the Turbine Gland Steam System
 - e. Auxiliary Boiler steam lines through the Turbine Gland Steam System, steam jet air ejectors, condenser sparger, HRSG spargers.
 - f. Other steam system lines as designated by the Owner.
 - g. No steam blow discharge shall pass into the condenser and/or condensate system.

5. FUEL GAS LINE BLOWDOWN AND CLEANING:

A. General:

- 1) Fuel gas line shall be cleaned in accordance with gas turbine manufacturer's gas cleaning procedure or as defined herein, whichever is more stringent.
- 2) Clean the fuel gas system by blowing down the main line from the gas metering station to each combustion turbine main inlet with enough blows to completely clean the lines of all foreign matter and to the satisfaction of the Owner and Engineer.
- 3) Blowdown fuel gas lines in accordance with a schedule approved by Owner. Owner will notify the proper authorities of the time and duration of the blows.
- 4) No welding, grinding or other activities that could generate a spark shall be conducted during the blowing operation.
- 5) Perform blowing and line cleaning operations in accordance with Equipment manufacturer's cleaning procedures and as specified herein.
- 6) Blowing procedure shall be developed by Contractor and submitted to Owner for review and approval. Procedure shall blow clean all fuel gas piping from the fuel gas yard to inlet of the filter separators. After

this segment is clean, blow from the filter/separators to the combustion turbine accessory modules.

- 7) Blow down piping with at least 4 short duration blows (approx. 15 seconds), then blow with at least 4 medium duration blows (approx. 60 seconds), then blow with long duration blows (approx. 2 minutes) until clean
- 8) Furnish and install all temporary piping, blanking flanges and plates, valves, thermocouples, pressure gauges, anchors, and supports required for blowing fuel gas lines as indicated on the drawings and as required. Remove valve internals and inline flow elements during blowing.
- 9) Install temporary piping to bypass the heat exchangers, knock out tank and filter separator during the initial blows. Remove temporary piping during the final blows and blow through the heat exchangers, knock out tank and filter separator.
- 10) Remove filter separator internals during blowing operations. Inspect and remove all foreign matter from filter separator after blowing operations. Reinstall internals when blowing is completed.
- 11) Furnish and install all required temporary blowdown piping and valves as required to discharge blow gas in a safe location. The temporary blowdown valves shall be equipped with a pneumatic operator with an opening and closing time under pressure not exceeding 10 seconds.
- 12) Gas line blowdown test target acceptance criteria shall be as follows: No visible impacts, pits, dings or holes shall be visible.
- 13) Use test targets installed at the exhaust lines to indicate when lines are clean. Test targets shall be made from 2 foot by 2 foot plywood painted white. Position test target at a 30 or 45 degree angle to the exhaust pipe and position the centerline of the target 2 foot from the exhaust pipe exit.
- 14) Lines will be considered clean when test targets are acceptable to Owner.
- 15) Furnish all labor and attendance, and pay all expense for overtime work required to blow fuel gas lines. Blow fuel gas around the clock and on weekends and holidays if so directed by Owner.
- 16) Fuel gas blowdown shall be performed by a firm specializing in such services.

- 17) The temporary pipe and silencer shall be sized to provide a cleaning mass ratio of 2.0 through the fuel gas system. The cleaning mass ratio is defined as:

$$\text{C.R.} = \frac{M_B^2 V_B}{M_D^2 V_D}$$

where M_B is the fuel gas flow during gas blow, V_B is the fuel gas specific volume measured at the fuel gas meter yard, M_D is the design operating fuel gas flow upstream of the combustion, and V_D is the design operating main fuel gas specific volume.

- 18) Fuel gas blow test targets shall be installed at the temporary piping exhaust at a safe location as approved by Owner. Test target shall be designed for quick and easy removal and inspection and reinstallation at the exhaust of the temporary piping.
- 19) All temporary piping hanger to supports shall be designed in compliance with this Specification.
- 20) Test targets shall be made available to Owner 15 days prior to conducting the gas line blowdown.
- 21) Owner will furnish the fuel gas for the gas blows.
- 22) After Owner acceptance of test targets, remove all temporary piping, supports, and associated material. Reinstall the filter/separator internals. Reconnection Combustion Turbine Accessory Module. Owner will inspect the tie-ins for cleanliness prior to making the final fit-up.
- 23) After completing blow procedure clean gas piping in accessory module and downstream to combustion turbine injection nozzles. After cleanliness verification by Owner, restore the system when complete.

B. Gas Blowing Sequence:

- 1) First Blow:
- a. Bypass the gas fired heat exchangers and hot water heated fuel gas heaters.
 - b. Furnish and install temporary blow piping including blow valve and silencer and which discharges to a safe point.
 - c. Blow from the gas yard to the filter/separator inlets until clean.
 - d. The first stage blow shall be completed only after Owner

acceptance of test coupon insertion test result.

2) Second Blow:

- a. Close Bypass and open flow through the gas fired heat exchangers and hot water heated fuel gas heaters.
- b. Blow from the gas yard to the filter/separators inlet until clean.
- c. The first stage blow shall be completed only after Owner acceptance of test coupon insertion test result.

3) Third Blow:

- a. Install blanking plate at accessory modules.
- b. Furnish and install temporary blow piping including blow valve and silencer and which discharges to a safe point.
- c. Blow from the gas yard to the accessory module inlets until clean.
- d. The third stage blow shall be completed only after Owner's acceptance of test coupon insertion test result

6. INITIAL OPERATION:

A. General:

- 1) As soon as Contractor's equipment, system or a portion of a system is completed in accordance with Owners defined turnover packages (to be provided after Contract award) and ready for turnover, Owner will perform a walk down of the equipment, system or a portion of a system as follows:
 - a. Contractor shall notify Owner as soon as a system is ready for initial operation.
 - b. Owner will inspect the system to ensure that all work required preparing it for initial operation has been completed.
 - c. As soon as Owner is satisfied that a system has been properly prepared for initial operation, Owner will give Contractor written notice that it is accepted for initial operation. Owner will furnish Contractor an exceptions list for system completion and correcting.
 - d. After acceptance for initial operation, Owner will assume all operational and maintenance duties as defined. All other Contractor's personnel are specifically prohibited from starting or stopping any equipment in the system, opening or closing any valve in the system, operating any switches, breakers or controls

in the system, or performing any other operational and maintenance duties whatsoever.

- 2) When the Owner accepts a system or a portion of a system for operation it will be so marked in accordance with the Project standard marking system (to be provided after Contract Award).
 - 3) After acceptance for operation, Contractor shall continue to provide all specialized personnel and attendance required to correct defective material and workmanship and to perform the Work specified within.
 - 4) Acceptance by Owner of a system or a portion of a system for initial operation does not constitute final acceptance for making final payment nor does it constitute that the system is properly constructed and/or adjusted for proper operation.
 - 5) Contractor shall follow instructions given in manuals supplied by the manufacturer of equipment and materials for erection, installation, cleaning, testing, checkout and start-up.
 - 6) Contractor shall follow instructions of service representative of equipment and materials.
 - 7) Contractor shall cooperate with Owner and manufacturer's service personnel during the start-up period.
 - 8) Contractor shall strictly enforce his own and Owner's safety measures for the protection of equipment and personnel. Owner's tagging procedure shall be strictly complied with.
- B. Equipment and System Turnover Packages:
- 1) The Acceptance for Initial Operation Turnover Package shall contain the following items, and shall be documented in the manner indicated:
 - a. Agreement for Acceptance for Initial Operation form signed by the responsible personnel.
 - b. Table of Contents sheet listing the documents contained in the Turnover Package.
 - c. A copy of the Construction Exceptions List and the Deficiency List with a status of items noted.
 - d. Performance Test data sheets signed and dated by designated personnel.
 - e. Lubrication and alignment data sheets signed and dated by designated personnel.
 - f. Marked-up P&ID drawings, electrical schematics and any other

drawings necessary to define the system boundaries. All drawings shall be current with all known corrections made prior to Acceptance for Initial Operation.

- g. List of instruments by instrument number that are within the scope of the system boundaries.
 - h. A list of equipment that is within the scope of the system boundaries.
- 2) System Turnover boundaries shall be established by Owner to reflect functional systems. Each system shall be assigned a system designator by Owner, and Owner will prepare a system turnover schedule. Every reasonable effort shall be made on the part of all responsible parties to turnover systems within the boundaries described on the scheduled date.
 - 3) Approximately six (6) to eight (8) weeks prior to the scheduled turnover date, Contractor shall conduct an informal walkdown of the system with his subcontractors and Owner. This early informal walkdown will define the system boundaries. The informal walkdown shall mark the beginning of the Construction Exception and Start-up Deficiency listing process. One (1) to two (2) weeks prior to the scheduled turnover date, Contractor shall perform a final pre-turnover walkdown. An official Exception List and a Deficiency List shall be prepared at this time. These Lists are to be agreed upon by all parties as exceptions to the system turnover. Those items that Owner indicates must be completed prior to turnover shall be so noted on the Construction Exception List.
 - 4) Once the proper signatures have been affixed, the package will be transmitted to Owner for review and acceptance. Owner will also review the turnover package. If accepted by Owner, Contractor shall release all Construction safety tagging within the boundaries of the turnover and Owner shall affix tags/labels where necessary to signify jurisdictional transfer to Owner. If necessary, the Turnover Package shall be returned for completion to Contractor with a written description of outstanding items.
 - 5) When performing the final walkdown between Owner and Contractor, all known exceptions shall be clearly identified and documented. All exceptions shall be noted on the up Deficiency List or on the Construction Exception List. Control of the Exception List shall be as follows:

- a. Exception List shall be numbered in accordance with the turnover schedule.
 - b. Owner shall maintain control of the both Exception and Deficiency Lists until completed.
 - c. The Construction Exception List and the Deficiency List with estimated completion dates for open exceptions shall be transmitted to Owner with the Turnover Package.
 - d. Contractor shall meet scheduled completion dates for turnover exceptions and notify Owner of each item completed.
 - e. Contractor shall contact Owner to obtain safety tag clearance as required for completion of turnover exception items.
 - f. Contractor shall document the completion of each exception on the list.
 - g. Contractor shall, as required, transmit copies of updated Exception Lists to Owner.
- 6) Once Owner accepts the Turnover Package, Owner will place Owner tags or labels on all major valves, boundary valves, breaker panels and breaker panel control switches, various control switches, instrument and instrument panels and other components as necessary to identify boundaries and equipment within boundaries. Once tags are hung, no Contractor personnel shall be permitted to operate or otherwise work on the equipment under tags unless clearance is obtained from Owner. All boundary valves or breakers shall be safety tagged to prevent Owner from interfering with construction activities. Turnover from Contractor is not complete until tagging is complete. Tags or labels indicate jurisdictional transfer only. These are not to indicate safety protection for personnel or protect equipment from accidental damage. If protection for personnel or against equipment damage is deemed necessary by Contractor or Owner, the appropriate safety tags will be hung in accordance with a Safety Tagging Procedure.

7. PERFORMANCE AND ACCEPTANCE TESTS:

- A. Summary
 1. All Performance and Acceptance Tests shall be witnessed by the Owner. Contractor will provide reasonable notice to Buy of any the above tests.

2. Contractor, or its Subcontractors, shall conduct the Performance Tests associated with both Substantial Completion and Final Completion of the Facility.
3. This Section specifies the requirements for Performance Tests of the Facility and Materials and Equipment demonstration tests. Before performing any Facility Performance Tests for capacity and heat rate, the Emissions Test and Noise Level Test shall be performed. The Emissions Test is performed to demonstrate that the Emissions meet the Emissions Guarantee and requirements of the air permit. The Noise Level Test is performed to demonstrate that either the Noise Level Guarantee is met or any failure to achieve the Noise Level Guarantee does not preclude Owner from operating the Facility. The test procedures shall include correction curves for operating conditions which vary from guarantee, including, but not limited to, ambient air temperature, ambient air pressure, ambient air humidity, fuel constituent analysis, generator power factor, steam generator blowdown rate, make-up water conditions, and fuel supply temperature and pressure.
4. Acceptance and performance tests will be conducted by Contractor as soon as possible after initial operation to meet the performance guarantees.
5. Acceptance tests shall include a load rejection test at full turbine-generator load. A full-load turbine trip shall also be demonstrated.
6. Contractor shall furnish, maintain, and remove all special test equipment and instruments required for the tests which are not part of the permanent installation.
7. Owner will furnish operating labor assistance.
8. Owner will provide fuel up to the quantities specified in the APSA. Additional fuel quantities will be provided by Owner, but subject to reimbursement by Contractor under the APSA.
9. Contractor shall provide services of sound specialist equipped with adequate sound level meters and an octave band noise analyzer to measure the performance of the silencing equipment.
10. Performance tests will be made in accordance with a test method mutually agreed upon by Owner and Contractor.

B. Testing Sequence and Schedule

1. Facility Performance Tests

- a. Prior to Substantial Completion, Contractor shall conduct a Performance Test that demonstrates at least 95% of the Net Electrical Capacity Guarantee while operating at a Net Heat Rate of not more than 105% of the Net Heat Rate Guarantee while maintaining environmental compliance with all air permit requirements. Improperly operating Materials and Equipment may be corrected by Contractor prior to Performance Tests. The sequence for testing of the Facility and Material and Equipment shall be agreed to between the Parties. Materials and Equipment demonstration testing may be conducted prior to or after Substantial Completion, but must be conducted prior to Final Completion.
- b. If Performance Tests prior to Substantial Completion do not demonstrate 100% of Net Electrical Capacity Guarantee and 100% of Net Heat Rate Guarantee, and 100% of Duct Fired Net Unit Capacity Guarantee, then prior to achieving Final Acceptance of the Facility, Contractor shall conduct a final Performance Test to determine final Net Electrical Capacity and Net Heat Rate, and 100% of Duct Fired Net Unit Capacity Guarantee.
- c. Prior to Substantial Completion, Contractor shall conduct Functional Testing of the Facility. The following tests shall have been successfully completed:
 - (1) Plant Hot Start - Contractor will complete two (2) tests that demonstrate the ability of the Plant to start-up from a hot standby condition (overnight shutdown equivalent, 8 hours or less) to base load condition (each Gas Turbine at its normal firing temperature limit without duct firing) within 105 minutes.
 - (2) Plant Full Load Capability Test - Contractor will complete one (1) test during a Plant Hot Start test in (i) above that demonstrates the ability of the Plant to reach full duct-fired Plant capability (each Gas Turbine at its normal full load firing temperature limit and the HRSG is duct firing at the maximum duct burner fuel flow for the ambient conditions of the test within 165 minutes.

- (3) Plant Partial Load Operational Test - Contractor shall demonstrate that the loading on the Plant can be successfully and smoothly transitioned from full load to the OEM's minimum load in 10% load increments. The Plant shall be operated with stable output at each load setting for a period of not less than 60 minutes at each load setting.
 - (4) Plant Shutdown Test - Contractor will complete two (2) consecutive tests that demonstrate the ability of the Plant to safely shutdown from base load condition to a hot standby condition within 45 minutes.
- d. Prior to Final Acceptance, Contractor shall conduct additional Functional and Average Equivalent Availability Testing of the Facility. The following Functional Tests shall have been successfully completed:
- (1) Plant Cold Start - one (1) test that demonstrate the ability of the Plant to start-up from a cold standby condition (shutdown for 72 hours or more) to base load condition (each Gas Turbine at its normal firing temperature limit without duct firing) within 270 minutes.
 - (2) Plant Warm Start - two (2) consecutive tests that demonstrate the ability of the Plant to start-up from a warm standby condition (weekend shutdown equivalent, or 48 hours) to base load condition (each Gas Turbine at its normal firing temperature limit without duct firing) within 150 minutes.
 - (3) Plant Hot Start - two (2) tests that demonstrate the ability of the Plant to start-up from a hot standby condition (overnight shutdown equivalent, 8 hours or less) to base load condition (each Gas Turbine at its normal firing temperature limit without duct firing) within 105 minutes. In the event the Plant demonstrated a Plant Hot Start time less than or equal to the time in the immediately preceding sentence during the Function Test pursuant to this Section, this Functional Test shall not be a condition of Final Acceptance and shall be deemed satisfied.

- (4) 1x1 Operational Test - one (1) test of each Gas Turbine that demonstrates its ability to operate in a 1x1 operating mode. The functional test shall consist of startup from a hot standby condition, operate at full load for two hours (120 minutes), and safely shutdown within a total of 350 minutes.
 - (5) Full Load Steam Bypass To Condenser - one (1) test that demonstrates the ability of the steam turbine to be tripped off line with the Plant at full load capacity so that the Gas Turbines continue to operate at full load with steam from the HRSGs bypassed to the condenser for a period of not less than four (4) hours.
 - (6) Auxiliary Boiler Capability Test (if applicable) - one (1) full load capability demonstration test of the ability of the auxiliary boiler to produce a nominal 15,000 lbs/hr of steam. The demonstration may be by the input-output method of boiler testing and utilizing only Plant instrumentation. Results shall be corrected to the boiler vendor's reference conditions and, for purposes of this demonstration, a tolerance equivalent to the test uncertainty shall be applied.
- e. A one-hundred sixty-eight (168) hours Average Equivalent Availability test will be performed as a requirement of Final Acceptance. The test period will be a rolling window interval such that for successful completion of this test, the Average Equivalent Availability during the test run of one hundred sixty eight (168) consecutive hours must not be less than ninety-five percent (95%) ("Guaranteed Average Equivalent Availability").

The term "Average Equivalent Availability" is specifically defined as follows for the purposes of the test:

$$\text{Average Equivalent Availability (\%)} = \frac{A + B + C}{D} \times 100\%$$

Where:

A = Total number of hours that the Plant is available for dispatch or operated with the breakers closed to the station bus (including time required to start up and shut down the Plant) without a load restriction on the Plant imposed by Contractor or a failure of the Plant as covered

in "C," below. Actual Plant load will be as determined by Owner.

B = The product of the number of hours that the Plant is available for dispatch or operated with the breakers closed to the station bus (including time required to start up and shut down the Plant) during which Contractor has imposed in writing a load restriction on the Plant multiplied by the percentage of load then allowed.

C = The product of the number of hours that the Plant is operated with the breakers closed to the station bus but is incapable of operating at base load or a lower dispatched load due to failure of Plant equipment in the scope of Contractor multiplied by the percentage of base load or dispatched load which is actually achievable.

D = Total number of hours of the test period.

The Average Equivalent Availability of the Plant shall be calculated at the end of the test period. If the Average Equivalent Availability of the Plant is equal to or greater than respective the Guaranteed Average Equivalent Availability, the test shall be conclusively deemed successful. If the Average Equivalent Availability of the Plant is less than ninety-five percent (95%) in the test, Contractor shall take appropriate remedial action. Following such remedial action, the test shall be reinitiated and the Average Equivalent Availability will be re-calculated on a continuing basis. Once the required value of the respective Average Equivalent Availability is achieved during the most recent testing period, the test will be deemed successfully completed.

2. Conditions Applicable to the Average Equivalent Availability Test:
 - a. Excluded are outage hours which are not under Contractor's control, including but not limited to those caused by low fuel gas supply pressure, grid frequency variations outside of the operating

manuals and instruction manuals, operator error, acts of Owner or its agents or subcontractors, and Force Majeure events.

- b. Owner shall maintain an operator log sheet, following a mutually agreeable format, indicating in detail performance parameters, cycles, and maintenance actions. Owner shall report key performance parameters on a daily basis to Contractor. Contractor may inspect the operator log sheets. Contractor, at its own expense, may provide a modem for the purpose of monitoring plant parameters during the tests. Owner will provide a phone access line for this modem.
- c. Contractor shall be entitled to have a field representative present during performance of the Average Equivalent Availability tests.

For the purposes of conducting these tests, a "Start" shall be deemed to be the period of time from the start of the gas turbine ignition sequence to valves wide open (HP and IP) for the steam turbine. All activities required for these startup and shutdown tests shall be performed through the Plant's Distributed Control System ("DCS") with the exception of any normally expected and routine action taken by an operator. The Plant's DCS shall control, or shall cause to be controlled, all Equipment necessary for the safe and reliable operation of the Plant with the exception of Equipment normally controlled manually.

8. TESTING STIPULATIONS:

- A. Contractor shall conduct Performance Tests associated with both Substantial Completion and Final Completion of the Facility to demonstrate performance as specified and as guaranteed.
- B. The Contractor will collect base-line data for the Materials and Equipment furnished under this Contract during the initial operation of the Facility.
- C. Contractor shall be required to abide by the results of the tests, or shall provide all additional Materials and Equipment and instruments, make all preparations, furnish testing personnel, and incur all expenses connected with supplementary Performance Tests. Supplementary Performance Tests shall be scheduled at the convenience of Owner. Owner will

observe such supplementary Performance Tests and shall be furnished with a complete set of test data and results. If specified conditions are not met, Contractor shall modify or replace the Materials and Equipment to obtain satisfactory performance.

- D. Contractor shall submit detailed written test procedures for all Performance Tests to the Owner and Engineer for review and approval not later than 120 Days prior to the start of the initial Performance Test.
- E. Contractor shall furnish Owner six (6) hard copies and one (1) electronic copy of all test data sheets, test calculations, and the test report for all tests required herein.
- F. Contractor shall furnish and connect all test instruments required by the ASME codes or other appropriate code or standard, if applicable, in addition to normal Facility instruments. With the exception of those connections and devices needed to demonstrate Contractor has met its Gross Auxiliary Electrical Load Guarantee and Water Consumption Guarantee, the Contractor shall ensure that all necessary connections and devices required for the Performance Tests are provided for in the design phase of the Work so that modifications to permanent equipment or systems are not required immediately prior to testing.
- G. Contractor shall make all preparations, furnish all testing personnel, and incur all non-Owner expenses connected with the tests.
- H. Should any Materials and Equipment fail to operate as required, or in case of failure to meet any Contractor guarantees, Owner shall have the right to operate the Materials and Equipment until such defects have been remedied and guarantees met. In the event that defects necessitate the replacement of the Materials and Equipment or any part thereof, Owner shall have the right to operate the Materials and Equipment until such time as new Materials and Equipment are provided to replace the defective Materials and Equipment. Removal of defective Materials and Equipment shall be scheduled at Owner's convenience and discretion, which shall not be unreasonably withheld.
- I. All costs to prepare the Facility for a Performance Test shall be to the Contractor's account.
- J. Instruments shall be calibrated by the Contractor before the tests. Calibration is defined as comparison of a test instrument's indication against a known standard. Instrument calibrations, where applicable, may

be applied to raw data to calculate test results.

- K. A deadband of 1.0% ($\pm 0.5\%$) is applicable to the guaranteed Net Electrical Capacity and Net Heat Rate. In comparison of a test result to the Net Electrical Capacity Guarantee and Net Heat Rate Guarantee, the deadband will be superimposed over the guarantee. The Contract guarantee will be deemed fulfilled if the test result falls within the dead band, or, if outside the deadband, the test result indicates better performance than the Contract guarantee. No allowances shall be made for instrument uncertainty.
- L. Contractor shall submit degradation curves and calculations for all equipment with the detailed written procedures that shall be used to correct Performance Test results to guaranteed performance conditions, as applicable.
- M. The Performance Guarantees shall apply to a Facility in a new and clean condition. However, no adjustments shall be made for operation of the unit(s) under Contractor's responsibility during the start-up and commissioning phase.
- N. If operation and performance of the Facility is unsatisfactory due to any deficiency in Contractor's Work, Contractor shall make repairs and re-perform or replace his Work to obtain satisfactory operation and performance and shall provide evidence satisfactory to Owner that his corrective work has corrected the defective work. Performance improvements arising out of a remedy shall be calculated based on the difference between a Performance Test performed immediately before and another one immediately after a remedy is implemented. Requirements for re-testing due to deficiencies shall be mutually agreed upon by the Parties.

9. EQUIPMENT DEMONSTRATION TESTING:

- A. Contractor shall perform demonstration tests of major equipment provided by Contractor or Owner. These tests shall be conducted to verify Subcontractor Materials and Equipment performance. Materials and Equipment demonstration tests are not Performance Tests, they are the tests and checkouts used during commissioning, which verify that the

components are fully operational.

- B. Owner shall receive reasonable notice and the opportunity to witness these tests.
- C. Materials and Equipment demonstration tests shall be conducted using either permanent Facility instrumentation or temporary test instrumentation that is functioning in support of the Facility Performance Test.
- D. At least six (6) months prior to testing, test protocols for Materials and Equipment demonstration tests shall be submitted by Contractor to be agreed upon by Owner and Contractor. The intent is to determine performance of individual components to serve as a baseline for trending component performance for long term Facility operation as compared to the initial performance.
- E. Materials and Equipment demonstration tests may be conducted concurrently with the Facility Performance Test for Substantial Completion.
- F. The following equipment shall be individually tested:
 - 1) Combustion Turbine Generators
 - 2) Steam Turbine Generators
 - 3) Heat Recovery Steam Generators
 - 4) Air Cooled Condenser
 - 5) Main and Auxiliary Transformers
- G. The test procedure shall include, but not be limited to, the following, as a minimum:
 - 1) Administrative procedured
 - 2) Correction curves and sample calculations, including all corrections to be applied, in both manual and electronic spreadsheet formats
 - 3) Sample test data sheets
 - 4) Marked-up P&ID's that show the location of all test instrumentation

Prior to the Performance Tests, all Plant equipment directly associated with cycle performance shall be properly adjusted, calibrated, tuned, and washed, shall be in proper and clean working condition, and shall be functioning within its normal operating range as allowed by the equipment manufacturers.

10. FACILITY NET ELECTRICAL CAPACITY AND NET HEAT RATE PERFORMANCE TESTS:

- A. General: Performance Tests shall be run with three operators and under normal operating conditions with essential equipment in automatic control (i.e., no control system jumpers, forces, alarm bypasses, temporary hookups or special equipment to allow for operation). Safety devices, protective relays, and trips mechanisms shall be checked and confirmed operational. Contractor's testing personnel, as well as representatives of any major equipment supplier whose equipment is being tested or are performing simultaneous tests, will also be present during the conduct of Performance Tests.
- B. Performance Tests should be performed at conditions as close as possible to the reference conditions.
- C. All Performance Testing shall be subject to review and potential re-testing if performance-related control system settings are materially changed after Performance Tests have been run. Performance Test protocols shall incorporate a logical sequence of testing to reduce the potential of control system setting changes being required after related Performance Tests are run (i.e. Gas Turbine emissions and control settings should be complete prior to emissions testing, which in turn should be complete prior to Performance Testing).
- D. Facility Net Electrical Capacity and Net Heat Rate Performance Tests shall be in accordance with applicable ASME PIC test codes specifically PTC-46 "Overall Plant Performance." The Net Electrical Capacity and Net Heat Rate, and BOP Gross Auxiliary Electrical Load Guarantee test procedures shall include correction curves for operating conditions which vary from the Guarantee Conditions, including, but not limited to, ambient air temperature, ambient air pressure, ambient air humidity, fuel constituent analysis, generator power factor, steam generator blowdown rate, makeup water conditions, and fuel supply temperature and pressure.
- E. Facility input/output testing shall be performed in accordance with the following:
 - 1) Performance Tests shall be performed when the Facility is operating in steady-state full load condition without HRSG blowdown.
 - 2) Power output of the gas turbine and steam turbine generators shall be

measured with Contractor-supplied permanent Facility electrical metering.

- 3) Contractor may use the plant side revenue quality meters or provide temporary revenue quality certified meters for the measurement of net plant output. If Contractor provides temporary meters, measurement shall be performed at the high side of the step up transformers for station net power and the high side of the auxiliary transformers for the calculation of auxiliary power.
- 4) Contractor may also use the plant revenue quality metering system to calculate plant net output and station auxiliary power. Meters are provided for each generator and auxiliary transformer. The net plant output is the sum of each generator less auxiliary power less step-up transformer losses. If the meters have been configured a net plant output calculation a direct reading may be made. If not, the plant output will be calculated by summing the output of each of the generators, subtracting the auxiliary power and transformer losses.
- 5) Fuel gas mass flow to the gas turbine shall be measured during the Performance Test with the Contractor-supplied orifice plate metering run (in accordance with ASME MFC-3M) installed as a permanent Facility flowmeter. Temporary test instrumentation and applicable permanent Facility instrumentation will be used to measure fuel gas temperature, pressure, and differential pressure, as applicable. A minimum of three gas fuel samples shall be taken for analysis during each one-hour test. Natural gas conforming to the OEM's requirements, shall be provided by Owner during all tests. Natural gas samples will be collected before, during, and at the end of the performance test runs. Both Contractor and Owner receive one set of fuel samples. A third set of fuel samples is set aside that can be used in the case of subsequent disputes. A mutually acceptable independent testing laboratory will be used for analysis of natural gas. Test results shall be corrected to the performance gas analysis used for the Performance Guarantees and based on the gas analyses performed on the gas samples taken during testing. The fuel heating value shall be determined by the average value of samples taken during each test run. The cost for sampling and analysis is by Contractor. If an on-line gas chromatograph is available then these

readings may be used as the basis for all evaluations if Contractor approves. The gas chromatograph unit must, in this case, be properly calibrated prior to the Performance Test, and verification thereof must be made available to Contractor. Contractor shall always reserve the right to substitute the laboratory fuel analysis once received for the final test results. All testing and analysis shall be conducted in accordance with appropriate ASME or other mutually acceptable codes.

- 6) Ambient air temperature shall be measured using laboratory calibrated RTD's or thermocouples installed upstream of the evaporative cooler in the vicinity of the gas turbine air filters. Relative humidity shall be measured at this same location. Barometric pressure shall be measured at a site location away from building structures.
 - 7) Each Performance Test shall consist of three one-hour tests performed within an eight-hour period. Data shall be recorded at intervals in accordance with the agreed upon test procedures. These individual results shall then be averaged for the one-hour period and corrected to Guarantee Conditions. The corrected results of the three one-hour tests shall then be averaged together to determine the performance levels achieved during the Performance Test.
 - 8) The Duct Fired Net Unit Capacity Test will consist of one one-hour run performed as soon as is reasonable after the Net Capacity and Net Heat Rate Test. The results of the Duct Fired Net Unit Capacity test will be corrected to the Guarantee Conditions. If there are any limitations prohibiting full duct firing at the time of the test, then the unit may be operated at part load in order to determine by test the maximum added capacity by duct firing. In this circumstance, two one hour test runs, consisting of one unfired test run and one fired test run conducted at the same load, will be required.
- F. The Performance Tests shall be conducted as described above and the measured performance shall be corrected to Guarantee Conditions. One set of correction curves will be developed per PTC 46 for the Net Electrical Capacity Guarantee, Net Heat Rate Guarantee, and BOP Gross Auxiliary Electrical Load Guarantee.
- 1) If the corrected Net Electrical Capacity is less than the Net Electrical

Capacity Guarantee or if the corrected Net Heat Rate is greater than the Net Heat Rate Guarantee, the Facility shall be considered unacceptable and Contractor shall take appropriate action as indicated elsewhere in this Contract.

- 2) At the conclusion of the Performance Test, Contractor shall perform calculations to determine performance relative to the Performance Guarantees and shall issue a report covering the entire testing program.

11. EMISSIONS MONITORING AND SAMPLING:

- A. HRSG stack Emissions will be measured using U.S. EPA methods. Emissions Guarantees are as specified in the air permit. U.S. EPA Method 25A/18 will be used for measuring VOC. U.S. EPA Conditional Test Method 27, will be used to measure ammonia slip (NH₃). U.S. EPA Method 20 for NO_x and U.S. EPA Method 10 for CO will be used to show compliance with Unit Emissions Guarantees. Method 201A and 202 will be used for measuring particulates, and Method 9 will be used for opacity.
- B. A certified CEMS is defined as a CEMS that has been installed, calibrated, tested and maintained in accordance with the requirements 40 CFR part 75 and Part 60.

12. NOISE TESTING:

- A. After the Facility is placed into successful operation and before Substantial Completion, Contractor shall perform a Noise Level Test on the Facility and Materials and Equipment to verify compliance with Section 1.
- B. Appropriate corrections, in accordance with recognized industry standards, shall be made to the operating plant sound level measurements.

13. WATER CONSUMPTION TEST:

- A. During Performance Tests, Contractor shall demonstrate, using Contractor supplied flow measuring equipment and temporary measuring equipment, that the process Water Consumption Rate does not exceed the process Water Consumption Rate Guarantee provided by the

Contractor.

Performance Test Completion Certificate

Contractor, under the Contract dated _____, 20____, between Contractor and Owner for the Facility hereby certifies that on the __ Day of _____, 20____ the Contractor has completed a Performance Test [run or rerun]. A copy of these Performance Test results is attached hereto as Attachment A. The Performance Test [run or rerun, is or is not] the final such Performance Test to demonstrate Facility performance. [Additional or No additional] Performance Testing shall be performed.

Contractor has/has not achieved the Performance Guarantees.

Contractor has/has not achieved the Minimum Performance Standards.

IN WITNESS WHEREOF, Contractor has executed and delivered this certificate through its duly authorized representative as of the _____ Day of _____, 20____

By: _____

Title: _____

Performance Test Completion Certificate

ACCEPTANCE OF PERFORMANCE TEST COMPLETION CERTIFICATE

Owner hereby accepts the foregoing certificate and confirms that acceptance of this certificate constitutes acknowledgment by the Owner of the level of performance achieved by the Facility.

Owner's Representative hereby accepts the foregoing certificate and confirms that acceptance of this certificate constitutes acknowledgment by the Owner of the level of performance achieved by the Facility.

Consultant hereby accepts the foregoing certificate and confirms that acceptance of this certificate constitutes acknowledgment by the Owner of the level of performance achieved by the Facility.

IN WITNESS WHEREOF, Owner, Owner's Representative and Consultant have caused this Acceptance of Performance Test Certificate to be executed by their duly authorized representative as of the ____ Day of _____, 20__

OWNER'S REPRESENTATIVE

OWNER

By: _____

By: _____

Title: _____

Title: _____

CONSULTANT

By: _____

Title: _____

APPENDIX A
ABBREVIATIONS

LIST OF ABBREVIATIONS

ac	alternating current
AGC	automatic generation control
ARMA	Air and Radiation Management Administration
ASCE	American Society of Civil Engineers
ASME	American Society of Mechanical Engineers
Btu	British thermal unit
°C	degree Centigrade
CEMS	continuous emissions monitoring system
CO	carbon monoxide
CO ₂	carbon dioxide
CPCN	Certificate of Public Convenience and Necessity
CRT	cathode ray tube
GT	gas turbine
GTG	gas turbine-generator
dBA	decibel
dc	direct current
DCS	distributed control system
DNR	Department of Natural Resources
EAF	equivalent availability factor
EPC	engineering/procurement/construction
EPA	Environmental Protection Agency (U.S. unless noted)
°F	degree Fahrenheit
FAA	Federal Aviation Administration
FERC	Federal Energy Regulatory Commission
gal	gallon

GNP	Gross National Product
gpd	gallons per day
gpm	gallons per minute
Hga	mercury absolute
HHV	higher heating value
HP	high pressure
hp	horsepower
hr	hour(s)
HRSG	heat recovery steam generator
HVAC	heating, ventilating and air conditioning
Hz	hertz
I&C	instrumentation and control
in	inch(es)
IP	intermediate pressure
ISO	International Standards Organization
kV	kilovolt(s)
kVA	kilovoltampere(s)
kW	kilowatt(s)
kWh	kilowatt-hour(s)
lb	pound(s)
lb/hr	pounds per hour
LHV	lower heating value
LNG	liquid natural gas
LP	low pressure
mA	milliampere(s)
MCC	motor control center
MCR	maximum continuous rating
mgd	million gallons per day
MMBtu	million British thermal units
MVA	megavoltampere
Exhibit A	

MW	megawatt(s)
MWa	megawatt(s)
MWe	megawatt(s) electrical
MWh	megawatt-hour
NO ₂	nitrogen dioxide
NEPA	National Environmental Policy Act
NFPA	National Fire Protection Association
NO _x	oxides of nitrogen
NSPS	new source performance standards
O ₂	oxygen
O&M	operation and maintenance
PCS	Parallel Condensing System
pf	power factor
PM	particulate matter
PM-10	particulate matter below 10 microns
ppm	parts per million
ppmvd	parts per million by volume, dry
PPRP	Power Plant Research Program
PSC	Public Service Commission
PSD	Prevention of Significant Deterioration
psi	pounds per square inch
psia	pounds per square inch absolute
psig	pounds per square inch gauge
PURPA	Public Utility Regulatory Policy Act
QF	qualifying facility
RH	relative humidity
rpm	revolutions per minute
scf	standard cubic feet
SCR	selective catalytic reduction
Exhibit A	

sf	square foot
SO ₂	sulfur dioxide
STG	steam turbine-generator
TSP	total suspended particulates
UL	Underwriters Laboratory
UPS	uninterruptible power supply
V	volt
VAR	volt ampere reactive
VOC	volatile organic compounds

APPENDIX B
ACCEPTABLE VENDORS LIST

APPENDIX B
APPROVED VENDORS LIST

Approved Vendors List

Equipment / Construction Package	Approved Subcontractors / Equipment Suppliers
Steam Turbine	<i>Toshiba</i> General Electric Mitsubishi Siemens Alstom
Combined Main Stop and Control Valve/Actuator*	Rexroth
Combined Reheat Valve Actuator*	Rexroth
Gland Steam Condenser	Southern Heat Exchanger ITT Industries Thermal Engineering International Krueger Engineering & Mfg. Co. General Electric Toshiba
Gland Steam Exhauster	Gardner Denver The New York Blower Co. Chicago Blower Co. or Equivalent Toshiba
Main Oil Cooler	Tranter PHE (E) Southern Heat Exchanger ITT Industries GEA Ecoflex (E) Alfa Laval
Oil Conditioner	Kaydon TORE
Oil Mist Eliminator	Burgess-Miura Co. (E) Koch-Otto York
Actuator	Limitorque - Preferred Rotork
Steam Turbine Generator	General Electric Siemens Alstom Mitsubishi <i>Toshiba</i>
Turbine Supervisory Instrumentation Unit	Bently Nevada - PacifiCorp Standard
Position Switch	Namco Controls
Position Transmitter	M-System
Flow Indicator	Yokogawa Electric Co.
Purity Analyser	Yokogawa PacifiCorp Standard
Solenoid Valve	Asco, Co.
Positioner	Fisher Co.
Instrument Valve	Swagelok, Co. - Preferred Whitey Co. – Preferred Valves
Instrument Fittings	Swagelok, Co. - Preferred Whitey Co.
Control Valve	Fisher Co. – Preferred
I/P Converter	Yokogawa
Instrument Rack/Generator	E-One – PacifiCorp Standard
Seal Oil Gauge Panel	E-One – PacifiCorp Standard
Hydrogen Gas Measuring Rack	E-One – PacifiCorp Standard
Generator Condition Monitor	E-One, GCMX – PacifiCorp Standard
H2 Gas Dryer	LectroDryer
Combustion Turbine	General Electric 7241FA Siemens SGT5000F Mitsubishi M501F/G
Generator	General Electric

Equipment / Construction Package	Approved Subcontractors / Equipment Suppliers
	Siemens Mitsubishi Toshiba
Cooling Tower	SPX (Marley) GEA Midwest Towers, Inc International Cooling Tower
HRSGs	Deltak Corporation Nooter/Ericksen Vogt Power Alstom
HRSB Duct Burners	Coen Forney John Zink
SCR and CO Systems	Peerless Mfg. Hitachi Vector Systems
SCR Catalyst	Cormetech Hitachi (aka BHK) Argillon (formerly Siemens)
CO Catalyst	BASF Catalysts EmeraChem
Auxiliary Boiler	Babcock & Wilcox Nebraska – preferred Cleaver Brooks
HRSB Bypass Stack Damper Actuator	Limitorque – Preferred Rotork
Boiler Feed Pumps and Motors	KSB, Inc. – Preferred Sulzer Pumps Weir Pumps Ltd.
Condensate Pumps and Motors	Flowserve Johnston Pump Company Weir Pump Company Sulzer Pumps Goulds Pumps KSB
Circulating Water Pumps and Motors	Flowserve Johnston Pumps Weir Pump Company Sulzer Pumps Goulds Pumps
Component Cooling Water Heat Exchanger	GEA Rainey
Condenser, Wet Surface	Alstom Graham TEI Yuba Holtec International SPX (Marley)
Condenser, Air Cooled (ACC)	SPX (Marley) GEA
Heat Exchangers, Plate & Frame	Alfa Laval - preferred APV Graham Tranter
Water Treatment Systems (Demin)	Graver Water Co. Hungerford & Terry, Inc. Siemens Water Technologies GE Water Technologies (Glegg) Water and Power Technologies now GE

Equipment / Construction Package	Approved Subcontractors / Equipment Suppliers
Oil Water Separators	Anderson Great Lakes Environmental Highland Tank PS International (E)
Air Compressors	Atlas Copco Ingersoll Rand Gardner Denver – Preferred Sullair Cooper/Joy Industries Dresser
Air Dryers	Kemp Atlas Copco – Preferred Ingersoll Rand Sullair Gardner DenverDeltech
Fuel Gas Treatment	Anderson Separator/Clark Reliance/National Filtration Burgess Manning Flowtronex Gas Packagers GTS Energy ExterranOil & Gas Systems Peerless Total Energy Resources Tran-Am System International Exterran
Fuel Gas Heaters	Fabsco Shell & Tube LLC Thermal Engineering International (Tei) (Home Office) Burgess-Manning Inc. MetalForms Inc.
Miscellaneous Horizontal Pumps	Aurora Pumps Flowserve Goulds Pumps - Preferred Peerless Sulzer Johnston KSB
Pumps, Vertical	Aurora Pumps Goulds Pumps Flowserve Johnston
Vacuum Pumps	Graham Manufacturing Gardner Denver Nash - Preferred Nitech
Sump Pumps (Submersible)	Aurora Pumps ITT Flygt Warman ITT/Goulds Flowserve Johnston Pumps
Pumps, Fire Water	Peerless ITT A-C Pump Aurora Pumps Fairbanks Morse - Preferred
Steam Conditioning Valves (attemporators)	CCI Emerson Process Management
Fire Protection System	F.E. Moran Delta Fire Protection – Salt Lake City -Preferred Simplex/Grinnell McDaniel Fire System

Equipment / Construction Package	Approved Subcontractors / Equipment Suppliers
	Shambaugh & Son S&S Sprinkler Dooley Tackaberry Securiplex
GSU Transformers and Unit Auxiliary Transformers	ABB SiemensAreva Fortune General Electric Pennsylvania Transformer Hico Pauwels
Switchgear	GE – Preferred 4160V Square D – Preferred 480V Powell (Only if part of package) EATON/Cutler-Hammer – 4160V and 480V
Motor Control Centers	Powell (Only if part of package) Allen Bradley – Preferred for 480V MCC, 4160V MCC EATON/Cutler-Hammer – Preferred for 480V MCC, 4160V MCC
Medium Voltage Motors	ABB Inc. Hyundai WEG Marathon Motors Reliance Siemens General Electric TECO-Westinghouse Hitachi
Low Voltage Induction Motors	ABB Baldor/Reliance General Electric Siemens Toshiba TECO-Westinghouse U.S. Motors
Variable Frequency Drives	Allen-Bradley Safronics Cutler-Hammer Danfoss Mitsubishi
Isolated Phase Bus Duct	ABB Calvert Delta-Unibus - Preferred GE Canada - Preferred Hitachi
Non Segregated Phase Duct	Calvert Square D Delta-Unibus - Preferred Powell - Preferred
Power Control and Instrumentation Cables	BICC Rockbestos Supernaut Draka CableteqPirelli Okonite - Preferred Furon/Dekoron Rome Southwire - Preferred Belden – Communication Cable Preferred Kerite
High and Medium Voltage Cable	Pirelli Okonite - Preferred

Equipment / Construction Package	Approved Subcontractors / Equipment Suppliers
	Rome Kerite
Distributed Control System	Emerson Ovation - PacifiCorp Standard
Continuous Emissions Monitoring System	Environmental Systems Corporation (ECS) DAHS Software; and PacifiCorp specified instruments – PacifiCorp Standard Thermo-Fisher Scientific, 42i-NO _x Thermo-Fisher Scientific, 48i-CO Servomex 1440-Oxygen
Chemical Feed Systems	Liquitech, Inc. Neptune JCI Wadsworth Pumps Flowtronex Milton Roy (not LMI) – Preferred Nalco Johnson March Systems, Inc. Sentry Equipment Pulsafeeder
Water Sample Panel	Delphi Control Systems Johnson March Systems Sentry Equipment Corp. Waters Equipment Co.
Instrumentation Analytical Measurements	
Chromatographs	ABB Daniel (Natural Gas) EG&G Emerson Process Management Rosemount
Conductivity	Yokogawa – PacifiCorp Standard
Oxygen	Orbisphere/Hach or Yokogawa – PacifiCorp Standard
Silica	Hach – PacifiCorp Standard
Sodium	Orion – PacifiCorp Standard
pH Probe	Yokogawa – PacifiCorp Standard
Vibration	Bentley Nevada – PacifiCorp Standard
Chlorinators	Advance Capital Controls Fischer & Porter Wallace & Tieman
Computers (Flow)	Daniel Omni Fisher
Controllers, Field Mounted, Pneumatic	Fisher
Flame Supervisory Systems	Fireye Forney Honeywell Allen Bradley Iris (E)
Indicators Manometers	Dwyer – preferred Meriam
Indicators Press/Receiver Gauge	Ashcroft – Preferred
PLC	Allen Bradley - PacifiCorp Standard Control Logix or SLC 5/05 (Ethernet Version)
Transmitters, Electronic	
Differential Pressure	Rosemount Model 3051 (or approved equal) - PacifiCorp Standard
Level Measurement	
Capacitance, Etc.	AMETEK Drexelbrook Fisher
Displacement	Fisher

Equipment / Construction Package	Approved Subcontractors / Equipment Suppliers
Process Radar	Rosemount Ohmart-Vega
Custody Transfer/Radar/Displacement	Enraf Saab
Radioactive	Kay-Ray Ohmart-Vega
Ultrasonic	Endress & Hauser Inc. Kistler Morse Magnetrol Millitronics - preferred Panametrics
TDR	Magnetrol Rosemount – preferred
Magnetic Flow	Rosemount – preferred
Mass Flow	ABB/Bailey Rosemount – preferred
Pressure	Foxboro Honeywell Yokogawa Rosemount Model 3051 (or approved equal) – preferred
Target Meter	Foxboro Hersey Measurement
Temperature	Foxboro Moore Industries Fisher-Rosemount – preferred Honeywell Yokogawa
Turbine	Daniel Foxboro
Transmitters, Pneumatic	
Differential Pressure	Fisher – preferred
Level Displacement	Fisher Magnetrol
Pressure	Fisher Foxboro
Target Meter	Foxboro
Temperature	Fisher-Rosemount Foxboro
UPS	Best SCI
Valves and Regulators	
Actuators, Diaphragm	Fisher – PacifiCorp Standard
Actuators, Piston	Flowserve Automax Emerson Bettis Contromatics George-Fischer Hills-MCCanna Jamesbury Flowserve Valtek Vanton Whitey XACT
Control Valves – ON/OFF or Throttling Ball	Fisher – preferred Atwood & Morrill (E) SPX Copes Vulcan Masoneilan Jamesbury TYCO (E) Valve Technologies

Equipment / Construction Package	Approved Subcontractors / Equipment Suppliers
	Watts Cameron WKM
Positioners, Electric	Limitorque, MX – Preferred Fisher-Rosemount
Butterfly/ECC Disk	AMRI Continental Flowserve Durco Fisher-Rosemount Masonellan Neles-Jamesbury Valtek
Valves, Butterfly <24-inch	Bray Valves & Controls Dezurik Flowseal Henry Pratt Co. Jamesbury Keystone Valve KSB-AMRI
Valves, Butterfly >24-inch	Atwood & Morrill Dezurik Flowseal Grinnell Corp. Henry Pratt Co. Keystone Valve Watts
Valves, Globe	Atwood & Morrill Edwards Newco Valves Pacific Valves Whitey Yarway
Valves, Cast Steel	Atwood & Morrill Crane Edwards Pacific Valves Tyco Velan Valve Co. WM Powell Co.
Control Valves, Severe Duty, (Bypass, Recirculation, Drum level control, ACC spargers)	CCI “Drag” – PacifiCorp Standard. Steam bypass valves shall be CCI Drag technology valves, not BTG.
Valves, Forged Steel	Edwards Valves, Inc. Conval, Inc. Dresser Industrial Valve Yarway Velan Valve Corp Bonney Forge
Valves, High Pressure	Atwood & Morrill Crane Edwards Pacific Valves Tyco Velan Valve Co.
Valves, Knifegate	Warman Dezurik Newcon Clarkson
Valves, Check	APCO Crane Edward Valves Pacific Valves

Equipment / Construction Package	Approved Subcontractors / Equipment Suppliers
	Stockham Valves & Fittings Yarway/Tyco
Globe / Cage (No Split Body) 300#	Collins Instrument (Plastic) Fisher - preferred Masoneilan Samson Valke Control Component, Inc. (CCI)
Miniature / Special	Collins Instrument Research Controls Whitey
Pinch, Weir, Diaphragm	ASAHI EmersonFisher-Rosemount - preferred Grinnell Red Valve RKL
Plug	Durco Tufline
Regulators	Emerson Fisher-Rosemount - preferred Emerson Process Service Cashco
Strainers, Automatic Flushing	Hayward Strainers Hellan SP Kinney Engineers
Valves, Ball	Apollo ITT Engineered Valves Mogas Neles Jamesbury NIBCO, Inc Stockham Valves & Fittings Whitey Valve Technologies
Relief or Safety Valves	Dresser Consolidated – PacifiCorp Standard for Steam Service Anderson Greenwood Crosby Ferris
Installation Hardware	
Boxes or Cabinets – Instrument and Junctions Metal	Appleton Hoffman – preferred
Boxes or Cabinets – Instrument and Junctions Fiberglass or Plastic	Hoffman – preferred Stahlin
Cable Tray and Tubing Support Tray Metal	B-Line OBO Betterman PW
Cable Tray and Tubing Support Tray Nonmetallic	Enduro Fibergrate Seagate Stahlin
Instrument Manifolds and Valving Assemblies	Anderson Greenwood Crosby PGI Rosemount - preferred
Tubing Metal	Dekoron Thermoelectric
Tubing NonMetallic	Dekoron Thermoelectric
Fittings (Compression) Metal	Gyrolok Swagelok – Preferred

Equipment / Construction Package	Approved Subcontractors / Equipment Suppliers
Fittings (Compression) Non-metallic	JACO (Kynar)
Fittings (Compression) Valves, Metal	Anderson Greenwood Crosby Hoke PGI Whitey - Preferred
Wire Signal	Alpha Belden Dekoron
Wire Thermocouple	Dekoron
Other	
Expansion Joints	Bachmann Industries Effox Pathway Wahlco Engineered Products
Fluid Couplings	Voith
Pipe, Circulating Water	Ameron La Barge Pipe McAbee Construction Northwest Pipe Company Dixie Southern – Pending Sale in Feb '08
Pipe, Fabricated LP	Bendtec International Piping Systems McAbee Construction Team Industries Scott Process
Pipe, Supports	Lisega Bergen PTP
Tanks, Field Erected	CBI Columbian Tank Matrix Pittsburgh Tank Fisher Tank HMT, Inc
Tanks, Shop Fabricated	Arrow Tanks Eaton Modern Welding Palmer Dixie Southern– Pending Sale in Feb '08 Highland Tanks
Equipment/Construction Package	Approved Subcontractors
Fittings (Compression) Metal	Gyrolok Swagelok– preferred Nonmetallic JACO (Kynar)
Fittings (Compression) Valves, Metal	Anderson Greenwood Crosby Hoke PGI Whitey – preferred
Tubing NonMetallic	Dekoron Thermoelectric
Wire Signal	Alpha Belden Dekoron
Wire Thermocouple	Dekoron
Protective Relaying Devices and Systems	Schweitzer Engineering Labs, Inc.300 G Series – PacifiCorp Standard
Lockout Relays	Electroswitch – PacifiCorp Standard

Equipment / Construction Package	Approved Subcontractors / Equipment Suppliers
Test Switches	ABB – Preferred States
Revenue Meters	Landis & Gyr 2510 (or most recent Landis & Gyr replacement, approval required before use) – PacifiCorp Standard

APPENDIX C

CONCEPTUAL SITE ARRANGEMENTS

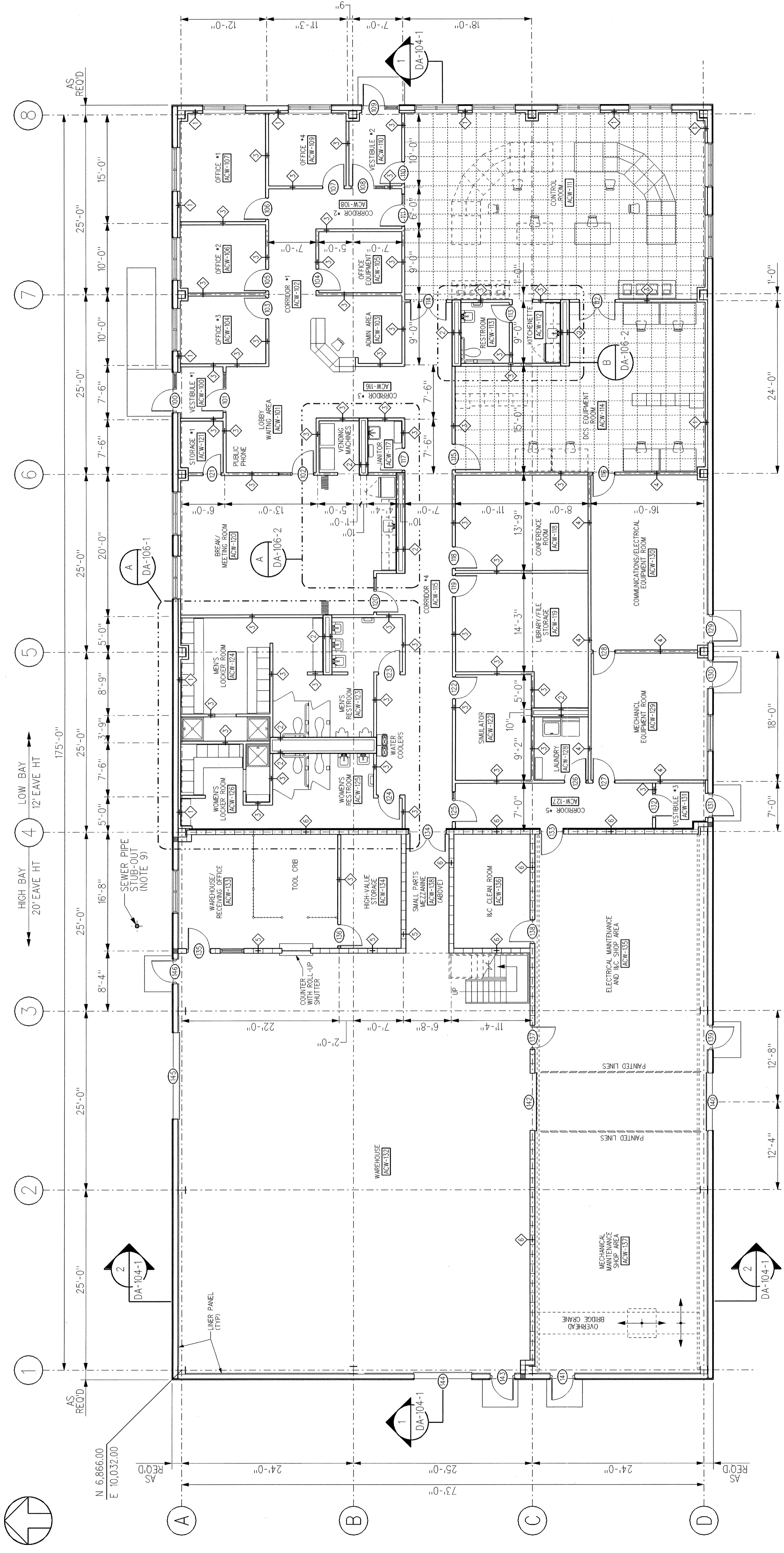

FLOOR PLAN
SCALE: 1/8"=1'-0"
(13,440-SF)

- NOTES**
1. THE ADMIN/CONTROL/WAREHOUSE BUILDING HAS BEEN DESIGNED FOR CONSTRUCTION AS A PRE-ENGINEERED, PRE-FABRICATED BUILDING SYSTEM AND AS SUCH ALL RELATED STRUCTURAL DIMENSIONS ARE APPROXIMATE AND MAY BE CHANGED, WITH ENGINEER APPROVAL, TO ALLOW THE USE OF STANDARD BUILDING FRAMES AND COMPONENTS.
 2. PRE-ENGINEERED BUILDING DESIGN SHALL BE IN ACCORDANCE WITH THE PROJECT SPECIFICATIONS, INCLUDING THE LOAD CONDITIONS AND DESIGN REFERENCES/CODE DESCRIBED IN ICB 2000.
 3. SEE SHEET DA-100-2 FOR ARCHITECTURAL SYMBOLOLOGY AND GENERAL NOTES.
 4. SEE SHEET DA-100-3 FOR ARCHITECTURAL ABBREVIATIONS.
 5. SEE SHEET DA-100-4 FOR ARCHITECTURAL MATERIALS AND FINISHES.
 6. FLOOR SLAB ELEVATION SHOWN (EL 100'-0") IS THE NOMINAL ELEVATION. ACTUAL ELEVATION IS 5052'-0".
 7. SEE SHEET DA-108-1 - DOOR AND FRAME SCHEDULE - FOR INDIVIDUAL DOOR OPENING (DO) DIMENSIONS.
 8. SEE SHEET DA-108-2 - ROOM FINISH AND WINDOW SCHEDULE - FOR INDIVIDUAL WINDOW OPENING (WO) DIMENSIONS AND ARCHITECTURAL FINISH MATERIALS.
 9. SEE SHEET 100545-DY-120 - SANITARY SEWER SYSTEM PLAN - FOR EXACT LOCATION AND ADDITIONAL INFORMATION.

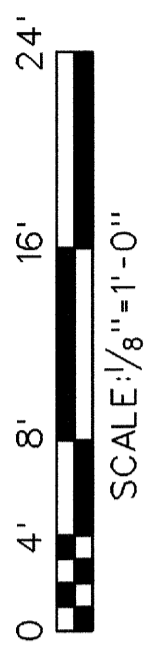

Shaw Stone & Webster, Inc. IOWA, UTAH	
CURRENT-CREEK POWER PROJECT ADMIN/CONTROL/WAREHOUSE BUILDING FLOOR PLAN	
PROJ: 100545 PL: 100545-DA-101-1 DATE: 7-24-2004 ENG: <i>[Signature]</i> DR: <i>[Signature]</i> APPROVAL:	SHEET 5 of 16 SCALE: 1/8"=1'-0" REV. B

NO.	DATE	REVISION	BY	CHK	APP	NO.	DATE	REVISION	BY	CHK	APP
1	12-19-03	CLIENT REVIEW	MLN	GMP							

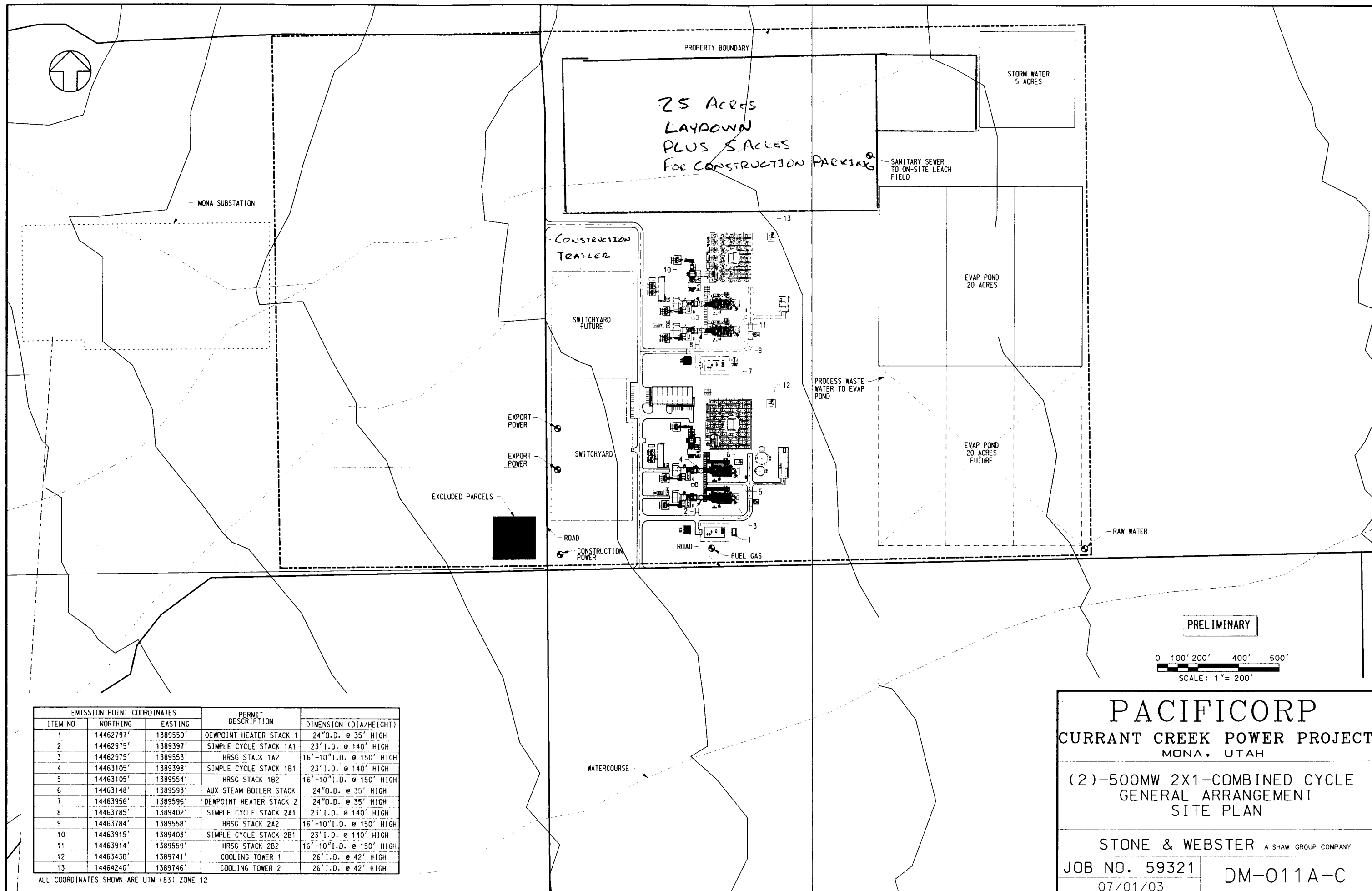

ITEM NO	EMISSION POINT COORDINATES		PERMIT DESCRIPTION	DIMENSION (DIA/HEIGHT)
	NORTHING	EASTING		
1	14462797'	1389559'	DEWPOINT HEATER STACK 1	24"O.D. @ 35' HIGH
2	14462975'	1389397'	SIMPLE CYCLE STACK 1A1	23' I.D. @ 140' HIGH
3	14462975'	1389553'	HRSG STACK 1A2	16'-10" I.D. @ 150' HIGH
4	14463105'	1389398'	SIMPLE CYCLE STACK 1B1	23' I.D. @ 140' HIGH
5	14463105'	1389554'	HRSG STACK 1B2	16'-10" I.D. @ 150' HIGH
6	14463148'	1389593'	AUX STEAM BOILER STACK	24"O.D. @ 35' HIGH
7	14463956'	1389596'	DEWPOINT HEATER STACK 2	24"O.D. @ 35' HIGH
8	14463785'	1389402'	SIMPLE CYCLE STACK 2A1	23' I.D. @ 140' HIGH
9	14463784'	1389558'	HRSG STACK 2A2	16'-10" I.D. @ 150' HIGH
10	14463915'	1389403'	SIMPLE CYCLE STACK 2B1	23' I.D. @ 140' HIGH
11	14463914'	1389559'	HRSG STACK 2B2	16'-10" I.D. @ 150' HIGH
12	14463430'	1389741'	COOLING TOWER 1	26' I.D. @ 42' HIGH
13	14464240'	1389746'	COOLING TOWER 2	26' I.D. @ 42' HIGH

ALL COORDINATES SHOWN ARE UTM (83) ZONE 12

PACIFICORP
CURRENT CREEK POWER PROJECT
 MONA, UTAH

(2)-500MW 2X1-COMBINED CYCLE
 GENERAL ARRANGEMENT
 SITE PLAN

STONE & WEBSTER A SHAW GROUP COMPANY

JOB NO. 59321 DM-011A-C
 07/01/03

APPENDIX D

**CONCEPTUAL PROCESS FLOW DIAGRAMS AND WATER
BALANCE**

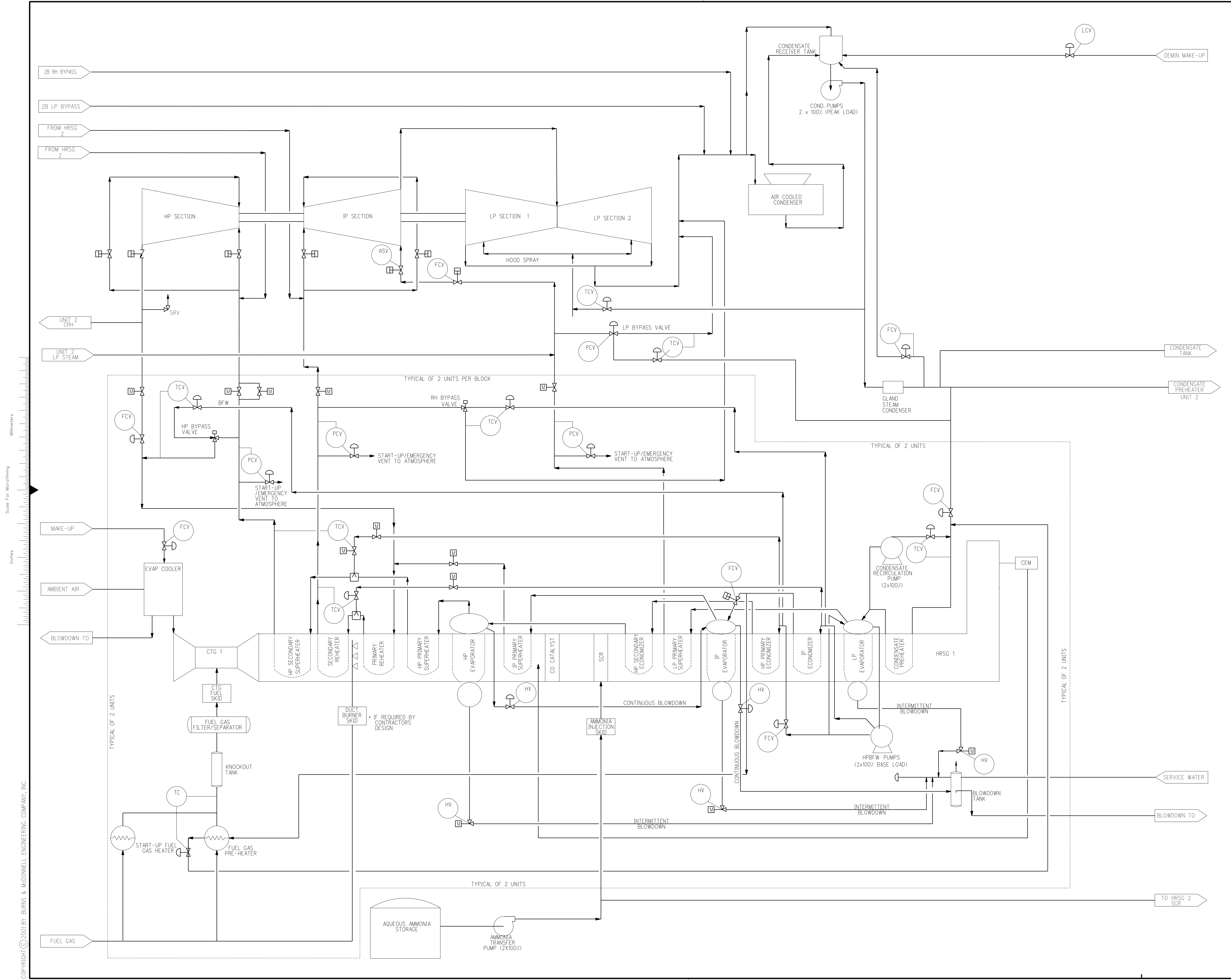

no.	date	by	revision

100% CAPACITY IS 100% "PEAK" BLOCK CAPACITY OR DESIGN DUTY UNLESS NOTED OTHERWISE



Burns & McDonnell
SINCE 1898

date	detailed
designed	checked

**PACIFICORP
CURRENT CREEK
POWER PROJECT
BLOCK 2**

**CONCEPTUAL PROCESS
FLOW DIAGRAM**

project	contract	
drawing	rev.	
FD-1	- A	
sheet	of	sheets
File FD-01.DGN /10-19-2004 13:34 /		

COPYRIGHT © 2001 BY BURNS & MCDONNELL ENGINEERING COMPANY, INC.

Scale For Microfilming
Meters
Inches

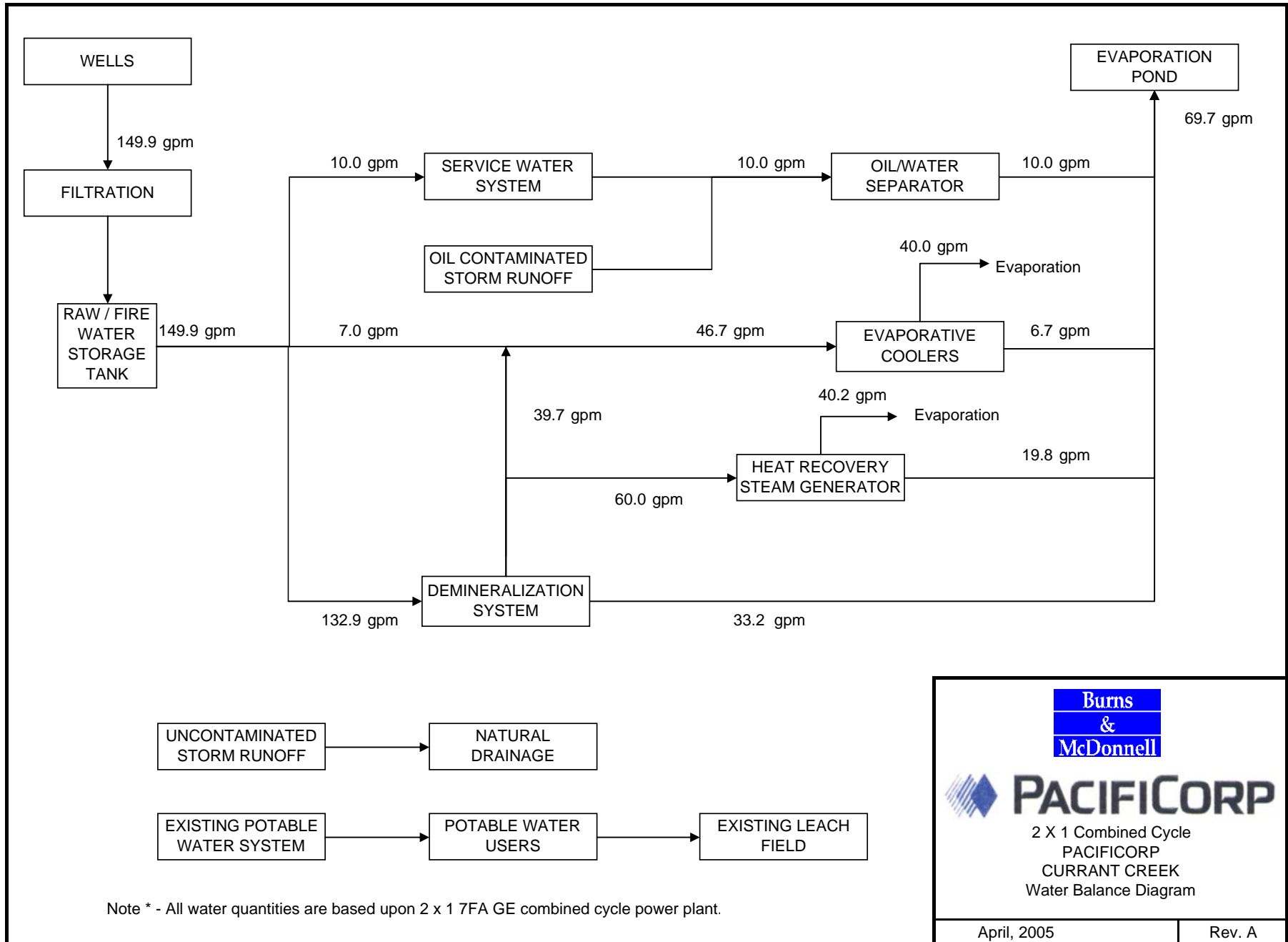

Burns & McDonnell

 2 X 1 Combined Cycle
 PACIFICORP
 CURRANT CREEK
 Water Balance Diagram

April, 2005	Rev. A
-------------	--------

APPENDIX E

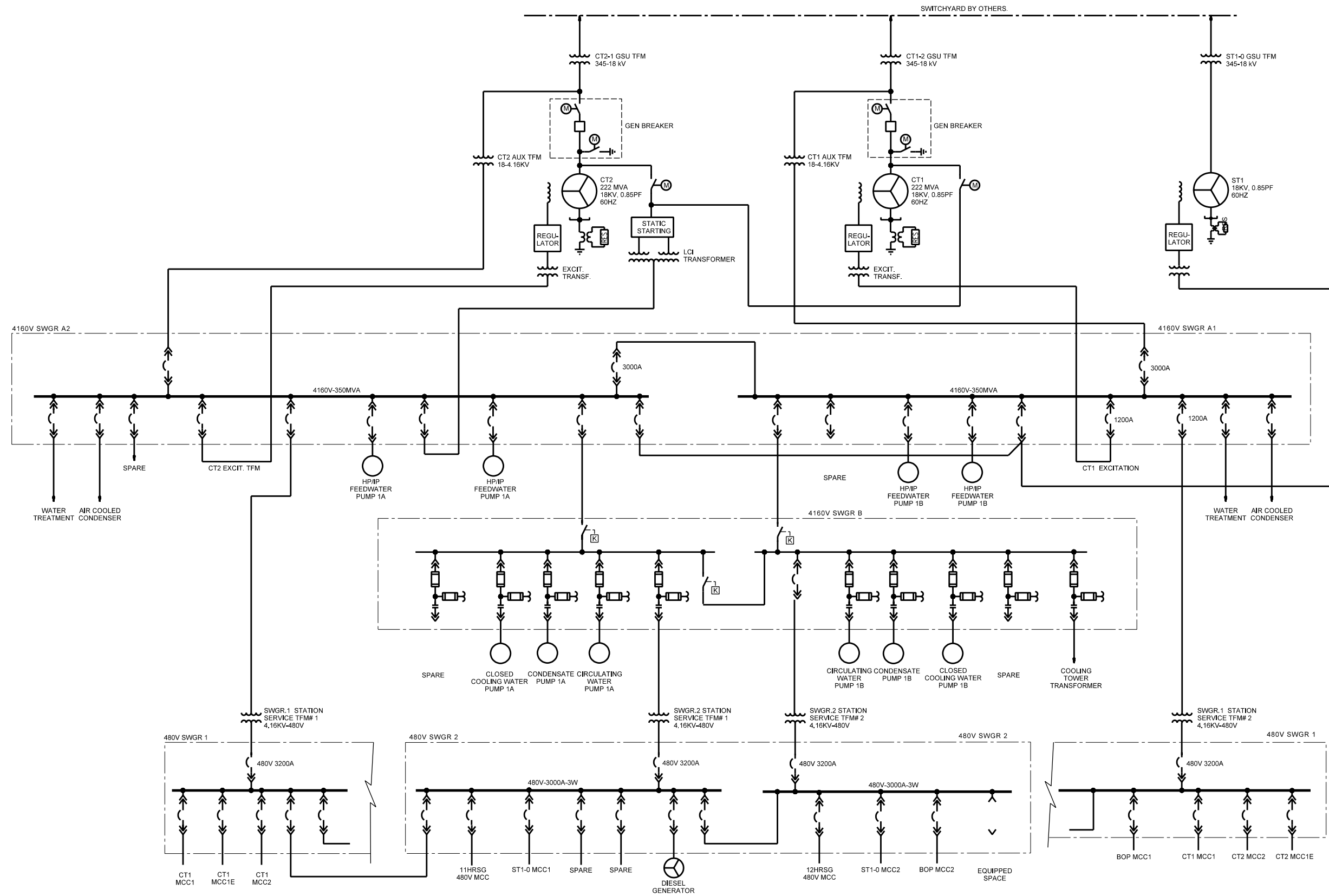
CONCEPTUAL ONE-LINE DIAGRAMS



NOTES:

- ONLINE TO BE REVISED TO REFLECT PROPOSED COMBUSTION TURBINE.



date **APRIL 20, 2005**
 designed **D. STEPHENS**

PACIFICORP
 POWER SUPPLY
CURRENT - CREEK
 2 x 1 COMBINED CYCLE
 CONCEPTUAL ONE-LINE DIAGRAM

project	38849
contract	
rev.	2
SKE-1	

APPENDIX F

PACIFICORP - “Material Specification ZS 001-2004, Substation Equipment – Power Transformer All Ratings”

Material Specification

**Substation Equipment—Power Transformer,
All Ratings**

Standards Engineering Department

Date: 31 Oct 07

© 2007 by PacifiCorp. All rights reserved.

This page is left blank intentionally.

Contents

SECTION	PAGE
1 Scope	1
2 References	1
2.1 Industry Publications	1
2.2 PacifiCorp Publications	1
3 General	1
3.1 Application Information	1
3.2 Authorized Material Specification	2
4 Basic Design Requirements	2
4.1 Codes, Standards and Terminology	2
4.2 Type	2
4.3 Cooling Class and Rated Capacity	2
4.4 Elevation	2
4.5 Ambient Temperature	3
4.6 Phase Designation	3
4.7 Impedances	3
4.8 Transformer Bank and Parallel Operation	3
4.9 Transformer Loading	3
4.10 Flux Density	4
4.11 Winding Design and Insulation Materials	5
4.12 Short-Circuit Withstand	6
4.13 Wind and Seismic Withstand	6
4.14 Design for Shipment	6
4.15 Contaminated-Environment Protection	6
4.16 Streaming Electrification	6
4.17 Core	6
5 Cooling Equipment	7
5.1 Winding Hot-Spot Control	7
5.2 Radiators or Coolers	9
5.3 Cooling Fans	10
5.4 Circulating Pumps	10
5.5 Fan and Pump Control	10
5.6 Auxiliary Relay	11
5.7 Location of Control Devices	11

SECTION	PAGE
6 Load Tap Changing Equipment	11
6.1 Approved Load Tap Changers and Control	11
6.2 Regulation Range	11
6.3 Listed Tap Positions	12
6.4 Paralleling Equipment	12
6.5 Directional Lockout	12
6.6 Provisions for Remote Control and Indication	12
6.7 Adjustable Time Delay	13
6.8 Line Drop Compensator Current Transformers	13
6.9 Control Voltage Transformer	14
6.10 Control Voltage Electrical Isolation	14
6.11 Loss of Control Voltage	14
6.12 Pressure Relief Device	14
6.13 Rapid-Pressure-Rise Relay	14
6.14 Oil Level Indication and Protection	15
6.15 Top-Oil Resistance Temperature Detector	15
6.16 Location of Control Devices	15
6.17 Tap-Winding Lead Connections	15
7 Bushings and Surge Arresters	15
7.1 Bushings	15
7.2 Surge Arresters	16
8 Other Construction Requirements	17
8.1 Accessory Location	17
8.2 De-energized Tap Changer(s), Reconnection Switch(es), and Reconnection Terminal Board(s)	18
8.3 Surge Arrester Ground Connections	19
8.4 Y-Winding Requirements	19
8.5 Current Transformers	20
8.6 Auxiliary Equipment Voltages	23
8.7 Wiring	23
8.8 Control Compartment	24
8.9 Core Ground	25
8.10 Insulating Oil	25
8.11 Oil Preservation System	25
8.12 Tank Design	27
8.13 Valve Requirements	28
8.14 Valves and Field Oil-Filling Procedure for Transformer with Conservator System	28
8.15 Gaskets and Internal Washers	31

SECTION	PAGE
8.16 Welds	31
8.17 Exposed Fasteners and Hardware	31
8.18 Fall Arrest Equipment Base Plate	31
8.19 Ladder	31
8.20 Safety Railing Equipment	32
9 Other Auxiliary Protection Device Requirements	36
9.1 Auxiliary Device Contacts	36
9.2 Indicating Lights	36
9.3 Oil Level Indication and Protection	36
9.4 Main Tank Pressure Relief Device(s)	37
9.5 Main Tank Rapid-Pressure-Rise Relay	37
9.6 Gas Detector Relay	38
9.7 Alarm Monitor	38
10 Nameplate Requirements	39
10.1 General	39
10.2 Main Transformer Nameplate	39
10.3 Load Tap Changer Nameplate	40
10.4 Valve Identification and Location Nameplate	40
10.5 Field Oil-Filling Procedure Nameplate	40
11 Finish Requirements	41
11.1 Tank Exterior Finish and Porcelain Color	41
11.2 Tank Interior Finish	41
12 Special Test Requirements, Measurements, and Calculations	41
12.1 General	41
12.2 Test Sequence	41
12.3 Surge Protection Devices	41
12.4 Test Bushings	41
12.5 Dissolved Gas Analysis	42
12.6 Gas Collection Tests	42
12.7 Positive-Sequence Impedance	42
12.8 Zero-Sequence Impedance	43
12.9 No-Load Loss and Excitation Current	43
12.10 Loss Compliance	43
12.11 Insulation Resistance	43
12.12 Power-Factor and Excitation-Current Tests	43
12.13 Auxiliary Wiring	44
12.14 Temperature Tests	44
12.15 Test Data Required for Temperature Monitor	45

SECTION	PAGE
12.16 Lightning Impulse	45
12.17 Switching Impulse	45
12.18 Induced Voltage Tests and Partial Discharge Measurement	46
12.19 Short-Circuit Testing	46
12.20 Audible Sound Level	46
12.21 Tap Changer Continuity Test	46
12.22 Frequency Response Analysis	47
12.23 Unintentional Core Ground	47
13 Technical Documentation	47
13.1 Technical Documentation for Approval	47
13.2 Final Technical Documentation	48
13.3 Technical Documentation Description	48
14 Shipping Requirements	49
14.1 Air-filled or Oil-filled	49
14.2 Factory Assembly and Component Location Marking	50
14.3 Shipping Dimensions and Weight	50
14.4 Notice of Shipment	50
14.5 Impact Recorders	50
14.6 Rail Shipment	50
14.7 Supplier Representative	51
15 Other Inspection Requirements	51
15.1 Design Review	51
15.2 Quality Surveillance	51
15.3 Field Engineer	52
16 Evaluation	52
16.1 Product Evaluation	52
16.2 Loss Evaluation Method	52
16.3 Loss Cost Multipliers	52
16.4 Loss Penalty	53
16.5 Shipping Cover	53
16.6 Horizontal Shipment	53
16.7 Method of Shipment	53
17 Additional Transformer-Specific Requirements	54
17.1 Equipment Identification and Order Requirements	54
17.2 Loss Cost Multipliers	55
17.3 Contaminated Environment Protection	56
17.4 Service Class	56

SECTION	PAGE
17.5 Design Form	56
17.6 Elevation	56
17.7 Ambient Temperature	56
17.8 Phase Designation	56
17.9 Winding Type	56
17.10 Winding Designation	57
17.11 Cooling Class	57
17.12 Capacity Ratings	57
17.13 Voltage and Surge Arrester Ratings	58
17.14 Load Tap Changing Equipment	61
17.15 Impedance(s)	62
17.16 Bank Operation and Parallel Operation	62
17.17 Polarity or Angular Displacement	63
17.18 Bushing BIL Requirements	64
17.19 Surge Arrester Discharge Counters	65
17.20 Current Transformers	65
17.21 Resistance Temperature Detector	65
17.22 Auxiliary Equipment Voltages	66
17.23 Oil-Level Protection	66
17.24 Main Tank Rapid-Pressure-Rise Relay	66
17.25 Alarm Monitor	67
17.26 Core Ground	67
17.27 Oil Preservation System	67
17.28 Additional Test Requirements	67
17.29 Audible Sound Level	68
17.30 Core-Form Clamping System Tightness	68
17.31 Ladder	68
17.32 Safety Railing Equipment	68
17.33 Winding Connections for Shipment	69
17.34 Tank Contents for Shipment	69
18 Issuing Department	69

FIGURES	PAGE
Figure 1 - Accessory Location	18
Figure 2 - Y-winding CT Arrangement	20
Figure 3 - Typical Connection Diagram for CT Terminal Blocks	21
Figure 4 - Typical CT Location Diagram	22
Figure 5 - Valve Location Schematic Drawing	30
Figure 6 - Safety Railing System Overview	34
Figure 7 - Safety Railing Post and Kickboard Detail	35
Figure 8 - Three-Phase Transformer Angular Displacement	63

TABLES	PAGE
Table 1 - Bushing Terminal Stud Sizes	16
Table 2 - Station-Class Arresters	17
Table 3 - Initial Valve Positions	31
Table 4 - Dissolved Gas Limits	42
Table 5 - Qualitrol Temperature Monitor, Table of Temperature Test Data	45
Table 6 - Transformer Capacity Ratings	57
Table 7 - Transformer Voltage and Surge Arrester Ratings	59
Table 8 - De-energized Tap Voltage Ratings (kV, L-L)	60
Table 9 - Reinhausen RMV-II	61
Table 10 - Waukesha UZD	61
Table 11 - Reinhausen VR	62
Table 12 - Transformer Impedance(s)	62
Table 13 - Bushing BIL Requirements	64
Table 14 - Bushing Current Transformers	65
Table 15 - Y-winding Internal Current Transformers	65
Table 16 - Optional Tests for Class I Transformer	67
Table 17 - Optional Tests for Class II Transformer	68

Substation Equipment—Power Transformer, All Ratings

1 Scope

This material specification states the requirements for substation power transformers of all ratings purchased by PacifiCorp.

2 References

The following publications shall be used in conjunction with this material specification, and form a part of this material specification to the extent specified herein. When a referenced publication is superseded by an approved revision, the revision shall apply.

2.1 Industry Publications

Referenced industry publications are:

ANSI C57.12.10, *Standard for Transformers 230 kV and Below...through 60000 / 80000 / 100000 kVA*

IEEE C2, *National Electrical Safety Code*

IEEE C57.12.00, *Standard General Requirements for Liquid-Immersed Distribution, Power, and Regulating Transformers*

IEEE C57.12.70, *Standard Terminal Markings and Connections for Distribution and Power Transformers*

IEEE C57.12.90, *Standard Test Code for Liquid-Immersed Distribution, Power, and Regulating Transformers and Guide for Short-Circuit Testing of Distribution and Power Transformers)*

IEEE C57.91, *Guide for Loading Mineral-Oil-Immersed Transformers*

NEMA TR1, *Transformers, Regulators, and Reactors*

NFPA 70, *National Electrical Code*

2.2 PacifiCorp Publications

Referenced PacifiCorp publications are:

Material Specification ZS 061, *Electrical Equipment—Insulating Oil*

Material Specification ZS 065, *Wind, Ice and Seismic Withstand*

Material Specification ZS 066, *Contaminated-Environment Protection*

3 General

3.1 Application Information

This material specification states both the general requirements for transformers and the transformer-specific requirements that vary depending on the installation and intended use (see Section 17 of this document, *Additional Transformer-Specific Requirements*).

**MATERIAL SPECIFICATION
Substations and High-
Voltage Equipment**

© 2007 by PacifiCorp. All rights reserved.

Engineer (M. Weisensee):

Standards Manager (G. Lyons):

MW
GL

**Substation Equipment—
Power Transformer, All
Ratings**



31 Oct 07

ZS 001
Page 1 of 70

ZS 001

3.2 Authorized Material Specification

This material specification is not considered valid until each page contains the approval signatures (or initials) of the persons named in the title blocks, and Section 17 of this document has been completed.

4 Basic Design Requirements

4.1 Codes, Standards and Terminology

Except as required otherwise by this material specification, the transformer specified herein shall be furnished in complete accordance with the latest applicable industry codes; ANSI, IEEE, and NEMA standards; and PacifiCorp standards and material specifications in effect on the date of invitation to bid.

In addition, the requirements of ANSI C57.12.10, which specifically apply only to a certain range of transformer ratings, shall nevertheless be considered applicable to all transformer ratings wherever reasonable and practical. The supplier shall advise PacifiCorp of any exceptions where such requirements will not apply to the subject transformer.

All values of voltage and current in this material specification are AC RMS unless otherwise specified.

In accordance with IEEE C57.12.70, this document uses H to designate the high-voltage winding, X to designate the low-voltage winding, and Y to designate the tertiary winding, as applicable.

In accordance with IEEE C57.12.00, this document uses the term Class I to designate a transformer with the H-terminals rated for a nominal system voltage of 69 kV or below, and Class II to designate a transformer with the H-terminals rated for a nominal system voltage of 115 kV or above.

4.2 Type

The transformer shall be outdoor, 60-hertz, oil-immersed, 65°C average winding temperature rise, 80°C hot-spot winding temperature rise, 65°C top-oil temperature rise, suitable for the class of service specified in Section 17.4 of this document, and core-form or shell-form as specified in Section 17.5 of this document.

4.3 Cooling Class and Rated Capacity

The cooling class shall be as specified in Section 17.11 of this document. The rated capacity shall be as specified in Section 17.12 of this document.

4.4 Elevation

Unless otherwise specified in Section 17.6 of this document, the transformer shall be rated for elevations up to 3300 feet. For elevations above 3300 feet, or above the elevation speci-



ZS 001
Page 2 of 70

31 Oct 07

**Substation Equipment—
Power Transformer, All
Ratings**

**MATERIAL SPECIFICATION
Substations and High-
Voltage Equipment**

© 2007 by PacifiCorp. All rights reserved.

Engineer (M. Weisensee): *MW*
Standards Manager (G. Lyons): *GL*

fied in Section 17.6 of this document, any required derating of the dielectric strength shall not exceed the IEEE C57.12.00 correction factor of 1.0% for each 330 feet of elevation increase, and any required derating of the kVA rating shall not exceed the IEEE C57.91 correction factors of 0.4% (self-cooled rating) and 0.5% (forced-cooled ratings) for each 330 feet of elevation increase.

4.5 Ambient Temperature

Unless otherwise specified in Section 17.7 of this document, the transformer shall be rated for an ambient temperature range of -30°C daily minimum to +40°C daily peak, with a daily average of +30°C.

4.6 Phase Designation

The phase of the transformer shall be single-phase or three-phase, as specified in Section 17.8 of this document.

4.7 Impedances

Transformer impedances shall be selected by the supplier or shall be in accordance with specific PacifiCorp requirements, as specified in Section 17.15 of this document. The total impedances used for the short-circuit-withstand design of the transformer shall be the transformer impedances only, without considering any benefit of system impedances.

4.8 Transformer Bank and Parallel Operation

The following requirements for transformer bank and parallel operation shall apply on all de-energized and load tap positions, with impedances on all tap positions in compliance with the IEEE tolerance.

If the transformer is single-phase, and if specified in Section 17.16.1 of this document, the transformer shall be suitable for operation in a three-phase bank with the identified similar transformers. Also, if specified in Section 17.16.2 of this document, the three-phase bank including the transformer shall be suitable for H-terminal to X-terminal operation in parallel with the identified similar three-phase transformer(s) or three-phase transformer bank(s).

If the transformer is three-phase, and if specified in Section 17.16.2 of this document, the transformer shall be suitable for H-terminal to X-terminal operation in parallel with the identified similar three-phase transformer(s) or three-phase transformer bank(s).

4.9 Transformer Loading

4.9.1 Normal Three-Winding Operation

If a three-winding transformer or a three-winding autotransformer is specified in Section 17.9 of this document, with the Y-terminals specified to be brought out (see

**MATERIAL SPECIFICATION
Substations and High-
Voltage Equipment**

© 2007 by PacifiCorp. All rights reserved.

Engineer (M. Weisensee): *MW*
Standards Manager (G. Lyons): *GL*

**Substation Equipment—
Power Transformer, All
Ratings**



31 Oct 07

ZS 001
Page 3 of 70

ZS 001

Section 17.13 of this document), the transformer shall be suitable for normal simultaneous three-winding operation provided that the rated capacity of any set of terminals is not exceeded, and that the arithmetic sum of the output loads does not exceed the rated capacity of the input terminals (for an autotransformer, the input terminals shall be assumed to be the H-terminals).

4.9.2 Loading Guide Application

The complete transformer, including the windings, the cooling system, and all external and internal auxiliary components and capabilities (such as bushings, current transformers, leads, tap changers, oil expansion, pressure in sealed units, stray flux heating, etc.) shall be suitable for operation in accordance with IEEE C57.91. It is the intent of this requirement that no transformer auxiliary component or capability shall have or cause greater loss of life, or result in more restrictive limitations on transformer loading, than the loss of life and loading limitations associated with the transformer windings and cooling system.

4.10 Flux Density

4.10.1 General Transformer Requirement

With the transformer energized at no-load on the nominal rated de-energized tap(s), and the neutral LTC tap if applicable, at 100% rated voltage, the maximum flux density in the core shall not exceed 1.7 Tesla.

4.10.2 LTC Autotransformer Requirement

With the transformer energized at no-load on the nominal rated de-energized tap(s), at 100% rated voltage, the maximum flux density in the core shall be determined as follows based on the location of the LTC.

1. If the LTC is located at the bottom end of the series winding (above the low-voltage line terminals), the maximum flux density shall not exceed 1.7 Tesla on the neutral LTC tap.
2. If the LTC is located in series with the low-voltage line, the maximum flux density shall not exceed 1.7 Tesla.
3. If the LTC is located at the neutral end of the common winding, the maximum flux density shall not exceed 1.7 Tesla on any LTC tap. For this design, if the tertiary (Y) terminals are specified to be brought out (see Section 17.13 of this document), compensation shall be furnished to maintain constant tertiary winding voltage as taps are changed across the entire LTC range.

4.10.3 Generator Step-Up Transformer Requirement

With the transformer energized at no-load, at 100% rated tap voltage, the maximum flux density in the core shall not exceed the value determined by the following formula:



$$\text{MFD} = 1.7 - (\text{IZ} - 12.7)(0.0093) \text{ Tesla}$$

where

MFD = maximum flux density on any de-energized tap

IZ = percent impedance at the respective rated tap voltage and the rated maximum forced-cooled capacity

This formula is valid for IZ of 12.7% or greater. For values of IZ below 12.7%, the maximum flux density shall be 1.7 Tesla.

4.11 Winding Design and Insulation Materials

For a three-phase core-form transformer with a self-cooled rating of 10000 kVA or above, or a single-phase core-form transformer with a self-cooled rating of 3333 kVA or above, the winding design shall be circular. For a core-form transformer with a capacity rating below those specified above, the winding design shall be circular or rectangular.

For all transformers, the following requirements shall apply:

1. All conductor material shall be copper.
2. All conductor insulation shall be EHV-Weidmann.
3. All insulation materials shall be thermally upgraded (suitable for continuous operation at 120°C).
4. All conductor paper insulation on CTC (continuously transposed conductor) shall be Denisson paper. At a minimum, the outer layer of paper insulation on all strap copper conductor shall be Denisson paper.
5. When using CTC that is fully insulated with paper, the transformer supplier shall design the radial cooling ducts to have a minimum radial spacer thickness of 5mm.
6. When using netting type CTC, the transformer supplier shall design the radial cooling ducts to have a minimum radial spacer thickness of 3 mm.
7. Each clamping ring shall be one-piece, with no reduction in the thickness of the ring in the core window.
8. The winding design shall not utilize internal surge protection devices.
9. The dielectric stress at any location in the core-and-coil assembly shall not exceed 2.65 kV/mm with the transformer energized at 100% rated voltage on the maximum-stress tap position(s).
10. All brazed connections in CTC shall be strand-to-strand, i.e. each strand shall be individually brazed.
11. Formvar insulated conductors are not acceptable, except in CTC.
12. Phelps-Dodge CTC is not acceptable.
13. For a rectangular-design transformer, the allowable impedance change after short-circuit testing shall be 2%, the same as specified in IEEE C57.12.90 for a circular-design transformer.
14. The conductor ratio, based on individual un-insulated strands, shall not exceed 6.5 to 1.
15. When layer winding is used, the radial build shall be a minimum of 10 mm. Only one conductor in the radial direction is allowed unless the cable used is CTC.

**MATERIAL SPECIFICATION
Substations and High-Voltage Equipment**

© 2007 by PacifiCorp. All rights reserved.

Engineer (M. Weisensee):

Standards Manager (G. Lyons):

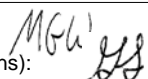

**Substation Equipment—
Power Transformer, All
Ratings**



31 Oct 07

ZS 001
Page 5 of 70

ZS 001

All winding supports and supports in the area of high-voltage field shall have a minimum compression strength parallel-to-grain of 7,800 psi and compression strength perpendicular-to-grain of 1,400 psi. Preference will be given to products having compression strength exceeding 10,000 psi, such as TX and T-IV boards. The supplier shall state in the proposal the type of winding insulation, blocking and lead support being used within the transformer.

4.12 Short-Circuit Withstand

All windings subject to inward radial buckling shall be designed to withstand “free” (unsupported) buckling in addition to “forced” (supported) buckling. The control of inward radial forces shall not depend upon bracing to the core. It is preferred that epoxy-bonded conductors be used for both the inner and outer windings. Short-circuit calculations shall be based on 105% of the nominal rated transformer voltage. Upon completion of the transformer design, the supplier shall furnish to PacifiCorp the calculated free and forced buckling forces and the withstand values.

When layer windings are used, each layer shall be designed for “free” buckling independent of the other layers. The radial build of any layer shall be at least 0.50 inches. Multiple strap conductors in the radial direction are not acceptable. Epoxy-bonded cable is required for windings subject to inward radial buckling.

4.13 Wind and Seismic Withstand

The wind and seismic withstand capability of the transformer shall be in accordance with PacifiCorp Material Specification ZS 065.

4.14 Design for Shipment

Regardless of the method (truck or rail; see Section 16.7 of this document) to be employed for shipment of the transformer from the factory to the specified destination, the transformer shall be designed for shipment by rail. This requirement will ensure that the transformer has sufficient strength for possible later reshipment by rail.

4.15 Contaminated-Environment Protection

If specified in Section 17.3 of this document, the transformer shall be furnished in accordance with the contaminated-environment protection requirements of PacifiCorp Material Specification ZS 066. (Note that the exposed fasteners and hardware on *all* transformers shall meet the requirements of Section 8.17 of this document.)

4.16 Streaming Electrification

The transformer shall be designed so that streaming electrification is minimized and does not affect transformer operation or reliability within the specified temperature range.

4.17 Core

Every core step shall be supported by inserting a non-conductive material between the core step and the base bar that connects the core clamps. Every core step shall be supported at



the ends. Bolting through the yokes is not acceptable. Use of a “no-scrap” type core design is not acceptable.

5 Cooling Equipment

5.1 Winding Hot-Spot Control

The cooling equipment shall be controlled from winding hot-spot temperature. Equipment to simulate winding hot-spot temperature(s) and control the cooling equipment shall be furnished as specified below. Necessary current transformer(s) shall be in addition to the current transformers specified in Section 17.20 of this document.

5.1.1 Main Tank Top-Oil Resistance Temperature Detector

A Qualitrol resistance temperature detector (RTD), with associated thermowell, shall be furnished to detect the transformer main tank top-oil temperature. The RTD shall be 10-ohm copper or 100-ohm platinum as specified in Section 17.21.1 of this document, with Qualitrol connector and shielded cable.

5.1.2 Ambient Temperature Resistance Temperature Detector

A Qualitrol resistance temperature detector (RTD) shall be furnished to detect the ambient temperature near the transformer. The RTD shall be 10-ohm copper or 100-ohm platinum as specified in Section 17.21.2 of this document, with sun shield, and with Qualitrol connector and shielded cable. The RTD shall be mounted on the underside of the control compartment in a location that will not conflict with workable access to the compartment bottom drill plate.

5.1.3 Current Transformer(s)

Qualitrol clamp-on current transformer(s), input range 0–10 A, shall be furnished for winding hot-spot temperature simulation as specified below. The current transformer secondary leads shall be wired to terminal blocks in the control compartment and connected to the temperature monitor.

The specific current transformer(s) required are as follows:

1. For a two-winding transformer, or a three-winding transformer with the tertiary buried, one current transformer shall be furnished in the low-voltage winding for simulation of the low-voltage winding hot-spot temperature.
2. For a three-winding transformer with the tertiary terminals brought out, three current transformers shall be furnished, one in each winding, for simulation of the hot-spot temperature of each winding. The associated temperature monitor output relays will be operated from the hottest of the three winding hot-spot temperatures.

ZS 001

5.1.4 Temperature Monitor

A Qualitrol temperature monitor shall be furnished for indication of the top-oil temperatures in the main tank and the LTC oil-filled compartment (if applicable) and the winding hot-spot temperature(s), and for control of the cooling equipment. All temperature monitor input and output terminals, except for terminals connecting to the RTD(s), shall be wired to terminal blocks in the control compartment and connected to the current transformer(s) and cooling equipment.

It is preferred that the temperature monitor be flush-mounted on a panel in the control compartment; the monitor shall be readily visible when the compartment door is open (the monitor shall not be located behind a hinged panel or other concealment). If necessary, the monitor may be mounted near the control compartment in a separate Qualitrol enclosure (NEMA 3R), equipped with a 120 VAC space heater.

If the main tank top-oil RTD is specified to be 10-ohm copper (see Section 17.21 of this document), the temperature monitor shall be Qualitrol model IED509-00009908 (panel-mounted in the control compartment), or IED509-00009909 (mounted in a separate enclosure).

If the main tank top-oil RTD is specified to be 100-ohm platinum (see Section 17.21 of this document), the temperature monitor shall be Qualitrol model IED509-00010200 (panel-mounted in the control compartment), or IED509-00010201 (mounted in a separate enclosure).

Detailed temperature monitor requirements are as follows:

1. The monitor power supply will be DC, from PacifiCorp's substation battery.
2. The eight output control/alarm contacts shall be wired to terminal blocks and connected as follows:
 1. Start first stage of forced-cooling equipment
 2. Start second stage of forced-cooling equipment
 3. Future use
 4. Activate PacifiCorp's winding hot-spot temperature alarm
 5. Initiate winding hot-spot temperature trip of PacifiCorp's switching device
 6. Activate PacifiCorp's main tank top-oil temperature alarm
 7. Activate PacifiCorp's LTC differential top-oil temperature alarm (if applicable)
 8. Future use
3. The diagnostics alarm contact shall be wired to a terminal block.
4. The RS-485 communication terminals shall be wired to a terminal block.
5. The four mA outputs shall *not* be wired to terminal blocks.



5.1.5 Temperature Monitor Settings and Cooling Equipment Control Connections

The temperature monitor settings and cooling equipment control connections required for the most common transformer cooling classes are as specified below. Note that the actual values of the temperature settings will be selected by PacifiCorp; the temperatures specified below are the normal values used for most applications.

1. For all transformers, one temperature monitor output relay operated from the main tank top-oil temperature will be used to activate PacifiCorp’s alarm (normally at 90°C).
2. For a transformer with a self-cooled rating and one forced-cooled rating, three temperature monitor output relays operated from the winding hot-spot temperature (or the hottest of the three winding hot-spot temperatures) will be utilized: one shall be connected by the supplier to start the forced-cooling equipment (normally at 80°C); one will be used to activate PacifiCorp’s alarm (normally at 110°C); and one will be used to trip PacifiCorp’s switching device (normally at 130°C).
3. For a transformer with a self-cooled rating and two forced-cooled ratings, four temperature monitor output relays operated from the winding hot-spot temperature (or the hottest of the three winding hot-spot temperatures) will be utilized: one shall be connected by the supplier to start the first stage of forced-cooling equipment (normally at 75°C); one shall be connected by the supplier to start the second stage of forced-cooling equipment (normally at 80°C); one will be used to activate PacifiCorp’s alarm (normally at 110°C); and one will be used to trip PacifiCorp’s switching device (normally at 130°C).
4. For a transformer with two forced-cooled ratings (no self-cooled rating), four temperature monitor output relays operated from the winding hot-spot temperature (or the hottest of the three winding hot-spot temperatures) will be utilized: one shall be connected by the supplier to start the first stage of forced-cooling equipment upon energization of the transformer; one shall be connected by the supplier to start the second stage of forced-cooling equipment (normally at 80°C); one will be used to activate PacifiCorp’s alarm (normally at 110°C); and one will be used to trip PacifiCorp’s switching device (normally at 130°C).

5.2 Radiators or Coolers

The radiators or coolers shall be completely supported by their attachment to the transformer tank; external supports are not acceptable. The radiators or coolers shall be removable and shall be equipped with lifting eyes. The radiators or coolers shall be filled with 5-10 psi of dry nitrogen air with a nitrogen pressure valve and gauge, and a protective cover if removed for shipment. The supplier shall furnish suitable valves on the transformer side of the radiator or cooler mounting flanges, and the radiators or coolers shall be furnished with pipe taps and plugs (minimum 1/2-inch) on the top and capped valves (minimum 1/2-inch)

**MATERIAL SPECIFICATION
Substations and High-Voltage Equipment**

© 2007 by PacifiCorp. All rights reserved.

Engineer (M. Weisensee): *MW*
Standards Manager (G. Lyons): *GL*

**Substation Equipment—
Power Transformer, All
Ratings**



31 Oct 07

ZS 001
Page 9 of 70

ZS 001

on the bottom, to permit draining and removal of the radiators or coolers without draining oil from the transformer tank. Radiator panel steel thickness shall be a minimum of 18 gauge. The bottom of the radiator shall be no less than 18 inches above foundation level.

After all welding, the exterior surface of the radiators shall be hot-dip galvanized.

5.3 Cooling Fans

Cooling fans shall be weatherproof and corrosion-resistant, with sealed ball bearings. Fan guards shall be OSHA approved.

Fans for radiators shall be located toward the top of the radiator, or as high as is practical on the sides (not on the top) of the radiator. The coolers shall be located as low as is practical on the transformer, to provide maintenance accessibility with adequate safety clearances from transformer live parts.

Fans for radiators shall be Krenz-Vent.

5.4 Circulating Pumps

If the cooling equipment includes oil circulating pumps, an oil flow indicator with alarm contact shall be furnished for each pump to indicate low oil flow. Oil pumps shall be located near the foundation level. The supplier shall furnish suitable valves on both sides of each pump, and a pipe tap with plug (minimum 1/2 inch) at the lowest point on the pump section between the valves to permit draining, removal, and reinstallation of the pump without draining oil from the radiators or the transformer tank. If the power supply to the pumps is made through connectors which must also seal the oil system, suitable mechanical guards shall be furnished to prevent breakage of the connectors and the resultant oil leakage.

The oil circulating pumps shall be "Harley by Cardinal", with the latest Harley enhanced-bearing-system design.

5.5 Fan and Pump Control

If the cooling equipment includes two or more cooling fans, the wiring and protection for the fans shall be furnished in a minimum of two completely separate groups, so that each group will be independent of any problem or outage in the other group(s). If two stages of forced cooling are specified in Section 17.12 of this document, separate wiring and protection for each stage of fans will satisfy the requirements of this paragraph.

If the cooling equipment includes two or more oil circulating pumps, the wiring and protection for the pumps shall be furnished in a minimum of two completely separate groups, so that each group will be independent of any problem or outage in the other group(s). If two stages of forced cooling are specified in Section 17.12 of this document, and both stages include pumps, separate wiring and protection for each stage of pumps will satisfy the requirements of this paragraph.



Substation Equipment— Power Transformer, All Ratings

MATERIAL SPECIFICATION Substations and High- Voltage Equipment

© 2007 by PacifiCorp. All rights reserved.

Engineer (M. Weisensee): *MGW*
Standards Manager (G. Lyons): *GL*

ZS 001

Page 10 of 70

31 Oct 07

If the cooling equipment includes both cooling fans and oil circulating pumps, the wiring and protection for the fans shall be completely separate from the wiring and protection for the pumps, so that each system will be independent of any problem or outage in the other system.

Wiring for the cooling fans, and the oil circulating pumps if applicable, shall be arranged to allow for complete de-energization of these circuits on command from an external PacifiCorp relay in the event of a PacifiCorp transformer lockout operation.

5.6 Auxiliary Relay

For a transformer with a self-cooled rating of 5000 kVA or above (three-phase or single-phase), an auxiliary relay shall be furnished to provide an alarm indication of loss of power to the cooling equipment. This relay shall have a 30-second time delay to avoid an alarm for a momentary power loss.

5.7 Location of Control Devices

Cooling equipment control devices shall be housed in the control compartment (see Section 8.8 of this document).

6 Load Tap Changing Equipment

If specified in Section 17.14 of this document, the transformer shall be furnished with load tap changing (LTC) equipment as specified below.

6.1 Approved Load Tap Changers and Control

The supplier shall furnish the approved LTC specified in Section 17.14 of this document. For a resistance type LTC, switched in oil, the diverter (arcing) switch compartment shall be furnished with a self-contained automatic oil filter (Velcon TP-2 or approved equivalent) and a Messko MTraB-Maintenance Free Dehydrating Breather. For a reactance type LTC, switched in vacuum, a protection system with an alarm contact shall be furnished to detect a vacuum interrupter failure and prevent automatic and manual LTC operation under that condition. A Messko MTraB-Maintenance Free Dehydrating Breather shall be furnished.

An LTC series transformer may be employed when necessary and economical.

The supplier shall furnish a Beckwith type M-2270B LTC control adapter panel with Beckwith part number M-2270B-S. PacifiCorp will furnish and install a Beckwith model M-2001C LTC control.

6.2 Regulation Range

The transformer range of regulation shall be plus and minus ten percent in five-eighths (5/8) percent steps. The transformer shall be suitable for full capacity operation at the

**MATERIAL SPECIFICATION
Substations and High-Voltage Equipment**

© 2007 by PacifiCorp. All rights reserved.

Engineer (M. Weisensee): *MW*
Standards Manager (G. Lyons): *GL*

**Substation Equipment—
Power Transformer, All
Ratings**



31 Oct 07

ZS 001
Page 11 of 70

ZS 001

X-terminal nominal rated voltage and above, and reduced capacity (constant current) operation below the X-terminal nominal rated voltage. Subject to the limitations of IEEE C57.12.00 in regard to operation above rated voltage, the function of the LTC equipment shall be: (1) to maintain constant voltage at the X-terminals for fluctuating voltage applied at the H-terminals, and (2) to regulate the voltage at the X-terminals for fluctuating load level.

6.3 Listed Tap Positions

In the table of LTC tap positions on the transformer nameplate, the list of rated tap voltages shall be for the terminals of the winding in which the LTC taps are located, with one exception: if an LTC series transformer is employed, the list of rated tap voltages shall be for the terminals regulated by the series transformer.

6.4 Paralleling Equipment

The supplier shall furnish the following approved circulating-current type paralleling equipment: Beckwith model M-0115A parallel balancing module. PacifiCorp will furnish the engineering and auxiliary equipment required to coordinate with the paralleling equipment on the parallel unit.

6.5 Directional Lockout

The LTC automatic *raise* and *lower* control circuits shall be wired to a terminal block in the control compartment for connection of PacifiCorp's directional lockout equipment for parallel operation. In parallel operation, if the LTC moves abnormally out of step with the parallel transformer(s), the directional lockout equipment will prevent automatic operation in the direction that would further increase circulating current, and will include an alarm contact. The LTC manual control shall be independently wired so as to remain operative during this condition.

6.6 Provisions for Remote Control and Indication

6.6.1 Standard Provisions

If specified in Section 17.14 of this document, standard provisions for remote control and indication shall be furnished by the supplier as follows:

1. Necessary auxiliary equipment and wiring to terminal blocks in the control compartment to permit operation of the LTC by PacifiCorp's remote-manual or supervisory control equipment.
2. Incon synchro (selsyn) rotary-position transmitter with surge-suppression circuit, model 1292-KS, to provide to a local or remote Incon rotary-position monitor the electrical signals necessary for indication of LTC tap position.
3. Wiring from the contacts of the Beckwith control Auto-Off-Manual switch to a terminal block in the control compartment to permit remote indication of the position of this switch.



6.6.2 Special Additional Provisions

If specified in Section 17.14 of this document, special additional provisions for remote control and indication shall be furnished by the supplier as follows, complete with necessary wiring via terminal blocks in the control compartment:

1. Incon rotary-position monitor, programmable, model 1250B-4-120 (120 VAC, with 4-20 mA analog output), to provide, in association with the Incon transmitter specified in 6.6.1, both local display and remote indication of LTC tap position. The monitor shall be mounted on a panel in the control compartment in such a manner that the monitor will be readily visible when the compartment door is open; the monitor shall not be located behind a hinged panel or other concealment.
2. Incon surge protection module, model 1280, mounted on the Incon monitor, to protect all monitor inputs and outputs from voltage surges.
3. Incon AC-line power conditioner, model 1932, to provide a clean, stable AC voltage to power both the Incon transmitter and the Incon monitor.
4. Sola power supply, model SLS-12-017T (input range 100-240 VAC, output adjustable 12-15 VDC), for the Incon monitor output circuit.
5. Latching relay, Siemens (Potter & Brumfield), type KBP-11A-120 VAC, to permit remote selection of manual or automatic LTC control.
6. Auxiliary relay, Siemens (Potter & Brumfield), type KRP-11DG, DC, to permit remote blocking of LTC operation.

6.7 Adjustable Time Delay

An adjustable time delay shall be furnished to precede each tap change, including each of two or more consecutive tap changes.

6.8 Line Drop Compensator Current Transformers

Bushing current transformer(s) (BCT) for the line drop compensator shall be arranged as follows: if one BCT (for a power transformer X-winding specified to be wye only), the BCT shall be located on bushing X1; if two BCTs (for a power transformer X-winding specified to be delta only or delta and wye), one BCT each shall be located on bushings X1 and X3. For a transformer with both delta and wye connections available PacifiCorp will short out the X3 BCT for wye operation. The BCT(s) specified in this paragraph are in addition to the BCTs specified in Section 17.20 of this document.

The line drop compensator auxiliary current transformer (CT) shall be furnished as follows: if the power transformer X-winding is wye only, the auxiliary CT shall be rated 5 : 0.2 A; if the power transformer X-winding is delta only or delta and wye, the auxiliary CT shall be rated 5 / 8.66 : 0.2 A.

**MATERIAL SPECIFICATION
Substations and High-
Voltage Equipment**

© 2007 by PacifiCorp. All rights reserved.

Engineer (M. Weisensee):

Standards Manager (G. Lyons):

MW
GL

**Substation Equipment—
Power Transformer, All
Ratings**



31 Oct 07

ZS 001
Page 13 of 70

ZS 001

6.9 Control Voltage Transformer

PacifiCorp will furnish the necessary line-to-neutral or line-to-line control voltage transformer.

6.10 Control Voltage Electrical Isolation

The voltage circuit in the LTC control shall be electrically isolated from the control voltage transformer input furnished by PacifiCorp; the electrical isolation provided in the Beckwith model M-2001 control (see Section 6.1 of this document) satisfies this requirement.

6.11 Loss of Control Voltage

An auxiliary relay shall be furnished to prevent automatic LTC operation in the event of loss of the control voltage input to the LTC control; the auxiliary relay shall be furnished with an alarm contact. The LTC manual control shall be independently wired so as to remain operative during this condition. The auxiliary relay shall provide automatic return to normal operation upon restoration of the control voltage.

6.12 Pressure Relief Device

If the LTC is a type that is mounted on the transformer tank wall, one pressure relief device shall be furnished on the LTC oil-filled diverter-switch and tap-selector compartment. If the LTC is a type that is suspended from the transformer tank cover, one pressure relief device shall be furnished on each LTC oil-filled diverter-switch compartment.

Each LTC pressure relief device shall be Qualitrol model 208-60E, set to operate at 10 psi, and shall be mounted on top of the compartment cover. Each device shall be furnished with a Qualitrol directional shield that can be rotated 360 degrees (model SLD-603-1), a high-visibility indicator pin and alarm contact mounted on the shield, and a Qualitrol connector and cable. The mounting location of each device shall be so as to ensure visibility of the indicator pin from the ground.

Steel pipe, 4-inch ID, shall be furnished to conduct the effluent from the 4-inch opening in the shield on each device, down the side of the transformer, to a point approximately 18 inches above the transformer base. The pipe shall be securely mounted to the shield, securely supported by brackets attached to the transformer tank, and furnished with a stainless steel screen at the bottom end, using screen material similar to e.g. Qualitrol model SCN-600-1.

6.13 Rapid-Pressure-Rise Relay

If the LTC is a type that is mounted on the transformer tank wall, one rapid-pressure-rise relay shall be furnished on the LTC oil-filled diverter-switch and tap-selector compartment. The relay shall meet the applicable requirements of Section 9.5 of this document.

If the LTC is a type that is suspended from the transformer tank cover, the LTC supplier's standard rapid-pressure-rise relay shall be furnished on each LTC oil-filled diverter-switch



ZS 001

Page 14 of 70

31 Oct 07

**Substation Equipment—
Power Transformer, All
Ratings**

**MATERIAL SPECIFICATION
Substations and High-
Voltage Equipment**

© 2007 by PacifiCorp. All rights reserved.

Engineer (M. Weisensee):

Standards Manager (G. Lyons):

compartment. Each relay shall be furnished with bolted-flange mounting, one normally open and one normally closed contact, provisions for testing relay operation without removing the relay from the transformer, and a suitable connector-and-cable assembly. One seal-in relay shall be furnished in the control compartment for each rapid-pressure-rise relay.

6.14 Oil Level Indication and Protection

Oil level indication and protection for the LTC oil-filled compartment shall be furnished as specified in Section 9.3 of this document.

6.15 Top-Oil Resistance Temperature Detector

A Qualitrol resistance temperature detector (RTD), with associated thermowell, shall be furnished to detect the top-oil temperature in the LTC oil-filled compartment. The RTD shall be model 103-045, 10-ohm, copper, with Qualitrol connector and shielded cable.

6.16 Location of Control Devices

LTC equipment control devices shall be housed in the control compartment (see Section 8.8 of this document).

6.17 Tap-Winding Lead Connections

Two-bolt connections shall be used to connect the transformer LTC tap-winding leads to the LTC tap terminal board; single-bolt connections are not acceptable.

7 Bushings and Surge Arresters

7.1 Bushings

Bushings, except the core ground bushing (see Section 8.9 of this document), shall be the oil-filled capacitance-graded type with oil-impregnated core (epoxy-resin-impregnated core is not acceptable). Bushings shall be manufactured by ABB Power, Trench, HSP, Passoni-Villa, or Lapp. All non-ABB bushings shall be completely and conveniently interchangeable with ABB bushings of the same rating.

The current rating of each bushing shall be at least 10% higher than the current it will carry at the maximum forced-cooled rating. Additionally, the current rating of each neutral bushing shall not be less than the current rating of the associated line bushings.

For X-winding and Y-winding nominal voltage ratings below 13.8 kV, the BIL of the phase and neutral bushings, as applicable, shall not be less than 150 kV BIL, unless the winding terminals are directly connected to enclosed bus. Refer to Section 17.18 of this document for all BIL requirements.

The external clearances between the phase and neutral bushings of each winding (H and X, respectively), as applicable, shall meet the requirements of IEEE C57.12.00, except that the live-part clearances between bushings for a winding nominal voltage rating of 69kV or

**MATERIAL SPECIFICATION
Substations and High-
Voltage Equipment**

© 2007 by PacifiCorp. All rights reserved.

Engineer (M. Weisensee): *MW*
Standards Manager (G. Lyons): *GL*

**Substation Equipment—
Power Transformer, All
Ratings**



31 Oct 07

ZS 001
Page 15 of 70

ZS 001

below shall not be less than 30 inches. If this requirement for 69 kV or below cannot be met, the supplier shall state non-compliance to this requirement in the bid documents, and ensure that the live-part clearance is as large as possible.

7.1.1 Bushing Lead Connections

A draw-lead connection is preferred for all bushings whenever applicable. In cases where the transformer winding leads are bolted to the bottom of the bushings, two-bolt connections shall be used; single-bolt connections are not acceptable.

7.1.2 Bushing Stud Sizes and Flat-Pad Terminals

The terminal stud sizes for the bushings shall be as specified below in Table 1. The minimum length of usable threads shall be 2.25 inches.

Table 1 - Bushing Terminal Stud Sizes

Amperes	Stud Size	
	Diameter (inches)	Threads Per Inch
1200	1.5	12
1600	2.0	12
2000	2.0	12
3000	3.0	12

A straight flat-pad terminal with NEMA standard 4-hole drilling shall be furnished for each bushing. The terminals shall be bronze, copper, or aluminum, with tin plating; the minimum plating thickness shall be 0.001 inch.

7.1.3 X-Winding Neutral Ground

Provisions shall be furnished for protection of PacifiCorp's 4/0 copper conductor connecting the X0 neutral bushing terminal to the substation ground grid. The protection provision shall consist of a removable vertical length of 1-inch schedule 80 gray PVC pipe, mounted by straps bolted to supporting brackets. The pipe shall be located no more than 12 inches away from the transformer main tank side wall.

The supporting brackets shall be factory-welded to the transformer tank, or factory-welded or bolted to other suitable structural components; field welding or drilling is not acceptable.

The pipe shall be open at the top and bottom. The top of the pipe shall be approximately one foot below the X0 neutral bushing terminal, and the bottom of the pipe shall be approximately one foot above foundation level. PacifiCorp will furnish and install the copper conductor.

7.2 Surge Arresters

The transformer shall be furnished with metal-oxide, gapless-type, station-class surge arresters, as specified in Section 17.13 of this document. The arresters shall be rated for



ZS 001

Page 16 of 70

31 Oct 07

**Substation Equipment—
Power Transformer, All
Ratings**

**MATERIAL SPECIFICATION
Substations and High-
Voltage Equipment**

© 2007 by PacifiCorp. All rights reserved.

Engineer (M. Weisensee): *MGW*
Standards Manager (G. Lyons): *GL*

elevations up to 10,000 feet. The acceptable manufacturers and types of arresters are specified below in Table 2.

If the H-terminals are rated for a nominal system voltage of 525 kV (see Section 17.13 of this document), the H-terminal arresters will be furnished by PacifiCorp and installed separately.

Table 2 - Station-Class Arresters

Manufacturer	Type
ABB Power	EXLIM-Q, -P
Cooper Power Systems	VariStar ATZ
General Electric	Tranquell XE XGA or XTA
Joslyn	ZS or ZSH
Ohio Brass	Dynavar VL or VN

7.2.1 Terminals

Each surge arrester shall be furnished with a straight, vertical flat-pad line terminal with NEMA standard four-hole drilling, and with a clamp-type ground terminal connector. The terminals shall be bronze, copper, or aluminum, with tin plating; the minimum plating thickness shall be 0.001 inch.

7.2.2 Mounting Brackets

A mounting bracket for each arrester shall be furnished on the transformer adjacent to the associated bushing.

7.2.3 Discharge Counters

Discharge counters, if specified in Section 17.19 of this document, shall each be furnished with a built-in grading-leakage current indicating meter. These counters shall be manufactured by General Electric or Ohio Brass. The supplier shall also furnish necessary arrester insulating sub-bases, and provisions for mounting each counter on the transformer. Counters shall be positioned approximately five feet above foundation level for convenient inspection.

8 Other Construction Requirements

8.1 Accessory Location

Bushings, surge arresters, and load tap changing equipment, as applicable, shall be located as shown below in Figure 1. Other accessories shall be located in accordance with standards wherever applicable, or as convenient for design if not covered by standards.

**MATERIAL SPECIFICATION
Substations and High-
Voltage Equipment**

© 2007 by PacifiCorp. All rights reserved.

Engineer (M. Weisensee): *MW*
Standards Manager (G. Lyons): *GL*

**Substation Equipment—
Power Transformer, All
Ratings**



31 Oct 07

ZS 001
Page 17 of 70

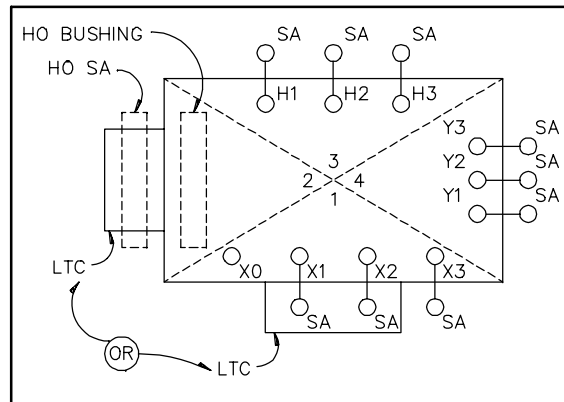

Figure 1 - Accessory Location

8.2 De-energized Tap Changer(s), Reconnection Switch(es), and Reconnection Terminal Board(s)

See Section 17.13 of this document for the specific required winding taps, winding recon-
nections, and means of reconnection.

Two-bolt connections shall be used to connect the transformer winding leads to the tap
changer(s), switch(es), and terminal board(s), as applicable; single-bolt connections are
not acceptable.

Single-bolt connections may be used only on tap changers, however double-bolt connec-
tions should be used whenever possible. Single-bolt connections require locking devices
on nuts to prevent loosening from vibration.

8.2.1 Tap Changer(s) and Reconnection Switch(es)

If de-energized voltage taps are specified in Section 17.13.1 of this document for the
H-winding, X-winding, or both windings of a single-phase transformer, a de-ener-
gized tap changer shall be furnished for each specified winding; each tap changer
shall be operated by one external handle.

If de-energized voltage taps are specified in Section 17.13.1 of this document for the
H-winding, X-winding, or both windings of a three-phase transformer, a de-ener-
gized tap changer shall be furnished for each specified winding; each tap changer
shall be three-phase or a three-phase internally-ganged assembly, operated by one ex-
ternal handle.

If de-energized series-parallel or wye-delta reconnection by means of a switch is spe-
cified in Section 17.13.2 or 17.13.3 of this document for the H-winding, X-winding,
or both windings of a three-phase transformer, a de-energized switch shall be fur-



**Substation Equipment—
Power Transformer, All
Ratings**

**MATERIAL SPECIFICATION
Substations and High-
Voltage Equipment**

© 2007 by PacifiCorp. All rights reserved.

Engineer (M. Weisensee): *MGW*
Standards Manager (G. Lyons): *GL*

nished for each specified reconnection; each switch shall be three-phase or a three-phase internally-ganged assembly, operated by one external handle.

Each tap changer or reconnection switch shall be located under oil and shall be designed to ensure positive positioning and correct external position indication. Each external operating handle, with its associated position-indication plate, shall be mounted at a height between one and five feet above foundation level and shall be furnished with provisions for padlocking in any position. An identification name-plate shall be furnished and mounted adjacent to each operating handle.

8.2.2 Reconnection Terminal Board(s)

If de-energized series-parallel or wye-delta reconnection by means of a terminal board is specified in Section 17.13.2 or 17.13.3 of this document for the H-winding, X-winding, or both windings of a three-phase transformer, a terminal board shall be furnished for each specified winding. Each terminal board shall be located under oil on top of the core-and-coil assembly and shall be arranged for convenient access through a handhole or manhole. Each terminal board shall be clearly identified, clearly marked for positive positioning of winding terminals, and designed with captive hardware.

8.3 Surge Arrester Ground Connections

The supplier shall furnish suitable electrical ground connections using bus bar between the arrester ground terminals and ground pads at the base of the transformer tank. If arrester discharge counters are specified in Section 17.19 of this document, connections between the arrester ground terminals and the discharge counter live terminals shall be insulated cable, minimum 5 kV rating; the connections from the discharge counter ground terminals to the transformer ground pads shall be bus bar.

8.4 Y-Winding Requirements

8.4.1 Special Bushings for Buried Y-Terminals

If the lowest specified rated capacity is 50 MVA or greater (see Section 17.12 of this document), and if the specified winding type is three-winding or three-winding auto-transformer (see Section 17.9 of this document) with the Y-terminals specified to be buried (see Section 17.13 of this document), the two winding terminals at one corner of the tertiary delta shall be separately brought up to two 15kV bushings mounted on the tank cover. Removable straps shall be furnished to connect the external bushing terminals together and to the tank. The bushings shall be located and labeled to avoid confusion with other bushings, and shall be protected with a removable, weather-proof metal cover.

An instruction plate shall be furnished and mounted near these bushings specifying that the external bushing terminals must be connected together and to the tank when-

ever the transformer is energized. The same instructions shall be shown on the main transformer nameplate.

8.4.2 Y-Winding Current Transformers

Current transformers inside the Y-winding delta, if specified in Section 17.20 of this document, shall be arranged as follows: (1) if three current transformers are specified, one shall be located at the polarity end of each phase winding; (2) if one current transformer is specified, the current transformer shall be located at the polarity end of any phase winding. The polarity of each current transformer shall be positioned toward the adjacent corner of the delta as shown below in Figure 2.

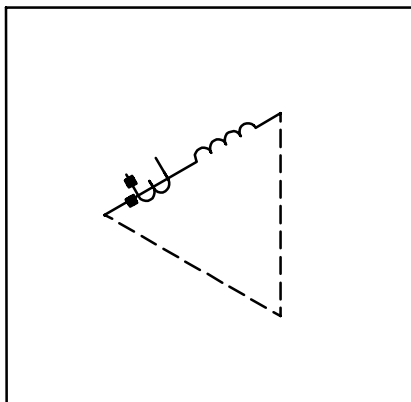

Figure 2 - Y-winding CT Arrangement

8.5 Current Transformers

8.5.1 Thermal Current Rating Factor

All current transformers, including the current transformer(s) for winding hot-spot control, shall have a continuous thermal current rating factor of 2.0.

8.5.2 Secondary Terminal Blocks

All bushing current transformer secondary leads shall be wired to six-point short-circuiting-type terminal blocks in the control compartment, as shown in Figure 3, Figure 4 and Table 14. The current transformer terminal blocks shall be laid out and each conductor marked as shown in Figure 3 and Figure 4. A separate terminal block, complete with shorting screws, shall be provided for each bushing current transformer. (See Section 17.20 of this document.)

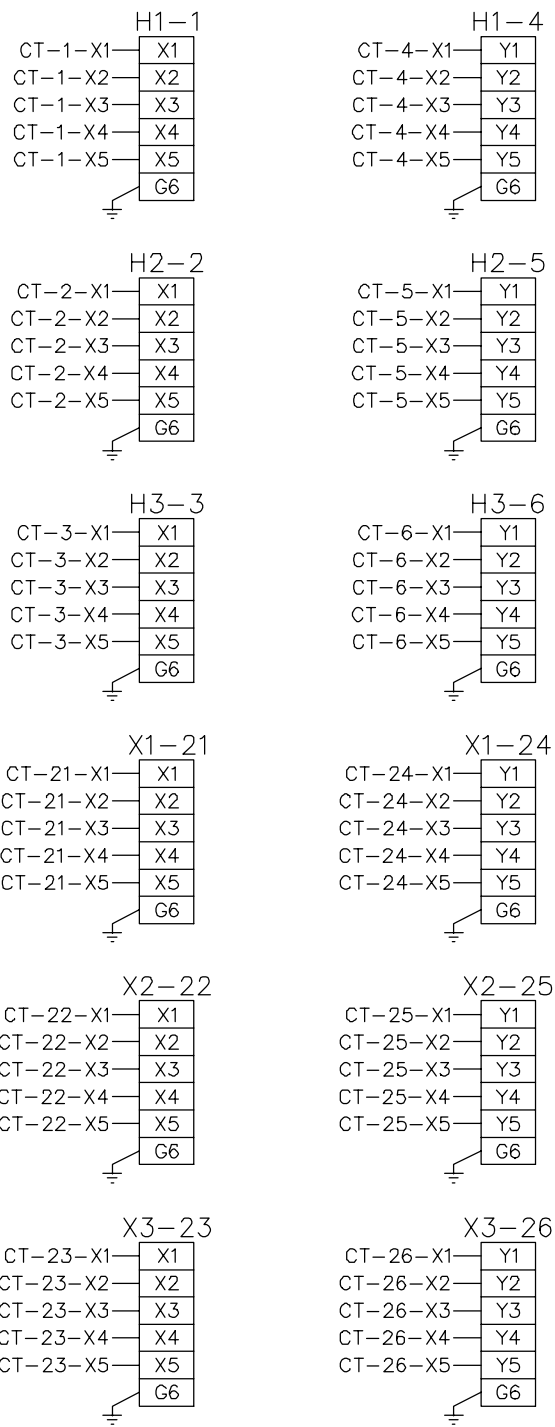

Figure 3 - Typical Connection Diagram for CT Terminal Blocks

**MATERIAL SPECIFICATION
Substations and High-
Voltage Equipment**

© 2007 by PacifiCorp. All rights reserved.

Engineer (M. Weisensee): *MW*
Standards Manager (G. Lyons): *GL*

**Substation Equipment—
Power Transformer, All
Ratings**



31 Oct 07

ZS 001
Page 21 of 70

ZS 001

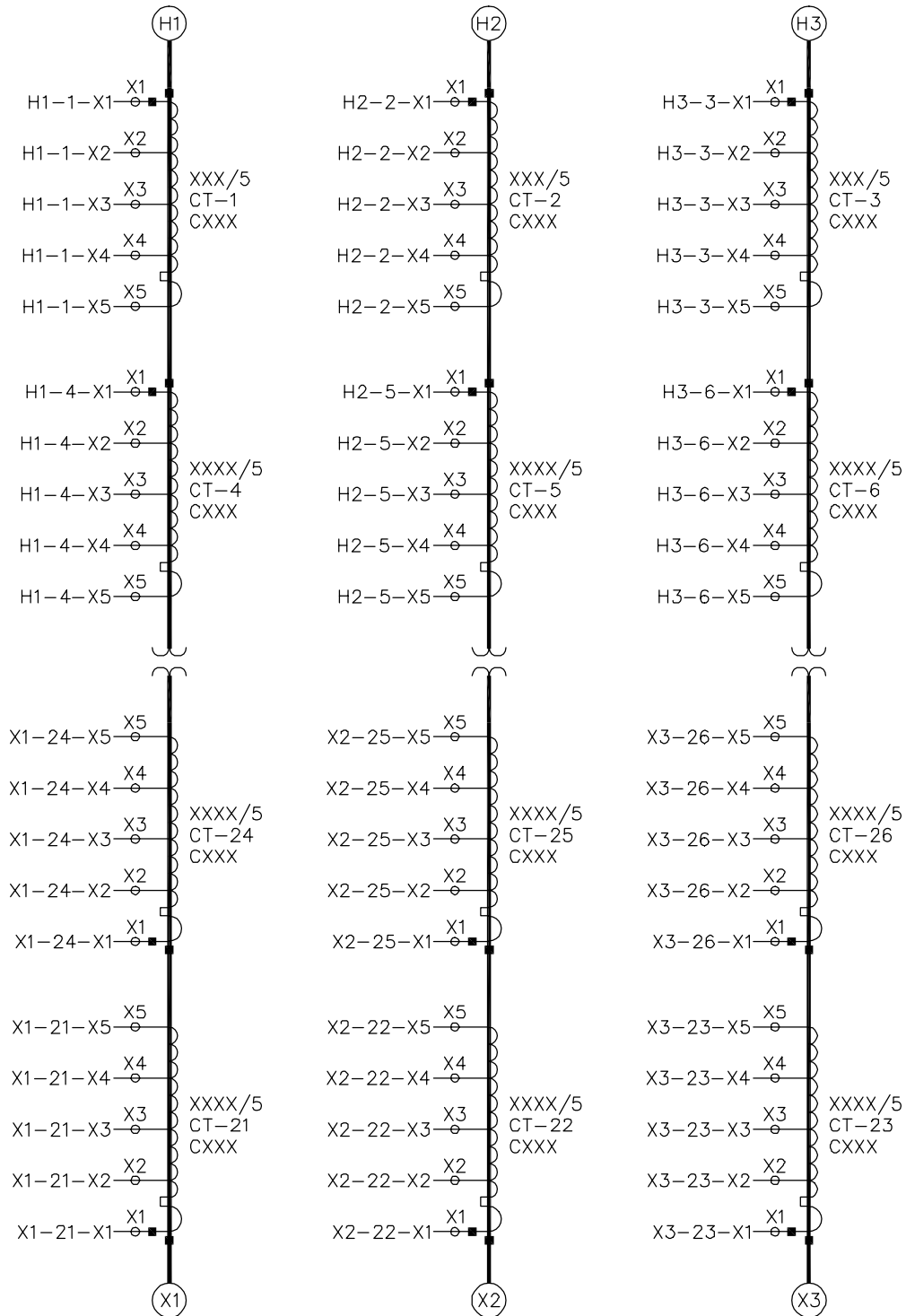

Figure 4 - Typical CT Location Diagram



Substation Equipment— Power Transformer, All Ratings

MATERIAL SPECIFICATION Substations and High- Voltage Equipment

© 2007 by PacifiCorp. All rights reserved.

Engineer (M. Weisensee): *MW*
Standards Manager (G. Lyons): *GL*

ZS 001

Page 22 of 70

31 Oct 07

8.6 Auxiliary Equipment Voltages

All output contacts for PacifiCorp use shall be rated for operation at a supply voltage up to 125 VDC. All other auxiliary equipment shall be rated for operation with the AC and DC power supplies specified in Section 17.22 of this document. PacifiCorp will furnish the AC and DC supplies.

8.7 Wiring

8.7.1 General Requirements

The auxiliary power and control wiring shall consist of stranded copper conductor, 600-volt class, with insulation (or outer covering over the insulation) that is flame-retardant, heat-resistant, oil-resistant, and moisture-resistant. Each terminal block point shall be clearly marked with the designation shown on the supplier's wiring diagrams. Each end of each conductor shall be clearly marked with two designations: the designations of the terminal block points at both the origin and the destination of the conductor.

Wiring runs outside of weatherproof enclosures shall be in rigid steel conduit, except short runs (not longer than approximately three feet), which may be in flexible, ultra-violet-resistant conduit. All conduit, fittings and connections shall be weatherproof, and all conduit connections to the enclosures shall be on the sides or bottom (not on the top) of the enclosures. For rigid conduit, all conduit and fitting connections shall be threaded; compression connections are not acceptable. Also for rigid conduit, a conduit outlet body (with angled, domed cover) shall be furnished at each 90° change of direction; 90° bends in the conduit itself are not acceptable.

The wiring materials and installation shall comply with the requirements of NFPA 70, except that the conductor fill in all conduit (calculated by area) and in all associated fittings and enclosures (calculated by volume) shall not exceed 25 percent. All exposed live parts in the control compartment or other auxiliary compartments operating above 150 V to ground shall be guarded as specified in IEEE C2.

8.7.2 Terminals and Terminal Blocks

All wires shall be terminated with uninsulated, seamless, ring-tongue compression terminals, Burndy type YAV HYLUG; except where a device has terminal mountings with nonremovable screws, the compression terminals shall be uninsulated, seamless, fork-tongue, Burndy type YAV-T-F HYLUG. Each terminal shall be the proper size for the associated wire, each terminal shall be installed on only one wire, and the terminal installation on the wire shall be accomplished using the proper Burndy HYTOOL crimping tool with a full-cycle ratchet mechanism.

All PacifiCorp-interface terminal blocks shall be one-piece molded type, rated 600 volts, 30 amperes, equipped with #10-32 washer-head binder screws with slotted

**MATERIAL SPECIFICATION
Substations and High-
Voltage Equipment**

© 2007 by PacifiCorp. All rights reserved.

Engineer (M. Weisensee): *MW*
Standards Manager (G. Lyons): *GL*

**Substation Equipment—
Power Transformer, All
Ratings**



31 Oct 07

ZS 001
Page 23 of 70

ZS 001

head, and suitable for wire sizes #18 through #10 AWG. The terminal blocks shall be GE type EB-25 or EB-27, Buchanan type 2B or 4B, or Penn Union catalog #6006 SCS shorting terminal blocks or catalog #6006 non-shorting terminal blocks. Extra terminal blocks shall be furnished and installed as spares for PacifiCorp's use; the quantity of spare terminal blocks shall be at least 10 percent of the total quantity of PacifiCorp-interface terminal blocks furnished for the necessary factory wiring.

All non-PacifiCorp-interface terminations shall also be made on suitable terminal blocks; no wires shall be spliced.

All current transformer secondary leads shall be wired to short-circuiting type terminal blocks in the control compartment. A separate six-point terminal block, complete with shorting screws, shall be furnished for each current transformer, and all current transformer secondary wiring shall be #10 AWG.

8.7.3 Fan and Pump Wiring

The wiring to each cooling fan shall consist of a Krenz-Vent power cord, with a weatherproof plug and receptacle at the fan to provide a convenient and independent means for disconnection.

The wiring to each circulating pump, as applicable, shall consist of a Harley "WeatherAll" power cord, with a weatherproof plug and receptacle at the pump to provide a convenient and independent means for disconnection.

8.8 Control Compartment

A NEMA 3R control compartment shall be furnished to house cooling equipment control devices, LTC equipment control devices if applicable, and terminal blocks for terminating all auxiliary wiring. PacifiCorp will bring all external auxiliary power and control wiring in conduit to the control compartment; the compartment shall be furnished with a removable bottom plate for drilling by PacifiCorp. The compartment door shall be vertically hinged, removable, and operated by a single handle.

The controls, terminal blocks, and other devices requiring access for operation and maintenance shall be mounted in the compartment at a height less than 6 feet above foundation level. The bottom of the compartment shall be not less than 2 feet above foundation level.

The compartment shall be furnished with two 240 VAC space heaters. One heater shall be connected to operate continuously. The second heater shall be controlled by a thermostat; the thermostat shall be adjustable, and the adjustment provisions shall include clear indication of a least three specific temperatures on the adjustment range.

The compartment shall be furnished with one 120 VAC, 20 A, industrial grade, duplex convenience receptacle.



ZS 001

Page 24 of 70

31 Oct 07

**Substation Equipment—
Power Transformer, All
Ratings**

**MATERIAL SPECIFICATION
Substations and High-
Voltage Equipment**

© 2007 by PacifiCorp. All rights reserved.

Engineer (M. Weisensee):

Standards Manager (G. Lyons):

The PacifiCorp equipment number (see Section 17.1.1 of this document) shall be stenciled on the control compartment door.

8.9 Core Ground

The core ground shall be internal or external, as specified in Section 17.26 of this document.

For each core, a separate insulated cable shall be furnished for grounding. These cables shall be brought up to a location near the top of the tank and there connected together; this connection shall be removable, and shall be designed with captive hardware. The connection location shall be easily accessible from a manhole or handhole on the transformer cover, and the location shall be clearly identified on the transformer nameplate and marked on the appropriate manhole or handhole cover.

For an internal core ground, the cables shall be grounded to the tank from the connection location described above.

For an external core ground, a single insulated cable shall be brought from the connection location described above to a single core ground bushing mounted on the tank cover or near the top of the tank wall, with a removable strap between the external bushing terminal and the tank. The bushing shall be located and labeled to avoid confusion with other bushings, and shall be protected with a removable, weatherproof metal cover. The transformer shall be shipped with this bushing installed.

An instruction plate shall be furnished and mounted near the core ground bushing specifying that the external bushing terminal must be connected to the tank whenever the transformer is energized. The same instructions shall be shown on the main transformer nameplate.

8.10 Insulating Oil

The supplier shall furnish the necessary quantity of insulating oil (independently of the party responsible for shipping or installing the transformer). The oil shall meet the requirements of PacifiCorp Material Specification ZS 061.

8.11 Oil Preservation System

As specified in Section 17.27 of this document, one of the following oil preservation systems shall be furnished. The design and mounting arrangement of the associated pressure-vacuum gauge shall permit reading the dial from the ground. The transformer shall be shipped with the pressure-vacuum gauge installed.

8.11.1 Sealed Tank

A sealed-tank system shall be complete with a pressure-vacuum gauge and bleeder device, Qualitrol model 070-35C (including gauge model 050-35E, with a dial

range of -10 to +10 psig; and bleeder model 351-2A, with an adjustment range of 3-12 psig for both pressure and vacuum).

8.11.2 Nitrogen-Gas Pressure

A nitrogen-gas pressure system shall include a nitrogen cylinder installed in a cabinet mounted on the transformer tank, with a three-stage pressure regulating system, a pressure-vacuum gauge, pressure relief valves, and alarm contacts to indicate high and low nitrogen pressure in the transformer tank and low nitrogen pressure in the cylinder.

The cylinder shall be secured in the cabinet by a chain. The cabinet shall be furnished with a vertically-hinged door operated by a single handle. To facilitate replacement of the cylinder, the inside surface of the floor of the cabinet shall be not less than 2 inches and not more than 4 inches above foundation level. Also, across the front edge of the floor there shall be no weather strip or other obstruction above the surface of the floor; the bottom edge of the cabinet door need not be sealed.

The cylinder shall be furnished with the U.S. standard outlet connection for nitrogen gas, designated by the Compressed Gas Association as CGA 580. The thread specification is 0.965"-14 NGO-RH-INT (0.965-inch diameter, 14 threads per inch, National Gas Outlet form, right-hand internal thread).

8.11.3 Conservator

8.11.3.1 Conservator System

A conservator system shall include a conservator tank with a nitrile or urethane bladder. The air space inside the bladder shall be vented to outside air through a desiccant (Messko MTraB-Maintenance Free Dehydrating Breather). One conservator tank is preferred, located at either end of the transformer (segment 2 or segment 4). As an alternate arrangement, if necessary or advantageous for the transformer design, the supplier may furnish two conservator tanks, one located at each end of the transformer (segment 2 and segment 4). A conservator tank located directly above the transformer is not acceptable.

The conservator tank(s) and supporting structure(s) shall not conflict with mounting and proper use of PacifiCorp's fall arrest equipment (see Section 8.18 of this document) and safety railing equipment (see Section NO TAG of this document), or with convenient, workable access to the necessary manholes and handholes (see Section 8.12 of this document).

For each conservator tank, the bladder shall be designed for flange installation (clamps are not acceptable), and shall be sealed to prevent contact between the oil in the conservator tank and the air. In terms of total oil temperature, each conservator tank shall be of sufficient volume to operate through an oil temper-



**Substation Equipment—
Power Transformer, All
Ratings**

**MATERIAL SPECIFICATION
Substations and High-
Voltage Equipment**

© 2007 by PacifiCorp. All rights reserved.

Engineer (M. Weisensee): *MGW*
Standards Manager (G. Lyons): *GL*

ature range of -50° C (without causing the low-oil-level alarm contacts to close) to +115° C (without exceeding the recommended maximum oil level). The bottom of each conservator tank shall be higher than the top of the highest bushing adapter turret. Each conservator tank shall be designed for full-vacuum filling with pressures equalized inside and outside the bladder.

For each conservator tank, the opening to the oil line at the bottom of the tank shall be shielded to prevent being closed off by the bladder in the event of a drop in the oil level below that point.

For each conservator tank, the desiccant container in the air-space vent line shall be located so it can be safely maintained from ground level with the transformer energized.

A temporary pressure-vacuum gauge shall be furnished for monitoring the pressure in the main transformer tank during shipment. The gauge shall be Qualitrol model 050-35E, with a dial range of -10 to +10 psig.

Refer to Section 8.14 of this document for specific requirements related to the field processing and filling procedure.

8.11.3.2 Gas Collection Design

The transformer shall be designed to provide for gas collection adequate for transformer protection purposes. Specifically, the transformer shall be furnished in accordance with the requirements described below and in Section 12.6 of this document.

The transformer cover shall have a minimum upward slope of three degrees from the outer edges of segments 1 and 3 of the cover toward the center of the cover. Gas collecting ports shall be furnished on the central ridge of the cover at intervals not exceeding 30 inches. In addition, all manholes and bushing turrets shall have collecting ports. All collecting ports shall be connected to the gas detector chamber (see Section 9.6 of this document) with piping having a minimum upward slope of three degrees. All gas piping, fasteners, and hardware shall be stainless steel with compression fittings (see Section 8.17 of this document).

8.12 Tank Design

The transformer tank shall be designed for full-vacuum filling. The main tank cover and all tank joint flanges shall be welded.

Except for welding associated with a shipping cover (see Section 16.5 of this document), any requirement for field welding on a tank surface adjacent to the tank interior is not acceptable.

**MATERIAL SPECIFICATION
Substations and High-Voltage Equipment**

© 2007 by PacifiCorp. All rights reserved.

Engineer (M. Weisensee): *MW*
Standards Manager (G. Lyons): *GL*

**Substation Equipment—
Power Transformer, All
Ratings**



31 Oct 07

ZS 001
Page 27 of 70

ZS 001

Manholes and handholes shall be furnished and located to provide convenient, workable access to the interior of the tank for all necessary installation and maintenance procedures, including items such as terminal board connections, internal bushing terminal connections, removal and replacement of bushing current transformers, and full personnel access for internal inspection. Each manhole and handhole shall be furnished with a gasketed, bolted cover, with lifting eyes if necessary to conveniently handle the weight.

Manholes, handholes, and all other openings in the tank cover employing gaskets shall be raised above the cover surface to prevent moisture accumulation around the gasketed joints.

The transformer centers of gravity, horizontal and vertical, both as prepared for shipment and as completely assembled for service, shall be clearly identified and marked on appropriate instruction plates mounted on the segment 1 or 3 side and on the segment 2 or 4 end of the tank wall.

Facilities for lifting and moving the complete transformer shall be suitable for handling the transformer filled with oil. The jacking pads shall be approximately, and not less than, 2 feet above foundation level.

8.13 Valve Requirements

All valves shall be full port. All valves shall be ball-type except the combination drain and lower filter valve described below, and the radiator valves if applicable. All valves open on one or both sides to the interior of the transformer tank or other oil-containing components, shall be flange-mounted, with gasket, on the side(s) open to the interior; threaded fittings are not acceptable.

The upper filter valve shall be located on the tank side wall in segment 1 in accordance with ANSI C57.12.10, and the valve size shall be two-inch. If a conservator oil preservation system is specified by PacifiCorp or selected by the supplier in accordance with Section 17.27 of this document, a four-inch valve for vacuum connection shall be furnished on the tank cover in segment 3.

The combination drain and lower filter valve shall be globe-type, two-inch. A 90-degree elbow assembly shall be furnished on the interior side of the valve, oriented downward with the bottom face (opening) of the elbow assembly parallel to the bottom of the tank to allow pumping the oil out of the transformer to within 3/8-1/2" from the bottom.

8.14 Valves and Field Oil-Filling Procedure for Transformer with Conservator System

If a conservator oil preservation system is specified by PacifiCorp or selected by the supplier in accordance with Section 17.27 of this document, the transformer will be field processed and filled with oil in accordance with the procedure specified in this section. The supplier shall furnish the specified valves and design the transformer for convenient application of the specified procedure.



ZS 001

Page 28 of 70

31 Oct 07

**Substation Equipment—
Power Transformer, All
Ratings**

**MATERIAL SPECIFICATION
Substations and High-
Voltage Equipment**

© 2007 by PacifiCorp. All rights reserved.

Engineer (M. Weisensee): *MGW*
Standards Manager (G. Lyons): *GL*

The list below describes the procedure. See Figure 5 below for the valve locations and Table 3 below for the initial valve positions.

1. Verify that all devices that cannot withstand full vacuum are isolated, including the Hydran monitor and the rapid-pressure-rise relay(s).
2. Remove the de-hydrating breather and install a nitrogen cylinder or dry air cylinder.
3. Start the vacuum pump.
4. After the required vacuum has been reached, introduce oil through valve 7.
5. Fill with oil to approximately 12 inches below the main cover.
6. Close valve 1 and shut down the vacuum pump.
7. Continue to feed oil until the oil level is approximately at the 25° C level. Use the sight tube to determine the oil level since the oil level gauge may read incorrectly due to the collapsed bladder.
8. Close valve 7.
9. Close valves 5, 6 and 8. Remove the sight tube.
10. Slowly open valve 4 until the bladder is pressurized to 1.5 psig. Close valve 4.
11. Open valve 7 and feed additional oil until air is bled off at valve 6 and at the conservator vent plug opening. Close valve 6 and replace the conservator vent plug.
12. Adjust the oil to the correct level based on temperature. Use the oil level gauge to determine the level. Close valve 7.
13. Disconnect the nitrogen cylinder or dry air cylinder.
14. Slowly open valve 4 to release the pressure on the bladder.
15. Reconnect the de-hydrating breather to valve 4.
16. Bleed all cover items that do not have piping to the gas detector relay.
17. Verify that all valves are returned to the initial positions, and that all devices isolated in step 1 above are returned to normal operation.

**MATERIAL SPECIFICATION
Substations and High-
Voltage Equipment**

© 2007 by PacifiCorp. All rights reserved.

Engineer (M. Weisensee):

Standards Manager (G. Lyons):

MW
GL

**Substation Equipment—
Power Transformer, All
Ratings**



31 Oct 07

ZS 001

Page 29 of 70

ZS 001

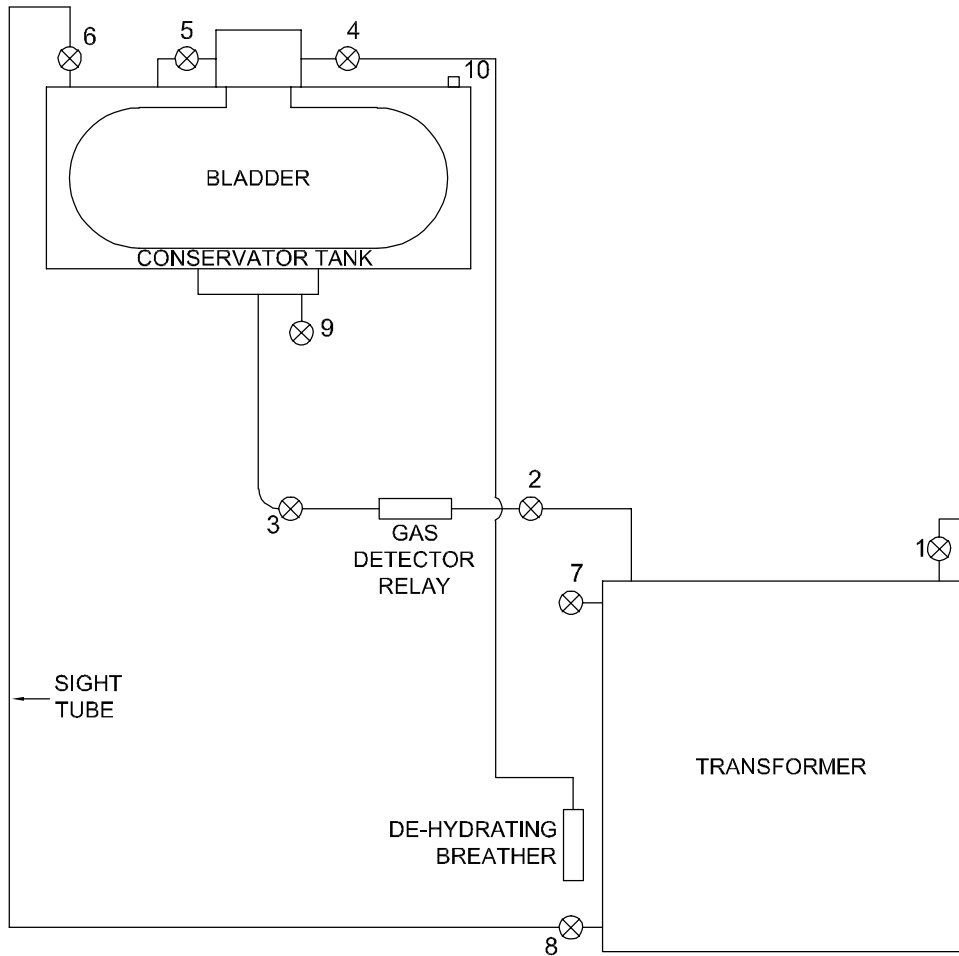

Figure 5 - Valve Location Schematic Drawing



**Substation Equipment—
Power Transformer, All
Ratings**

**MATERIAL SPECIFICATION
Substations and High-
Voltage Equipment**

© 2007 by PacifiCorp. All rights reserved.

Engineer (M. Weisensee): *MW*
Standards Manager (G. Lyons): *GL*

ZS 001

Page 30 of 70

31 Oct 07

Table 3 - Initial Valve Positions

Valve No.	Position	Function
1	Open	<i>Permanent</i> valve for vacuum connection
2	Open	Connecting valve between conservator and main tank
3	Open	Connecting valve between conservator and main tank
4	Closed	Connects to de-hydrating breather
5	Open	Equalizing valve between bladder and conservator
6	Open	Connects to temporary sight tube
7	Open	Upper filter valve; connects to oil supply hose
8	Open	Drain and lower filter valve; connects to temporary sight tube
9	Closed	Conservator drain valve
10	Closed	Conservator vent plug

8.15 Gaskets and Internal Washers

All gasketed surfaces shall be designed with gasket grooves. Gasket stops are not acceptable. Internal split-lock washers are not acceptable.

8.16 Welds

For all components and accessories attached by welding, the welds shall be continuous; spot welds are not acceptable.

8.17 Exposed Fasteners and Hardware

With the exception of nuts, all exposed fasteners and hardware (such as bolts, screws, washers, hinges, handles, brackets, and ground pads) shall be 300-series stainless steel, if not welded. If welded, 304L stainless steel shall be used. All nuts shall be silicon-bronze to prevent galling. If supplier prefers, the ground pads may instead be copper-faced steel as permitted by ANSI C57.12.10.

8.18 Fall Arrest Equipment Base Plate

The supplier shall furnish a Pelsue weld-on base plate, part #PNUH4000-2, on the top of the transformer cover for each manhole cover. The plate shall be permanently welded in a location not more than 12 inches from each manhole cover, and shall comply with all requirements for fall arrest and confined space rescue as determined by Pelsue, the manufacturer of PacifiCorp's OSHA-certified fall arrest equipment.

8.19 Ladder

If specified in Section 17.31 of this document, the supplier shall furnish a ladder for access to the top of the transformer main tank. The equipment shall comply with OSHA requirements.

The ladder shall be mounted on the main tank side wall at a location that will not interfere with any transformer component or hardware, and that will provide sufficient free space for

ZS 001

convenient access at both the bottom and top of the ladder. The ladder shall be removable, mounted by bolting to permanent supporting brackets welded to the tank. The top of the ladder side rails shall be level with the top of the tank cover, the top ladder rung shall be approximately 12 inches below the top of the tank cover, and the centerline of the ladder rungs shall be approximately and not less than 10 inches away from the tank and tank bracing members. The ladder will normally remain in place when the transformer is energized, and therefore shall be taken into account in the design of electrical clearances; the ladder is intended to be temporarily removed only when necessary, such as for any modifications.

At the bottom end of the ladder, a security door shall be furnished to prevent unauthorized access to the ladder; the door shall extend from below the bottom ladder rung up to a height approximately 7 feet above the base of the transformer, and shall be furnished with provisions for padlocking. A safety cage shall be mounted on the ladder, extending from approximately 8 feet above the base of the transformer up to the top of the ladder side rails.

The ladder shall be Type 1A with a weight rating of 350 pounds; the side rails and rungs shall be tubular; and the ladder width between side rail centerlines shall be approximately and not less than 24 inches. The safety cage shall provide inside personnel clearance of not less than 27 inches side-to-side and front-to-back.

8.20 Safety Railing Equipment

If specified in Section 17.32 of this document, the supplier shall supply safety railing equipment designed to provide perimeter fall protection for personnel on the tank cover, and to prevent tools from falling off the cover. The equipment shall comply with OSHA requirements.

The safety railing equipment shall consist of posts located around the perimeter of the top of the main tank, three separated courses of rope barrier supported by eyes on the posts, and a kickboard located along the perimeter of the main tank cover (see Figure 6 and Figure 7).

The railing posts shall be arranged for temporary installation on permanent supporting studs near the top of the tank side walls. The posts will be removed before energizing the transformer. One post shall be located adjacent to each side of the ladder. The spacing between all other posts shall be as convenient for the transformer design, but not more than approximately 48 inches. Each post shall be round aluminum pipe, 1.5-inch ID, 52 inches long, with three vertical eyes (1-inch ID) welded in line on the side of the post facing the transformer to support the rope; the eyes shall be located at 20, 35, and 50 inches from the bottom of the post. Two inches from the bottom of each post, the post shall be drilled in the direction parallel to the tank side wall, and a pin shall be furnished for securing the post to the supporting stud; to avoid loss, the pin shall be attached to the post by a short length of small chain. All welds shall be ground smooth, and the edges on both ends of each post shall be ground and reamed smooth for safety.



Substation Equipment— Power Transformer, All Ratings

MATERIAL SPECIFICATION Substations and High- Voltage Equipment

© 2007 by PacifiCorp. All rights reserved.

Engineer (M. Weisensee): *MGW*
Standards Manager (G. Lyons): *GL*

ZS 001

Page 32 of 70

31 Oct 07

The supporting stud furnished for each post shall be welded to a standoff bracket welded to the tank side wall, with the top of the stud level with the top of the tank cover. Each stud shall be 1.4375-inch OD, 4 inches long, and drilled in the direction parallel to the tank side wall for the post securing pin. Each stud shall be located so as not to interfere with any transformer component or hardware, and so that there will be a gap between the installed post and the edge of the tank cover of approximately 0.5 inch.

The kickboard shall be furnished in removable sections along the entire perimeter of the tank cover, except that no kickboard shall be furnished in the area between the posts at the ladder location. The kickboard shall be mounted by bolting to permanent supporting brackets welded in place near the edge of the cover. The kickboard will remain in place when the transformer is energized, and therefore shall be taken into account in the design of electrical clearances; the kickboard is intended to be temporarily removed only when necessary, such as for any modifications. The kickboard shall consist of vertical 0.25 x 3 inch steel bar. The spacing between the mounting brackets shall be as convenient for the transformer design, but not more than approximately 24 inches. The bracket design shall be such that the bottom edge of the kickboard will be supported approximately 0.5 inch above the surface of the main tank cover to allow for drainage.

The rope shall be U.S. Rope & Cable, 0.5-inch diameter, 3-strand, polypropylene-polyester combination, and white color with red marker. Each of the three rope courses will be tied off at the posts adjacent to each side of the ladder. Each rope will be tied off so that it is taut, with a maximum deflection (including the free hanging sag in the rope) of 3 inches in any direction when a load of 200 pounds is applied in any direction at any point on the rope.

An aluminum cabinet shall be furnished and mounted on the transformer to store the removable equipment.

**MATERIAL SPECIFICATION
Substations and High-
Voltage Equipment**

© 2007 by PacifiCorp. All rights reserved.

Engineer (M. Weisensee):

Standards Manager (G. Lyons):

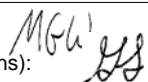

**Substation Equipment—
Power Transformer, All
Ratings**



31 Oct 07

ZS 001
Page 33 of 70

ZS 001

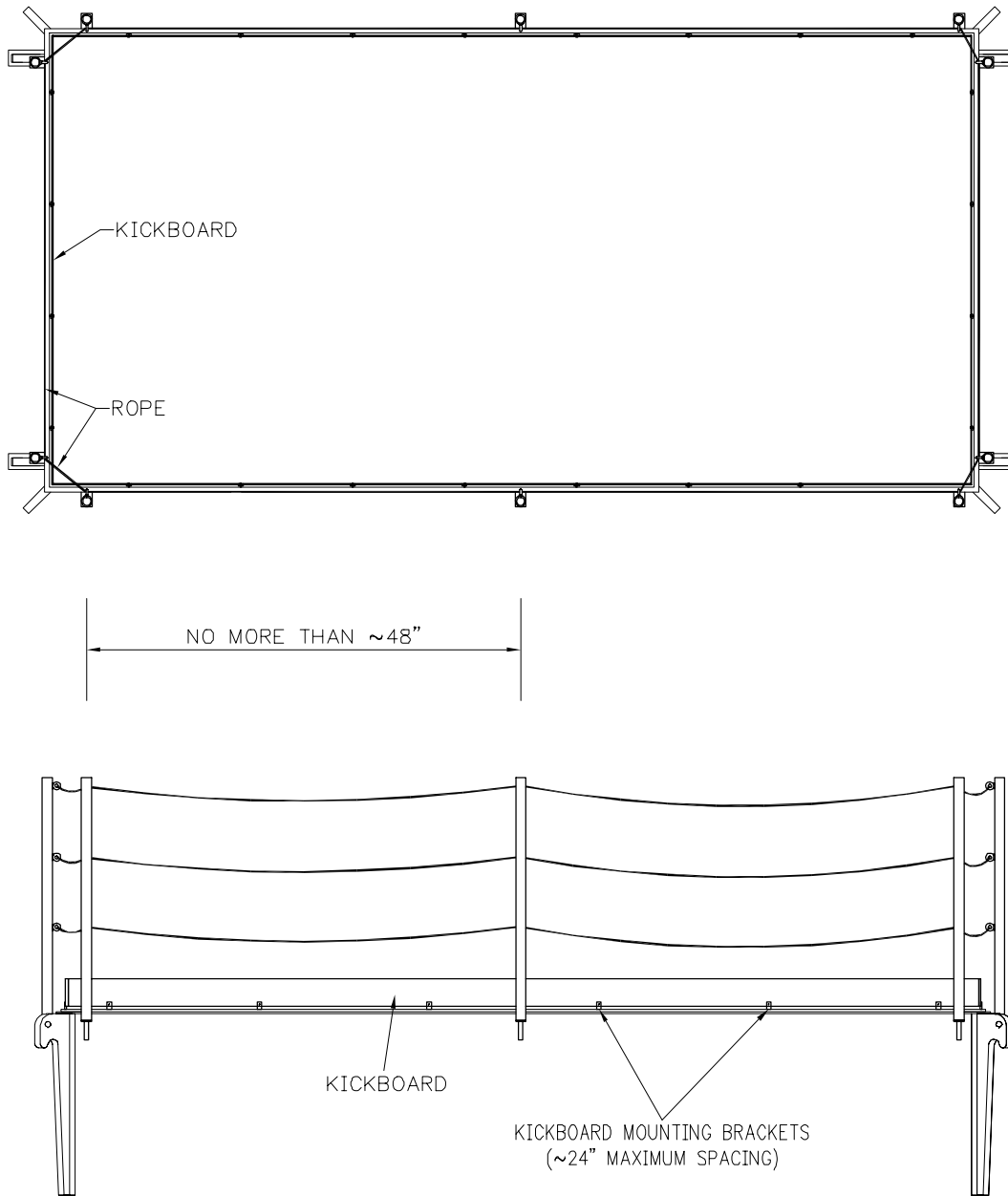

Figure 6 - Safety Railing System Overview



**Substation Equipment—
Power Transformer, All
Ratings**

**MATERIAL SPECIFICATION
Substations and High-
Voltage Equipment**

© 2007 by PacifiCorp. All rights reserved.

Engineer (M. Weisensee): *MW*
Standards Manager (G. Lyons): *GL*

ZS 001
Page 34 of 70

31 Oct 07

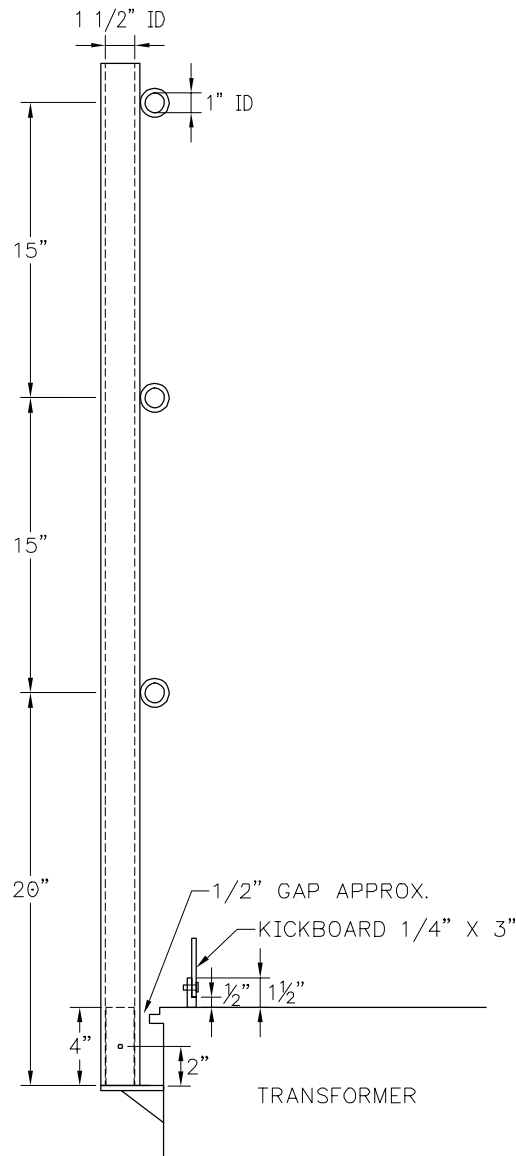

Figure 7 - Safety Railing Post and Kickboard Detail

**MATERIAL SPECIFICATION
Substations and High-
Voltage Equipment**

© 2007 by PacifiCorp. All rights reserved.

Engineer (M. Weisensee):

Standards Manager (G. Lyons):

MW
GL

**Substation Equipment—
Power Transformer, All
Ratings**



31 Oct 07

ZS 001

Page 35 of 70

ZS 001

9 Other Auxiliary Protection Device Requirements

9.1 Auxiliary Device Contacts

All auxiliary device contacts shall be normally open and ungrounded. Both sides of each contact shall be isolated from all other contacts and independently wired to terminal blocks in the control compartment. All contacts specified to be used to trip PacifiCorp's switching device shall be non-failsafe.

9.2 Indicating Lights

All indicating lights shall be long-life, high-visibility LEDs.

9.3 Oil Level Indication and Protection

9.3.1 Oil Level Indicator(s)

A Qualitrol dial-type oil level indicator shall be furnished on the main transformer tank, or on each conservator tank if applicable, and on the LTC oil-filled compartment if LTC is specified in Section 17.14 of this document. Each indicator on a conservator tank shall be shielded to prevent the bladder from interfering with the operation of the indicator.

Each indicator shall be similar to series 032, 6-inch, lever drive, with one contact unless two contacts are specified in Section 17.23 of this document, and with a Qualitrol connector and cable. The indicator mounting arrangement shall permit reading the dial from the ground.

For all transformers, one contact shall be set to close at the minimum safe operating level, and will be used to activate PacifiCorp's alarm. If two contacts are specified, the second contact shall be set to close at a level below the minimum safe operating level but above the level that would result in transformer failure, and may be used to trip PacifiCorp's switching device.

9.3.2 Backup Oil Level Detector(s)

If specified in Section 17.23 of this document, a Qualitrol backup oil level detector, nonindicating, shall be furnished on the main transformer tank, or on each conservator tank if applicable, and on the LTC oil-filled compartment if LTC is specified in Section 17.14 of this document. Each detector on a conservator tank shall be shielded to prevent the bladder from interfering with the operation of the detector.

Each detector shall be identical to the indicator(s) specified in Section 9.3.1 of this document, except always with two contacts, and with the dial lens painted to prevent viewing the dial. Each detector shall be clearly labeled "NONINDICATING" by means of a nameplate attached to the tank adjacent to the detector.



One contact shall be set to close at the same level as the alarm contact on the respective oil level indicator specified in Section 9.3.1 of this document (the contact shall be wired in parallel with the alarm contact on the respective oil level indicator so that closing of either contact will activate the alarm). The second contact shall be set to close at the same level as the trip contact on the respective oil level indicator specified in Section 9.3.1 of this document (the contact shall be wired in series with the trip contact on the respective oil level indicator so that both contacts must be closed to initiate a trip operation).

9.4 Main Tank Pressure Relief Device(s)

Qualitrol self-resealing mechanical pressure relief device(s) shall be furnished on the main transformer tank, as specified below. Each device shall be model XPRD00-00021642, set to operate at 12 psi. Each device shall be furnished with an integral directional shield that can be rotated 360 degrees, a high-visibility indicator pin and alarm contact mounted on the shield, and a Qualitrol connector and cable. The mounting location of each device shall be so as to ensure visibility of the indicator pin from the ground.

If the H-terminals are rated for a nominal system voltage of 345 kV or above, three pressure relief devices shall be furnished. If the H-terminals are rated for a nominal system voltage below 345 kV, one pressure relief device shall be furnished for each 10,000 gallons (or fraction thereof) of insulating oil in the main tank and oil preservation and cooling systems.

The pressure relief device shall be mounted on the top of the transformer near the tip of the side wall of the main tank. The electrical connector and the 8-inch opening in the shield on each device shall be pointed directly down. If more than one device is furnished as specified above, the devices shall be installed at widely separated locations along the perimeter of the tank wall, and the alarm contacts shall be wired in parallel so that closing of any contact will activate the alarm.

A steel pipe, 10-inch ID, shall be furnished to conduct the effluent from the 10-inch opening in the shield on each device, down the side of the transformer, to a point approximately 18 inches above the transformer base. The pipe shall be securely mounted to the shield, securely supported by brackets attached to the transformer tank, and furnished with a Qualitrol stainless steel flap at the bottom end.

If load tap changing equipment is specified in Section 17.14 of this document, see the pressure relief device requirements in Section 6.12 of this document.

9.5 Main Tank Rapid-Pressure-Rise Relay

One oil-space, rapid-pressure-rise relay or provisions for such relay, as specified in Section 17.24 of this document, shall be furnished on the transformer tank, located near the control compartment and approximately seven feet above foundation level.

The rapid-pressure-rise relay shall be Qualitrol model 900-009-03, vented, with bolted-flange mounting, one normally open and one normally closed contact, provisions for test-

**MATERIAL SPECIFICATION
Substations and High-Voltage Equipment**

© 2007 by PacifiCorp. All rights reserved.

Engineer (M. Weisensee): *MW*
Standards Manager (G. Lyons): *GL*

**Substation Equipment—
Power Transformer, All
Ratings**



31 Oct 07

ZS 001
Page 37 of 70

ZS 001

ing relay operation without removing the relay from the transformer, and a Qualitrol series CON-603 connector-and-cable assembly. One seal-in relay shall be furnished in the control compartment for the rapid-pressure-rise relay, Qualitrol model 909-210-01.

A suitable two-inch ball valve shall be furnished for mounting the rapid-pressure-rise relay, to permit removing the relay without draining oil from the transformer tank. The valve shall have provisions for padlocking in both the fully opened and fully closed positions.

Provisions for future installation of the rapid-pressure-rise relay shall include the following furnished on the transformer: the ball valve, the terminal blocks necessary to complete all future wiring, and provisions for future installation of the seal-in relay.

If load tap changing equipment is specified in Section 17.14 of this document, see the rapid-pressure-rise relay requirements in Section 6.13 of this document.

9.6 Gas Detector Relay

If a conservator oil preservation system is specified by PacifiCorp or selected by the supplier in accordance with Section 17.27 of this document, one gas detector relay, ABB model 11, shall be furnished.

9.7 Alarm Monitor

If specified in Section 17.25 of this document, a Rochester Instrument Systems 12-point alarm monitor shall be furnished. The monitor shall include the following for each point:

1. One input contact
2. An individual indicating long-life, high-visibility LED
3. Individual points labeled as specified below
4. One retransmitting auxiliary contact

The monitor shall be mounted in the control compartment in such a manner that the monitor will be readily visible when the compartment door is open; the monitor shall not be located behind a hinged panel or other concealment. The supplier shall furnish individual wiring of alarm circuits from dedicated alarm terminal blocks in the control compartment to the monitor, and individual wiring from the monitor retransmitting auxiliary contacts to a separate terminal block in the control compartment for PacifiCorp's use.

Applicable alarms shall be arranged on the monitor in the order listed below, and each point shall be labeled with the identification wording shown. In some cases more than one alarm is specified on a single point with the intent that any one of the specified alarms will activate that point (note that if LTC is not applicable, the words "OR LTC" shall be deleted from the nameplate for the point shown below as #8). All unused points shall be grouped together at the bottom of the monitor and shall serve as spares (with blank nameplates) or may be used by the supplier for other necessary alarms.

1. GAS DETECTOR RELAY
GAS ACCUMULATION



ZS 001

Page 38 of 70

31 Oct 07

**Substation Equipment—
Power Transformer, All
Ratings**

**MATERIAL SPECIFICATION
Substations and High-
Voltage Equipment**

© 2007 by PacifiCorp. All rights reserved.

Engineer (M. Weisensee): *MGW*
Standards Manager (G. Lyons): *GL*

- 2. COOLING EQUIPMENT
POWER LOSS
- 3. MAIN TANK OIL
LOW LEVEL
- 4. FORCED OIL
LOW FLOW
- 5. MAIN TANK OIL
HIGH TEMP
- 6. MAIN TANK / LTC OIL
DIFFERENTIAL TEMP
- 7. WINDING HOT-SPOT
HIGH TEMP
- 8. PRESSURE RELIEF
MAIN TANK OR LTC
- 9. NITROGEN PRESSURE
MAIN TANK HIGH OR LOW
OR CYLINDER LOW
- 10. LTC OIL
LOW LEVEL
- 11. LTC VACUUM BOTTLE
FAILURE
- 12. LTC
DIRECTIONAL LOCKOUT OR
CONTROL VOLTAGE LOSS

10 Nameplate Requirements

10.1 General

All wording on transformer and accessory identification labels, nameplates, and instruction plates shall be in English only; all numerical values shall be in U.S. customary units only.

10.2 Main Transformer Nameplate

The main transformer nameplate, titled “Power Transformer”, shall be furnished and mounted externally on or near the control compartment in a location to permit reading from the ground. Information shown on the nameplate shall include the following items in addition to or in clarification of those specified in IEEE C57.12.00.

- 1. PacifiCorp equipment number

**MATERIAL SPECIFICATION
Substations and High-
Voltage Equipment**

© 2007 by PacifiCorp. All rights reserved.

Engineer (M. Weisensee): *MW*
Standards Manager (G. Lyons): *GL*

**Substation Equipment—
Power Transformer, All
Ratings**



31 Oct 07

ZS 001
Page 39 of 70

ZS 001

2. rated elevation
3. rated daily minimum and daily peak ambient temperatures
4. Y-winding voltage and capacity ratings, if applicable, whether the terminals are specified to be brought out or buried
5. transformer winding and current transformer polarity marks
6. applicable instructions concerning the special bushings for a buried Y-winding (see Section 8.4.1 of this document) and concerning the core ground bushing (see Section 8.9 of this document)
7. weight of the transformer prepared for shipment
8. listing of the separate volumes and weights of oil in the main transformer tank, the radiators, the conservator tank(s) if applicable, and the LTC oil-filled compartment if applicable.

10.3 Load Tap Changer Nameplate

A separate LTC nameplate, titled “Load Tap Changer”, shall be furnished and mounted externally near the main transformer nameplate in a location to permit reading from the ground. The nameplate shall include the LTC manufacturer, model number, serial number, and instruction book number. The nameplate shall also state the capability of the LTC oil-filled compartment in regard to withstanding full vacuum.

10.4 Valve Identification and Location Nameplate

A separate nameplate showing the valve locations, titled “Valve Identification and Location”, shall be furnished and mounted externally near the main transformer nameplate in a location to permit reading from the ground. The nameplate shall include a transformer outline drawing showing the location of all valves, and a chart identifying the type, size and purpose of each valve and specifying the initial position of each valve for the field oil-filling procedure and the position of each valve when the transformer is energized.

10.5 Field Oil-Filling Procedure Nameplate

For a transformer with a conservator system, a separate nameplate describing the field oil-filling procedure, titled “Field Oil-Filling Procedure”, shall be furnished and mounted externally near the main transformer nameplate in a location to permit reading from the ground. The nameplate shall include the following from Section 8.14 of this document: the complete procedure as listed in steps 1 through 17, the valve location schematic drawing as shown in Figure 5, and the list of initial valve positions as shown in Table 3. In the list of initial valve positions, the supplier’s valve numbers (from the supplier’s drawings) shall be shown next to the corresponding PacifiCorp valve numbers 1 through 10.



ZS 001

Page 40 of 70

31 Oct 07

**Substation Equipment—
Power Transformer, All
Ratings**

**MATERIAL SPECIFICATION
Substations and High-
Voltage Equipment**

© 2007 by PacifiCorp. All rights reserved.

Engineer (M. Weisensee):

Standards Manager (G. Lyons):

11 Finish Requirements

11.1 Tank Exterior Finish and Porcelain Color

The transformer tank exterior paint finish, the surge arrester ground-bus-bar paint finish, and all bushing and surge arrester porcelain shall be Munsell 5.0 BG 7.0/0.4 light gray. The exterior paint on the transformer cover shall be a nonskid composition.

11.2 Tank Interior Finish

The transformer tank interior and winding clamps shall be painted white.

12 Special Test Requirements, Measurements, and Calculations

12.1 General

All applicable standard and special test requirements shall apply to each transformer, whether manufactured separately or at the same time as other identical units. All test results, measurements, and calculated values shall be recorded on the supplier's certified test report. All data shall be reviewed by the supplier before the transformer is shipped.

If a Y-winding is specified, whether the terminals are specified to be brought out or buried, the Y-winding voltage and capacity ratings shall be shown on the test report.

12.2 Test Sequence

The temperature tests, if specified in Section 17.28 of this document, Table 16 or Table 17, shall precede all dielectric tests.

The lightning impulse tests or quality control lightning impulse tests as applicable, if required by standards or specified in Section 17.28 of this document, Table 16, shall precede the low-frequency dielectric tests.

The switching impulse tests, if specified in Section 17.28 of this document, Table 17, shall precede the low-frequency dielectric tests.

The final dielectric test(s) performed shall be the induced voltage test(s).

12.3 Surge Protection Devices

Internal or external surge protection devices (varistors) shall not be used during transformer testing (see Section 4.11 of this document). The supplier shall include in the proposal a statement confirming compliance with this requirement.

12.4 Test Bushings

The bushings installed for transformer tests shall be those that will be furnished with the transformer.

**MATERIAL SPECIFICATION
Substations and High-
Voltage Equipment**

© 2007 by PacifiCorp. All rights reserved.

Engineer (M. Weisensee): *MW*
Standards Manager (G. Lyons): *GL*

**Substation Equipment—
Power Transformer, All
Ratings**



31 Oct 07

ZS 001
Page 41 of 70

ZS 001

12.5 Dissolved Gas Analysis

A dissolved gas analysis shall be performed on transformer oil samples taken (1) after the unit is filled and before any tests are performed, (2) immediately after the temperature tests at the maximum force-cooled rating, if temperature tests are performed (see Section 17.28 of this document, Table 16 or Table 17), (3) immediately after temperature tests at 125% of the maximum force-cooled rating, if this overload test is performed (see Section 12.14.2 of this document), and (4) after all tests have been completed, except the unintentional-core-ground test (see Section 12.23 of this document).

The total measured levels of gasses generated during the temperature tests, sample (2) levels minus sample (1) levels, and sample (3) levels minus sample (1) levels, shall not exceed the limits specified below in Table 4.

Table 4 - Dissolved Gas Limits

Gas	Maximum Level (PPM)	Overload Maximum Level (PPM)
	Sample (2) minus Sample (1)	Sample (3) minus Sample (1)
Hydrogen (H ₂)	10	10
Carbon Dioxide (CO ₂)	200	300
Carbon Monoxide (CO)	20	30
Methane (CH ₄)	2	2
Ethane (C ₂ H ₆)	1	1
Ethylene (C ₂ H ₄)	non-detectable	non-detectable
Acetylene (C ₂ H ₂)	non-detectable	non-detectable

12.6 Gas Collection Tests

If a conservator oil preservation system is specified by PacifiCorp or selected by the supplier, gas collection test provisions shall be furnished and tests performed as described below. A temporary fitting for gas injection shall be installed at each corner of the tank near the top of the tank wall; these fittings shall be welded closed after the completion of testing. Four separate gas collection tests shall be performed, using in turn the gas injection fitting furnished at each corner of the tank. With the oil circulating pumps turned off and without prior injection of nitrogen, each test shall be performed by rapidly injecting (within 20 seconds) 200 cc of dry nitrogen into one of the gas injection fittings. Each individual test is successful if a minimum of 100 cc of nitrogen collects in the gas detector chamber within two minutes after injection. (See Section 8.11.3.2 of this document.)

12.7 Positive-Sequence Impedance

Impedance shall be measured on all series, parallel, delta, and wye connections, as applicable. The H-winding to X-winding positive-sequence impedance shall be measured at the nominal rated voltage and de-energized tap extremes with the LTC at neutral, and at



the LTC tap extremes with the de-energized tap changer at the nominal rated voltage connection. If the Y-terminals are specified to be brought out (see Section 17.13 of this document), the positive-sequence impedance to the Y-winding shall be measured at the nominal rated voltage, and at the de-energized tap extremes and LTC tap extremes.

12.8 Zero-Sequence Impedance

Zero-sequence impedances (both R and X values) shall be measured if the transformer is three-phase core form.

12.9 No-Load Loss and Excitation Current

No-load loss and excitation current shall be measured both at nominal rated voltage and at 110 percent of nominal rated voltage, both before and after impulse tests.

12.10 Loss Compliance

Values of no-load loss and excitation current measured at nominal rated voltage after impulse tests shall be the values used in determining compliance with the supplier’s quoted loss and excitation performance. These values shall not exceed the values measured before impulse tests by more than 7.5 percent.

IEEE tolerances from the supplier’s performance quotation for no-load loss at nominal rated voltage shall also apply to the excitation current at nominal rated voltage.

If LTC equipment is specified in Section 17.14 of this document, both no-load and total losses quoted in the supplier’s proposal shall be the average of respective losses at five LTC positions: (1) neutral (nominal rated voltage), (2) maximum lower, (3) one position above maximum lower, (4) maximum raise, and (5) one position below maximum raise position.

No supplier shall ship to PacifiCorp a transformer that exceeds the quoted loss value by 10% or more for no-load losses (NL) or load losses (LL) or by 6% or more for total losses (NL + LL).

12.11 Insulation Resistance

Insulation resistance shall be measured at 2.5 kVDC and shall include a 1-minute:10-minute comparative polarization index. The certified test report shall include actual readings and readings corrected to 20 °C. Resistance shall be measured between the windings, and between each winding and ground.

12.12 Power-Factor and Excitation-Current Tests

A power-factor test shall be performed on all windings and bushings at 10 kV. No winding shall exceed a 0.5% power factor. For each H-terminal, and for each H-winding connection if series-parallel, an excitation-current test shall be performed at 10 kV on each de-energized tap with the LTC in the neutral position. The excitation-current test shall also

**MATERIAL SPECIFICATION
Substations and High-
Voltage Equipment**

© 2007 by PacifiCorp. All rights reserved.

Engineer (M. Weisensee): *MW*
Standards Manager (G. Lyons): *GL*

**Substation Equipment—
Power Transformer, All
Ratings**



31 Oct 07

ZS 001
Page 43 of 70

ZS 001

be performed with the LTC in each position from 2-lower through 16-raise with the de-energized tap changer connected at the highest ratio. Both the power-factor and the excitation-current tests shall be performed using Doble procedures and format. The supplier shall include the original electronic power-factor and excitation-current test results in Doble software format with the certified test report.

12.13 Auxiliary Wiring

Auxiliary wiring shall be tested with 60-hertz voltage of 1500 volts applied for 60 seconds. Test jigs may be used to apply the test voltage to multiple terminals at the same time. "Touch testing" for periods less than 60 seconds is not acceptable.

■ CT wiring shall be tested with 60-hertz voltage of 2500 volts applied for 60 seconds.

12.14 Temperature Tests

12.14.1 General Test Requirements

The winding average temperature rise for each phase of each winding shall be separately measured at the self-cooled rating and at the maximum forced-cooled rating, as applicable. If any temperature rise on one phase exceeds the corresponding temperature rise on any other phase by more than 4°C, PacifiCorp shall be consulted and further investigative tests shall be performed as necessary.

In addition to all standard temperature test data, the supplier shall furnish the bottom-oil temperature rise corresponding to each value of top-oil temperature rise. The supplier shall also furnish the calculated winding hot-spot temperature rise corresponding to the highest measured value of winding average temperature rise at both the self-cooled rating and the maximum forced-cooled rating.

12.14.2 Special Additional Test Requirements

If the H-terminals are rated for a nominal system voltage of 115 kV or above, and the rated self-cooled capacity is 12 MVA or above, the duration of the temperature test at the maximum forced-cooled rating (including full representation of the total losses at this rating) shall be a minimum of eight hours, with the eight-hour period starting when the top-oil rise has stabilized (as determined by IEEE C57.12.90).

Following the shutdown for measurements, the test shall be immediately resumed at 125% of the maximum forced-cooled rating (including full representation of the increased total losses at this overload rating) and continued for a minimum of eight additional hours, including the time necessary to reach thermal stability. At the conclusion of the test, measurements shall again be made and winding temperature rises determined.

During the 125% overload test, the transformer shall meet the following requirements:



ZS 001

Page 44 of 70

31 Oct 07

**Substation Equipment—
Power Transformer, All
Ratings**

**MATERIAL SPECIFICATION
Substations and High-
Voltage Equipment**

© 2007 by PacifiCorp. All rights reserved.

Engineer (M. Weisensee):

Standards Manager (G. Lyons):

1. The hot-spot winding temperature rise shall not be greater than 110°C.
2. The top-oil temperature rise shall not be greater than 80°C.

During the period of thermal stability just before shutdown at the end of the eight-hour overload portion of the test, an infrared scan of all four segments of the tank and cover shall be performed. The measured temperatures of the tank and cover shall not exceed 80°C rise above the ambient air temperature.

12.15 Test Data Required for Temperature Monitor

To facilitate setting the advanced winding hot-spot temperature elements in the Qualitrol temperature monitor (see Section 5.1.4 of this document), the supplier shall complete a reproduction of the following table with the specified temperature test data and attach the table to the certified transformer test report.

Table 5 - Qualitrol Temperature Monitor, Table of Temperature Test Data

MVA	Temperature (Degrees C)			Time (Minutes)
	Top-Oil Temperature Rise	Ambient Temperature	Winding Hot-Spot Temperature Rise	
Self-Cooled Rating	(a)	(b)	(c)	(d)
Maximum Forced-cooled Rating	(e)	(f)	(g)	(h)

- (a) and (e): The top-oil temperature rise above ambient temperature at the specified MVA rating.
- (b) and (f): The ambient temperature at the time of measuring the temperature rises at the specified MVA rating.
- (c) and (g): The winding hot-spot temperature rise above ambient temperature at the specified MVA rating.
- (d) and (h): The time required to reach 63.2% of the final winding temperature rise at the specified MVA rating (also known as the winding temperature time constant value).

12.16 Lightning Impulse

For a Class I transformer, lightning impulse tests or supplier’s quality control lightning impulse tests shall be performed if specified in Section 17.28 of this document, Table 16.

(Note that if the transformer is Class II, IEEE standards require lightning impulse tests as routine.)

12.17 Switching Impulse

If specified in Section 17.28 of this document, Table 17, IEEE switching impulse tests shall be performed.

**MATERIAL SPECIFICATION
Substations and High-Voltage Equipment**

© 2007 by PacifiCorp. All rights reserved.

Engineer (M. Weisensee): *MW*
Standards Manager (G. Lyons): *GL*

**Substation Equipment—
Power Transformer, All
Ratings**



31 Oct 07

ZS 001
Page 45 of 70

ZS 001

12.18 Induced Voltage Tests and Partial Discharge Measurement

12.18.1 Partial Discharge Measurement

Partial discharge shall be measured both in terms of the radio-influence voltage (in microvolts) and in terms of the apparent charge (in picocoulombs).

12.18.2 Class I Transformer

Partial discharge shall be measured during the 7200-cycle induced voltage tests if specified in Section 17.28 of this document, Table 16. The instrumentation for measurement shall be the same as that used for a Class II transformer. The measured partial discharge shall not exceed 200 microvolts and 500 picocoulombs.

A combined 7200-cycle and one-hour induced voltage test with partial discharge measurement shall be performed if specified in Section 17.28 of this document, Table 16. The test procedure shall be the same as that used for a Class II transformer. The measured partial discharge shall not exceed 200 microvolts and 500 picocoulombs during the enhancement level, and 100 microvolts and 300 picocoulombs during the one-hour level.

12.18.3 Class II Transformer

A combined 7200-cycle and one-hour induced voltage test with partial discharge measurement is required by IEEE standards as routine. The measured partial discharge shall not exceed 200 microvolts and 500 picocoulombs during the enhancement level, and 100 microvolts and 300 picocoulombs during the one-hour level.

12.19 Short-Circuit Testing

At PacifiCorp's option, the transformer supplied under this specification may be short-circuit tested in accordance with IEEE C57.12.90, at a location of PacifiCorp's choice.

12.20 Audible Sound Level

If specified in Section 17.28 of this document, Table 16 or Table 17, the following sound level tests shall be performed: (1) average audible sound level tests (a) without forced-cooling equipment in operation and (b) with forced-cooling equipment in operation for each forced-cooled capacity rating, and (2) one-third octave-band audible sound level test at maximum forced-cooled capacity rating for mid-band frequency of 125 Hz. If LTC is specified in Section 17.14 of this document, and the LTC being furnished is a reactance type, sound level tests shall be performed with the LTC reactor energized, and at the maximum bridging turn tap.

12.21 Tap Changer Continuity Test

Supplier shall perform a tap changer continuity test to verify proper LTC lead connection.



ZS 001

Page 46 of 70

31 Oct 07

**Substation Equipment—
Power Transformer, All
Ratings**

**MATERIAL SPECIFICATION
Substations and High-
Voltage Equipment**

© 2007 by PacifiCorp. All rights reserved.

Engineer (M. Weisensee):

Standards Manager (G. Lyons):

12.22 Frequency Response Analysis

A frequency response analysis (FRA) shall be performed at the factory after all other tests have been completed (except the unintentional-core-ground test; see Section 12.23 of this document), prior to disassembling the transformer for shipment. An FRA shall again be performed by the supplier in the field after the transformer has been completely reassembled and prepared for energization. Doble equipment shall be used for all FRA measurements. Supplier shall include the original FRA electronic test results in Doble software format with the certified test report.

The FRA test shall be done per the Doble Power Transformer - Test Specification, Transformer Frequency Response Analysis (FRA) Test.

Prior to acceptance of the transformer by PacifiCorp, the two sets of FRA measurements shall be compared and analyzed to ensure compliance with Doble criteria as indication that the transformer has not been damaged during shipment.

12.23 Unintentional Core Ground

A final test for unintentional core grounds shall be performed after all other tests are complete and as late as practical in the handling sequence prior to shipment.

13 Technical Documentation

Drawings shall be full size (not reduced). All wording on drawings and other information shall be in English only; all numerical values shall be in U.S. customary units only, or in both U.S. customary and SI units.

The PacifiCorp PM order number, PO number, equipment number, and installation location, all specified in Section 17.1.1 of this document, shall be shown in the title block on drawings, and in the title heading on other information.

Each item identification number on the transformer and component outline drawings shall be enclosed in a small circle and located outside the outline of the equipment for convenient reading and to avoid confusion with dimensions and other data. A fine line shall be drawn to connect each item identification number to the associated item on the equipment.

13.1 Technical Documentation for Approval

If specified in Section 17.1.4 of this document, the following shall be furnished for approval, and shall be sent to PacifiCorp as specified in Section 17.1.6 of this document.

1. Three sets of printed copies of applicable drawings and other information from Section 13.3 of this document.
2. One compact disc (CD) of applicable drawings in AutoCAD, or in DXF file format if not available in AutoCAD.

**MATERIAL SPECIFICATION
Substations and High-
Voltage Equipment**

© 2007 by PacifiCorp. All rights reserved.

Engineer (M. Weisensee):

Standards Manager (G. Lyons):

MW
GL

**Substation Equipment—
Power Transformer, All
Ratings**



31 Oct 07

ZS 001
Page 47 of 70

ZS 001

13.2 Final Technical Documentation

For the temperature monitor (see Section 5.1.4 of this document), one electronic copy on compact disc (CD) of the configuration software and the configuration file, and one copy of associated printed information as necessary, shall be sent to PacifiCorp as specified in Section 17.1.6 of this document.

Applicable final drawings, instruction manuals, test reports, and all other information from Section 13.3 of this document shall be furnished as specified in the following list.

1. One set of final drawings, instruction manuals, test reports and all other information specified in Section 13.3 of this document shall be shipped with the transformer in a weatherproof envelope or in a compartment.
2. Five additional sets of final drawings, instruction manuals, test reports, and all other information specified in Section 13.3 of this document shall be sent to PacifiCorp as specified in Section 17.1.6 of this document.
3. Two additional sets of final drawings in AutoCAD file format (or in DXF file format if not available in AutoCAD), instruction manuals, test reports, and all other information specified in Section 13.3 of this document shall be furnished on two separate compact discs (CDs) and sent to PacifiCorp as specified in Section 17.1.6 of this document.

13.3 Technical Documentation Description

13.3.1 Certification of Insulating Oil

The supplier shall furnish certification that the insulating oil used to fill the transformer for testing, and the oil supplied with the unit if applicable, contains less than 1.0 ppm polychlorinated biphenyl contamination.

13.3.2 Certified Test Report

The supplier shall furnish a complete certified test report (see Section 12.1 of this document).

13.3.3 Outline Drawing

The supplier shall furnish an assembled transformer outline drawing. Information shown on the drawing shall include the following items in addition to or in clarification of the information normally included.

1. Structural details of the transformer base
2. Weight and center of gravity of the installed unit and the unit prepared for shipment
3. Minimum dimensions of the unit prepared for shipment
4. Foundation reactions produced by equipment operation, and by wind and seismic forces



ZS 001

Page 48 of 70

31 Oct 07

**Substation Equipment—
Power Transformer, All
Ratings**

**MATERIAL SPECIFICATION
Substations and High-
Voltage Equipment**

© 2007 by PacifiCorp. All rights reserved.

Engineer (M. Weisensee):

Standards Manager (G. Lyons):

13.3.4 Nameplate and Instruction Plate Drawings

The supplier shall furnish a drawing of each nameplate and instruction plate.

13.3.5 Bushing Outline Drawings

The supplier shall furnish detailed bushing outline drawings.

13.3.6 Surge Arrester Outline Drawings

The supplier shall furnish detailed surge arrester outline drawings.

13.3.7 Schematic and Wiring Diagrams

The supplier shall furnish schematic and wiring diagrams showing complete auxiliary equipment wiring, including: (1) customer connection points, (2) the number, size, and power requirements of fans and pumps, (3) the fan and pump control, (4) the alarm and relay connections, (5) the current transformer connections, and (6) the load tap changing equipment control.

13.3.8 Current Transformer Nameplate Drawings

The supplier shall furnish current transformer nameplate drawings or include this information on the main transformer nameplate drawing.

13.3.9 Current Transformer Information

The supplier shall furnish the following: (1) current transformer resistance per winding turn, (2) resistance of each lead, (3) curves showing ratio correction and secondary excitation for relaying, and (4) curves showing ratio and phase angle correction for metering.

13.3.10 Instruction Manuals

The supplier shall furnish instruction manuals covering the receiving, handling, installation, operation, and maintenance of the transformer and all auxiliary equipment.

13.3.11 Renewal Parts

The supplier shall furnish a complete list of renewal parts for the transformer and all auxiliary equipment, including identification of each part by name and part number. The renewal parts list for LTC equipment shall be accompanied by detailed drawings and exploded views as required to facilitate complete maintenance by PacifiCorp. Parts lists and drawings shall relate specifically to the equipment covered by this specification; typical drawings are not acceptable.

14 Shipping Requirements

14.1 Air-filled or Oil-filled

As specified in Section 17.34 of this document, the transformer prepared for shipment shall be filled with oil and with dry nitrogen in the gas space at a pressure of three psig, or shall be

MW
GL

ZS 001

filled with dry breathable air at a pressure of three psig (see Sections 8.10 and 16.7 of this document). A conspicuous tag shall be furnished identifying the gas contents of the transformer prepared for shipment and specifying the actual gas pressure and the ambient temperature at the time of filling.

14.2 Factory Assembly and Component Location Marking

The complete transformer, including all auxiliary power and control wiring, shall be completely assembled at the factory to ensure proper fit and operation of all components.

Major transformer components that must be shipped detached for field installation (including, but not limited to, components such as radiators, pumps, conservator supports, and surge arrester supports) shall be marked for installation by means of permanent metal stamping. This metal stamping shall include adjacent marks on the component and the main transformer assembly to show both component location and orientation.

14.3 Shipping Dimensions and Weight

The supplier shall be responsible for checking the shipping dimensions and weight of the proposed transformer design for suitability for shipment to the specified destination.

14.4 Notice of Shipment

The supplier shall notify PacifiCorp two weeks prior to the expected arrival of the transformer. Additionally, the PacifiCorp contact person named in Section 17.1.8 of this document, shall be notified on the day of shipment and 48 hours prior to the delivery of the transformer to ensure provisions for unloading.

14.5 Impact Recorders

For all modes of shipment, two impact recorders shall be furnished and installed by the supplier. Each impact recorder shall be furnished with a sealed protective cover. The two event recorders for truck shipment shall be installed at a 90-degree angle to each other. Impact recorders furnished by the railroad will not be acceptable. Not less than one hour prior to scheduled pickup of the transformer or truck, the supplier shall start the recorders and verify they are operating properly. The impact recorders shall provide a continuous record covering the entire shipment period. The impact recorder charts, or electronic record if applicable, shall become the property of PacifiCorp at the time of delivery.

14.6 Rail Shipment

14.6.1 Rider

For shipment by rail, PacifiCorp may employ a qualified rider to accompany the shipment.

14.6.2 Unloading Allowance

For shipment by rail, three normal working days, Monday through Friday, shall be allowed for unloading the transformer from the railcar.



Substation Equipment— Power Transformer, All Ratings

MATERIAL SPECIFICATION Substations and High- Voltage Equipment

© 2007 by PacifiCorp. All rights reserved.

Engineer (M. Weisensee): *MGW*
Standards Manager (G. Lyons): *GL*

ZS 001

Page 50 of 70

31 Oct 07

14.7 Supplier Representative

If specified in Section 17.1.9 of this document, the supplier shall furnish a mutually agreed upon representative to be present at the delivery site to verify the transformer condition as received, before unloading from the railcar. This representative shall (1) sign any impact recorder chart(s), (2) witness unintentional-core-ground testing, and (3) verify the internal inspection findings.

15 Other Inspection Requirements

15.1 Design Review

If specified in Section 17.1.7 of this document, a design review will be conducted upon completion of the transformer design. PacifiCorp may employ a consultant as its agent to oversee the review. The supplier shall include in the quoted schedule sufficient time for the review, and shall not order transformer materials prior to completion of the review without the written approval of PacifiCorp.

If the transformer design is found to be unacceptable to PacifiCorp, the right is reserved to cancel the order at that time, with financial responsibility only for such reasonable design costs as have been incurred to that time.

15.2 Quality Surveillance

A quality surveillance representative (QSR) may be employed by PacifiCorp to be present at the supplier’s facility during the manufacturing and testing of the transformer. If a QSR is employed, the QSR will comply with the supplier’s safety and procedural requirements at all times while in the supplier’s facility, and the following additional guidelines shall apply.

15.2.1 Cooperation with Quality Surveillance Representative

The supplier shall cooperate with the QSR and arrange a reasonable and mutually agreeable schedule for the required inspections and witnessing of tests, consistent with maintaining scheduled progress of the transformer through the supplier’s facility.

15.2.2 Authority of Quality Surveillance Representative

The QSR will have full authority from PacifiCorp to make whatever decisions are necessary to ensure that the complete transformer equipment complies with all requirements of PacifiCorp’s procurement documents, and to ensure that all required inspection and witness activities are carried out.

15.2.3 Disagreements

In the event of significant disagreement between the supplier and the QSR concerning scheduling of inspection or witness activities, or concerning interpretation of PacifiCorp’s procurement documents, the supplier and the QSR shall promptly and jointly contact PacifiCorp to resolve the matter.

MW
GL

ZS 001

15.3 Field Engineer

Services of the supplier's field engineer(s), if specified in Section 17.1.10 of this document, shall be furnished for supervision of field installation of all parts detached for shipment, and for complete pre-energization inspection of the transformer. The field engineer(s) shall have a thorough working knowledge of the complete transformer (all internal and external components, including load tap changing equipment).

16 Evaluation

16.1 Product Evaluation

PacifiCorp may evaluate the supplier and the quality of the supplier's transformers by using a systematic evaluation process established by PacifiCorp.

16.2 Loss Evaluation Method

An Equivalent Total Owning Cost (*ETOC*) will be calculated from the bid price and the present value of the supplier's guaranteed maximum losses as shown below. The *ETOC* will be used in determining bid awards.

$$ETOC = BID\ PRICE + (A \times NL) + (B \times LL) + (C \times AP)$$

where:

- ETOC* = Equivalent total owning cost in dollars
- BID PRICE* = Supplier-quoted bid price in dollars
- A* = Loss cost multiplier for no-load losses in dollars per watt
- B* = Loss cost multiplier for load losses in dollars per watt
- C* = Cost multiplier for auxiliary power in dollars per watt
- NL* = Guaranteed maximum no-load losses at 20° C in watts
- LL* = Guaranteed maximum load losses at 85° C in watts, excluding auxiliary power (The load losses shall be quoted at the self-cooled rating for a substation transformer with radiators. For a substation transformer with coolers instead of radiators, or for any generator step-up transformer (whether with coolers or with radiators), the load losses shall be quoted at the maximum forced-cooled rating.)
- AP* = Guaranteed maximum auxiliary power requirement in watts (with all forced-cooling equipment in service)

16.3 Loss Cost Multipliers

The loss cost multipliers to be used in the loss evaluation method will be as specified in Section 17.2 of this document.



16.4 Loss Penalty

In the event that the combined evaluated cost of actual tested no-load losses (NL), load losses (LL), and auxiliary power (AP) exceeds the combined evaluated cost of the respective guaranteed maximum losses and auxiliary power, credit shall be given to PacifiCorp for the dollar difference. Any dollar difference shall be deducted from the transformer invoice by the supplier.

16.5 Shipping Cover

PacifiCorp prefers that the transformer be shipped in its own complete tank. If a shipping cover must be employed, the supplier shall clearly state that fact in the proposal and shall quote a separate cost for the supplier to remove the shipping cover and install the permanent welded cover at the job site; PacifiCorp will apply this cost as an addition to the equivalent total owning cost (see Section 16.2 of this document). PacifiCorp will also apply an additional \$15000 to the equivalent total owning cost for added PacifiCorp labor requirements and inconveniences associated with the shipping cover.

16.6 Horizontal Shipment

PacifiCorp prefers that the transformer be shipped in the upright position. If horizontal shipment must be employed, the supplier shall clearly state that fact in the proposal. If horizontal shipment is intended, PacifiCorp will apply an additional cost to the equivalent total owning cost (see Section 16.2 of this document) for added PacifiCorp labor requirements and inconveniences associated with uprighting the transformer. The additional cost, based on the size of crane required, will be as follows:

Crane size: 45-ton or below	\$ 5000
Crane size: 46-ton to 90-ton	\$10000
Crane size: above 90-ton	\$15000
<i>Plus</i> use of leveraged uprighting rocker shoes	\$ 5000

16.7 Method of Shipment

A transformer with the H-terminals rated for a nominal system voltage of 161 kV or above shall be shipped without oil and filled with dry breathable air.

The method of shipment for a transformer with the H-terminals rated for a nominal system voltage below 161 kV shall be as specified below:

1. A transformer with a self-cooled rating above 18000 kVA shall be shipped without oil and filled with dry breathable air.
2. For a transformer with a self-cooled rating of 18000 kVA or below and above 12000 kVA, it is preferred that shipment be made by truck, oil filled.
3. A transformer with a self-cooled rating of 12000 kVA or below shall be shipped by truck, oil filled.

**MATERIAL SPECIFICATION
Substations and High-
Voltage Equipment**

© 2007 by PacifiCorp. All rights reserved.

Engineer (M. Weisensee): *MW*
Standards Manager (G. Lyons): *GL*

**Substation Equipment—
Power Transformer, All
Ratings**



31 Oct 07

ZS 001
Page 53 of 70

ZS 001

PacifiCorp will apply an additional cost to the equivalent total owning cost (see Section 16.2 of this document) for the method of shipment as follows:

- Shipment by truck, oil filled \$ -0-
- Shipment by truck, without oil \$15000
- Shipment by rail, oil filled \$10000
- Shipment by rail, without oil \$25000

17 Additional Transformer-Specific Requirements

The transformer information and specifications in this section are for the equipment referenced in Section 17.1.1 of this document, and shall be used in conjunction with the other requirements of this material specification.

In this section, a box checked (✓) next to an item indicates that the item is required or applicable; a box not checked indicates that the item does not apply or is not acceptable.

17.1 Equipment Identification and Order Requirements

17.1.1 Equipment Identification

PM Order number: _____
REQ number: _____ PO number: _____
Equipment number(s): _____
Location: _____

17.1.2 Commercial Issues

Correspondence regarding commercial issues shall be sent to the PacifiCorp purchasing department, with copies to:

Project engineer: _____
Address: _____
City: _____ State: _____ Zip: _____
Telephone: _____

17.1.3 Technical Issues

Technical questions regarding this material specification, or notice of any other technical issues that arise during the proposal process or during equipment design, manufacture, or test, shall be directed to the project engineer (see Section 17.1.2 of this document).

17.1.4 Approval Drawings

If checked (✓), drawings and other information shall be furnished for approval (see Section 13 of this document)



Approval drawings on compact disc (CD) shall be as checked (✓) below:

- AutoCAD version _____
- DXF file format

17.1.5 Final Drawings on Compact Disc (CD)

If checked (✓), one additional set of final drawings shall be furnished on a compact disc (CD) as specified (see Section 13 of this document):

- AutoCAD version _____
- DXF file format

17.1.6 Drawing Destination

All drawings and other information specified in Section 13 of this document shall be mailed to the person in the department checked (✓) below:

- PacifiCorp Asset Management Document Services
Lloyd Center Tower
825 NE Multnomah St., Suite 1600
Portland, OR97232

17.1.7 Design Review

If checked (✓), a design review will be conducted as specified in Section 15.1 of this document

17.1.8 Notice of Shipment

The supplier shall notify the person named below, as specified in Section 14.4 of this document.

Name: _____

Address: _____

City: _____ State: _____ Zip: _____

Telephone: _____

17.1.9 Supplier Representative

If checked (✓), the supplier shall furnish a mutually agreed upon representative to be present at the delivery site as specified in Section 14.7 of this document. .

17.1.10 Field Engineer

If checked (✓), the supplier’s field engineer(s) shall furnish supervision for field installation as specified in Section 15.3 of this document.

17.2 Loss Cost Multipliers

The loss cost multipliers are as follows (see Section 16.2 of this document):

**MATERIAL SPECIFICATION
Substations and High-
Voltage Equipment**

© 2007 by PacifiCorp. All rights reserved.

Engineer (M. Weisensee): *MW*
Standards Manager (G. Lyons): *GL*

**Substation Equipment—
Power Transformer, All
Ratings**



31 Oct 07

ZS 001
Page 55 of 70

ZS 001

No-load loss cost multiplier (A) = \$_____ / watt

Load loss cost multiplier (B) = \$_____ / watt

Auxiliary power cost multiplier (C) = \$_____ / watt

17.3 Contaminated Environment Protection

If checked (✓), the transformer shall be suitable for operation in contaminated environments as specified in Section 4.15 of this document.

17.4 Service Class

The transformer shall be suitable for the class of service checked (✓) below.

Distribution or transmission substation

Generator step-up

Mobile substation

Phase-angle regulation

17.5 Design Form

The transformer design form shall be as checked (✓) below.

Core-form

Shell-form

Core-form or shell-form (supplier's choice)

17.6 Elevation

The transformer shall be designed for special high-elevation operation without derating, up to the specified elevation, if checked (✓) below.

_____ feet

17.7 Ambient Temperature

The transformer shall be designed for special low-temperature and/or high-temperature operation without derating if checked (✓) below.

-50°C daily minimum

-40°C daily minimum

+45°C daily peak

17.8 Phase Designation

The phase of the transformer shall be as checked (✓) below.

Single-phase

Three-phase

17.9 Winding Type

The transformer winding type shall be as checked (✓) below.



Substation Equipment— Power Transformer, All Ratings

MATERIAL SPECIFICATION Substations and High- Voltage Equipment

© 2007 by PacifiCorp. All rights reserved.

Engineer (M. Weisensee): *MGW*
Standards Manager (G. Lyons): *GL*

ZS 001

Page 56 of 70

31 Oct 07

- Two-winding
- Three-winding
- Three-winding autotransformer

17.10 Winding Designation

The IEEE winding designation shall be as follows:

- H-winding _____
- X-winding _____
- Y-winding _____

17.11 Cooling Class

The cooling class shall be as checked (✓) below:

- Self-cooled rating
 - ONAN
- Self-cooled rating and one forced-cooled rating
 - ONAN / ONAF
- Self-cooled rating and two forced-cooled ratings
 - ONAN / ONAF / ONAF
 - ONAN / ONAF / ODAF
 - ONAN / ODAF / ODAF
 - One of the classes checked above (supplier's choice)
- One forced-cooled rating (no self-cooled rating)
 - ODAF
 - ODWF
- Two forced-cooled ratings (no self-cooled rating)
 - ODAF / ODAF
 - ODWF / ODWF
- Other class, as follows:

17.12 Capacity Ratings

The capacity ratings at 65° C average winding temperature rise for the H-, X-, and Y-terminals, as applicable, shall be as specified in the rows checked (✓) below in Table 6.

Table 6 - Transformer Capacity Ratings

Terminals	Self-Cooled (MVA)	First Stage Forced-Cooled (MVA)	Maximum Forced-Cooled (MVA)	(✓)
H & X				<input type="checkbox"/>
Y	See Note 2.			<input type="checkbox"/>
Y				<input type="checkbox"/>

**MATERIAL SPECIFICATION
Substations and High-Voltage Equipment**

© 2007 by PacifiCorp. All rights reserved.

Engineer (M. Weisensee): *MW*
Standards Manager (G. Lyons): *GL*

**Substation Equipment—
Power Transformer, All
Ratings**



31 Oct 07

ZS 001
Page 57 of 70

ZS 001

Note 1. If designated by "***" in the table, the self-cooled and first-stage forced-cooled capacity ratings shall be selected by the supplier and need not be the standard values normally associated with the specified maximum forced-cooled capacity rating(s).

Note 2. If this row is checked, the Y-terminal capacity ratings shall be 35% of the ratings of the H and X terminals, or, for an autotransformer, 35% of the MVA parts of the largest of the series and common windings.

17.13 Voltage and Surge Arrester Ratings

The transformer shall be furnished with the voltage ratings, BIL ratings, de-energized taps, and surge arrester ratings for each terminal designation, specified in the rows and columns checked (✓) below in Table 7. If applicable, specific de-energized tap ratings shall be as specified in Section 17.13.1.

If series-parallel reconnection is specified for a three-phase transformer for H-winding, X-winding, or both windings (see Section 17.13.2 of this document), the two associated voltage ratings for each winding, as applicable, are specified in Table 7. If wye-delta reconnection is specified for a three-phase transformer for H-winding, X-winding, or both windings (see Section 17.13.3 of this document), the voltage rating specified in Table 7 for each winding, as applicable, is for the wye connection.



ZS 001

Page 58 of 70

31 Oct 07

Substation Equipment— Power Transformer, All Ratings

MATERIAL SPECIFICATION Substations and High- Voltage Equipment

© 2007 by PacifiCorp. All rights reserved.

Engineer (M. Weisensee):

Standards Manager (G. Lyons):

Table 7 - Transformer Voltage and Surge Arrester Ratings

(✓) Desired Rating	Nominal System Voltage (kV)	Center Tap Voltage Rating (kV)	De-energized Taps ^{NO TAG} (yes/no)	Winding BIL (kV crest)	Arrester Duty Cycle Rating (kV)		Maximum Continuous Operating Voltage (MCOV) (kV)	
					Grounded System	Ungrounded System	Grounded System	Ungrounded System
H _{1,2,3} or H ₁ Terminal(s)					Station Class			
<input type="checkbox"/>	525			1425	n/a	n/a	n/a	n/a
<input type="checkbox"/>	345			1050	<input type="checkbox"/> 264	n/a	212	n/a
<input type="checkbox"/>	230			750	<input type="checkbox"/> 180	n/a	144	n/a
<input type="checkbox"/>	161			650	<input type="checkbox"/> 132	n/a	106	n/a
<input type="checkbox"/>	138			550	<input type="checkbox"/> 120	n/a	98	n/a
<input type="checkbox"/>	115			450	<input type="checkbox"/> 96	<input type="checkbox"/> 120	76	98
<input type="checkbox"/>	69			350	<input type="checkbox"/> 60	<input type="checkbox"/> 72	48	57
<input type="checkbox"/>	46			250	<input type="checkbox"/> 39	<input type="checkbox"/> 48	31.5	39
<input type="checkbox"/>	34.5			200	<input type="checkbox"/> 30	<input type="checkbox"/> 36	24.4	29
<input type="checkbox"/>								
H ₀ , H ₀ X ₀ , H ₂ or H ₂ X ₂ Terminal					Station Class			
<input type="checkbox"/>	n/a	n/a	n/a		n/a		n/a	
X _{1,2,3} or X ₁ Terminal(s)					Station Class			
<input type="checkbox"/>	345			1050	<input type="checkbox"/> 264	n/a	212	n/a
<input type="checkbox"/>	230			750	<input type="checkbox"/> 180	n/a	144	n/a
<input type="checkbox"/>	161			650	<input type="checkbox"/> 132	n/a	106	n/a
<input type="checkbox"/>	138			550	<input type="checkbox"/> 120	n/a	98	n/a
<input type="checkbox"/>	115			450	<input type="checkbox"/> 96	<input type="checkbox"/> 120	76	98
<input type="checkbox"/>	69			350	<input type="checkbox"/> 60	<input type="checkbox"/> 72	48	57
<input type="checkbox"/>	46			250	<input type="checkbox"/> 39	<input type="checkbox"/> 48	31.5	39
<input type="checkbox"/>	34.5			200	<input type="checkbox"/> 30	<input type="checkbox"/> 36	24.4	29
<input type="checkbox"/>	25.0			150	<input type="checkbox"/> 21	<input type="checkbox"/> 27	17	22
<input type="checkbox"/>	20.8			150	<input type="checkbox"/> 21	<input type="checkbox"/> 27	17	22
<input type="checkbox"/>	13.8			110	<input type="checkbox"/> 12	<input type="checkbox"/> 15	10.2	12.7
<input type="checkbox"/>	13.2			110	<input type="checkbox"/> 12	<input type="checkbox"/> 15	10.2	12.7
<input type="checkbox"/>	13.09			110	<input type="checkbox"/> 12	<input type="checkbox"/> 15	10.2	12.7
<input type="checkbox"/>	12.5			110	<input type="checkbox"/> 12	<input type="checkbox"/> 15	10.2	12.7
<input type="checkbox"/>								
X ₀ or X ₂ Terminal					Station Class			
<input type="checkbox"/>	n/a	n/a	n/a		n/a			
Y _{1,2,3} or Y _{1,2} Terminal(s)					Station Class			
<input type="checkbox"/>	13.8	n/a	n/a	110	n/a	<input type="checkbox"/> 15	n/a	12.7
<input type="checkbox"/>	13.2	n/a	n/a	110	n/a	<input type="checkbox"/> 15	n/a	12.7
<input type="checkbox"/>	12.5	n/a	n/a	110	n/a	<input type="checkbox"/> 15	n/a	12.7
<input type="checkbox"/>		n/a	n/a					
<input type="checkbox"/>	Y terminals buried							

17.13.1 De-Energized Tap Changer

The de-energized tap rating shall be as specified by the row check (✓) in Table 8. See Section 8.2 of this document.

**MATERIAL SPECIFICATION
Substations and High-Voltage Equipment**

© 2007 by PacifiCorp. All rights reserved.

Engineer (M. Weisensee): *MW*
Standards Manager (G. Lyons): *GL*

**Substation Equipment—
Power Transformer, All
Ratings**



31 Oct 07

ZS 001
Page 59 of 70

ZS 001

Table 8 – De-energized Tap Voltage Ratings (kV, L-L)

(✓) Desired Rating	Nominal System Voltage (kV, L-L)	Center Tap Voltage Rating (kV, L-L)	De-energized Tap Voltage Ratings (kV, L-L)
<input type="checkbox"/>	525	525	550 / 537.5 / 525 / 512.5 / 500
<input type="checkbox"/>	345	345	362.25 / 353.625 / 345 / 336.375 / 327.75
<input type="checkbox"/>	230	230	241.5 / 235.75 / 230 / 224.25 / 218.5
<input type="checkbox"/>	161	161	169 / 165 / 161 / 157 / 153
<input type="checkbox"/>	138	138	145 / 141.5 / 138 / 134.5 / 131
<input type="checkbox"/>	115	116	122 / 119 / 116 / 113 / 110
<input type="checkbox"/>	69	67	70.6 / 68.8 / 67 / 65.2 / 63.4
<input type="checkbox"/>	46	46	48.3 / 47.15 / 46 / 44.85 / 43.7
<input type="checkbox"/>	34.5	34.5	36.2 / 35.4 / 34.5 / 33.6 / 32.8
<input type="checkbox"/>			

17.13.2 Series-Parallel Reconnection

If checked (✓), means for series-parallel reconnection shall be furnished for the specified winding(s) as follows. See Section 8.2 of this document.

- H-winding
- Reconnection by a de-energized switch
- Reconnection by a terminal board
- X-winding
- Reconnection by a de-energized switch
- Reconnection by a terminal board

Special requirements:

17.13.3 Wye-Delta Reconnection

If checked (✓), means for wye-delta reconnection shall be furnished for the specified winding(s) as follows. See Section 8.2 of this document.

- ___-winding
- Voltage rating on the wye connection as shown above in Table 7: _____ kV
- Voltage rating on the delta connection: _____ kV



Substation Equipment— Power Transformer, All Ratings

MATERIAL SPECIFICATION Substations and High- Voltage Equipment

© 2007 by PacifiCorp. All rights reserved.

Engineer (M. Weisensee): *MGW*
Standards Manager (G. Lyons): *GL*

Winding BIL on the delta connection: _____ kV
 Reconnection by a de-energized switch
 Reconnection by a terminal board
 ___-winding
 Voltage rating on the wye connection as shown above in Table 7: _____ kV
 Voltage rating on the delta connection: _____ kV
 Winding BIL on the delta connection: _____ kV
 Reconnection by a de-energized switch
 Reconnection by a terminal board
 Special requirements:

17.14 Load Tap Changing Equipment

17.14.1 Load Tap Changing Equipment

If checked (✓), the following LTC equipment shall be furnished in accordance with the requirements of Section 6 of this document. The specified BIL rating is phase-to-phase (for three-phase and three-phase group LTCs) and phase-to-ground, and the specified current rating is the through-current.

The Reinhausen type RMV-II models shown below in Table 9 are three-phase, reactance type, switched in vacuum, mounted on the transformer tank wall.

Table 9 - Reinhausen RMV-II

BIL (kV)	Current (A)	(✓)
110	1500	<input type="checkbox"/>
400	1500	<input type="checkbox"/>
400	2000	<input type="checkbox"/>
		<input type="checkbox"/>

The Waukesha type UZD shown below in Table 10 is three-phase, resistance type, switched in oil, mounted on the transformer tank wall, and may be furnished for Waukesha three-phase transformers only.

Table 10 - Waukesha UZD

BIL (kV)	Current (A)	(✓)
200	600	<input type="checkbox"/>

**MATERIAL SPECIFICATION
 Substations and High-Voltage Equipment**

© 2007 by PacifiCorp. All rights reserved.

Engineer (M. Weisensee): *MW*
 Standards Manager (G. Lyons): *GL*

**Substation Equipment—
 Power Transformer, All
 Ratings**



31 Oct 07

ZS 001
 Page 61 of 70

ZS 001

The Reinhausen type VR model shown below in Table 11 is single-phase (for a single-phase transformer), or three-phase or a three-phase group with a common motor drive (for a three-phase transformer), suspended from the transformer tank cover

Table 11 - Reinhausen VR

Model	BIL (kV)	Current (A)	(✓)
			<input type="checkbox"/>

Supplier's choice of one of the LTCs checked above

17.14.2 Standard Provisions for Remote Control and Indication

If checked (✓), standard provisions for LTC remote control and indication shall be furnished in accordance with the requirements of Section 6.6.1 of this document.

.....

17.14.3 Special Provisions for Remote Control and Indication

If checked (✓), special additional provisions for LTC remote control and indication shall be furnished in accordance with the requirements of Section 6.6.2 of this document.

17.15 Impedance(s)

Transformer impedance(s) shall be as checked (✓) below (see Section 4.7 of this document).

Selected by the supplier

As specified below in Table 12

Table 12 - Transformer Impedance(s)

Winding to Winding	V _{LL}	Percent Impedance	Base kVA
1. H to X	_____ to _____	_____	_____
2. H to Y	_____ to _____	_____	_____
3. X to Y	_____ to _____	_____	_____

17.16 Bank Operation and Parallel Operation

17.16.1 Bank Operation

If the transformer is single-phase, and if checked (✓), the transformer shall be suitable for operation in a three-phase bank with similar transformers as specified in Section 4.8 of this



Substation Equipment— Power Transformer, All Ratings

MATERIAL SPECIFICATION Substations and High- Voltage Equipment

© 2007 by PacifiCorp. All rights reserved.

Engineer (M. Weisensee): *MGW*
Standards Manager (G. Lyons): *GL*

document. The similar transformers are identified below, and the associated impedance test data and nameplate drawings are attached.

17.16.2 Parallel Operation

If the transformer is three-phase, or single-phase operated in a three-phase bank, and if checked () , the transformer or transformer bank shall be suitable for operation in parallel with similar transformer(s) as specified in Section 4.8 of this document. The similar transformer(s) are identified below, and the associated impedance test data and nameplate drawings are attached.

17.17 Polarity or Angular Displacement

If the transformer is single-phase, the polarity shall be subtractive. If the transformer is three-phase, the angular displacement shall be as checked () below in Figure 8.

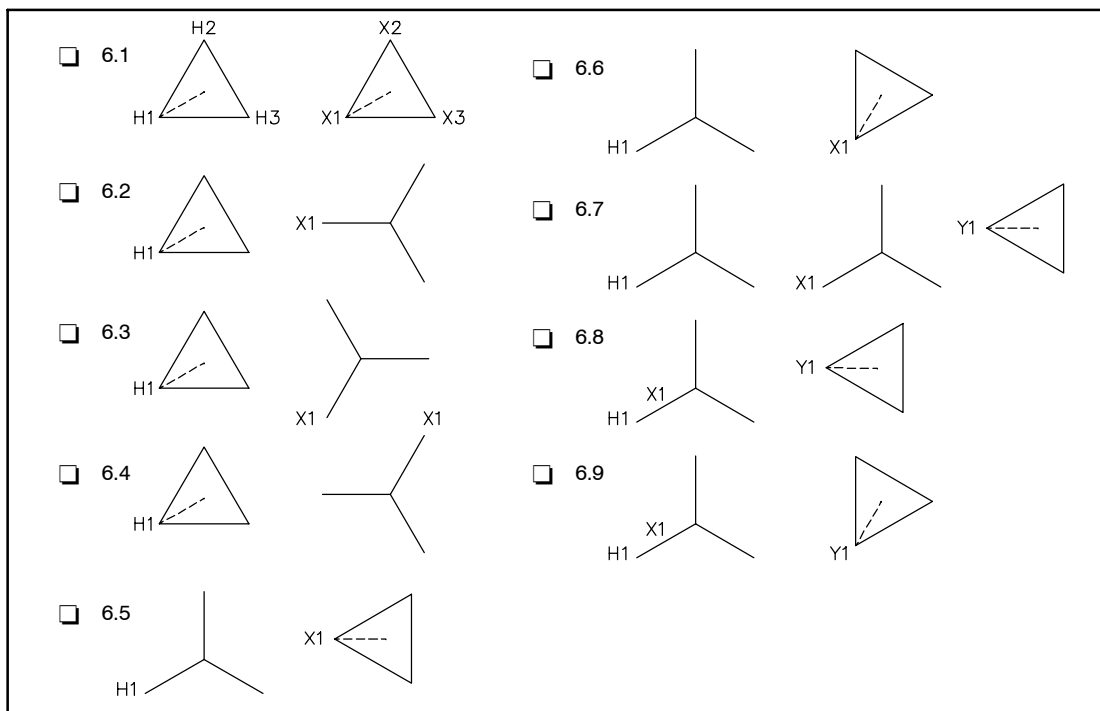

Figure 8 - Three-Phase Transformer Angular Displacement

ZS 001

17.18 Bushing BIL Requirements

The bushing BIL requirements shall be as specified below in Table 13.

Table 13 - Bushing BIL Requirements

<input checked="" type="checkbox"/> Desired Rating	Nominal System Voltage (kV)	Bushing BIL (kV crest)
H _{1,2,3} or H ₁ Terminal(s)		
<input type="checkbox"/>	525	1550
<input type="checkbox"/>	345	1300
<input type="checkbox"/>	230	900
<input type="checkbox"/>	161	750
<input type="checkbox"/>	138	650
<input type="checkbox"/>	115	550
<input type="checkbox"/>	69	350
<input type="checkbox"/>	46	250
<input type="checkbox"/>	34.5	200
<input type="checkbox"/>		
H ₀ , H ₀ X ₀ Terminal(s)		
<input type="checkbox"/>	n/a	
H ₂ , H ₂ X ₂ Terminal(s)		
<input type="checkbox"/>	n/a	
X _{1,2,3} or X ₁ Terminal(s)		
<input type="checkbox"/>	345	1300
<input type="checkbox"/>	230	900
<input type="checkbox"/>	161	750
<input type="checkbox"/>	138	650
<input type="checkbox"/>	115	550
<input type="checkbox"/>	69	350
<input type="checkbox"/>	46	250
<input type="checkbox"/>	34.5	200
<input type="checkbox"/>	25	150
<input type="checkbox"/>	20.8	150
<input type="checkbox"/>	13.8	150
<input type="checkbox"/>	13.2	150
<input type="checkbox"/>	13.09	150
<input type="checkbox"/>	12.5	150
<input type="checkbox"/>		
X ₀ or X ₂ Terminal		
<input type="checkbox"/>	n/a	
Y _{1,2,3} or Y _{1,2} Terminal(s)		
<input type="checkbox"/>	13.8	150
<input type="checkbox"/>	13.2	150
<input type="checkbox"/>	12.5	150
<input type="checkbox"/>		
<input type="checkbox"/>	Y terminals buried	



Substation Equipment— Power Transformer, All Ratings

MATERIAL SPECIFICATION Substations and High- Voltage Equipment

© 2007 by PacifiCorp. All rights reserved.

Engineer (M. Weisensee): *MGW*
Standards Manager (G. Lyons): *GL*

ZS 001

Page 64 of 70

31 Oct 07

17.19 Surge Arrester Discharge Counters

If checked (✓), surge arrester discharge counters shall be furnished as specified in Section 7.2.3 of this document.

17.20 Current Transformers

The supplier shall furnish five-tap multiratio bushing current transformers (BCT) as specified below in Table 14. (See Section 8.5.2 of this document.)

Table 14 - Bushing Current Transformers

Terminals	BCT Position	Full-Winding Amperes	Relaying Accuracy
H _{1,2,3} or H ₁	Top		
H _{1,2,3} or H ₁	Middle		
H _{1,2,3} or H ₁	Middle		
H _{1,2,3} or H ₁	Bottom		
X _{1,2,3} or X ₁	Top		
X _{1,2,3} or X ₁	Middle		
X _{1,2,3} or X ₁	Bottom		
X ₀ or X ₂	n/a		
Y _{1,2,3} or Y ₁	Top		
Y _{1,2,3} or Y ₁	Bottom		
Y ₂	n/a		

The supplier shall also furnish five-tap multiratio current transformer(s) inside the Y-winding delta, if applicable, as specified below in Table 15.

Table 15 - Y-winding Internal Current Transformers

Number	Full-Winding Amperes	Relaying Accuracy

17.21 Resistance Temperature Detector

17.21.1 Main Tank Resistance Temperature Detector

The main tank top-oil resistance temperature detector shall be the model checked (✓) below (see Section 5.1.1 of this document).

- Model 103-045, 10 ohm, copper
- Model 103-044, 100 ohm, platinum (hydroelectric plant transformers *only*) .

**MATERIAL SPECIFICATION
Substations and High-
Voltage Equipment**

© 2007 by PacifiCorp. All rights reserved.

Engineer (M. Weisensee): *MW*
Standards Manager (G. Lyons): *GL*

**Substation Equipment—
Power Transformer, All
Ratings**



31 Oct 07

ZS 001
Page 65 of 70

ZS 001

17.21.2 Ambient Temperature Resistance Temperature Detector

The ambient temperature resistance temperature detector shall be the model checked (✓) below. (See Section 5.1.2 of this document.)

Model 103-026-01, 10 Ohm, copper

Model 103-049-01, 100 Ohm, platinum (hydroelectric plant transformers only)

.....

17.22 Auxiliary Equipment Voltages

17.22.1 AC Voltage

The AC power supply will be as checked (✓) below:

120/240 VAC, three-wire

208 VAC, single-phase

___ VAC, single-phase

___ VAC, three-phase

17.22.2 DC Voltage

The DC power supply will be as checked (✓) below:

48 VDC

125 VDC

17.23 Oil-Level Protection

If checked (✓), each oil level indicator shall be furnished with two contacts as specified in Section 9.3.1 of this document, and backup oil level detector(s) shall be furnished as specified in Section 9.3.2 of this document

17.24 Main Tank Rapid-Pressure-Rise Relay

One rapid-pressure-rise relay, or provisions for such relay, shall be furnished on the main transformer tank as checked (✓) below (see Section 9.5 of this document):

One rapid-pressure-rise relay shall be furnished

Provisions shall be furnished for one future rapid-pressure-rise relay



Substation Equipment— Power Transformer, All Ratings

MATERIAL SPECIFICATION Substations and High- Voltage Equipment

© 2007 by PacifiCorp. All rights reserved.

Engineer (M. Weisensee): *MGW*
Standards Manager (G. Lyons): *GL*

ZS 001

Page 66 of 70

31 Oct 07

17.25 Alarm Monitor

If checked (✓), the transformer shall be furnished with the alarm monitor specified (see Section 9.7 of this document):

Rochester Instrument Systems AN6100B, 12 pt, 48VDC; Part number B2HX1WINTS12W24WMN/OF48C12FODC1FPLPCPPL

Rochester Instrument Systems AN6100B, 12 pt, 125VDC; Part number B2HX1WINTS12W24WMN/OF125C12FODC2FPLPCPPL

17.26 Core Ground

The core ground shall be as checked (✓) below (see Section 8.9 of this document).

External

Internal

17.27 Oil Preservation System

The type of oil preservation system shall be as checked (✓) below (see Section 8.11 of this document).

Sealed-tank system

Nitrogen-gas pressure system

Conservator system

Nitrogen-gas pressure or conservator system (supplier's choice)

17.28 Additional Test Requirements

In addition to the tests required by industry standards and the special requirements specified in Section 12 of this document, optional tests shall be performed as checked (✓) below in Table 16 (Class I transformer) or Table 17 (Class II transformer). Note that temperature test data from an identical or thermal duplicate transformer is *not* an acceptable alternative to specified temperature tests.

Table 16 - Optional Tests for Class I Transformer

(✓)	Optional Test Description
<input type="checkbox"/>	Temperature tests, including self-cooled temperature test and maximum forced-cooled temperature test
<input type="checkbox"/>	Lightning impulse tests
<input type="checkbox"/>	Quality control lightning impulse tests
<input type="checkbox"/>	Partial discharge measurements during 7200-cycle induced voltage tests
<input type="checkbox"/>	Combined 7200-cycle/one-hour induced voltage test with partial discharge measurements
<input type="checkbox"/>	Audible sound level tests including an octave band test

**MATERIAL SPECIFICATION
Substations and High-Voltage Equipment**

© 2007 by PacifiCorp. All rights reserved.

Engineer (M. Weisensee): *MW*
Standards Manager (G. Lyons): *GL*

**Substation Equipment—
Power Transformer, All
Ratings**



31 Oct 07

ZS 001
Page 67 of 70

ZS 001

Table 17 – Optional Tests for Class II Transformer

<input checked="" type="checkbox"/>	Optional Test Description
<input type="checkbox"/>	Temperature tests, including self-cooled temperature test and maximum forced-cooled temperature test
<input type="checkbox"/>	Switching impulse tests
<input type="checkbox"/>	Audible sound level tests including an octave band test

17.29 Audible Sound Level

The transformer shall be designed to comply with the decibel rating as checked () below.

- 10 dB relative to NEMA TR1
- NEMA TR1

17.30 Core-Form Clamping System Tightness

The complete core-and-coil assembly shall be dried and oil impregnated as a unit prior to final clamping of the windings. After final clamping, and before the core-and-coil assembly is placed inside the tank and released for testing, the tightness of the windings must be checked by a PacifiCorp representative (the tester), using PacifiCorp's hammer test. The transformer will not be accepted if any winding does not successfully withstand the hammer test.

The tightness of the blocks shall be checked using an 8-ounce hammer. For blocks on the outside of the winding, the tester shall tap directly on the blocks with the hammer. For blocks internal to the winding, the tester shall place a hardwood dowel against the blocks and tap the end of the dowel with the hammer. The tester shall be allowed to swing the hammer a distance of 15" from the block or dowel. The blocks shall not move when tapped. The tester shall watch for visible block movement, and shall also listen to the sound when the blocks are tapped: a sharp or high-pitched sound indicates a tight fit, while a dull or lower-pitched sound indicates a loose fitting block. Blocks shall be secured in place by means of pressure; blocks glued on both sides of the pressure points are not acceptable.

The tightness of the key spacers shall be checked using a 4-ounce hammer or mallet. The tester shall lightly tap directly on the spacers with the hammer or mallet while feeling for any movement on the other side of the spacer. The spacers shall not move when tapped. The tester shall exercise great care to insure that the test does not damage the windings.

17.31 Ladder

If checked (), a ladder shall be furnished as specified in Section 8.19 of this document

17.32 Safety Railing Equipment

If checked (), safety railing equipment shall be furnished as specified in Section 8.20 of this document



Substation Equipment— Power Transformer, All Ratings

MATERIAL SPECIFICATION Substations and High- Voltage Equipment

© 2007 by PacifiCorp. All rights reserved.

Engineer (M. Weisensee): *MGW*
Standards Manager (G. Lyons): *GL*

17.33 Winding Connections for Shipment

The transformer shall be shipped with the windings connected as follows:

17.34 Tank Contents for Shipment

The transformer tank shall be filled for shipment as checked (✓) below (see Section 14.1 of this document).

- Oil and dry nitrogen
- Dry air

18 Issuing Department

The Standards Engineering Documentation Department of PacifiCorp is responsible for issuing this material specification. Comments and suggestions are welcome. Submit comments or requests for additional copies of this document to:

PacifiCorp Standards Engineering Documentation
825 NE Multnomah St., Suite 1600, Portland, OR 97232
telephone: (503) 813-5293, fax: (503) 813-6804

Technical questions regarding this material specification may be submitted to:

Staff Engineers, PacifiCorp Standards Engineering
825 NE Multnomah St., Suite 1600, Portland, OR 97232
telephone: (503) 813-6883, fax: (503) 813-6804

**MATERIAL SPECIFICATION
Substations and High-
Voltage Equipment**

© 2007 by PacifiCorp. All rights reserved.

Engineer (M. Weisensee): *MW*
Standards Manager (G. Lyons): *GL*

**Substation Equipment—
Power Transformer, All
Ratings**



31 Oct 07

ZS 001
Page 69 of 70

ZS 001

This page is left blank intentionally.



ZS 001

Page 70 of 70

31 Oct 07

**Substation Equipment—
Power Transformer, All
Ratings**

**MATERIAL SPECIFICATION
Substations and High-
Voltage Equipment**

© 2007 by PacifiCorp. All rights reserved.

Engineer (M. Weisensee):

Standards Manager (G. Lyons):

MGW
GL

APPENDIX G
GEOTECHNICAL REPORT

APPENDIX H

LARGE GENERATION INTERCONNECTION AGREEMENT (LGIA)

APPENDIX I

MAKE-UP WATER ANALYSIS

APPENDIX J
FUEL ANALYSIS

APPENDIX K

DATA TO BE SUBMITTED WITH BID

SECTION 18049 - GAS TURBINE DATA TO BE SUBMITTED WITH BID

PART 1 - GENERAL

1.01 PERFORMANCE GUARANTEES:

The Contractor guarantees the performance of the equipment furnished to be at least as stated below when operated under the conditions specified. If (steam) (water) injection is required for NO_x control, the guarantees shall include the effect of the (water) (steam) injection.

A. Unit Performance Guarantees:

1. Unit Operating Conditions:

Gas Turbine Inlet:	Wet Bulb	_____°F
	Dry Bulb	_____°F
Bus Voltage:		_____ volts
System Power Factor:		90%
Evaporative Cooler Operating:		(Yes) (No)
Fuel:		Natural Gas

a. Base net output rating of turbine-generator, kW _____

- (1) Fuel Input, MMBtu/Hr (HHV) (LHV) _____
- (2) Exhaust gas flow, lbs/hr _____
- (3) Exhaust gas temperature, °F _____
- (4) Exhaust gas specific heat, Btu/lb/°F _____
- (5) Analysis of turbine exhaust gas, % vol.
 - (a) CO₂ _____
 - (b) N₂ _____
 - (c) H₂O _____
 - (d) O₂ _____
 - (e) VOC _____
 - (f) Particulate _____
- (6) (Steam) (Water) injection lb/hr _____

b. Peak net output rating of _____

- (1) Fuel Input, MMBtu/Hr (HHV) (LHV) _____
Turbine-generator, kW _____
- (2) Exhaust gas flow, lbs/hr _____

SECTION 18049 - GAS TURBINE DATA TO BE SUBMITTED WITH BID: continued

- (3) Exhaust gas temperature, °F _____
- (4) Exhaust gas specific heat, Btu/lb/°F _____
- (5) Analysis of turbine exhaust gas, % vol.
 - (a) CO₂ _____
 - (b) N₂ _____
 - (c) H₂O _____
 - (d) O₂ _____
 - (e) VOC _____
 - (f) Particulate _____
- (6) (Steam) (Water) injection lb/hr _____
- c. The net heat rate including all losses and auxiliary power uses will not exceed Btu/kWh (based on (HHV) (LHV) of fuel and net power to step-up transformer
 - (1) Peak load
 - Heat Rate, Btu/kWhr _____
 - Load, kW _____
 - (2) Baseload
 - Heat Rate, Btu/kWhr _____
 - Load, kW _____
 - (3) 3/4 load
 - Heat Rate, Btu/kWhr _____
 - Load, kW _____
 - (4) 1/2 load
 - Heat Rate, Btu/kWhr _____
 - Load, kW _____
- d. The spinning reserve net heat input will not exceed the following:
 - Heat input, Btu/hr (HHV) (LHV) _____
 - At minimum stable operating load of, kW _____
- e. The maximum generator capability at _____ volts, 90% power factor, when temp. rises are in accordance with ANSI standard C50 will be, kW: _____

SECTION 18049 - GAS TURBINE DATA TO BE SUBMITTED WITH BID: continued

- f. NO_x Emissions Control System:
 - (Steam pressure/temperature) _____/_____
 - (Minimum quality of water required) _____
 - Flow required at peak output, lb/hr _____
 - Flow required at base output, lb/hr _____
 - Flow required at 1/2 of baseload, lb/hr _____
- g. Exhaust Emissions (Corrected to 15% Oxygen):
 - At Peak Rating:
 - CO, ppm by volume _____
 - NO_x, ppm by volume _____
 - SO₂, ppm by volume _____
 - VOC, ppm by volume _____
 - Particulate, ppm by volume _____
 - At Base Rating:
 - CO, ppm by volume _____
 - NO_x, ppm by volume _____
 - SO₂, ppm by volume _____
 - VOC, ppm by volume _____
 - Particulate, ppm by volume _____
- h. Evaporative cooler water requirements:
 - Flow required at peak output, gpm _____
 - Flow required at base output, gpm _____
 - Flow required at 1/2 of base output, gpm _____
 - Minimum water quality required pH _____ to _____
 - Alkalinity, ppm max _____
 - Hardness, ppm max _____

B. Other Guarantees:

- 1. Silencing: When operating at baseload service rating, the sound pressure level is decibels to the reference level of 0.0002-microbar at all ground-level locations 3 feet from the unit will not exceed the following (based on 80°F, background noise 10 dB lower all octaves):

Octave Band

SECTION 18049 - GAS TURBINE DATA TO BE SUBMITTED WITH BID: continued

<u>No.</u>	
1	_____
2	_____
3	_____
4	_____
5	_____
6	_____
7	_____
8	_____
"A" Level	_____

The above values are maximum values and the orientation of maximum sound pressure level is _____.

2. Silencing: When operating at baseload service rating, the sound pressure level is decibels to the reference level of 0.0002-microbar at all ground-level locations 10 feet from the air inlet filter will not exceed the following (based on 80°F, below 5 mph wind, and background noise 10 dB lower all octaves):

Octave Band	
<u>No.</u>	
1	_____
2	_____
3	_____
4	_____
5	_____
6	_____
7	_____
8	_____
"A" Level	_____

SECTION 18049 - GAS TURBINE DATA TO BE SUBMITTED WITH BID: continued

The above values are maximum values and the orientation of maximum sound pressure level is _____

1.02 EXPECTED UNIT PERFORMANCE:

The Contractor shall submit with the Bid the following expected performance data by filling in the blanks provided:

A. Unit Performance Guarantees:

1. Unit Operating Conditions:

Gas Turbine Inlet: Wet Bulb _____ °F
Dry Bulb _____ °F
Bus Voltage: _____ volts
System Power Factor: 90%
Evaporative Cooler Operating: (Yes) (No)
Fuel: Natural Gas

- a. Base net output rating of turbine-generator, kW _____
- (1) Fuel Input, MMBtu/Hr (HHV) (LHV) _____
 - (2) Exhaust gas flow, lbs/hr _____
 - (3) Exhaust gas temperature, °F _____
 - (4) Exhaust gas specific heat, Btu/lb/°F _____
 - (5) Analysis of turbine exhaust gas, % vol.
 - (a) CO₂ _____
 - (b) N₂ _____
 - (c) H₂O _____
 - (d) O₂ _____
 - (6) (Steam) (Water) injection lb/hr _____
- b. Peak net output rating of _____
- (1) Fuel Input, MMBtu/Hr (HHV) (LHV) _____
Turbine-generator, kW _____
 - (2) Exhaust gas flow, lbs/hr _____

SECTION 18049 - GAS TURBINE DATA TO BE SUBMITTED WITH BID: continued

- (3) Exhaust gas temperature, °F _____
- (4) Exhaust gas specific heat, Btu/lb/°F _____
- (5) Analysis of turbine exhaust gas, % vol.
 - (a) CO₂ _____
 - (b) N₂ _____
 - (c) H₂O _____
 - (d) O₂ _____
- (6) (Steam) (Water) injection lb/hr _____
- c. The net heat rate including all losses and auxiliary power uses will not exceed Btu/kWh (based on (HHV) (LHV) of fuel and net power to step-up transformer
 - (1) Peak load
 - Heat Rate, Btu/kWhr _____
 - Load, kW _____
 - (2) Baseload
 - Heat Rate, Btu/kWhr _____
 - Load, kW _____
 - (3) 3/4 load
 - Heat Rate, Btu/kWhr _____
 - Load, kW _____
 - (4) 1/2 load
 - Heat Rate, Btu/kWhr _____
 - Load, kW _____
- d. The spinning reserve net heat input will not exceed the following:
 - Heat input, Btu/hr (HHV) (LHV) _____
 - At minimum stable operating load of, kW _____
- e. The maximum generator capability at _____ volts, 90% power factor, when temp. rises are in accordance with ANSI standard C50 will be, kW: _____
- f. NO_x Emissions Control System: _____
 - (Steam pressure/temperature) _____ / _____

SECTION 18049 - GAS TURBINE DATA TO BE SUBMITTED WITH BID: continued

(Minimum quality of water required) _____
Flow required at peak output, lb/hr _____
Flow required at base output, lb/hr _____
Flow required at 1/2 of baseload, lb/hr _____

g. Exhaust Emissions:

At Peak Rating:

CO, ppm by volume _____
NO_x, ppm by volume _____
SO₂, ppm by volume _____
based on ___% sulfur by weight in fuel _____

At Base Rating:

CO, ppm by volume _____
NO_x, ppm by volume _____
SO₂, ppm by volume _____
based on ___% sulfur by weight in fuel _____

h. Evaporative cooler water requirements:

Flow required at peak output, gpm _____
Flow required at base output, gpm _____
Flow required at 1/2 of base output, gpm _____
Minimum water quality required pH _____ to _____
Alkalinity, ppm max _____
Hardness, ppm max _____

2. Turbine Parts Life: Anticipated hours of operation at base rating before maintenance inspections are required based on ___ starts per year.

Combustion inspection, hrs _____
Hot gas inspection, hrs _____
Major inspection, hrs _____

3. Turbine Maintenance: Anticipated maintenance requirements at base rating based upon ___ starts per year.

a. Anticipated number of maintenance man-hours required for:

SECTION 18049 - GAS TURBINE DATA TO BE SUBMITTED WITH BID: continued

- Combustion inspection, man-hours _____
 - Hot gas inspection, man-hours _____
 - Major inspection, man-hours _____
- b. Anticipated average number of maintenance man-hours expended per year, man-hrs _____
- 4. Firing Temperatures:
 - Firing temp. at peak rating, F _____
 - Firing temp. at base rating, F _____
 - Firing temp. quoted above is measured at (location on turbine) _____
- 5. Pressure Losses: The following pressure drops are in inches of water based on standard air with the unit operating under:
 - a. "Peak rating" conditions:
 - Total pressure loss to inlet flange at package, In. H₂O _____
 - Total pressure loss from turbine exhaust flange, In. H₂O _____
 - b. "Base rating" conditions:
 - Total pressure loss to inlet flange at package, In. H₂O _____
 - Total pressure loss from turbine exhaust flange, In. H₂O _____
- 6. Standby Requirements:
 - Standby energy consumption per hour ____°F, kW-hr _____
 - Max. standby ac power demand, kW _____
 - Max. demand on battery, amps ____ volts _____
- 7. Start-Up Time: Normal start/normal load
 - Cold standstill to ready for synchronizing, minutes _____
 - Synchronizing to baseload, minutes _____
 - Cooling air requirements, cfm
 - Base load _____
 - Peak load _____
 - Period of time cooling air is required after trip, minutes _____

1.03 DESCRIPTION OF EQUIPMENT:

SECTION 18049 - GAS TURBINE DATA TO BE SUBMITTED WITH BID: continued

The Contractor shall furnish equipment in accordance with the Specifications, and guarantees the performance of the following equipment to meet the requirements specified. The Contractor shall submit with the Bid the following equipment data:

A. Equipment Data:

1. Prime Mover and Power Train:

Combustion turbine, Mfgr. and type _____

Power turbine, Mfgr. and type _____

Type of burners _____

Gas turbine speed, rpm _____

Power turbine speed, rpm _____

Reduction gear manufacturer _____

Reduction gear capacity at 100,000-hr service rating, kW _____

Speed regulation full load to no load under
normal conditions, percent _____

Increase in speed over full-load speed with full load
suddenly thrown off, percent _____

2. Generator: (Data based __ F cooling water and __ ft. MSL,
excepted as otherwise noted)

Manufacturer and type _____

Rated voltage, volts _____

Speed, rpm _____

Short-circuit ratio _____

Rated kVA and basis of rating _____

Exciter type _____

Field voltage - no load _____

Field voltage - peak capacity, 0.9-pf _____

Field current - peak capacity, 0.9-pf amps _____

Max. total temp. w/_ F ambient at:

Base Capacity/and Peak Capacity, Kva _____/_____

Rotor, degrees C (by resistance) _____/_____

Stator, degrees C (by detector) _____/_____

Calculated telephone interference factor,

SECTION 18049 - GAS TURBINE DATA TO BE SUBMITTED WITH BID: continued

- TIF of generator:
 - Balanced: _____
 - Residual: _____
- Lowest cooling air temp. permitted at windings during operation, F _____
- Percent reactance on the peak kVA base and at rated voltage of __ kV:
 - Direct axis synchronous at rated current, X_d _____
 - Transient unsaturated at rated current, X'_{du} _____
 - Transient saturated, X'_d _____
 - Subtransient (at rated voltage) X''_d _____
 - Zero sequence (at rated voltage) X_0 _____
 - Negative sequence (at rated voltage) X_2 _____
 - Synchronous impedance, Z_d _____
 - Three-phase capacitance to ground, mfd _____
- 3. Metal-Clad Switchgear:
 - Manufacturer of switchgear structure _____
 - Manufacturer and type of circuit breakers _____
 - Manufacturer and type of switchgear relays _____
- 4. Generator Accessory Equipment:
 - Manufacturer and type of arresters _____
 - Manufacturer and type of capacitors _____
 - Manufacturer and type of main breaker _____
 - Manufacturer of neutral transformer and resistor _____
 - Telephone influence factor suppression accessories, if required to meet specified TIF; description _____
- 5. Auxiliary Power Apparatus:
 - Manufacturer and type of motor starters _____
 - Manufacturer of transformers _____
 - Station auxiliary transformer kVA/volt rating _____/_____
 - Starting motor transformer kVA/volt rating _____/_____
- 6. Silencing Equipment:
 - Manufacturer _____

SECTION 18049 - GAS TURBINE DATA TO BE SUBMITTED WITH BID: continued

Inlet, ft in length _____
Exhaust, ft in length _____
Other, describe _____

7. Exhaust Connection Dimensions _____

8. Intake Evaporative Air Cooler
Manufacturer _____
Face area _____

9. Inlet Air Filter:
Number of stages _____
Pressure drop across filters _____
Face area _____

10. Generator Air Filter:
Manufacturer and Model Number _____
Face area _____

11. Starting System:
Type _____
Manufacturer _____
Horsepower and Voltage _____

12. Lubricating Oil and Special Fluids:
Type and quantity for combustion turbine _____
Type and quantity for power turbine _____
Type and quantity for generator _____
Special fluids required, list _____

13. Other:
Ac standby power connected load, kW _____
Dc standby power connected load, kW _____
Describe other major equipment _____

14. Major Component Weights: (in pounds)

SECTION 18049 - GAS TURBINE DATA TO BE SUBMITTED WITH BID: continued

Combustion Turbine Unit	_____
Power Turbine Unit	_____
Generator and Exciter	_____
Other Major Equipment	_____
Describe _____	_____
_____	_____
_____	_____
Heaviest piece to be handled during erection (identify piece)	_____
Heaviest piece to be handled after erection (identify piece)	_____
Heaviest piece to be handled for routine inspection of	
hot gas path	_____
Compressor rotor	_____
Power turbine rotor	_____
Generator rotor	_____

PART 2 - PRODUCTS - Not Applicable.

PART 3 - EXECUTION - Not Applicable.

END OF SECTION 18049

SECTION 18099 - HRSG DATA TO BE SUBMITTED WITH BID

PART 1 - GENERAL

1.01 PERFORMANCE GUARANTEES:

A. The Contractor guarantees the performance of the heat recovery steam generator to be as stated below when the unit is operated using combustion turbine exhaust under the conditions specified in SECTION 2.

- 1. Outlet steam flow, lb/hr _____
- 2. Superheater outlet pressure, psig _____
- 3. Superheater outlet temperature, °F _____
- 4. Steam Purity:
 - a. Maximum total solids in steam entering superheater, ppm _____
 - b. Maximum silica in steam entering superheater, ppm _____
- 5. Duct burner nitrogen oxides production, lbs/MMBtu _____
- 6. Duct burner carbon monoxides production, lbs/MMBtu _____
- 7. Duct burner particulate production, lbs/MMBtu _____
- 8. Duct burner VOC production, lbs/MMBtu _____
- 9. Maximum combustion turbine backpressure, inch WG _____
- 10. Stack exit gas temperature, °F _____
- 11. Feedwater inlet pressure required, psig _____
- 12. Supplemental firing fuel, MMBtu/hr _____
- 13. Fan power usage, kW _____

B. The Contractor guarantees the performance of the heat recovery steam generator to be as stated below when the unit is operated with fresh air firing under the conditions specified in SECTION 2.

- 1. Outlet steam flow, lb/hr _____
- 2. Steam outlet pressure, psig _____
- 3. Superheater outlet temperature, °F _____
- 4. Steam Purity:
 - a. Maximum total solids in steam entering superheater, ppm _____

SECTION 18099 - HRSG DATA TO BE SUBMITTED WITH BID: continued

- b. Maximum silica in steam entering superheater, ppm _____
- 5. Gas side pressure drop, inch WG _____
- 6. Maximum nitrogen oxides emissions, lbs/MMBtu _____
- 7. Maximum carbon monoxides emissions, lbs/MMBtu _____
- 8. Maximum particulate emissions, ppm _____
- 9. Maximum VOC emissions, lbs/MMBtu _____
- 10. Stack exit gas temperature, °F _____
- 11. Feedwater inlet pressure required, psig _____
- 12. Supplemental firing fuel, MMBtu/hr _____
- 13. Fan power usage, kW _____
- 14. Time to regain full steam load after combustion turbine trip, seconds _____

1.02 EXPECTED PERFORMANCE DATA:

- A. The Contractor shall submit the following expected performance data by filling in the blanks provided:

<u>Operating Mode</u>	<u>CT Exhaust w/o Supp. Fire</u>	<u>CT Exhaust w/Supp. Fire</u>	<u>Fresh Air Max. Load</u>	<u>Fresh Air 80% Load</u>
Steam Flow at Superheater Outlet thousand lbs/hr				
Superheater Outlet Pressure, psig				
1. Quantities				
a. Combustion air flow, lb/hr	_____	_____	_____	_____
b. Supplemental firing fuel, lb/hr	_____	_____	_____	_____
2. Pressure Drops				
a. Drum to superheater outlet, psi	_____	_____	_____	_____

SECTION 18099 - HRSG DATA TO BE SUBMITTED WITH BID: continued

b.	Economizer inlet to drum, psi	_____	_____	_____	_____
3.	Temperatures, °F				
a.	Superheater outlet steam	_____	_____	_____	_____
b.	Steam after desuperheater	_____	_____	_____	_____
c.	Steam before desuperheater	_____	_____	_____	_____
d.	Drum outlet steam				
e.	Economizer outlet water	_____	_____	_____	_____
f.	Air/Flue Gas	_____	_____	_____	_____
(1)	Entering duct burner	_____	_____	_____	_____
(2)	Leaving duct burner	_____	_____	_____	_____
(3)	Entering superheater	_____	_____	_____	_____
(4)	Entering boiler	_____	_____	_____	_____
(5)	Entering economizer	_____	_____	_____	_____
(6)	Entering ID fan	_____	_____	_____	_____
(7)	Entering stack	_____	_____	_____	_____
4.	Air/Flue Gas Resistance, In WG	_____	_____	_____	_____
a.	Inlet damper	_____	_____	_____	_____
b.	Transition duct	_____	_____	_____	_____
c.	Duct burner	_____	_____	_____	_____
d.	Superheater	_____	_____	_____	_____
e.	Boiler	_____	_____	_____	_____
f.	Economizer	_____	_____	_____	_____
g.	Ductwork, economizer to fan	_____	_____	_____	_____

SECTION 18099 - HRSG DATA TO BE SUBMITTED WITH BID: continued

h.	Ductwork, fan to stack	_____	_____	_____	_____
i.	Other	_____	_____	_____	_____
j.	Combustion turbine Backpressure	_____	_____	_____	_____
k.	Total or Delta on Fan	_____	_____	_____	_____
5.	Fan Test Block Data	Design Point	Test Block		
a.	Inlet temp, °F	_____	_____		
b.	Inlet flow, lb/hr	_____	_____		
c.	Inlet flow, cfm	_____	_____		
d.	Static pressure, in WG	_____	_____		
e.	Fan speed, rpm	_____	_____		
f.	BHP	_____	_____		

1.03 DESCRIPTION OF EQUIPMENT:

The Contractor shall submit with the Bid the following equipment data:

- A. Model designation: _____
- B. Design Pressures:
 - 1. Superheater, psi _____
 - 2. Drum, psi _____
 - 3. Boiler, psi _____
 - 4. Economizer, psi _____
 - 5. Ductwork and Casing,
In WG (Vacuum/Pressure) _____/_____
- C. Total Effective Heating Surface, Sq. Ft.
 - 1. Superheater _____
 - 2. Boiler _____
 - 3. Economizer _____
- D. Size and Material of Tubes:
 - 1. Superheater _____
 - 2. Boiler _____

SECTION 18099 - HRSG DATA TO BE SUBMITTED WITH BID: continued

- 3. Economizer _____
- E. Description and Material of Fins:
 - 1. Superheater _____
 - 2. Boiler _____
 - 3. Economizer _____
- F. Casing and Ductwork:
 - 1. Casing material _____
 - 2. Thickness _____
 - 3. Duct material _____
 - 4. Thickness _____
- G. Duct Burner:
 - 1. Manufacturer _____
 - 2. Type or model _____
 - 3. Maximum Capacity, MMBtu/hr _____
- H. Weights, Lbs:
 - 1. Steam generator _____
 - 2. Platforms, stairs, support steel _____
 - 3. Total weight of complete unit _____
 - a. Dry _____
 - b. During normal operation _____
 - c. During hydrostatic test _____
- I. Steam Drum:
 - 1. Length _____
 - 2. Diameter _____
 - 3. Thickness _____
 - 4. Material _____
- J. Connection Sizes:
 - 1. Feedwater inlet, inches _____
 - 2. Steam outlet, inches _____
- K. Safety Valves:
 - 1. Number _____
 - 2. Model _____
 - 3. Size _____

SECTION 18099 - HRSG DATA TO BE SUBMITTED WITH BID: continued

L. Stack Dimensions:

1. Diameter _____
2. Height _____
3. Material _____
4. Thickness _____

M. In addition to the data requested above, the Contractor shall submit the following:

1. General arrangement drawing showing duct and equipment layout. Also to be included are maximum loads and locations of duct supports, if required.
2. Preliminary foundation outline and loads of all items.
3. List of all instrumentation and boiler trim, including number of items, size, manufacturer, and model number.
4. Preliminary control panel outline drawing and panel front arrangement drawing.
5. Information concerning special requirements for curing of refractory and insulation which impact turbine operation (i.e., temperature limits and times).
6. Description of type of fins (segmented or continuous, etc).
7. List of previously completed projects.

PART 2 - PRODUCTS - NOT APPLICABLE

PART 3 - EXECUTION - NOT APPLICABLE

END OF SECTION 18099

SECTION 18149 - DATA TO BE SUBMITTED WITH BID - STEAM TURBINE

PART 1 - GENERAL

1.01 PERFORMANCE GUARANTEES:

A. The Contractor guarantees the characteristics of the turbine generator unit to be at least as stated below when operated under the conditions specified.

1. Guaranteed capability at rated throttle and reheat conditions with _____-inch mercury absolute backpressure, zero percent makeup, full feedwater heating, rated hydrogen pressure and 0.9 power factor: _____ kW.
2. Guaranteed throttle flow at rated throttle and reheat conditions with _____ -inch mercury absolute backpressure, 0% makeup, full feedwater heating, rated hydrogen pressure, and 0.9 power factor _____ lb/hr.
3. Turbine (gross) (net) heat rates at rated throttle and reheat conditions with _____-inch mercury absolute backpressure, 0% makeup, full feedwater heating, rated hydrogen pressure, and 0.9 power factor:

<u>Percent of Guaranteed Capability</u>	<u>Turbine (Gross)(Net) Heat Rate, Btu/kWh</u>
100	_____
80	_____
60	_____
40	_____
20	_____

4. Generator capability at 0.9 power factor:

<u>Hydrogen Pressure</u>	<u>Generator Capability,</u>
Full psig	_____
Intermediate psig	_____
Minimum psig	_____

5. Output voltage: _____ volts.
6. Generator efficiency at rated load: _____%.

SECTION 18149 - DATA TO BE SUBMITTED WITH BID - STEAM TURBINE: continued

7. Temperature rise of the following:
 - a. Generator Stator: _____ °C.
 - b. Generator Rotor: _____ °C.
 - c. Generator Exciter - Stator: _____ °C.
- Rotor: _____ °C.
8. Maximum hydrogen loss at full frame pressure and at rated kVA operation: _____ standard ft³/day.
9. Full frame hydrogen pressure: _____ psig.

1.02 EXPECTED PERFORMANCE DATA:

- A. The Contractor shall submit the following expected performance data by filling in the blanks provided:
 1. Maximum expected throttle flow, capability and heat rate when operating at valves wide open, 5% overpressure, 1000°F High Pressure, 1000°F Hot Reheat, _____-inch mercury absolute backpressure, zero percent makeup, full feedwater heating, rated hydrogen pressure, and 0.9 power factor:
 - a. Throttle flow: _____ lb/hr
 - b. Capability: _____ kW
 - c. (Gross) (Net) heat rate: _____ Btu/kWh
 - d. Reheat steam flow: _____ lb/hr
 - e. Condenser steam flow: _____ lb/hr
 2. Maximum expected throttle flow, capability and heat rate when operating at valves wide open, rated pressure, 1000°F High Pressure, 1000°F Hot Reheat, _____-inch mercury absolute backpressure, 0% makeup, full feedwater heating, rated hydrogen pressure, and 0.9 power factor:
 - a. Throttle flow: _____ lb/hr
 - b. Capability: _____ kW
 - c. Reheat steam flow: _____ lb/hr
 - d. Condenser steam flow: _____ lb/hr
 3. Minimum safe continuous load
 - a. at _____ inch Hg absolute: _____ kW
 4. Minimum absolute backpressure
for safe continuous operation of the unit:

SECTION 18149 - DATA TO BE SUBMITTED WITH BID - STEAM TURBINE: continued

- a. At full load: _____ in. Hg
- b. At minimum continuous load: _____ in. Hg
- 5. Minimum time required for applying full load on the unit:
 - a. After 8-hour shutdown on turning gear _____ minutes
 - b. From cold start _____ minutes
- 6. Maximum allowable exhaust hood temperature:
 - a. During start-up: _____ °F for _____ minutes. _____ °F.
 - b. During continuous operation _____ °F.
- 7. No load throttle flow at rated conditions and _____-inch mercury absolute backpressure: _____ lb/hr
- 8. Generator efficiency with full frame hydrogen pressure:
 - Maximum expected load _____ %
 - Guaranteed load _____ %
 - a. 80% guaranteed load _____ %
 - b. 60% guaranteed load _____ %
 - c. 40% guaranteed load _____ %
 - d. 20% guaranteed load _____ %
- 9. Generator capability with one hydrogen cooler out of service: _____ kVA
- 10. Generator field current at rated load: _____ amps
- 11. Rated load field voltage: _____ volts
- 12. Excitation system ceiling voltage (per unit of rated field voltage) _____ p.u.
- 13. Excitation system voltage response time: _____ volts/sec
- 14. Percent reactances on a base of _____ kVA (to be maximum for generator) and at _____ kV

SECTION 18149 - DATA TO BE SUBMITTED WITH BID - STEAM TURBINE: continued

- a. Direct axis synchronous at rated current X_d _____
- b. Transient unsaturated at rated current X'_{du} _____
- c. Transient saturated, X'_d _____
- d. Subtransient (at rated voltage) X''_d _____
- e. Zero sequence (at rated current) X_0 _____
- f. Negative sequence (at rated voltage) X_2 _____
- g. Synchronous impedance, Z_d _____
- 15. Time constants:
 - a. Open circuit, T'_{do} _____
 - b. Armature, T_a _____
 - c. Transient, T_d _____
 - d. Subtransient, T''_d _____
- 16. Pull-out torque at rated voltage and kVA with infinite bus:
 - a. At 0.85 pf _____ kW
 - b. At 0.90 pf _____ kW
 - c. At 1.0 pf _____ kW
- 17. Winding capacitance, all three phases combined to ground: _____ mfd
- 18. Telephone interference factors, calculated:
 - a. Balanced: _____
 - b. Residual: _____
- 19. Short circuit ratio at rated kVA and maximum frame hydrogen pressure, calculated: _____
- 20. Flywheel effect, WR^2
 - a. For turbine: _____ in lb-ft²

SECTION 18149 - DATA TO BE SUBMITTED WITH BID - STEAM TURBINE: continued

- b. For generator and exciter: _____ in lb-ft²
- 21. Saturation factor: _____
- 22. Regulation at: _____ kVA
(to be maximum for generator)
- and 0.9 power factor: _____ %
- 23. Rated armature current: _____ amps
- 24. Field characteristics at 125°C:

	Amperes	Volts
a. Exciter rating:		
b. No load, at rated generator terminal voltage at 20°C		
c. Rated armature current, zero generator-terminal voltage		
d. With machine carrying rated kVA, with rated terminal voltage and 0.9 power factor, at:		
(1) Full frame hydrogen pressure:		
(2) Intermediate hydrogen pressure: _____ psig		
e. Minimum field current required to hold generator in step under steady state loading at guaranteed capability.		
f. Generator load and power factor with machine carrying rated kVA, with rated terminal voltage, full frame hydrogen pressure and with leading power factor (maximum pull out on infinite bus)		
	_____ kW	_____ pf
g. Field conductor material:		
h. Field resistance, ohms at 20°C:		
i. Field temperature coefficient of		

SECTION 18149 - DATA TO BE SUBMITTED WITH BID - STEAM TURBINE: continued

- resistance, ohms/ohm/°C _____
from 0°C: _____
- j. Field discharge resistor rating
at 20°C, ohms: _____
25. Gas volume within stator housing
with rotor in place: _____ ft³
26. Hydrogen temperature at full rated
kVA, 0.90 power factor, and
95°F inlet cooling water:
- a. Entering Hydrogen Cooler
(hot Hydrogen) _____ °C
- b. Leaving Hydrogen Cooler
(cold Hydrogen) _____ °C

1.03 PHYSICAL DATA:

- A. Contractor shall submit his standard proposition outline drawing of the turbine generator unit which shall show at least the following information:
1. Weights of major components (including heaviest single lift required for placement and/or maintenance). .
 2. Dimensions (length, width, height) adequate for layout and preliminary foundation design including turbine room hook height required for service and maintenance.
 3. Number and size of Owner's connections.
 4. Excitation switchgear dimensions, if applicable.
 5. Neutral enclosure dimensions.
 6. Last stage blade length.
 7. Clearance diagram for generator rotor removal, straight and skewed.
 8. Clearance diagram for hydrogen cooler removal.

1.04 MISCELLANEOUS DATA:

- A. Contractor shall submit the following miscellaneous data by filling in the blanks provided:
1. Turning gear data:
 - a. Speed of rotor: _____ rpm
 - b. Motor size: _____ hp

SECTION 18149 - DATA TO BE SUBMITTED WITH BID - STEAM TURBINE: continued

2. Cooler data with cooling water inlet temperature listed:

a. Cooling water flow expected:

- (1) Lube oil coolers (____°F) _____ gpm
- (2) Electrohydraulic system
coolers (____°F) _____ gpm
- (3) Gland steam condenser
(min ____°F) _____ gpm
- (4) Hydrogen coolers
(____°F) _____ gpm
- (5) Seal oil coolers
(____°F) _____ gpm
- (6) Exciter coolers (____°F) _____ gpm
- (7) Conductor cooling system
coolers (____°F) _____ gpm

b. Cooling water pressure drop
expected:

- (1) Lube oil coolers _____ psi
- (2) Electrohydraulic system
coolers _____ psi
- (3) Gland steam condenser _____ psi
- (4) Hydrogen coolers _____ psi
- (5) Seal oil coolers _____ psi
- (6) Exciter coolers _____ psi
- (7) Conductor cooling system
coolers _____ psi

c. Tube Diameter (I.D.)

- (1) Lube oil coolers _____ in
- (2) Electrohydraulic system
coolers _____ in
- (3) Gland steam condenser _____ in
- (4) Hydrogen coolers _____
- (5) Seal oil coolers _____ in
- (6) Exciter coolers _____ in

SECTION 18149 - DATA TO BE SUBMITTED WITH BID - STEAM TURBINE: continued

- (7) Conductor cooling system
coolers _____ in
3. Gland steam flow:
a. Maximum _____ lb/hr
b. Minimum _____ lb/hr
Exhaust annulus area: _____ sq ft
4. Lubricating oil circulation rate
through coolers: _____ gpm
5. Total volume of lube oil required: _____ gal
6. Total volume of governor fluid required: _____ gal

PART 2 - PRODUCTS - Not Applicable.

PART 3 - EXECUTION - Not Applicable.

END OF SECTION 18149

APPENDIX L

**PACIFICORP – “6B.5 – Fence Application and Construction,
dated September 2007”**

6B.5—Fence Application and Construction

Standards Engineering Documentation

Date: 10 Sept 07

© 2007 by PacifiCorp. All rights reserved.

Contents

SECTION	PAGE
1 Scope	1
2 References	1
3 General	1
3.1 Compliance with NESC	2
3.2 Grounding Requirements	2
3.3 Locked Entrance	2
3.4 Isolation of Fences	2
3.5 Clearances from Structures	2
3.6 Curbing at Fence Line	2
4 Fence Construction	3
4.1 Post Spacing Location and Selection	3
4.2 Fence and Barbed Wire Height	3
4.3 Excavation and Concrete Work	3
4.4 Extension Arms and Barbed Wire	3
4.5 Top Rail	4
4.6 Bracing	4
4.7 Tension Wire	4
4.8 Fabric	4
4.9 Gates	4
4.10 Warning Signs	5
4.11 Inward-Opening Gate	5
4.12 Cleanup	5
5 Fence Material Specifications	9
5.1 Fabric	9
5.2 Framework	9
5.3 Fittings	11
5.4 Pickets	12
6 Fence Isolation Sections	12
6.1 Existing Terminal Post	12
6.2 Insulation From the Isolation Section Of Fence	12
6.3 Terminal Post	12
6.4 Additional Information	12
7 Removable Fence Section	13

8	Curbed Fence Standards	14
9	Fence Safety Clearances	16
10	Fence Relocation	17
	10.1 Expansion of Substations	17
	10.2 New Fence to Existing Fence	18
11	Handbook Issuing Department	18

FIGURES	PAGE
Figure 1 - Inward Gate Swing	5
Figure 2 - Outward Gate Swing	5
Figure 3 - Standard Gate Construction	6
Figure 4 - Gate Catch Details	6
Figure 5 - Standard Fence Corner Construction	7
Figure 6 - Standard Fence and Gate Construction Details	8
Figure 7 - Insulated Fence Panel	13
Figure 8 - Removable Fence Section, 16-foot	14
Figure 9 - Curbed Fence Standard	15
Figure 10 - Safety Clearance for Substation Fence	17
Figure 11 - Joint Unequal Height Fence Section	18

TABLE	PAGE
Table 1 - Fencing Framework Sizes	10
Table 2 - Fence Safety Clearances (Dimensions for use with Figure 10)	16
Table 3 - Fence Operating Clearances (Dimensions for use with Figure 10)	16

TABLE

PAGE

This page is left blank intentionally.

6B.5—Fence Application and Construction

1 Scope

This standard covers the construction requirements for permanent fencing around PacifiCorp substations or substation equipment. This standard shall also be used as an attachment to construction contracts for fence installation. The design considerations covered by this fencing application and construction standard are as follows:

39. Fence safety clearances
40. Curbed fence installations
41. Fence isolation
42. Removable fence subsection
43. Fence relocation

2 References

ANSI/IEEE C2-1987, *National Electrical Safety Code*

ANSI/IEEE 1119-1988, *Guide for Fence Safety Clearances in Electric-Supply Stations*

ASTM A90-1981, *Standard Test Method for Weight of Coating on Zinc-Coated (Galvanized) Iron or Steel Articles (Reaff 1991)*

ASTM A121 E1-1986, *Standard Specification for Zinc-Coated (Galvanized) Steel Barbed Wire*

ASTM A392, Rev B-1991, *Standard Specifications for Zinc-Coated Steel Chain-Link Fence Fabric*

ASTM A446/A446M-1991, *Standard Specification for Steel Sheet, Zinc-Coated (Galvanized) by the Hot-Dip Process, Structural (Physical) Quality*

ASTM A569/A569M Rev A-1991, *Standard Specification for Steel, Carbon (0.15 Maximum, Percent), Hot-Rolled Sheet and Strip Commercial Quality*

ASTM A824-1991, *Standard Specification for Metallic-Coated Steel Marcellled Tension Wire for Use with Chain Link Fence*

ASTM F626-1990, *Standard Specification for Fence Fittings*

ASTM F669-1991, *Standard Specifications for Strength Requirements of Metal Post and Rails for Industrial Chain Link Fence*

ASTM F1083-1991, *Standard Specifications for Pipe, Steel, Hot-Dipped Zinc-Coated (Galvanized) Welded, for Fence Structures*

ASTM F1234 Rev A-1990, *Standard Specification for Protective Coatings on Steel Framework for Fences*

PacifiCorp Construction Standard SF 001, *Substation Grounding*

3 General

Fences are required to be installed around electrical equipment to minimize the possibility of entrance by unauthorized persons. This requirement includes platform mounted transformers and regulators which do not meet above ground equipment clearances.

3.1 Compliance with NESC

The construction of the fence must comply with NESC. This fencing standard is divided into the following subsections:

1. Fence Construction Standard
2. Fence Material Specifications
3. Fence Isolation Sections
4. Removable Fence Section
5. Curbed Fence Standards
6. Fence Safety Clearances
7. Fence Relocation

3.2 Grounding Requirements

Fences installed at electrical facilities typically must be grounded. All fencing shall be installed per 6B.6, Substation Grounding.

3.3 Locked Entrance

Entrances through fences not under observation of an authorized attendant shall be kept locked.

3.4 Isolation of Fences

PacifiCorp substation fences shall not be connected to any other fence. See subsection 6, *Fence Isolation Sections*, for additional information.

3.5 Clearances from Structures

The minimum distance that the fence should be installed from any substation structure supporting a live part shall be based on section 9 of this standard. Any objects inside or outside the substation should not be located within a restricted zone. The minimum restricted zone shall be ± 5 feet wide and 16 feet high; see Figure 10. If the minimum 5 feet distance cannot be met, measures should be taken to prevent the likelihood of a person using the object to gain access to the substation. The restricted zone outside the substation fence may be used for the planting of screening vegetation, as long as it is not climbable by a person.

3.6 Curbing at Fence Line

Curbing at the fence line should be installed around new substations that are being constructed in residential areas. The purpose of the curbed fences is to prevent entrance under substation fences. Curbing at the fence line can also be installed to provide oil containment in rural areas if cost effective (see subsection 8, *Curbed Fence Standards*).

4 Fence Construction

The fence shall be constructed of chain link and shall be installed in strict compliance with furnished plans and these standards. Installation shall use good workmanship by skilled craftsmen, experienced in erection of this type of fencing. The fence shall be erected on the lines and to the grade as provided by PacifiCorp. For more detail refer to Figure 3 through Figure 6 of this guideline.

4.1 Post Spacing Location and Selection

Posts shall be spaced not more than 10 feet on centers in the line of the fence (adjust to even spaces). They shall be plumb with tops properly graded and aligned. Corner posts shall be located at all angles of 20° or greater. Pull posts shall be placed not over 1500 feet apart in each line of fence or when a grade change of more than 20° (slope ratio of 10 to 3.5) occurs.

4.2 Fence and Barbed Wire Height

Fence shall stand eight feet above grade with a fabric height of 7 feet and 3 strands of barbed wire 1 foot high on brackets 45° outbound.

4.3 Excavation and Concrete Work

Curbs and all foundations for posts and gate catches shall be concrete with the top 6 inches formed. Minimum concrete dimensions appear on Figure 3 and Figure 5 of this standard.

4.3.1 Concrete Mix

Ready mix concrete shall have a minimum 28 day compressive strength of 3000 psi, maximum slump of 4 inches, air content of 4.5% to 7.5%, and water to cement ratio at time of placement of 5.3:10 by weight. Site mixed concrete shall be a 1:2:3 mix (1 cement, 2 sand, and 3 gravel). Maximum slump for site mixed concrete shall be 4 inches.

4.3.2 Finish

The top exposed surface of the concrete shall be crowned to shed water and troweled smooth. Top of concrete shall be formed in line with sides of hole to avoid "mush-rooming" of the concrete. Top of exposed surface of concrete shall be crowned 1 inch above subgrade.

4.3.3 Installation in Rocky Ground

Where solid rock is encountered, a hole 2 inches larger than the post diameter may be drilled and the post grouted into the hole with a fine mix of concrete. Minimum depth of holes in solid rock shall be 12 inches for line posts and 18 inches for end, corner, gate, and pull posts. Where solid rock is covered with an overburden of soil, the posts shall be set in the solid rock to the depth as listed above and the upper portion of the hole shall be completed as a standard concrete footing.

4.4 Extension Arms and Barbed Wire

All extension arms shall be firmly seated on the top of the posts with the blade portion of the arm slanting outward at 45°. Three strands of barbed wire shall be installed with sufficient

tension to maintain tautness during temperature changes and shall be securely fastened to extension arms.

4.5 Top Rail

The top rail shall pass through the base of the line post tops and shall be securely fastened to terminal posts. Every fifth coupling in sections 100 feet or longer shall have an internal spring to compensate for contraction and expansion.

4.6 Bracing

Braces shall be installed midway between the grade line and the top rail on all corner, pull, terminal, and gate posts. Bracing shall extend from these brace posts to the adjacent line posts, and diagonally trussed from its line post end back to the base of these posts. The 3/8-inch diameter truss rod shall be tensioned properly.

4.7 Tension Wire

The tension wire shall be installed with sufficient tension to maintain tautness during temperature changes and installed at 2 inches above finish grade. It shall be secured to the fabric and each line post, and terminated at each corner, gate, terminal, and pull posts.

4.8 Fabric

The fabric shall be installed only after the concrete has sufficiently cured (normally 7 days after placing), and all framework and braces have been installed. The fabric shall be stretched taut with its lower edge 1.5 inches above rough grade or subgrade. Panels of fabric shall be stretched between all terminal posts and terminated on stretcher bars which are held by fabric bands spaced not to exceed 15 inches. Portions of fabric shall be attached to the fence structure with the galvanized fastening types and maximum spacings specified below:

1. Top of fabric to top rail: Wire ties #9 gauge galvanized steel, 24-inch spacing
2. Center of fabric to bracing: Wire ties #9 gauge galvanized steel, 18-inch spacing
3. Width of fabric to line posts: Wire ties #9 gauge galvanized steel, 15-inch spacing
4. Bottom of fabric to tension: Wire ties or #11 gauge galvanized steel wire hog rings, 24-inch spacing

4.9 Gates

The normal drive gate should be a double-swing 24-foot 0-inch gate. A 4-foot 0-inch walk gate should also be installed, at a convenient location, but not as a part of the drive gate. Gates shall be erected so as to provide free and easy operation. Gate posts will not be used as corner posts for gates, nor located closer than 10 feet from a corner. However, gate posts may be used as corner posts for removable fence sections, if necessary (see subsection 7, Removable Fence Section). Braces shall be installed on each side of all gates. The top of the gate frame and the barbed wire shall be aligned vertically. Horizontal brackets

and 2 strands of barbed wire shall be mounted as shown on Figure 3 so as to clear the gate posts. The lower edge of the bottom rail shall be no more than 2 inches above finished grade.

4.10 Warning Signs

Warning signs shall be placed on all gates and sides of fences with the distance between signs not to exceed 150 feet. The “Danger—High Voltage” sign shall be placed at eye level, 5 feet above ground level. The “No Trespassing” sign shall be placed immediately below it. Approved signs are listed below:

- Danger—High Voltage: SI# 7992686. For Spanish use: SI# 7992687.
- No Trespassing: SI# 8252306.

4.11 Inward-Opening Gate

In substations where there is limited property, such that the ground grid cannot be extended 3 feet out from the gate swing radius, the gate shall be limited to opening inward only, with gate catches installed as shown in Figure 1. Gates so designated shall be equipped with 180° hinges to restrict gate opening.

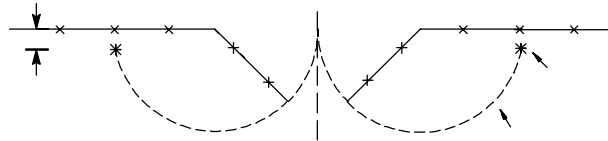

Figure 1 – Inward Gate Swing

In substations where the ground grid has been extended outside the gate swing radius, gate catches shall be installed as shown in Figure 2.

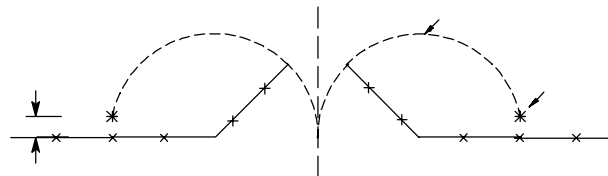

Figure 2 – Outward Gate Swing

4.12 Cleanup

Pieces of fencing or other scrap materials shall be removed. Dirt from excavations and left over concrete shall be removed or deposited as instructed by PacifiCorp representative and the area shall be left clean and orderly.

*See subsection E for material requirements, post and framework dimensions. These vary depending on steel type and usage (see Table 1).

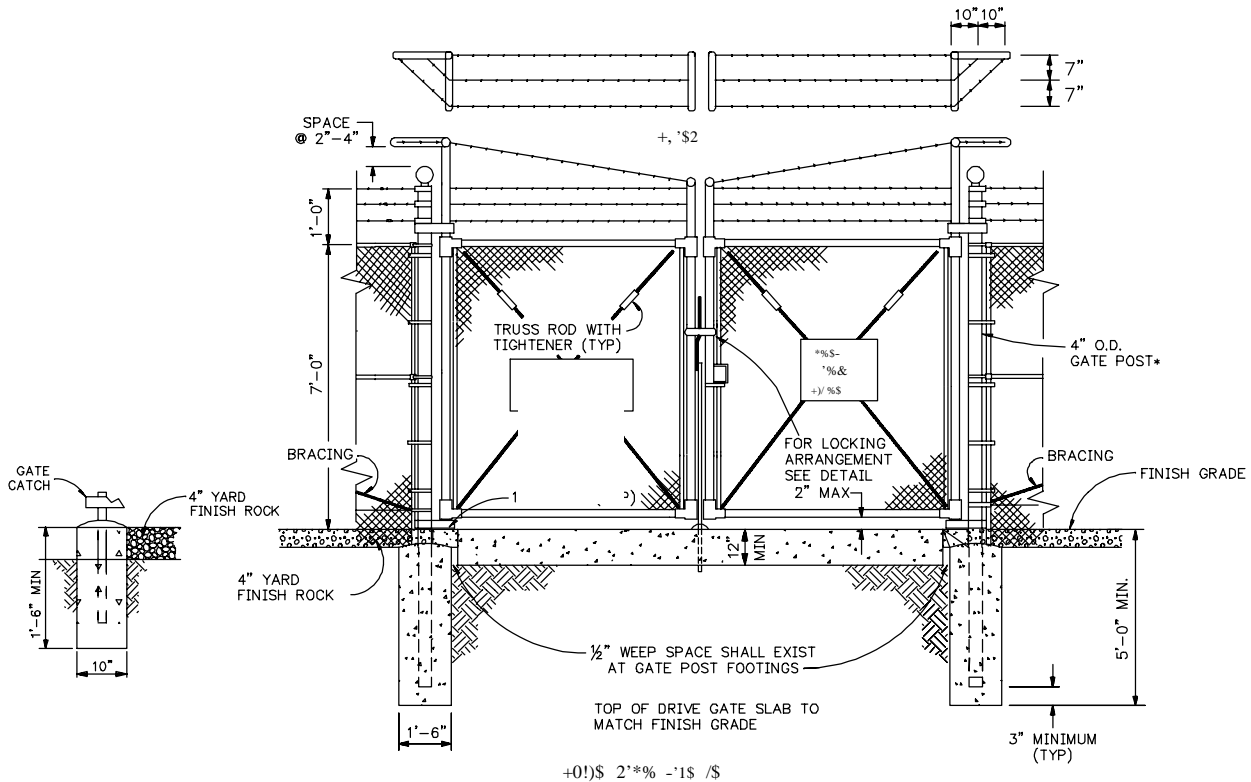

Figure 3 – Standard Gate Construction

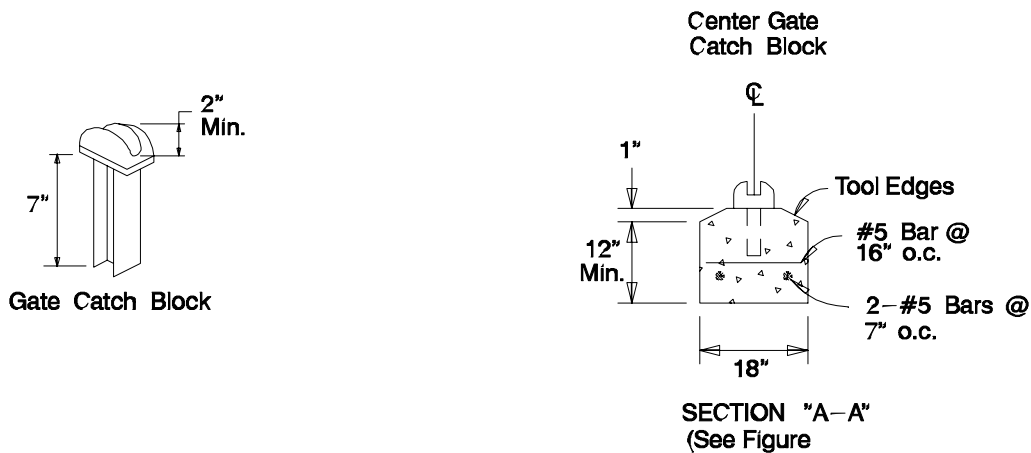

Figure 4 – Gate Catch Details

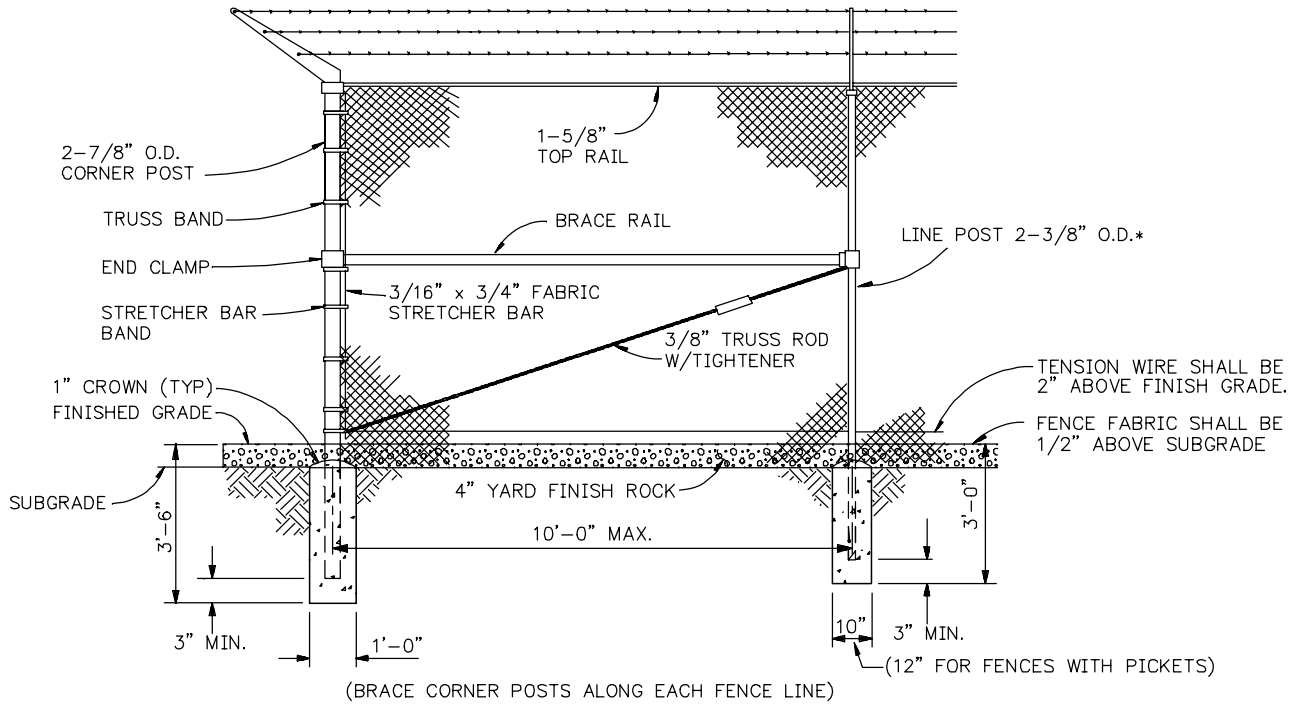

Figure 5 – Standard Fence Corner Construction

*See subsection E for material requirements, post and framework dimensions. These vary depending on steel type and usage (see Table 1).

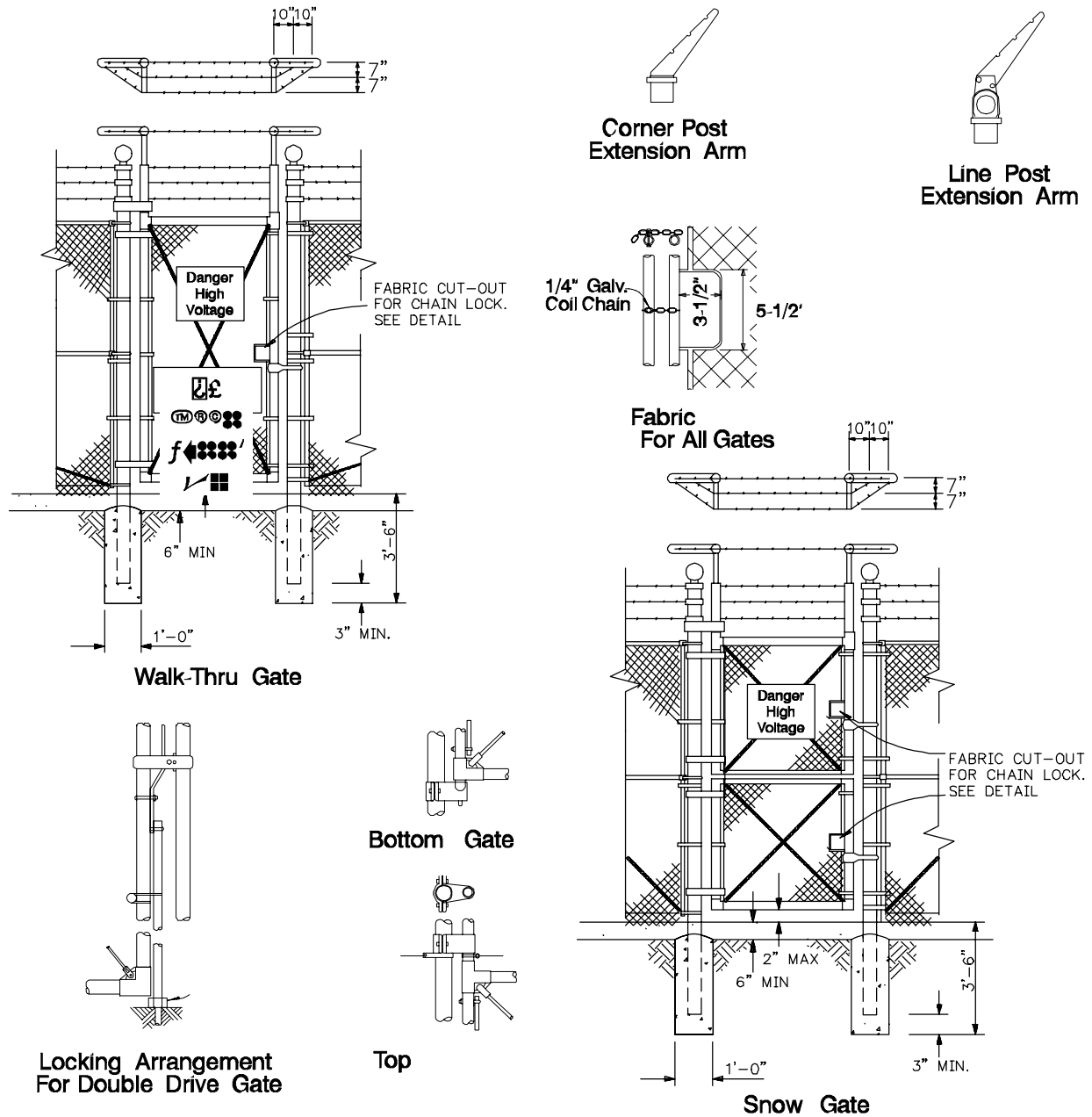

Figure 6 – Standard Fence and Gate Construction Details

5 Fence Material Specifications

5.1 Fabric

Fence fabric shall be 7 feet and shall conform to ASTM A392 latest revision. Fabric shall be made from #9 galvanized wire helically wound and interwoven into a 2-inch diamond mesh with twisted and barbed selvage at top and bottom. Minimum tensile strength of the wire shall be 90000 psi before zinc coating and 80000 psi after zinc coating. Wire shall be galvanized with a minimum weight of 1.20 ounces of zinc per square foot of uncoated wire surface. Fabric shall withstand a test of galvanizing according to ASTM A90 latest revision.

5.2 Framework

Post and framework dimensions may vary depending on steel type and application (see Table 1 for details). Fence frame work shall conform to ASTM F669. Framework shall be group IA, group IC, or group II, as defined below. Size tolerances shall be $\pm 5\%$ on weights. Lengths shall be sufficient for depth of required concrete embedment and barbed wire attachment. Use of rerolled, regalvanized or open seam posts or rails is not allowed.

Group IA pipe shall have 1.8 oz minimum hot-dipped zinc per square foot of surface. Schedule 40 pipe shall conform to ASTM F1083.

Group IC pipe shall be made from steel complying with ASTM A446 grade D or ASTM A569 with minimum yield strength of 50 000 psi. The pipe exterior shall conform to ASTM F1234, type B hot-dipped galvanized, 0.9 oz minimum hot-dipped zinc per square foot of surface. The exterior chromate coating shall be 30 ± 15 micrograms per square inch and polymer coating shall be 0.5 ± 0.2 mils thick. The interior shall conform to ASTM F1234, type B hot-dip galvanized 0.9 oz per square foot zinc.

Table 3 – Fencing Framework Sizes

<u>Description</u>	<u>Size (Diameter)</u>	<u>Weight (lb/ft)</u>
Line Posts (without pickets)		
Group IA	2 3/8"	3.65
Group IC	2 3/8"	3.12
Line Posts (with pickets)		
Group IA	4"	9.10
Group IC	2 7/8"	4.64
Terminal Post—End, Corner & Pull Posts (without pickets)		
Group IA	2 7/8"	5.79
Group IC	2 7/8"	4.64
Terminal Post—End, Corner & Pull Posts (with pickets)		
Group IA	4"	9.10
Group IC	2 7/8"	4.64
Top Rails and Braces (with or without pickets)		
Group IA	1 5/8"	2.27
	1 5/8"	1.84
Gate Frames (with or without pickets)		
Group IA	1 7/8"	2.72
Group IC	1 7/8"	2.28
Gate Posts, for Nominal Width of Gate Leaf (with or without pickets)		
<u>5 feet and less</u>		
Group IA	2 7/8"	5.79
Group IC	2 7/8"	4.64
<u>6—12 feet</u>		
Group IA	4"	9.10
Group IC	4"	6.56

5.3 Fittings

All fence fitting shall comply with ASTM F626. Fittings shall be from malleable or pressed steel. No aluminum fittings are allowed.

5.3.1 Post Tops

All intermediate or line posts shall be fitted with 45 ° barbed wire support arms with wire positioned outside the fence. Arms shall be 14 gauge pressed steel or malleable iron designed to hold the top rail and three strands of barbed wire with the top strand located 12 inches above the fabric. Arms having projections to be bent down over barbed wire may not be used. Tubular posts shall be equipped with tops designed to exclude moisture from the posts.

5.3.2 Rail and Brace Ends

Rail and brace ends shall be provided where top and brace rails are required. Rail and brace ends shall be fabricated from pressed steel or cast iron and shall be galvanized.

Top rail sleeves shall be fabricated from pressed steel, 0.051-inch wall thickness, and galvanized. Sleeves shall be not less than 6 inches long with expansion sleeves provided at every fifth sleeve.

5.3.3 Tie Wires

Tie wires shall be 9 gauge, galvanized steel, class 3.

5.3.4 Hog Rings

Hog rings shall be 11 gauge galvanized steel, class 3.

5.3.5 Fabric Stretcher Bars

Fabric stretcher bars shall be 3/4 inch wide and 1/4 inch thick, minimum.

5.3.6 Tension, Brace, and Top Rail Band

Tension, brace, and top rail bands shall be 1 inch wide and 1/8 inch thick, minimum.

5.3.7 Bolts, Nuts, Truss, and Turnbuckles

Bolts, nuts, truss, and turnbuckles shall be 3/8-inch, minimum, galvanized steel.

5.3.8 Gate Fittings

Corners, padlock fittings, hinges and latches shall be of heavy malleable castings or pressed steel. hinges shall be of ball and socket type. Hinges which pivot on pins and bolts are not acceptable. Gate stops and catches for each leaf of drive gates will be furnished and installed.

5.3.9 Barbed Wire

Barbed Wire: Barbed wire shall be made of two strands of galvanized twisted 12 1/2 gauge carbon steel wire per ASTM A121, class III. Barbs shall be four-point pattern

on approximately 5-inch centers. Barbs shall be 14 gauge carbon steel wire. Aluminum alloy 5052-H38 may be substituted in lieu of carbon steel wire.

5.3.10 Tension Wire

Tension Wire: Tension wire shall be #7 gauge spring coil wire with type II, class 2 galvanized coating per ASTM A824, latest revision.

5.4 Pickets

Pickets shall be manufactured from virgin high-density polyethylene and shall be unaffected by prolonged exposure to ultraviolet light. The picket system shall include means to lock pickets in place. Pickets shall be sized for 2-inch diamond mesh fabric as called for in subsection 55.1. Use of factory installed pickets with a 3-inch by 5-inch diamond mesh fabric is not allowed unless approved by PacifiCorp.

6 Fence Isolation Sections

When a PacifiCorp substation fence is to be adjacent to any other fence, the intermediate section of fence must isolate the two sections of fence as shown in Figure 7.

6.1 Existing Terminal Post

The existing customer's terminal post must be extended to the height of the company's fence. A barb wire barrier may need to be constructed to insure that barbed wire extends to the top of the terminal post.

6.2 Insulation From the Isolation Section Of Fence

This isolated section of fence shall be completely insulated from the grounding system.

6.3 Terminal Post

The terminal posts of the isolated fence section shall be grouted in 6-inch PVC conduit type EB after PVC is placed in cement footings. PVC end caps shall be placed at the bottom of the conduit.

6.4 Additional Information

For further information about isolating a fence section, contact the Substation Engineering Department.

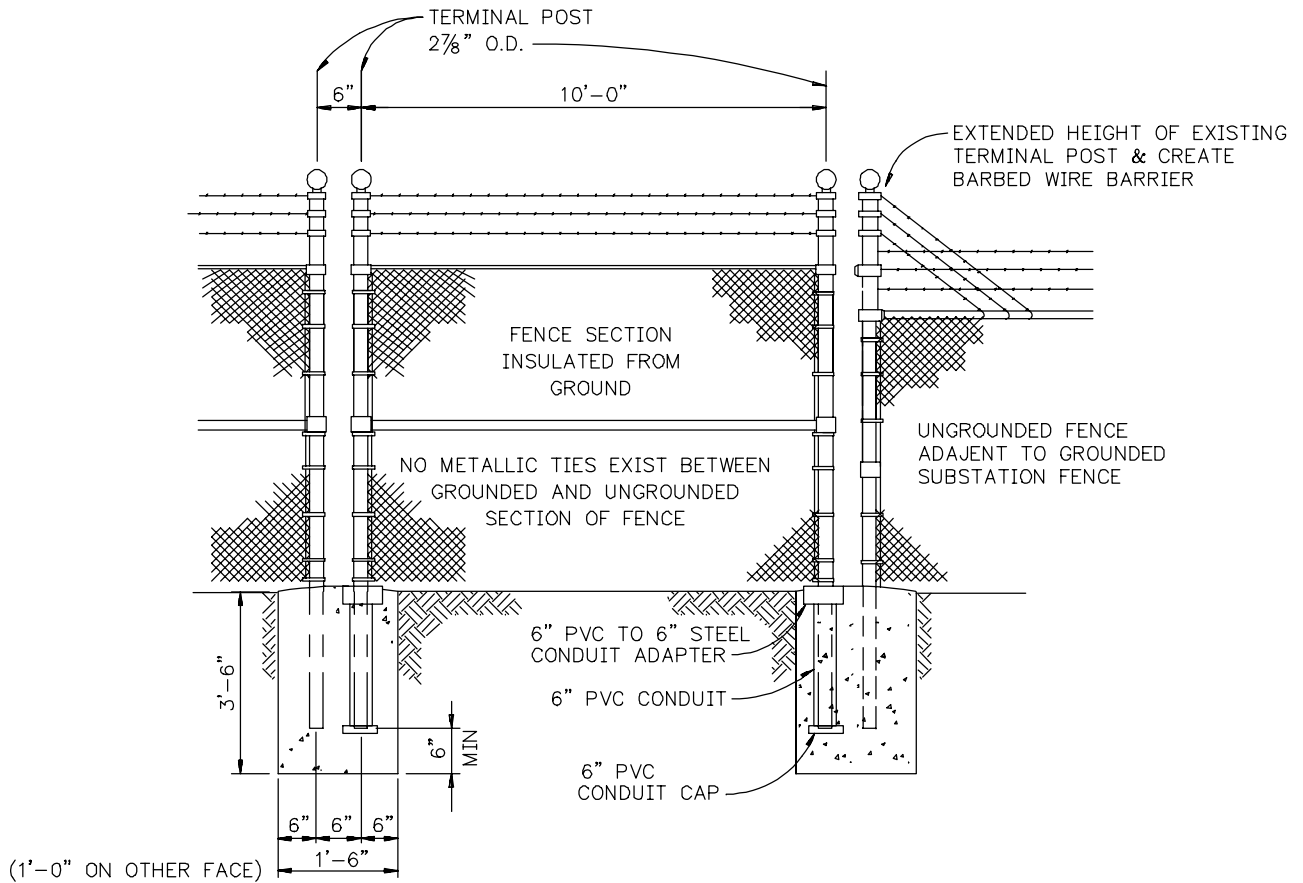

Figure 7 – Insulated Fence Panel

7 Removable Fence Section

A removable fence section may be required in substations with limited property to facilitate the removal of station equipment. A gate should be installed instead of a removal section, if possible. The removable section shall be constructed as shown in Figure 8 and per material specifications detailed in subsection 5, *Fence Material Specifications*. Gate posts are used for removable fence sections, which may be located at a corner (see 4.9).

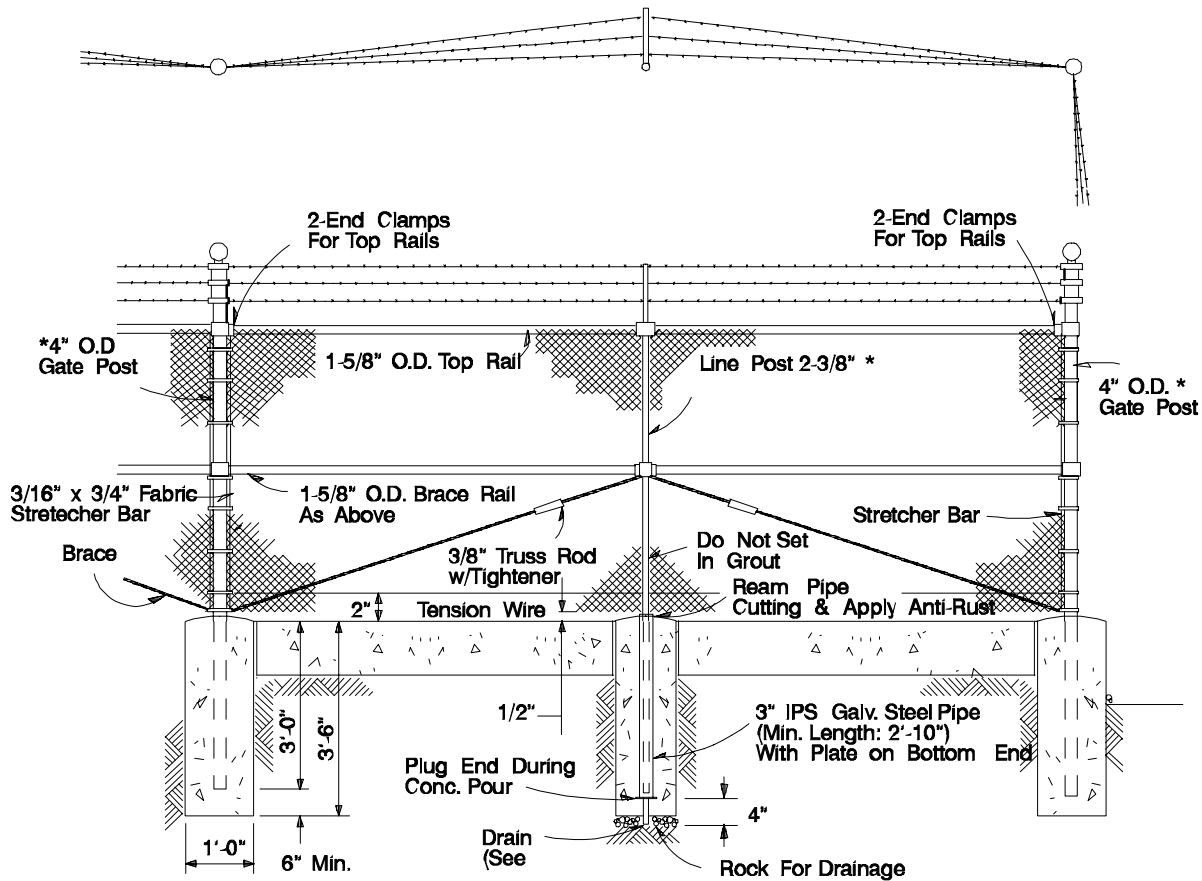

Figure 8 – Removable Fence Section, 16-foot

*See subsection 5 for material requirements for fences with pickets.

8 Curbed Fence Standards

Curbed fences shall be installed in strict compliance with furnished plans and PacifiCorp standards. Curbed fences shall only be installed in substations located in urban residential areas or in substations where curbing the perimeter is the most cost effective way to install oil containment. A minimum of a 6-inch x 6-inch concrete curb shall be installed, except at drive gate locations. Curbing shall be installed so top of concrete is flush, or slightly above finish rock surface. The fence fabric shall be 1/2 inches above top of concrete and tension wire shall be 2 inches above top of concrete. Refer to Figure 9 for details for a curbed fence. Fence material specifications are specified in subsection 5, *Fence Material Specifications*. If curbing is used for oil containment, the expansion joint material should be used in the weep space.

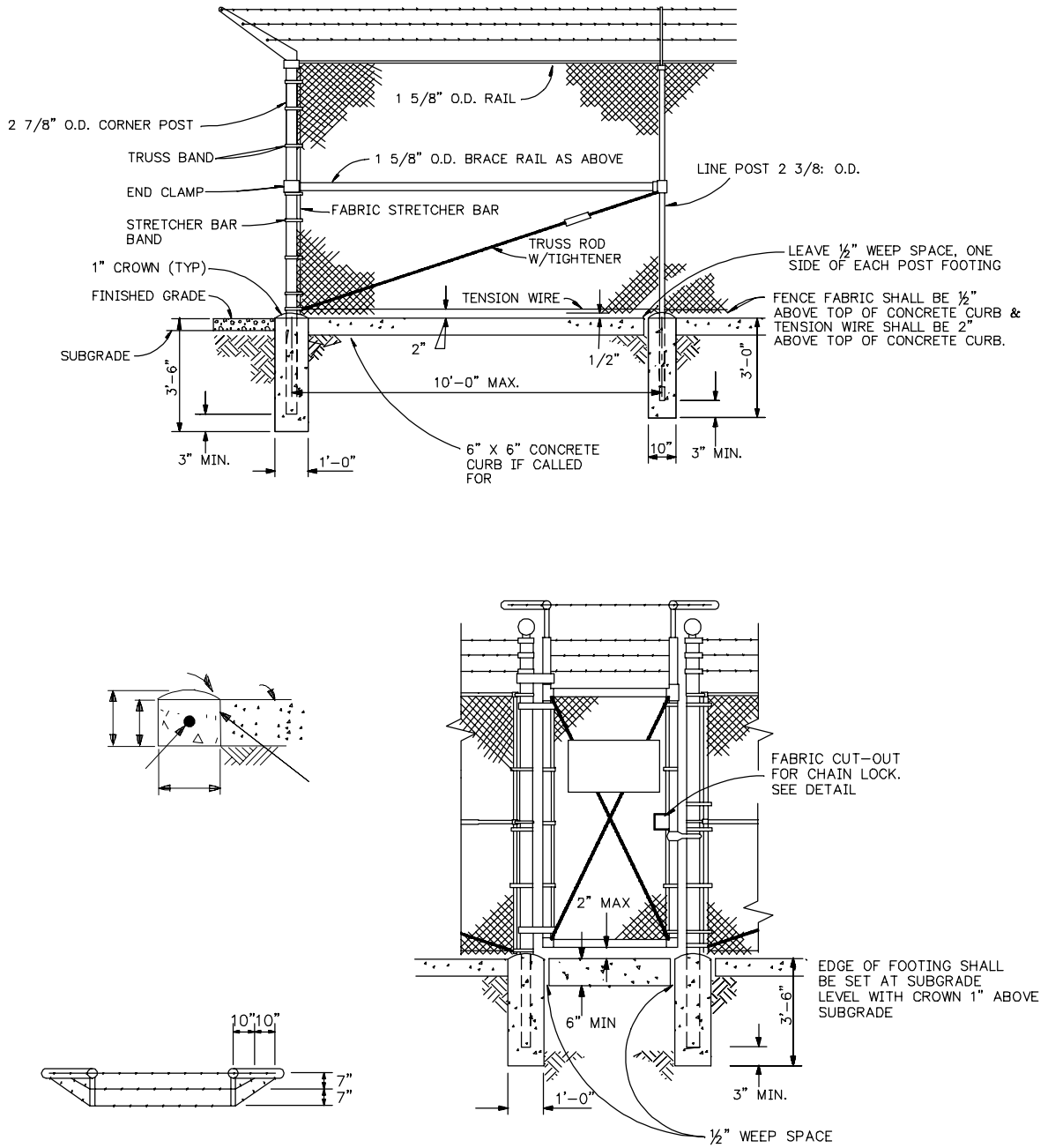

Figure 9 – Curbed Fence Standard

9 Fence Safety Clearances

Table 2 and Table 3, respectively, show safety and operating clearance zones that should be maintained when designing the substation fence location. This safety zone is designed to prevent contact with live parts by a person inserting an object through the substation fence. The fence should be located such that all live parts are outside the safety zone. The operating clearance zone is designed to allow adequate room between the fence and equipment for operation and maintenance purposes. The most stringent of the two requirements shall govern when designing the fence location. See Figure 10 for an example of a 12.5 kV substation.

Table 4 – Fence Safety Clearances
 (Dimensions for use with Figure 10)

Nominal Voltage (between phases)	Dimensions “A” (Vertical)		Dimension “B” (Horizontal)	
	(volts)	(feet)	(meters)	(feet)
151–34500	15.0	4.6	10.0	3.1
46000–69000	16.0	4.9	12.0	3.7
115000	16.7	5.1	13.0	4.0
138000	17.1	5.2	14.0	4.3
161000	17.6	5.4	14.0	4.3
230000	19.0	5.8	16.0	4.0
345000	21.3	6.5	18.0	5.5
500000	24.9	7.6	21.0	6.4

Table 5 – Fence Operating Clearances
 (Dimensions for use with Figure 10)

Equipment Type	Dimension “B” (Horizontal)
Fuse Structure of Disconnect Switches	20 feet
Operation Handles of Airbreak Switches	15 feet
Structures where there is no equipment	10 feet

NOTES:

1. Dimension A is equal to the vertical clearance of wires, conductors, and cables above spaces and ways subject to pedestrians or restricted traffic only (ANSI C2-1987 [1], rules 232A and 232B, and table 232-1, 5) for the voltage considered.
2. The B dimension was established after considering the horizontal clearance of unguarded live parts in electric-supply stations (ANSI C2-1987 [1], rule 124 A and table 124-1), plus

the effective length of a rod or pole that could be inserted through the electric-supply station fence. The horizontal clearances used for the extra-high voltages are based on BIL factors fence. (ANSI C2-1987 [1], table 124-1, part C).

3. The values shown for dimension A for nominal voltages between phases of 115 kV and above should be increased 3% for each 1000 feet (300 m) in excess of 3300 feet (1000 m) above mean sea level.

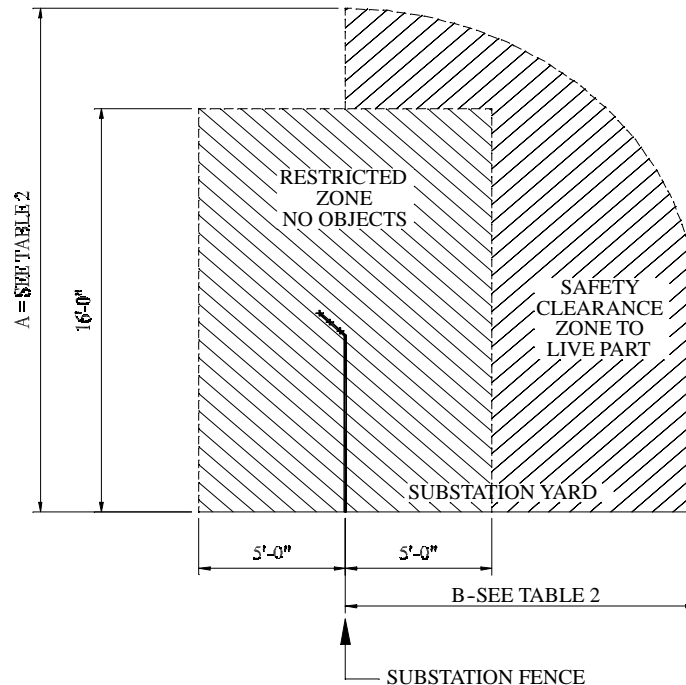

Figure 10 – Safety Clearance for Substation Fence

10

Fence Relocation

10.1 Expansion of Substations

When so specified in the contract documents, portions of an existing fence shall be removed and relocated (only if existing fence meets current 8-foot 0-inch height requirements), in accordance with these specifications and drawings furnished. The following fence materials shall be reused: Fabric, bracing and top railing. Reused fence materials shall be removed and handled with care so as not to damage them. New bottom tension wire must be installed and fence posts shall not be reused. All fence materials which are not reinstalled shall be returned to the nearest PacifiCorp warehouse unless stated differently in contract.

When relocating an existing fence, the contractor shall coordinate the work so that security is maintained at all times.

10.2 New Fence to Existing Fence

When enlarging a substation by installing a new fence to an existing substation, the new fence shall meet the current fence height standard of 8 feet 0 inches (including barb wire). Figure 11 shows how to join the unequal height fence sections.

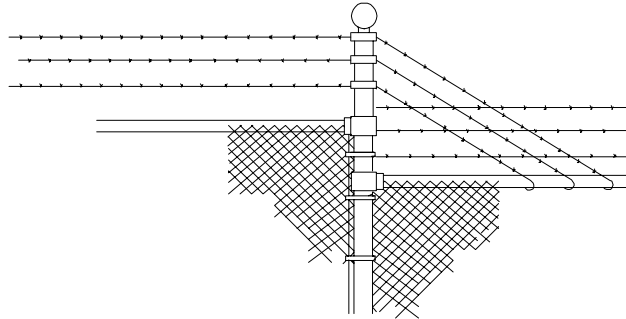

Figure 11 – Joint Unequal Height Fence Section

11

Handbook Issuing Department

The Asset Management Document Services Department of PacifiCorp is responsible for issuing this document. Comments and suggestions are welcome. Additional copies may be obtained from:

Asset Management Document Services, Lloyd Center Tower
825 NE Multnomah St., Suite 1600, Portland, Oregon 97232
Telephone: (503) 813-5293 Fax: (503) 813-6804

Technical questions regarding the content of this document may be directed to PacifiCorp Standards Engineering, (503) 813-6883. Publication and use of this document is authorized by the Manager of Standards Engineering when the block below has been signed.

Approved: 
Sikhiu Huynh, Engineer
Technology Development

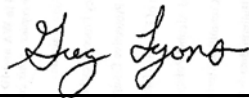
Approved: 
Greg Lyons, Manager
Standards Engineering and Technology Development

APPENDIX M

ENGINEERING DOCUMENTS, DRAWINGS AND OTHER DELIVERABLES

Engineering Documents, Drawings and Other Deliverables

1.0 General

To facilitate Company's review in accordance with the terms of this Contract, the following submission requirements shall be met by the Contractor.

All transmittals are to clearly indicate the Company's name, Contractor's project number, Company's project number and name, how they are being sent, and the reason for the submittal. The transmittal should include a clear, concise description of all documents enclosed. Documentation by drawing number, revision number, and date should be indicated, if applicable. Distributions to other parties are to be shown on the face of the transmittal.

All documents prepared by Contractor or any of its Subcontractors shall be in English and shall bear the project number, name. Each document shall clearly indicate the applicable status, e.g. Preliminary, for Information, for Review, for Bid, for Construction, As Built.

All drawings, documents and manufacturer information shall indicate the Company as the final owner, Contractor shall ensure that the Company is listed as the owner of record with all subcontractors and manufacturers providing any material or equipment for the project.

The measurement system shall be U.S. Customary System, and all drawings and dimensions shall be to scale. Non-scale dimensions (NTS) on drawings will not be permitted on scalable drawings. A scale bar shall be included to permit use following photo-reduction.

All drawings shall be prepared per PacifiCorp Energy's General AutoCAD/Drafting Standards hereafter referenced as (Specification DCAP876). Drawings shall be prepared on PacifiCorp Thermal Group borders. If contractor is unable to provide drawings on said borders, a complete drawing index must be provided using the drawing index template provided with Specification DCAP876 and associated documents.

Acceptable drawing sizes are indicated in Specification DCAP876. Drawings shall be prepared in such a way that photo-reduction to B size shall result in a legible and useable drawing. When drawings larger than B size are submitted, a B size print shall also be submitted.

2.0 Design Review By Company

Contractor shall provide any and all information upon which the design is

based, including, but not limited to the results of survey, geotechnical and materials investigations, design calculations, shop drawings, design drawings and manufacturers' data.

Contractor and Subcontractor generated drawings and documents shall be issued to Company for review. The final level of drawing and document review, including quantity required, shall be determined at the project kickoff meeting. Electronic AutoCAD files of drawings and other documents shall be submitted in addition to the hard copies as a part of the same transmittal and provided on Compact Disc (CD). These electronic drawings will be checked by Company for compliance to documentation standards.

Except where expressly agreed otherwise by Company, the following will apply to document submittals by Contractor or Subcontractors:

- a. Drawings: Full size prints of the size customary for the type of drawing and at least one copy in "B" size (11" x 17" format). In addition, one copy shall be submitted in electronic form ("PDF" or comparable for design and construction drawings only). Final drawings shall be AutoCAD and must not be a newer version than that which is currently being used by PacifiCorp Energy.
- b. Documents: Letter size hardcopies and one electronic copy shall be provided for written text such as letters, specifications, procedures, calculations, manuals, lists, etc. in Microsoft Word or Excel format.
- c. Drawings and Documents: Contractor shall make reasonable efforts to secure electronically formatted drawings and documents from all Subcontractors. When electronic formatting as noted in "a" and "b" above is not obtainable due to supplier policies or procedures then Contractor shall have such materials converted and submitted in ".tif" or ".pdf" format.

Subcontractor drawings and documentation shall also be submitted in hardcopy and electronic format to Company as described above. Company may make comments to Contractor on Subcontractor drawings and documents if items are found not to be in compliance with the requirements of this Contract. Contractor shall be obligated to resolve any such compliance issues with Subcontractor in a timely manner and resubmit Subcontractor drawings and documents.

3.0 Deliverables

The Contractor shall submit general specifications covering the type and design of all principal components of the equipment, when specifications have not already been provided in the Contract.

Materials shall be fully identified by the Contractor.

The Contractor shall submit a complete bill of materials and list of all instruments and accessories supplied for each equipment category or specification. Contractor shall submit all bills of materials and equipment identification information electronically to the Company.

The Contractor shall be responsible for the coordination with Company or Company's contractors for necessary interfaces. At the same time a copy of the interface information shall be submitted to the Company for review. The Contractor shall plan for the exchange of information in order to ensure the completion of the whole project to meet the schedule requirements of the Contract.

The Contractor shall submit detailed procedures for testing, commissioning and putting into operation all equipment as required.

The Company will not necessarily examine all details submitted by the Contractor and may at Company option require submittal to be subject to review or regard them as for information and record purposes.

The Contractor shall be responsible for any discrepancies, errors, or omissions on the drawings supplied by Contractor or Subcontractors.

The Company shall require the Contractor to make any changes to the drawings and data, which may be necessary to make the work conform to the Contract.

Any work done before the review of the drawings and data shall be at the Contractor's risk and any necessary design changes to comply with the requirements and objectives of the Contract shall be made at no additional cost to the Company or delay to the project.

Contractor Deliverables supplied to Company shall include but are not necessarily limited to:

- A complete drawing index, in an Excel compatible file format per Specification DCAP876. Index shall include all Contractor and Sub-Contractor drawings.
- Diagrams - electrical one-line, electrical three-line, schematic, wiring including relay/control schematics, logic, SCADA and communication block diagrams.
- Physical arrangement and equipment drawings including site grading, equipment arrangement, building arrangement, civil, raceway and power, structure drawings, and underground utilities. The specific list of drawings to be provided shall be determined by Company after consultation with Contractor.
- Drawings of all equipment foundations showing all structure and

equipment outline requirements including anchor bolts and foundation loads that are to be used in the design of the foundations.

- Internal panel component arrangement drawings including terminal block size, location, spacing and types.
- Equipment, instrument, device, cable/conduit/raceway, and electrical load lists and schedules.
- Instrument manuals and data sheets (including protective and auxiliary relays, etc).
- Equipment manuals and data sheets
- All drawings used for construction.
- Design Statements - Overall design concept and detailed design criteria including design calculations.
- All Subcontractor's drawings, documentation, and manuals including outline drawings.
- Schedules, including engineering, procurement, construction and integrated Critical Path Schedule.
- Project procedures manual - Procedures for design, review and comment or approvals, procurement, construction, scheduling, progress reports, etc.
- Quality assurance and quality control program manuals.
- Environmental protection manual
- Construction safety assurance plan.
- Procurement specifications.
- Erection specifications and procedures.
- Material instruction bulletins and cut sheets.
- Contractor Acquired Permits.
- Monthly Progress Report.
- Meeting minutes and reports.
- Instructions for handling, storage, and pre-operational and operational maintenance of equipment.
- Testing and commissioning plans and reports.
- Site and shop inspection and testing plans and requirements.
- Material safety data sheets for all applicable materials and equipment.
- Test procedures including Site and shop testing plans and requirements.
- Test reports or other required reports.
- Final commissioning and acceptance reports.

4.0 Final Drawings

Contractor shall provide detailed "as built" drawings for the entire project consisting of, but not limited to, plan and profile sheets, and foundation detail drawings, mechanical, electrical, civil, one-line, three-line, schematics, control logic, wiring, raceways, conduits and duct banks. Documents shall be re-drafted as necessary to incorporate final information. Mark-up sketch, referencing, and other field marking techniques are not acceptable as final as-

built drawings. Contractor shall prepare "as-builts" of the original drawings or data sheets.

During construction, Contractor shall update and maintain on file in the field current mark-ups of all drawings and data sheets to agree with actual work undertaken.

"As-builts" shall be issued as the next sequential revision from previous releases. The revision block shall state "As-Built". All clouds, revision diamonds, and other interim control marking shall be removed. All information listed as "later" or "hold" shall be completed. The "as-builts" shall be clear and readable in both full size and B size reduction. Contractor shall provide new versions of Subcontractor drawings if the Company judges originals to be too damaged, deteriorated, or illegible.

All Subcontractors' drawings shall be "as-built" to reflect actual installed configuration. These Subcontractor drawings shall be in sufficient detail to indicate the kind, size, arrangement, weight of each component, and operation of component materials and devices, the external connections, anchorages, and supports required; the dimensions needed for installation, and correlation with other materials and equipment. Final Subcontractor's drawings shall be bound in the equipment O&M Manuals. One electronic copy for each drawing shall be supplied in AutoCAD format. (The AutoCAD version shall not be newer than current version being used by PacifiCorp Energy).

Drawing Information:

All AutoCAD and drawing requirements are per Specification DCAP876 and associated documents. This specification includes, but is not limited to, information on the following:

- PacifiCorp Title Block Information. /Borders are provided and required.
- Drawing numbers shall conform to the existing specific plant numbering guidelines. If there are no existing guidelines that apply, PacifiCorp will supply new numbers that can be used.
- Indexes, lists, data sheets, and schedules per Specification DCAP876, or other if approved.
- Drawing revisions.

5.0 Lists

All lists, including but not limited to drawing lists, instrument lists, equipment

lists, circuit lists, raceway lists, conduit lists, piping and accessories lists, bills of materials, etc. shall be furnished in an Excel compatible file format per Specification DCAP876, or other if approved.

Instrumentation Lists and Data Sheets:

- All instruments shall be given a “Tag Number” composed of two to four alpha characters and a three digit numeric reference per the Instrumentation Society of American standards and existing specific plant procedures.
- The “Tag Number” will be used to reference all instruments on drawings, instrument indexes and data sheets.
- Data sheets for each instrument shall reference vendor, model numbers, conditions of service, construction material, specifications, etc.

Equipment Lists:

- All equipment shall be given a “Tag Number” identifying the type of equipment, the media that it services and a numeric reference per existing specific plant procedures.
- The “Tag Number” will be used to reference all equipment on drawings, instrument indexes and data sheets.
- Equipment indexes shall reference service location, drawing references, rating, manufactures, data sheet locations, etc.

Electrical Circuit Schedule:

- All electrical cables shall be given a “Circuit Number” that meets specific plant requirements. Information on the existing system will be provided upon contractor selection.
 - Cable Numbering
Cable numbering shall sequentially follow the existing specific plant numbering system. Multi-Conductor Signal Wire:
 - Multi-Conductor Signal Wire:
Multi-conductor signal wire color scheme shall match the existing specific plant system.
- The “Circuit Numbers” will be used to reference all equipment on

drawings, instrument indexes and data sheets.

- Circuit indexes shall reference service location, drawing references, rating, manufactures, data sheet locations, etc.

Piping Line List:

- All piping shall be given a “Line Number” that shall match the existing specific plant system.
- The “Line Number” will be used to reference all pipes on area/routing drawings, indexes and line lists.
- The line list shall contain line sizes, description of starting and ending location, operating and design location, insulation, drawing references, etc.

6.0 Software Requirements

All Contractor Deliverables including final drawings, lists, and manuals shall be provided to the Company in the appropriate file format listed below. This requirement pertains to both Contractor developed deliverables as well as OEM developed deliverables.

All Contractor Deliverable lists, provided in database format, shall be designed to be integrated into Company's existing applications. Company will provide Contractor with formatting information as required.

Contractor shall provide electronic submittals in the following software formats:

Software Function	Software Name
Word processing	Microsoft Word
Spreadsheets	Microsoft Excel
Database	Microsoft Access
Design/Construction & Original OEM Drawings	AutoCAD version no newer than that currently being used by PacifiCorp Energy. Drawings in PDF format are only acceptable for design and construction phases of the project. (See specification DCAP876.)
Project Schedules	Primavera 5 level 3 format
Scannable Material	Adobe Acrobat ".pdf" or ".tif"

7.0 Submission of Drawings and Data

The documents and drawings for review, comment, or approval, as the case may be, shall be submitted to the Company. The mailing address to the Company is:

PacifiCorp
Attn. Contact person
Specific plant information

An additional copy (or copies) may be directed to other Owner addresses or to Owner's Engineer as requested.

Drawings shall be updated as the design progresses so that they continuously reflect the current design(s). Revisions shall be identified per specification DCAP876.

No design drawings, data, etc., which are incomplete and not authorized by Contractor's project manager shall be considered available for review.

The Owner shall review the drawings, data, etc., for conformance with the Contract and will mark or stamp to indicate whether changes or corrections are required. If changes or corrections are necessary, such changes or corrections will be noted on the drawings and returned to the Contractor. The Contractor shall resubmit the corrected or changed drawings, with changes and corrections clearly indicated.

When no further corrections or changes to the drawings submitted by the Contractor are required, these drawings shall be marked "Approved for Construction." The Contractor shall supply one (1) reproducible and one (1) electronic copy for each of the "Approved for Construction" drawings to Owner for record. The Owner will inform the Contractor when these final drawings have been received.

Design information may later be included on the certified drawings. The fact that such design information may later be included in the instruction and/or operating manuals does not relieve the Contractor from compliance with this requirement.