

Exhibit A

POLE ATTACHMENT AGREEMENT

BETWEEN

ROCKY MOUNTAIN POWER

AND

ZAYO GROUP, LLC

Article I.	DEFINITIONS	1
Article II.	SCOPE OF AGREEMENT	3
	Section 2.01 Grant of License; Geographic Scope	3
	Section 2.02 Attachments; Purpose	4
	Section 2.03 Reservation of Rights.....	4
Article III.	LICENSEE’S USE OF POLES	5
	Section 3.01 Application for Permission to Install Attachment	5
	Section 3.02 Make-ready Work	5
	Section 3.03 Licensee’s Installation Responsibilities	7
	Section 3.04 Identification of Equipment	8
	Section 3.05 Conformance to Requirements and Specifications	8
	Section 3.06 Nonconforming Equipment	9
	Section 3.07 Interference with Rocky Mountain Power’s Equipment	9
	Section 3.08 Expense of Situating Pole Attachments	9
	Section 3.09 Vegetation Management	10
	Section 3.10 Third-party Consents, Permits, Licenses, or Grants	10
	Section 3.11 Relocation of Attachments at Rocky Mountain Power’s Option.....	10
	Section 3.12 Removal of Attachments by Licensee	11
	Section 3.13 Damage to Equipment.....	11
	Section 3.14 Inspections and Audits.....	11
	Section 3.15 Tax Liability.....	12
Article IV.	RENTAL PAYMENTS; FEES	12
	Section 4.01 Rental Amount	12
	Section 4.02 Attachment Space	13
	Section 4.03 Unauthorized Attachments.....	13
	Section 4.04 Billing and Payments	13
	Section 4.05 Interest on Late Payments.....	14
Article V.	INDEMNIFICATION; LIMITATION OF LIABILITY; WARRANTIES	14
	Section 5.01 Indemnification/Release	14
	Section 5.02 Warranty	15
Article VI.	INSURANCE, SECURITY AND CREDIT REQUIREMENTS	15
	Section 6.01 Insurance	15
	Section 6.02 Additional Insurance Requirements.....	16
	Section 6.03 Security	16
	Section 6.04 Credit Requirements	17

Article VII. TERM, DEFAULT AND TERMINATION	18
Section 7.01 Term and Termination	18
Section 7.02 Default.....	18
Section 7.03 Notice of Default/Cure Period	18
Section 7.04 Remedies for Default	18
Article VIII. GENERAL PROVISIONS.....	19
Section 8.01 Entire Agreement.....	19
Section 8.02 Choice of Law/Venue	19
Section 8.03 Changes in Law.....	19
Section 8.04 Severability	19
Section 8.05 Encumbrances	19
Section 8.06 Headings and Exhibits	19
Section 8.07 Force Majeure	19
Section 8.08 Assignments	20
Section 8.09 Waiver.....	20
Section 8.10 Time is of Essence	20
Section 8.11 No Partnership	20
Section 8.12 No Third-party Beneficiaries	20
Section 8.13 Attorneys' Fees	20
Section 8.14 Waiver of Jury Trial.....	21
Section 8.15 Agreement	
Notices.....	211
Section 8.16 Operational Notice	21

THIS POLE ATTACHMENT AGREEMENT (this "Agreement"), dated as of _____, 20__, is entered into by and between PACIFICORP, an Oregon Corporation, doing business in Utah as ROCKY MOUNTAIN POWER, hereinafter "Rocky Mountain Power," and ZAYO GROUP, LLC "Licensee", a Delaware limited liability company Corporation.

WHEREAS, Rocky Mountain Power is engaged in the business of providing electric service to customers in certain areas within the state of Utah; and

WHEREAS, Licensee conducts its telecommunications business in a number of the same areas within Utah; and

WHEREAS, Licensee desires to attach its fiber optic Equipment to Poles owned by Rocky Mountain Power within the state of Utah and Rocky Mountain Power desires to grant Licensee access to such Poles in accordance with the terms and conditions of this Agreement.

NOW, THEREFORE, the Parties agree as follows:

ARTICLE I. DEFINITIONS

The following terms, when used herein with initial capitalization, whether in the singular or in the plural, shall have the meanings specified in this Article I:

"Application" is an action where Licensee requests permission to add or modify its Attachment(s), or sends notification of its removal of previous Attachment(s). For each Application received, Rocky Mountain Power analyzes the data, updates its records, and responds to Licensee at least once per Application, regarding its approval or acknowledgement of the Application.

"Attachment(s)" means Pole Attachment(s) as defined in R746-345-2.E of the Utah Administrative Rules ("UAR"), except for antennas or other non-power utility Equipment placed on a Pole above any power conductors ("Pole-Top Attachment(s)").

"Attachment Space" shall have the meaning set forth in UAR R746-345-2.B.

"Business Days" means days other than a Saturday, Sunday, or state or federal holiday when banks are authorized to be closed.

"Commission" means the State of Utah Public Service Commission.

"Cost Estimate" means a Cost Estimate prepared by Rocky Mountain Power, based either on anticipated actual costs on each individual piece of work or flat rates for Make-Ready Work when included in the Fee Schedule (Exhibit B). Rocky Mountain Power reserves the right to determine when flat rates are applicable according to the specific situation.

POLE ATTACHMENT AGREEMENT ROCKY MOUNTAIN POWER AND ZAYO GROUP

“Credit Requirements” means the most recently published senior, unsecured long-term debt rating (or corporate rating if such debt rating is not available) of (a) “BBB-“or greater from S&P, or (b) “Baa3” or greater from Moody’s, or such other indicia of creditworthiness acceptable to Rocky Mountain Power in its reasonable judgment.

“Distribution Construction Standards” means the current Rocky Mountain Power Distribution Construction Standards attached hereto as Exhibit C, and any subsequent revisions thereof.

“Electronic Notification System” or “ENS” means the electronic system, or combination of electronic systems designated by Rocky Mountain Power in its sole discretion, Licensee may utilize to submit Applications for permission to attach, relocate, or remove its Equipment, and complete any other notifications as required under the terms of this Agreement.

“Equipment” means cables, wires, antennas, wireless communication devices, conductors, fiber optics, insulators, connectors, fasteners, transformers, capacitors, switches, batteries, amplifiers, power supplies, devices, structures, materials, machines, appurtenances, articles, or apparatus of any sort, whether electrical or physical in nature, or otherwise, including without limitation all support Equipment such as guy wires, anchors, anchor rods, grounds, and other accessories. This definition specifically excludes Licensee Pole-Top Attachments.

“Estimated Attachments” means the number of Attachments which Licensee, as of the date of this Agreement, estimates will be installed by Licensee pursuant to this Agreement, which estimate shall be provided to Rocky Mountain Power prior to, as of the date of Licensee’s execution of this Agreement.

“Fee Schedule” means the fees set forth in Exhibit B attached hereto, as may be amended from time to time in accordance with UAR R746-345-3.A.

“Inspection” means examination by Rocky Mountain Power of its Poles and all proposed or existing Attachments for the purpose of verifying the number and location of all Attachments and any other Pole-mounted Equipment of Licensee, or determining whether Licensee is in compliance with the terms of this Agreement, which includes the following five (5) types of Inspections:

1. Pre-Construction Inspection: Performed when Applications by Licensee are submitted for new Attachment.
2. Post-Construction Inspection: Performed when Licensee completes its construction of new, modified, or transferred Attachment(s). Also performed for verification of Licensee’s Attachment removal. Licensee may avoid a Post-Construction Inspection fee on transfer and removals of Attachments if an electronic photograph is provided to Rocky Mountain Power showing that the work is completed and in compliance with this Agreement.
3. Special Inspection: Rocky Mountain Power’s field visit made at the request of Licensee for all non-periodic Inspections. A Special Inspection does not include Pre-Construction Inspections or Post-Construction Inspection.
4. Audit: A periodic effort to collect information through examination by Rocky Mountain Power of all or any number of Poles that may have Licensee Attachments.

POLE ATTACHMENT AGREEMENT ROCKY MOUNTAIN POWER AND ZAYO GROUP

5. Periodic Safety Inspection: Any Inspection done by Rocky Mountain Power to review the safety and integrity of its Poles. If, upon inspecting a percentage of Licensee's reported corrections from a Periodic Safety Inspection that consists of a representative random sample and it is discovered that there is a failure rate of 15% or more, Rocky Mountain Power reserves the right to charge Post-Construction Inspection Fees for a complete re-inspection of the reported corrections.

"Make-ready Work" means all engineering, Inspection, design, planning, construction, or other work necessary, in Rocky Mountain Power's reasonable judgment, to prepare Rocky Mountain Power's Poles for the installation of Licensee's Attachments, including without limitation, work related to transfers, rearrangements and replacements of existing Poles or Equipment, and/or the addition of new Poles or Equipment.

"Material Adverse Change" means the occurrence of any event of default under any material agreement to which Licensee is a Party and of any other development, financial or otherwise, which would have a material adverse effect on Licensee, or on Rocky Mountain Power's ability to remove the Attachments or to have access to its Poles.

"National Electrical Safety Code" or "NESC" means the current edition published by the Institute of Electrical and Electronics Engineers, Inc., as may be amended or supplemented from time to time.

"Party" means Rocky Mountain Power or Licensee, as the context requires; "Parties" means Rocky Mountain Power and Licensee.

"Pole" means any Pole owned by Rocky Mountain Power that is designed to carry distribution as defined in R746-345-2.C of the Utah Administrative Rules.

"Security" means a bond, cash escrow, letter of credit or parental guaranty, acceptable in form to Rocky Mountain Power in its sole and reasonable discretion, to assure performance by Licensee of its obligations hereunder, which shall be in an amount sufficient to pay Rocky Mountain Power for the cost to remove and dispose of Licensee Attachments and related Equipment, plus two years' of rental payment obligations under this Agreement. The calculation of the cost to remove and dispose of Licensee's Attachments and related Equipment shall be Rocky Mountain Power's current hourly wage rate of a two-person crew multiplied by the number of Estimated Attachments. The calculation of Security shall be based on the number of estimated Attachments unless the number of Attachments exceeds one hundred twenty percent (120%) of the Estimated Attachments, in which case the calculation of Security shall be based on the number of actual Attachments.

ARTICLE II. SCOPE OF AGREEMENT

Section 2.01 Grant of License; Geographic Scope

In accordance with the terms and conditions of this Agreement, Rocky Mountain Power hereby grants Licensee the non-exclusive right to attach its Equipment pertaining directly to its business purpose as defined in Section 2.02. Licensee Attachments hereunder shall be limited to Rocky Mountain Power's Poles within the state of Utah.

POLE ATTACHMENT AGREEMENT ROCKY MOUNTAIN POWER AND ZAYO GROUP

Attachments shall not be permitted by Rocky Mountain Power on Poles which are not designed to accommodate distribution. Nothing in this Agreement shall be construed to obligate Rocky Mountain Power to grant Licensee permission to use any particular Pole or Poles.

With the exception of construction on existing slack spans or on existing messengers attached to Poles carrying voltages 34.5kV and above, Licensee may overlash forty-eight (48) and less count fibers, as well as coaxial cable of equivalent weight(s) without submitting a permit. For these specific instances of overlashing, Licensee will provide PacifiCorp with maps of the proposed overlash route and Pole numbers ten (10) days prior to such overlashing. Licensee agrees to correct any of Licensee's existing non-compliant Equipment at the time of the overlashing such that the Equipment conforms to requirements and specifications as outlined in Section 3.05.

Section 2.02 Attachments: Purpose

Licensee's use of Poles shall be confined to the Attachments which Rocky Mountain Power may give Licensee prior written permission to install for the sole purpose of providing: telecommunications (the "Permitted Purpose") service. This Agreement does not apply to Pole-Top Attachments.

In the event Licensee intends to expand or modify its Permitted Purpose, Licensee shall provide at least ninety (90) days advance written notice to Rocky Mountain Power. Following receipt of such notice, Rocky Mountain Power shall determine in its sole discretion, whether to permit the modification or expansion and if permitted, whether this Agreement shall be amended accordingly or whether Licensee shall be required to enter into a new agreement.

Section 2.03 Reservation of Rights

Rocky Mountain Power reserves the right, in its sole judgment, to reject Applications for Attachments to its Poles for the following reasons:

- a. Insufficient capacity - once all reasonable potential accommodations have been considered by Rocky Mountain Power and communicated to Licensee.
- b. The Poles are necessary for Rocky Mountain Power's own sole use or the Attachments would threaten Rocky Mountain Power's system reliability.
- c. The proposed Attachment is considered to be unsafe according to the NESC, Rocky Mountain Power's Distribution Construction Standards (Exhibit C) or Commission safety rules.
- d. Unreasonable interference with Rocky Mountain Power's or a third-party's Equipment.
- e. Licensee's account with Rocky Mountain Power is not current (i.e. all undisputed invoices are not paid on time).
- f. Licensee is in default of this Agreement.

POLE ATTACHMENT AGREEMENT ROCKY MOUNTAIN POWER AND ZAYO GROUP

ARTICLE III. LICENSEE'S USE OF POLES

Section 3.01 Application for Permission to Install Attachment

With the exception of service drops, as addressed in Section 3.03, and certain overlashing as addressed in Section 2.01, Licensee shall not have the right to place, nor shall it place, any Equipment upon Poles without first making Application and receiving permission to do so; nor shall Licensee modify the position of any Attachment upon any Poles without first making Application and receiving permission to do so.

Licensee shall apply for prior permission from Rocky Mountain Power to place any Equipment upon any Poles, or overlash its Equipment to any existing Attachments or other Equipment already attached to Poles, in writing or via the Electronic Notification System (ENS). The Application shall include, without limitation: all location information with Rocky Mountain Power's Pole numbers; description of Equipment to be attached; engineering information for the calculation of Pole loading, clearances and viability of each Pole to accept the Attachment; indication of required Make-ready Work as outlined in Section 3.02; and all applicable contact information for Licensee or Licensee's qualified contractor. Rocky Mountain Power will either approve or deny Applications in writing in accordance with the requirements of UAR R746-345-3.

Licensee shall promptly submit payment for all fees applicable to the assessment of proposed Attachments pursuant to the Fee Schedule (Exhibit B) upon receipt of an invoice from Rocky Mountain Power. Rental charges for each approved Attachment shall commence as of the date of Rocky Mountain Power's approval of the Application pursuant to the Rental Rate Schedule (Exhibit A) and the first charge for annual rent on the Attachment shall be due and payable at this time, with no abatement for the period of the current annual billing period prior to the Attachment approval. For illustrative purposes only, if the Attachment is approved in December and the current annual billing period is the prior July through the following June, for \$100 per Attachment, Licensee shall be charged \$100 in December for the new approved Attachment and then \$100 for the Attachment the following July for the next annual billing period.

Section 3.02 Make-ready Work

Licensee shall identify in its Applications any Make-ready Work necessary to accommodate its Attachments. If in the sole judgment of Rocky Mountain Power, the accommodation of any of Licensee's Attachments necessitates Make-ready Work, Rocky Mountain Power shall provide the Cost Estimate for the Make-ready Work in its response to Licensee's Application within the applicable Application processing time period identified in UAR R746-345-3. Licensee shall indicate whether it accepts or rejects the Cost Estimate by returning Rocky Mountain Power's Make-ready Work notice, signed by an authorized Licensee representative, within thirty (30) days of Rocky Mountain Power's Cost Estimate notice. Failure to reject the Cost Estimate within said period shall be deemed acceptance thereof by Licensee. If Licensee accepts or fails to timely reject the Cost Estimate, Rocky Mountain Power may perform such Make-ready Work, and Licensee shall reimburse Rocky Mountain Power for the entire expense thereby actually incurred, without regard to whether Licensee elects not to use the Pole or Poles after Make-ready Work has commenced. Licensee shall be obligated to pay Rocky Mountain Power for its costs

POLE ATTACHMENT AGREEMENT ROCKY MOUNTAIN POWER AND ZAYO GROUP

related to preparation of a Make-ready Work Cost Estimate, regardless of whether Licensee accepts or rejects the Cost Estimate. If requested by Rocky Mountain Power, Licensee shall submit pre-payment for the estimated Make-ready Work in accordance with UAR 746-345-3.C.7.

Rocky Mountain Power shall provide Licensee an estimated completion date for any Make-ready Work, taking into account the timeframes set by UAR 746-345-3, the overall scope of Licensee's project, the volume of Applications received from other licensees, as well as the availability of crews to perform the work. Licensee and Rocky Mountain Power shall negotiate solutions in good faith when the estimated time to perform the Make-ready Work does not meet Licensee's project requirements. At Licensee's option and upon approval from Rocky Mountain Power, Licensee may request either assistance with the work by Licensee or by qualified contractors hired by Licensee, payment of premium rates for Rocky Mountain Power's employees to be dedicated to perform work solely on Licensee's project, or similar measures designed to augment Rocky Mountain Power's capabilities. If Licensee chooses to employ self-build option as provided in UAR 746-345-3 C to complete the Make-ready Work, to ensure safety and reliability, the qualified contractor and the schedule must be approved by Rocky Mountain Power.

Rocky Mountain Power shall perform such Make-ready Work as may be required and Licensee shall pay Rocky Mountain Power for the Make-ready Work in accordance with the procedures outlined in UAR 746-345-3. Licensee shall pay the costs of all Make-ready Work undertaken by Rocky Mountain Power where such work is initiated as a result of the proposed installation of Attachments on any Poles without regard to whether Licensee elects not to use the Pole or Poles after Make-ready Work has commenced. Upon request, Rocky Mountain Power shall provide Licensee a statement of the actual material, hours, equipment costs, and any other associated costs for payment of Make-ready Work.

Section 3.02.01 Pole Replacement for Licensee's Benefit

Where an existing Pole is prematurely replaced by a new Pole for the benefit of Licensee, Licensee shall reimburse Rocky Mountain Power for all costs, including, but not limited to, the cost to replace the Pole, transfer and any required replacement of existing Rocky Mountain Power equipment, lower and haul of the existing Pole, and topping of the existing Pole when performed either as an accommodation to Licensee or as required by the NESC. Rocky Mountain Power shall remove and may retain or dispose of such Pole as the sole owner thereof. Any payments for Poles made by Licensee shall not entitle Licensee to ownership of any part of said Poles.

Section 3.02.02 Mid-span Poles

Any Poles erected by Licensee shall not interfere with, or be in-line with Rocky Mountain Power's Poles, and shall not create a structure conflict as defined in the NESC. If Licensee requires placement of a Pole in-line with any existing Poles ("i.e., a mid-span Pole"), Licensee shall notify Rocky Mountain Power of its need and Rocky Mountain Power shall determine the feasibility of such request and the request shall not be unreasonably denied. Licensee shall pay Rocky Mountain Power for all costs incurred by Rocky Mountain Power in installing such additional Poles. Rocky Mountain Power shall

POLE ATTACHMENT AGREEMENT ROCKY MOUNTAIN POWER AND ZAYO GROUP

have sole ownership of the mid-span Pole and Licensee shall pay rental fees to Rocky Mountain Power in accordance with Article IV.

Section 3.02.03 Pole Placement or Replacement for Joint Benefit of Rocky Mountain Power and Licensee

Where Rocky Mountain Power requires a new Pole for its utility purposes irrespective of Licensee's Attachment and Licensee requires a Pole with extra height or strength exceeding Rocky Mountain Power's requirements, Licensee shall pay to Rocky Mountain Power a sum equal to the difference between the cost, of erecting a Pole adequate to meet Rocky Mountain Power's needs, and the actual cost, of erecting a Pole adequate to meet both Parties' needs. Rocky Mountain Power shall bear the remainder of the cost of erecting such Pole. Each Party shall transfer its Equipment at its own cost.

Section 3.03 Licensee's Installation Responsibilities

Licensee shall complete the installation of its Attachments upon the Pole(s) covered by each approved Application within one hundred eighty (180) days following approval by Rocky Mountain Power. Licensee shall provide written notice to Rocky Mountain Power of its completion within five (5) Business Days of the actual installation.

In the event Licensee fails to complete installation of its Attachments within the prescribed time limit, the permission granted by Rocky Mountain Power to place Attachments upon the Pole or Poles shall automatically terminate and Licensee shall be required to reapply and receive permission to do so, all as prescribed in Section 3.01 as applicable to the initial Application. Licensee's failure to actually install its Equipment, after it has received approval from Rocky Mountain Power, shall not constitute entitlement for any refund or reduction of fees or rental charges incurred for its proposed Attachments.

Licensee shall have the right to install service drops prior to, but still subject to, approval by Rocky Mountain Power. However, when Licensee installs service drops, Licensee must follow all procedures applicable to Attachments generally, except that the Application pertaining to the service drop must be submitted to Rocky Mountain Power no later than five (5) Business Days after installation. Should Rocky Mountain Power deny permission to install the service drop, Licensee shall remove the service drop immediately. If Licensee has not removed its Attachments or fails to contact Rocky Mountain Power requesting a reasonable extension within the five (5) Business Day period, or in the case of emergencies, within the period specified by Rocky Mountain Power, Rocky Mountain Power may remove Licensee's Equipment at Licensee's sole risk and expense, and Licensee shall pay, upon demand, for all costs thereby incurred by Rocky Mountain Power.

Licensee need not submit Applications for additional Attachments within the permitted Attachment Space for mid-span service drops from permitted Pole Attachments, or service drop risers and associated Equipment attached directly to the Pole.

POLE ATTACHMENT AGREEMENT ROCKY MOUNTAIN POWER AND ZAYO GROUP

Section 3.04 Identification of Equipment

Licensee shall comply with UAR R746-345-4 regarding Attachment labeling, Licensee shall clearly mark Attachments with suitable identification visible from the ground that will not interfere with other facility identification, as mutually agreed to by both Parties.

Section 3.05 Conformance to Requirements and Specifications

Licensee shall, at its sole risk and expense, place and maintain its Equipment upon the Pole in conformity with the requirements and specifications of the NESC and such requirements and specifications as Rocky Mountain Power shall from time to time prescribe, including without limitation, the current Rocky Mountain Power Distribution Construction Standards (Exhibit C) and, as applicable, the current Rocky Mountain Power Engineering Handbook provisions (Exhibit D). In the event of any conflict between any of the requirements and specifications of the NESC, and those prescribed by Rocky Mountain Power, the more stringent requirements and specifications shall govern.

Licensee (including its employees and contractors) shall not enter Rocky Mountain Power's electric utility space for any purpose including making connections to the Rocky Mountain Power neutral. If Licensee requires grounding on an existing Pole where a grounding conductor does not exist, Licensee shall request that Rocky Mountain Power install grounding at the sole expense of Licensee. Licensee, its employees and its contractors, shall at all times exercise Licensee's rights and perform Licensee's responsibilities under the terms of this Agreement in a manner that treats all electric facilities of Rocky Mountain Power as energized at all times. Licensee shall indemnify, defend, and hold Rocky Mountain Power harmless from any liability of any sort derived from Licensee or Licensee's employees' or contractors' failure to abide by the terms of this paragraph.

Licensee shall have in place a facility Inspection program that ensures compliance with the requirements and specifications of this section, and Licensee shall provide Rocky Mountain Power with comprehensive documentation of Licensee's program upon request.

In the event that a streetlight photo-control socket is used to supply energy to Licensee's Equipment, the installation of which shall be performed only by a Rocky Mountain Power-approved qualified worker, Licensee shall: 1) assume responsibility for all costs associated with repair necessary due to such installation; 2) shall indemnify and hold Rocky Mountain Power harmless for any claims associated with a power outage caused by such installation; and 3) ensure that the light is working after installation, provided Licensee didn't previously notify Rocky Mountain Power of a malfunctioning of the light within two (2) Business Days of discovery of such malfunction and prior to installation of Licensee's Equipment.

Licensee shall not permit the transmission of its radio frequency signals to cause interference with or degradation of the transmissions, licensed or unlicensed radio frequencies, Equipment or utility operations of Rocky Mountain Power, other attaching entities, or devices lawfully operated by the public or other third-parties. Licensee shall, at its own expense, eliminate any such interference or degradation as soon as practicable after receipt of notice by Rocky Mountain Power or other third-parties, which notice may be made by telephone, facsimile or by notice.

POLE ATTACHMENT AGREEMENT ROCKY MOUNTAIN POWER AND ZAYO GROUP

Section 3.06 Nonconforming Equipment

If any Attachment is not placed and maintained in accordance with the requirements and specifications of Section 3.05, Rocky Mountain Power reserves the right to correct said condition upon Licensee's failure to do so. Such work shall be performed at Licensee's sole risk and expense. Rocky Mountain Power shall make commercially reasonable efforts to notify Licensee in writing prior to performing such work. However, if Rocky Mountain Power determines the conditions pose an immediate threat to the safety of utility workers or the public, interfere with the performance of Rocky Mountain Power's service obligations, or pose an immediate threat to the integrity of Rocky Mountain Power's Poles or Equipment, Rocky Mountain Power may perform such work, without prior notice, at the sole risk and expense of Licensee. As soon as practicable thereafter, Rocky Mountain Power shall notify Licensee in writing of the work performed. Licensee shall pay, upon demand, all costs thereby incurred by Rocky Mountain Power.

Section 3.07 Interference with Rocky Mountain Power's Equipment

If, in Rocky Mountain Power's judgment, Licensee's existing Attachments on any Pole interfere with Rocky Mountain Power's existing Equipment or prevent the placing of any additional Equipment by Rocky Mountain Power, Rocky Mountain Power shall notify Licensee in writing of rearrangements or transfers of Licensee's Attachment, Pole replacements or other changes required in order to continue to accommodate Licensee's Attachments. If appropriate, this notice shall include a Cost Estimate for any applicable Make-ready Work by Rocky Mountain Power to accommodate Licensee's continued Attachment.

If Licensee desires to continue to maintain its Attachments on a Pole where a Cost Estimate has been provided for accommodation work to be completed by Rocky Mountain Power, it shall return Rocky Mountain Power's notice of the Cost Estimate, signed by an authorized Licensee representative, within thirty (30) days. If Licensee does not accept the cost to accommodate its continued Attachment, Licensee shall remove its Attachments from the affected Pole or Poles within thirty (30) days from such notification by Rocky Mountain Power; provided, however, that Rocky Mountain Power in any emergency may require Licensee to remove its Attachments within the time required by the emergency. Licensee shall notify Rocky Mountain Power of its removal within five (5) Business Days of completion of the removal.

If Licensee has not removed its Attachments at the end of the thirty (30) day period, or in the case of emergencies, within the period specified by Rocky Mountain Power, Rocky Mountain Power may remove Licensee's Equipment at Licensee's sole risk and expense, and Licensee shall pay, upon demand, for all costs thereby incurred by Rocky Mountain Power.

Section 3.08 Expense of Situating Pole Attachments

Licensee shall place, maintain, rearrange, transfer, and remove its own Attachments at its own expense except as otherwise expressly provided hereunder. Nothing in this Agreement shall prohibit Licensee from seeking reimbursement for costs it incurs from third-party requests; however, all required work to be completed by Licensee must meet the timeframe prescribed by Rocky Mountain Power, without regard to third-party cost recovery negotiations.

POLE ATTACHMENT AGREEMENT ROCKY MOUNTAIN POWER AND ZAYO GROUP

Section 3.09 Vegetation Management

All vegetation management in connection with the initial placement of wires or other Attachment shall be undertaken entirely by the Party placing the wires or other Attachment at such Party's sole risk and expense. Unless agreed to otherwise, each Party shall be responsible for any and all vegetation management related to the wires or Attachment it owns. If Licensee fails to fulfill its obligations of this section, Rocky Mountain Power shall provide written notice to Licensee that if the issue is not resolved within thirty (30) days, Rocky Mountain Power shall perform the required remedy at Licensee's sole risk and expense.

Section 3.10 Third-party Consents, Permits, Licenses, or Grants

The right of access to Rocky Mountain Power's Poles granted by this Agreement does not include any right of access to the land upon which the Pole is situated nor does it include any right to cross the land from Pole-to-Pole with Licensee's Equipment and such access rights are specifically disclaimed. Licensee shall be solely responsible for obtaining from public authorities and private owners of real property and maintaining in effect any and all consents, permits, licenses or grants necessary for the lawful exercise by Licensee of the permission granted by Rocky Mountain Power hereunder. Licensee agrees to indemnify, defend and hold harmless Rocky Mountain Power against and from any and all third-party claims, demands, law suits, losses, costs and damages, including attorney's fees, to the extent arising from Licensee's failure, or alleged failure to have the requisite authority. Rocky Mountain Power, at any time, may require Licensee to submit written documentation of compliance with this section. Upon notice from Rocky Mountain Power to Licensee that necessary permission for the use of any Pole or Poles has expired, or has not been secured from property owners or public authorities, any permission granted covering the use of such Pole or Poles shall immediately terminate and Licensee shall remove its Equipment from the affected Pole or Poles within thirty (30) days of said notice, or within the period required by the property owners or public authorities, whichever is shorter. If Licensee has not removed its Equipment within said period, Rocky Mountain Power may remove Licensee's Equipment from such Poles without incurring any liability and Licensee shall, upon demand, pay Rocky Mountain Power all costs incurred by Rocky Mountain Power in the removal of Licensee's Equipment.

Section 3.11 Relocation of Attachments at Rocky Mountain Power's Option

Licensee shall at any time at its own sole risk and expense, upon notice from Rocky Mountain Power, relocate, replace, repair, or perform any other work in connection with the Attachments that may be required by Rocky Mountain Power, within thirty (30) days unless another timeframe is specified in writing by Rocky Mountain Power. Licensee shall provide written notification to Rocky Mountain Power within five (5) Business Days of its completion. Provided, however, that in cases of emergency or if Licensee does not complete required work by the end of the thirty (30) day period or other period specified by Rocky Mountain Power, Rocky Mountain Power may, without incurring any liability, except for Rocky Mountain Power's gross negligence or intentional misconduct, complete any work in connection with Licensee's Attachments that may be required, and Licensee shall reimburse Rocky Mountain Power for the entire expense thereby incurred.

Where Rocky Mountain Power replaces its Pole and cannot remove the replaced Pole due to Licensee's Attachment, Rocky Mountain Power shall remove the top of the Pole to allow

POLE ATTACHMENT AGREEMENT ROCKY MOUNTAIN POWER AND ZAYO GROUP

Licensee to relocate its Attachment to the new Pole, and Rocky Mountain Power shall make a return trip to remove the replaced Pole. Licensee shall reimburse Rocky Mountain Power for the cost incurred for the topping and return trip.

At Rocky Mountain Power's option, Rocky Mountain Power shall transfer Licensee's Attachment(s) when possible, at the listed rate in the Fee Schedule (Exhibit B) or for the actual cost of the transfer if a listed rate is not in place. If Equipment is needed for the transfer, Licensee shall supply the Equipment.

Section 3.12 Removal of Attachments by Licensee

Licensee may at any time remove its Attachments from any of the Poles and, in each case, Licensee shall immediately give Rocky Mountain Power written notice of such removal and removal shall occur within five (5) days of the notice. Application fees will apply to notices to remove Attachments pursuant to the Fee Schedule (Exhibit B). Removal of the Attachments from any Pole shall constitute a termination of Licensee's right to use such Pole. Licensee shall not be entitled to a refund of any rental on account of any such removal. When Licensee removes Attachments, the applicable Attachment count shall be reduced in the next annual billing cycle following Licensee's proper notice to Rocky Mountain Power of the removal. When Licensee performs maintenance to or removes or replaces its Attachment on a Rocky Mountain Power Pole, Licensee shall chemically treat all field drilled holes and plug any unused holes, including those resulting from removal of Attachment. If Licensee fails to adequately plug and treat such holes, Rocky Mountain Power may do so at Licensee's sole risk and expense.

If Licensee has not removed its Attachments within five (5) days of notice or fails to contact Rocky Mountain Power requesting a reasonable extension within five (5) Business Days, such Attachment(s) will be subject to unauthorized Attachment in accordance with Fee Schedule (Exhibit B).

Section 3.13 Damage to Equipment

Licensee shall exercise all necessary precautions to avoid causing damage to Rocky Mountain Power's Poles and Equipment and other Pole users' Equipment. Licensee shall assume responsibility for any and all loss from any such damage and shall reimburse Rocky Mountain Power for the entire expense incurred in making repairs.

Section 3.14 Inspections and Audits

Inspections. Rocky Mountain Power shall have the right to perform an Inspection (other than Audits) for each of Licensee's Attachments upon Rocky Mountain Power Poles at any time. Except for routine Periodic Safety Inspections and Audits, Rocky Mountain Power may charge Licensee for the expense of any such Inspections, including Inspections for Make-ready Work, Pre-Construction Inspections, Post-Construction (including any modifications or Pole transfers) Inspections, and any other Inspections requested by Licensee or deemed necessary by Rocky Mountain Power.

Audits. Rocky Mountain Power may conduct an Audit of Attachments made to its Poles no more frequently than once every five (5) years. Rocky Mountain Power shall give Licensee at least ninety (90) days prior notice of an initial meeting to plan the next Audit. At such meeting,

POLE ATTACHMENT AGREEMENT ROCKY MOUNTAIN POWER AND ZAYO GROUP

Rocky Mountain Power, Licensee and all other Pole attachers in attendance in person or by representative shall participate in, among other things, review of the predicted costs to perform an audit, the selection of an independent contractor for conducting the Audit, as well as the scheduling, scope, extent and reporting of the Audit results. Regardless of whether Licensee attends the Audit planning meeting or expresses an intention to participate in the Audit, Rocky Mountain Power shall notify Licensee at least sixty (60) days prior to the commencement of the Audit. Licensee shall advise Rocky Mountain Power if Licensee desires to participate in the Audit with Rocky Mountain Power not less than thirty (30) days prior to the scheduled date of such Audit. The data from the Audit shall be made available to Licensee and all other attachers on the Poles and used to update the Parties' records. Any Party shall make any objections to the Audit results within ninety (90) days of receipt of the Audit report or such objections are waived.

The cost of the Audit shall be included in the rental rate pursuant to the methodology approved by the Commission for such purposes. To the extent that during such a joint Audit, the respective Parties request items to be added to the Audit, beyond the scope predicated in the Rocky Mountain Power carrying charge, the additional costs for such items shall be the sole responsibility of the Party requesting them.

Section 3.15 Tax Liability

Licensee shall promptly pay any tax, fee, or charge that may be levied or assessed against Rocky Mountain Power's Poles or property resulting from use by Licensee. If Licensee should fail to pay any such tax or assessment on or before the date such tax or assessment becomes delinquent, Rocky Mountain Power, at its own option, may pay such tax on account of Licensee and Licensee shall, upon demand, reimburse Rocky Mountain Power for the full amount of tax and any penalties so paid. Nothing in this provision in any way limits either Party's rights to challenge such tax assessments.

ARTICLE IV. RENTAL PAYMENTS; FEES

Section 4.01 Rental Amount

For authorized Attachments covered under this Agreement, Licensee shall pay to Rocky Mountain Power, in advance, on an annual basis, a rental amount computed in accordance with UAR R746-345-5.A and Electric Service Schedule 4 (Exhibit A), on a billing cycle beginning July 1 of each year. The rental amount for each year shall be based on Rocky Mountain Power's tabulation of Licensee's Attachments situated upon Rocky Mountain Power's Poles and based upon Rocky Mountain Power's current records.

Consistent with the terms of this provision, the components of the rental rates, and the methodology employed to determine the rental rates are subject to UAR R746-345-5.A and may not be changed, modified or replaced except as allowed by applicable law.

The rental rate does not include the costs of Application processing, Inspections (other than Audits and Periodic Safety Inspections), Make-ready Work, and the costs related to unauthorized Attachments as addressed in Section 4.03. Charges for activities not included in the rental rate will be based on actual costs, including administrative costs, or flat rates specified in Exhibit B,

POLE ATTACHMENT AGREEMENT ROCKY MOUNTAIN POWER AND ZAYO GROUP

and will be charged in addition to the rental rate. Parties recognize that rates shall change consistent with approved changes to Electric Service Schedule 4 (Exhibit A) and Exhibit B.

Section 4.02 Attachment Space

Each permitted Attachment on a Pole shall constitute one Attachment Space for the calculation of annual contact rental (Exhibit A). If additional Attachments are placed within the same Attachment Space as a previously permitted Attachment, and are compliant with all requirements of this Agreement, no additional annual contact rental is applicable. If additional Attachments are permitted which are placed in the usable space of the Pole, but outside of the previously permitted Attachment Space, then an additional Attachment Space shall be added for calculation of annual contact rental. Permitted Attachments placed outside of the usable space on a Pole shall be excluded from the calculation of annual contact rental, including overlashed Attachments. Attachments, for the purpose of permitting, shall be limited to those wires, cables, wireless antennas, or rigid risers affixed to the Pole, including overlashed Attachments, and does not include related devices, apparatus, or auxiliary Equipment, such as non-rigid risers, fasteners, or brackets.

Section 4.03 Unauthorized Attachments

Licensee shall not make Attachments to Rocky Mountain Power's Poles without obtaining Rocky Mountain Power's written permission as provided for in this Agreement. Rocky Mountain Power may charge Licensee an unauthorized Attachment fee as shown on Exhibit B, upon the discovery of unauthorized Attachments belonging to Licensee. Back rent shall be charged for the lesser of 5 years or the period of unauthorized Attachment. The imposition of such charges shall be without prejudice to Rocky Mountain Power's right to utilize additional other remedies, including, but not limited to, the remedies available for default under Article VII of this Agreement and any remedies available under Commission rules. Licensee may avoid unauthorized Attachment fees, except back rent, if it self-discloses unpermitted Attachments and makes an Application for said Attachment pursuant to Section 3.01 prior to Rocky Mountain Power's discovery.

Section 4.04 Billing and Payments

Rocky Mountain Power shall send invoices to Licensee via regular U.S. Mail at the address(es) provided by Licensee in writing. Licensee shall pay all charges within forty-five (45) days of the invoice date. Late charges and interest shall be imposed on any delinquent amounts as specified in Section 4.05.

In the event Licensee disputes an invoice, Licensee shall provide written notice of the dispute to Rocky Mountain Power within forty-five (45) days of the date of the disputed invoice; otherwise Licensee shall forfeit its right to dispute the invoice, except as provided by Commission rule. Notice shall include an explanation of the basis for Licensee's dispute. Rocky Mountain Power reserves the right to impose interest as specified in Section 4.05 in the event the dispute is unfounded.

Licensee shall provide its accounts payable address(es) upon execution of this agreement and any future changes to the address(es) in writing sixty (60) days prior to the date of the change.

POLE ATTACHMENT AGREEMENT ROCKY MOUNTAIN POWER AND ZAYO GROUP

Copies of individual invoices may be requested in writing to be forwarded to an alternate address upon each written request.

Section 4.05 Interest on Late Payments

All amounts payable under the provisions of this Agreement shall, unless otherwise specified, be payable within forty-five (45) days of the invoice date. An interest charge at the lower of one and one-half percent (1.5%) per month or the maximum rate allowed by applicable law shall be assessed against all late payments.

ARTICLE V. INDEMNIFICATION; LIMITATION OF LIABILITY; WARRANTIES

Section 5.01 Indemnification/Release

To the fullest extent permitted by law, Licensee shall indemnify, protect, and hold harmless Rocky Mountain Power, its successors and assigns, and its directors, officers, employees and agents (collectively, the "Rocky Mountain Power Indemnified Parties") against and from any and all claims, demands, suits, losses, costs and damages of every kind and description, including attorneys' fees and/or litigation expenses, brought or made against or incurred by the Rocky Mountain Power Indemnified Parties resulting from, arising out of, or in any way connected with any act, omission, fault or negligence of Licensee, its employees, agents, representatives or contractors, their employees, agents or representatives in the performance or nonperformance of Licensee's obligations under this Agreement or in any way related to this Agreement except to the extent that such claim, demand, loss, cause of action, or costs arises from Rocky Mountain Power's gross negligence or intentional misconduct. Licensee shall also indemnify and release, protect and hold harmless the Rocky Mountain Power Indemnified Parties from and against any and all claims, demands, causes of action, costs (including attorneys' fees), or other liabilities arising from any interruption, discontinuance, or interference with Licensee's service to its customers which may be caused, or which may be claimed to have been caused, by any action of Rocky Mountain Power undertaken in furtherance of the purposes of this Agreement, including damages caused by Rocky Mountain Power's ordinary negligence. In addition, Licensee shall, upon demand, and at its own sole risk and expense, defend any and all suits, actions, or other legal proceedings which may be brought against Rocky Mountain Power Indemnified Parties, on any claim, demand, or cause of action arising from any interruption, discontinuance, or interference with Rocky Mountain Power's service to Rocky Mountain Power's customers which may be caused, or which may be claimed to have been caused, by any action of Licensee. To the extent Licensee shall be found to have caused such interruption, discontinuance or interference, Licensee shall pay and satisfy any judgment or decree which may be rendered against Rocky Mountain Power Indemnified Parties, in any such suit, action, or other legal proceeding; and further, Licensee shall reimburse Rocky Mountain Power for any and all legal expenses, including attorneys' fees, incurred in connection therewith, including appeals thereof. Licensee hereby releases Rocky Mountain Power from any liability for damage to Equipment, or for any interruption, discontinuance or interference with Licensee's service to its customers, caused by or resulting from Rocky Mountain Power's actions or inaction, including damages caused by Rocky Mountain Power's ordinary negligence.

POLE ATTACHMENT AGREEMENT ROCKY MOUNTAIN POWER AND ZAYO GROUP

Section 5.02 Warranty

Rocky Mountain Power warrants that its work in constructing and maintaining the Poles covered by this Agreement shall be consistent with prudent utility practices. **ROCKY MOUNTAIN POWER DISCLAIMS ALL OTHER WARRANTIES, EXPRESS OR IMPLIED, INCLUDING BUT NOT LIMITED TO THE WARRANTY OF MERCHANTABILITY, FITNESS FOR PARTICULAR PURPOSE, AND SIMILAR WARRANTIES.** Under no circumstances shall Rocky Mountain Power be liable for economic losses, costs or damages, including but not limited to special, indirect, incidental, punitive, exemplary or consequential damages.

ARTICLE VI. INSURANCE, SECURITY AND CREDIT REQUIREMENTS

Section 6.01 Insurance

Without limiting any liabilities or any other obligations of Licensee, Licensee shall secure and continuously carry during the term of this Agreement with insurers having an A.M. Best Insurance Reports rating of A-:VII or better the following insurance coverage:

- a. Workers' Compensation. Licensee shall comply with all applicable Workers' Compensation Laws and shall furnish proof thereof satisfactory to Rocky Mountain Power prior to commencing Work.

All Workers' Compensation policies shall contain provisions that the insurance companies will have no right of recovery or subrogation against Rocky Mountain Power, its parent, divisions, affiliates, subsidiary companies, co-lessees, or co-venturers, agents, directors, officers, employees, servants, and insurers, it being the intention of the Parties that the insurance as effected shall protect all Parties.

- b. Employers' Liability. Insurance with a minimum single limit of \$1,000,000 each accident, \$1,000,000 by disease-each employee, and \$1,000,000 by disease-policy limit.
- c. Commercial General Liability. Licensee shall maintain commercial general liability insurance on the most recently approved ISO policy, or its equivalent, written on an occurrence basis, with minimum limits of \$1,000,000 each occurrence/ \$2,000,000 general aggregate for bodily injury and property damage, including the following coverages:
 - a. Premises and operations coverage
 - b. Independent contractor's coverage
 - c. Contractual liability
 - d. Broad form property damage liability
 - e. Sudden and accidental pollution liability, if appropriate
- d. Business Automobile Liability. Licensee shall maintain business automobile liability insurance on the most recently approved ISO policy, or its equivalent, with a minimum combined single limit of \$1,000,000 for bodily injury and property damage with respect to Licensee's vehicles whether owned, hired or non-owned, assigned to or used in the performance of the Work.

POLE ATTACHMENT AGREEMENT ROCKY MOUNTAIN POWER AND ZAYO GROUP

- e. Umbrella Liability. Licensee shall maintain umbrella or excess liability insurance with minimum limits of \$5,000,000 each occurrence/\$5,000,000 aggregate where applicable, providing following form coverage in excess of the coverages and limits required in Employers' Liability insurance, Commercial General Liability insurance and Business Automobile Liability insurance above. Licensee shall notify Rocky Mountain Power, if at any time their full umbrella limit is not available during the term of this Agreement, and will purchase additional limits, if requested by Rocky Mountain Power.

Section 6.02 Additional Insurance Requirements

The following additional requirements apply to coverage specified in Section 6.01:

Commercial general liability and business automobile insurance policies shall include provisions or endorsements that:

- i) name Rocky Mountain Power, its officers, directors, agents, and employees as additional insureds.
- ii) such insurance is primary insurance with respect to the interests of Rocky Mountain Power and that any other insurance maintained by Rocky Mountain Power is excess and not contributory insurance with the insurance required herein;
- iii) such insurance shall provide cross liability or a severability of interest clause.

All policies shall include provisions or endorsements that provide:

- i) limits of coverage in each of these required policies shall not be reduced without written notification to Rocky Mountain Power prior to the effective date of such change, and
- ii) no policy shall be cancelled without prior written notice to Rocky Mountain Power and to all other insured Parties of no less than (a) ten (10) days if cancelled for nonpayment of premium, or (b) thirty (30) days if cancelled for any other reason.

All required insurance policies shall not contain any provisions prohibiting waivers of subrogation. Unless prohibited by applicable law, all required insurance policies shall contain provisions that the insurer will have no right of recovery or subrogation against Rocky Mountain Power, its parent, divisions, affiliates, subsidiary companies, co-lessees, or co-venturers, agents directors, officers, employees, servants, and insurers, it being the intention of the Parties that the insurance as effected shall protect all Parties.

Prior to installation of Equipment as permitted under this Agreement, and prior to expiration of each policy throughout the term of this Agreement, Licensee shall provide certificates of insurance evidencing current insurance coverage, and confirming compliance with the requirements stated in this article.

Section 6.03 Security

Rocky Mountain Power may require Licensee to furnish Security if (a) the total number of Estimated Attachments is greater than fifty (50) and Licensee does not make the affirmation specified in Section 6.04 (f); (b) the total number of Licensee's actual Attachments at any time exceeds fifty (50) unless Licensee provides to Rocky Mountain Power an affirmation as set forth

POLE ATTACHMENT AGREEMENT ROCKY MOUNTAIN POWER AND ZAYO GROUP

in Section 6.04(f); or (c) Licensee experiences a Material Adverse Change. If Licensee is required to post Security pursuant to this Section 6.03, and at any time the number of Attachments exceeds one hundred twenty percent (120%) of the Estimated Attachments, Licensee shall continue to provide, no less frequently than annually, increased Security based on the number of actual Attachments. Rocky Mountain Power may draw upon such Security to satisfy Licensee's obligations under this Agreement, and Licensee shall replenish such Security within sixty (60) days.

Section 6.04 Credit Requirements

Licensee need not post Security under Section 6.03 for the benefit of Rocky Mountain Power as long as Licensee warrants, and continues during the term of this Agreement, to comply with all of the following representations, warranties and obligations:

- a. Neither Licensee nor any of its principal equity owners is or has within the past two (2) years been the debtor in any bankruptcy proceeding, is unable to pay its bills in the ordinary course of its business, or is the subject of any legal or regulatory action, the result of which could reasonably be expected to impair Licensee's performance under this Agreement;
- b. Licensee has not at any time defaulted in any of its payment obligations under any other agreement with Rocky Mountain Power;
- c. Licensee is not in material default under any of its other agreements and is current on all of its financial obligations;
- d. Licensee shall provide to Rocky Mountain Power and shall at all times maintain an official Certificate of Existence as issued by the Utah Secretary of State;
- e. Licensee shall provide to Rocky Mountain Power and shall at all times maintain a valid business license, issued by the proper local, state and/or Federal authority.
- f. Applicable only to a Licensee with Estimated Attachments greater than fifty (50) Licensee meets the Credit Requirements, and will, within thirty (30) days of a request by Rocky Mountain Power, provide copies of its most recent annual and quarterly financial statements.

Licensee hereby declares (Licensee initial one only):

PS Licensee affirms and adopts all warranties in this Section 6.04, and therefore is not required to post the security specified in Section 6.03.

_____ Licensee does not affirm and adopt all warranties in this Section 6.04, and therefore Licensee elects to post the security specified in Section 6.03.

POLE ATTACHMENT AGREEMENT ROCKY MOUNTAIN POWER AND ZAYO GROUP

ARTICLE VII. TERM, DEFAULT AND TERMINATION

Section 7.01 Term and Termination

Unless terminated sooner as provided herein, this Agreement shall remain in full force and effect unless and until it is terminated by either Party upon ninety (90) days written notice to the other Party. Licensee shall remove its Equipment from Poles within said ninety (90) day notice period. Should Licensee fail to remove its Equipment within such period, Rocky Mountain Power may remove and dispose of Licensee's Equipment at Licensee's sole risk and expense. On the date of termination specified in such notice, all rights and privileges of Licensee hereunder shall cease; provided however that Licensee shall not be released from any liability hereunder, which may accrue or be accruing or which arises out of any claim that may have accrued or may be accruing at the time of termination.

Rocky Mountain Power reserves the right to terminate Licensee's permit to use any particular Pole or Poles at any time upon thirty (30) days written notice to Licensee and Licensee shall remove its Equipment from Rocky Mountain Power's Pole or Poles within the thirty (30) day period and provide written notice to Rocky Mountain Power upon its completion.

Section 7.02 Default

The following shall constitute a default hereunder if not cured as provided in Section 7.03: (a) any material breach of this Agreement, including, without limitation, the failure to comply with Section 6.03 and Section 6.04; (b) the appointment of a receiver to take possession of all of the assets of Licensee; (c) a general assignment for benefit of creditors; (d) any action taken or suffered by Licensee under any insolvency or bankruptcy act.

Section 7.03 Notice of Default/Cure Period

The non-defaulting Party shall provide written notice of the default to the other and the defaulting Party shall have thirty (30) days from receipt of said notice to cure the default. Provided however, in such cases where a default cannot be cured within the thirty (30) day period by the exercise of diligent, commercially reasonable effort, the defaulting Party shall have an additional sixty (60) days to cure the default for a total of ninety (90) days after the Party not in default provides its notice of default.

Section 7.04 Remedies for Default

The non-defaulting Party may utilize any and all remedies available to it at law and in equity in the event the defaulting Party fails to cure a default within the time period set forth above. Such remedies may include, without limitation: (a) refusal to authorize any additional Attachments until the default is cured; (b) termination, in whole or in part, of this Agreement; (c) withhold amounts due to the defaulting Party from non-defaulting Party pursuant to this Agreement or another agreement; and (d) cure the default, if Licensee is the defaulting Party, at Licensee's sole cost and expense.

POLE ATTACHMENT AGREEMENT ROCKY MOUNTAIN POWER AND ZAYO GROUP

ARTICLE VIII. GENERAL PROVISIONS

Section 8.01 Entire Agreement

This Agreement constitutes the entire Agreement of the Parties and supersedes and terminates any prior agreements relating to the subject matter hereof. Any amendments hereto shall be in writing and signed by the Parties.

Section 8.02 Choice of Law/Venue

This Agreement and performance hereunder shall be construed, interpreted, regulated and enforced pursuant to the laws of Utah. The state and federal courts within Salt Lake County, Utah shall constitute the sole proper venue for resolution hereunder and the Parties agree to submit to such jurisdiction.

Section 8.03 Changes in Law

The Parties agree to negotiate in good faith any changes to this Agreement necessitated to conform to applicable law.

Section 8.04 Severability

If any provision or part of this Agreement is or becomes invalid under any applicable statute, regulation, or law and such invalidity does not materially alter the essence of this Agreement with respect to either Party, the invalidity shall not render this entire Agreement unenforceable and such provision or part shall be deemed void.

Section 8.05 Encumbrances

Licensee shall prevent any and all liens or other encumbrances from attaching, as result of Licensee's activities hereunder, to Rocky Mountain Power's property.

Section 8.06 Headings and Exhibits

The captions and headings herein are for convenience in reference only and not for interpretation purposes. All exhibits referred to herein and recitals are incorporated by reference.

Section 8.07 Force Majeure

Except for the late payment of monies due under this Agreement, neither Party shall be deemed in default hereunder for any delay or failure in the performance of its obligations to the extent that such inability shall be due to causes beyond the control of the Party seeking to invoke this provision, including, but not limited to, the following: (a) the operation and effect of any rules, regulations and orders promulgated by any Commission, municipality, or governmental agency of the United States, or subdivision thereof; (b) restraining order, injunction or similar decree of any court; (c) war; (d) earthquake, fire or flood; (e) act of God; (f) civil disturbance; (g) strikes or boycotts; or (h) major equipment breakdown or failure. Should any of the foregoing occur for a continuous duration lasting longer than one month, the contact rental rate shall be applied to only those Attachments where Rocky Mountain Power is able to provide Poles and to those Poles where Licensee is able to attach. The Party claiming Force Majeure under this provision shall provide prompt written notice to the other Party and shall make every reasonable attempt to mitigate or remedy the cause thereof as diligently and expeditiously as possible. Time periods for performance obligations of Parties herein shall be extended for the period during which Force

POLE ATTACHMENT AGREEMENT ROCKY MOUNTAIN POWER AND ZAYO GROUP

Majeure was in effect. In the event that a Force Majeure event occurs, and Licensee does not reinstall Attachments at pre-event levels within six (6) months of the beginning of the event, the Permit for each Attachment which is not reinstalled shall terminate.

Section 8.08 Assignments

Licensee shall not voluntarily or involuntarily assign, transfer, sublease or sublet this Agreement, in whole or in part, or any right, privilege or obligation hereunder, without Rocky Mountain Power's prior written consent, at which time Rocky Mountain Power may require that the proposed assignee or successor enter into a new agreement or other reasonable conditions; provided that Licensee may assign this agreement to an affiliate without consent as long as prior written notice is provided. Approval of assignment may require Application to remove from each Pole by the Assignor and an Application to attach to each Pole by Assignee, and payment of associated fees, if the record of Attachments from either attaching Party is inconsistent with Rocky Mountain Power's records.

Section 8.09 Waiver

Failure by either Party to enforce any of the terms or provisions of this Agreement shall not be construed as a waiver hereunder.

Section 8.10 Time is of Essence

Time is of essence with respect to every term and provision of this Agreement.

Section 8.11 No Partnership

Nothing herein shall be construed to create a partnership, trust, joint venture, or association between the Parties.

Section 8.12 No Third-party Beneficiaries

This Agreement shall not be construed for the benefit of any third-party, including without limitation, customers of either Party.

Section 8.13 Attorneys' Fees

If either Party files any action or brings any court proceeding against the other arising from or related to this Agreement, the prevailing Party shall be entitled to recover, in addition to any judgment or decree for costs, such reasonable attorneys' fees as it may have incurred in such suit, action, or other legal proceeding, together with other reasonable litigation expenses.

Section 8.14 Waiver of Jury Trial

TO THE FULLEST EXTENT PERMITTED BY LAW, EACH OF THE PARTIES HERETO WAIVES ANY RIGHT IT MAY HAVE TO A TRIAL BY JURY IN RESPECT OF LITIGATION DIRECTLY OR INDIRECTLY ARISING OUT OF, UNDER OR IN CONNECTION WITH THIS AGREEMENT. EACH PARTY FURTHER WAIVES ANY RIGHT TO CONSOLIDATE ANY ACTION IN WHICH A JURY TRIAL HAS BEEN WAIVED WITH ANY OTHER ACTION IN WHICH A JURY TRIAL CANNOT BE OR HAS NOT BEEN WAIVED.

POLE ATTACHMENT AGREEMENT ROCKY MOUNTAIN POWER AND ZAYO GROUP

Section 8.15 Agreement Notices

Except as otherwise provided herein, any notice regarding this Agreement hereunder shall be in writing, shall be addressed to the Party to be notified at the address set forth below or at such other address as a Party may designate for itself from time to time by written notice, and shall be transmitted by United States mail, by regularly scheduled overnight delivery, or by personal delivery:

Rocky Mountain Power:
Joint Use Administration-Contracts
825 NE Multnomah St., Suite 1700
Portland, Oregon 97232

Zayo Group, LLC
400 Centennial Parkway
Suite 200
Louisville, CO 80027

Section 8.16 Operational Notice

All notices regarding permitting and other communications regarding day-to-day operations shall be submitted by the Parties via an ENS if designated by Rocky Mountain Power, via e-mail at the addresses set forth below or at such other address as a Party may designate for itself from time to time by written notice.

Rocky Mountain Power:
jointuse@pacificorp.com

Zayo Group, LLC
Jeff.seglen@zayo.com
(208) 954-3018

POLE ATTACHMENT AGREEMENT ROCKY MOUNTAIN POWER AND ZAYO GROUP

IN WITNESS WHEREOF, the Parties have caused this Agreement to be executed by their duly authorized officers as of the date first herein written.

LICENSEE
ZAYO GROUP, LLC

PACIFICORP, doing business as

ROCKY MOUNTAIN POWER



Signed
Gregg Strumberger

Printed
General Counsel, ZFTI

Title
10/31/12

Date Signed

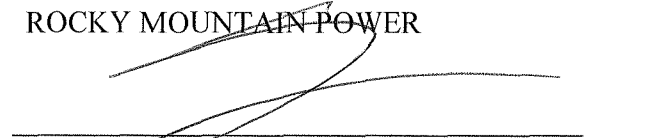

Signed
STUART KELLY

Printed
MD, in Construction Support Svcs.

Title
11/14/12

Date Signed



ROCKY MOUNTAIN POWER
ELECTRIC SERVICE SCHEDULE NO. 4

STATE OF UTAH

Pole Attachments

AVAILABILITY: To public utilities, wireless providers, cable television companies, communications companies, or other entities that provide information or telecommunications services or any other services whose operation requires that cables, wires, and other appurtenances be placed on Company utility poles. This Schedule shall be available only upon the following three conditions:

1. The execution of a Pole Attachment Agreement between an "attaching entity" as defined by Utah Admin. Code § R746-345-2 and the Company for permission to place equipment on the Company's poles; or, in the event that such an agreement has not been reached, the attaching entity is subject to the provisions of the standard Attachment Agreement approved by the Utah Public Service Commission ("Standard Agreement").
2. The approval by the Company of the attaching entity's application, as required under the agreement between the Company and the attaching entity, for permission to place equipment on Company poles.
3. The availability of utility poles located on the Company's interconnected system in the state of Utah, which are of sufficient size and capacity to accommodate the equipment to be installed in accordance with the National Electric Safety Code, the applicable pole attachment agreement and applicable Utah Administrative Code provisions.

APPLICATION: The rate specified in this Electric Service Schedule shall apply to all Company-owned poles.

(continued)



ELECTRIC SERVICE SCHEDULE NO. 4 - Continued

ANNUAL CHARGE: For each Company pole on which the attaching entity has placed an attachment, \$7.02 per foot of space used by the attaching entity. "Space used" is determined under the provisions of Utah Admin. Code § R746-345-5.A.3.

TERMS, CONDITIONS, LIABILITIES: The terms, conditions, and liabilities for service under this Schedule shall be those specified in the applicable pole attachment agreement between the Company and the attaching entity. The annual charge rate specified by the agreement shall be in accordance with the rate specified in this Schedule and shall be subject to periodic adjustment in accordance with the applicable agreement and the rules established by the Public Service Commission of Utah and subject to its approval.

ELECTRIC SERVICE REGULATIONS: Service under this Schedule will be in accordance with the terms of the Pole Attachment Agreement or the Standard Agreement between the Company and the attaching entity. The Electric Service Regulations of the Company on file with and approved by the Public Service Commission of Utah, including future applicable amendments, will be considered as forming a part of and incorporated in said Agreement. In case of any conflict between any of the provisions of the Pole Attachment Agreement or Standard Agreement, this Rate Schedule, and the Electric Service Regulations, the provisions of this Rate Schedule will take precedence followed by the provisions of the Pole Attachment Agreement or the Standard Agreement, whichever is applicable.

Exhibit B

Page 1 of 2

Fee Schedule for non-recurring charges

1. Application Processing Fee (ENS or written) \$26.65 + \$4.00 per Pole

2. Inspections

In instances when PacifiCorp has sufficient electronic Pole Attachment data existing in its system of record, PacifiCorp may elect to perform a desktop Inspection, which is defined as an Inspection performed using only existing electronic data, maps and pictures. There are no Inspection fees associated to a desktop Inspection.

In instances when PacifiCorp does not have sufficient electronic data to perform a desktop Inspection or the desktop Inspection results in findings that require a field visit, the following Inspection fees apply:

2(a) Pre-Construction Inspection Fees - these fees are based upon Applications by various entities that wish to attach a cable, or other device, to PacifiCorp's facilities and also occurs prior to when a Licensee wishes to place new cables and/or additional equipment. All Pre-Construction and Post-Construction Inspections are broken into three levels of time usage and complexity.

Level 1 (Visual Inspection) \$31.30 first Pole; \$17.65 each Pole thereafter

Level 1 Inspections are defined as a "drive by" that does not require the inspector to exit the vehicle and are intended to identify that clearances and strength of the structure are visibly verifiable. These Inspections are typically performed when the Licensee has provided all required information given the type of request on the Application form.

Level 2 (Measured Inspection) \$41.20 first Pole; \$30.40 each Pole thereafter

Level 2 Inspections are most commonly performed when the Poles do not appear to have proper clearance to accommodate the newly proposed Attachment or when the Licensee has failed to provide all required information given the type of request on the Application form.

Level 3 (Pole Analysis Inspection) \$88.55 first Pole; \$75.90 each Pole thereafter

Level 3 Inspections are most commonly performed when the Poles do not appear to have proper strength to accommodate the newly proposed Attachment or when the Licensee has failed to provide all required information given the type of request on the Application form. This level of inspection is highly common on requests for use of transmission Poles.

PacifiCorp will not charge Pre-Construction Inspection Fees for an Application to remove Attachments.

Exhibit B

Page 2 of 2

2(b) Post-Construction Inspection Fees - these Inspections are completed after a Pre-Construction Inspection has been approved, and the installation by the original requesting company has been completed.

Level 4 (Visual Inspection) \$31.30 first Pole; \$17.65 each Pole thereafter
Level 4 Inspections are defined as a “drive by” that does not require the inspector to exit the vehicle and are intended to identify that the Licensee has complied with the engineering data provided in the Application form. This level of inspection will be used for all removals of Attachments, unless the removal has resulted in damage to the Pole in which case additional fees to assess the damage may apply.

Level 5 (Measured Inspection) \$41.20 first Pole; \$30.40 each Pole thereafter
Level 5 Inspections are most commonly performed when it appears that the Licensee has failed to perform construction in accordance with the specifications on their Application form, has created a NESC violation or has attached to the Pole prior to receiving approval from PacifiCorp.

Level 6 (Pole Analysis Inspection) \$88.55 first Pole; \$75.90 each Pole thereafter
Level 6 Inspections are most commonly performed when it appears that the Licensee has attached to a Pole prior to receiving approval from PacifiCorp and appears to have compromised the integrity of the existing structure. This level of Inspection is highly common on requests for use of transmission Poles.

3. Unauthorized Attachment Charge

\$100.00 + Back Rent, per Pole

Back Rent shall consist of 5 years of rent at the current rental rate.

4. Topping Fee

A charge of \$64 per Pole will be assessed, where PacifiCorp completes a Pole replacement for the benefit of the Licensee and the transfer of Attachments on the Pole requires removal of the top of the Pole to be completed by PacifiCorp.

5. Return Trip Fee

A charge of \$255 per Pole will be assessed, where PacifiCorp completes a Pole replacement for the benefit of the Licensee and the removal of the replaced Pole cannot be completed at the time of construction due to the Licensee’s Attachment or other attachers’ existing Attachment(s) on the Pole necessitating PacifiCorp to return to the site once the necessary transfer is complete. Removal of the Pole is not included in this charge.

This Fee Schedule is subject to change and may be modified once a year by PacifiCorp upon sixty (60) days written notice to Licensee.

POLE ATTACHMENT AGREEMENT ROCKY MOUNTAIN POWER AND ZAYO GROUP

Exhibit C

Page 0 of 38

Rocky Mountain Power's Distribution Construction Standards

This Page is left intentionally blank

EU - Joint Use

Table of Contents

Information Standards

<u>Standard</u>	<u>Title</u>	<u>Revision Date</u>
EU 001	Joint Use—General Information	10 Nov 98
EU 101	Joint Use—Pole Space Allocation	1 Oct 10
EU 211	Joint Use—Climbing Space Through Communication Circuits	31 May 93
EU 221	Joint Use—Clearances, Communication to Supply Circuits	8 Nov 07
EU 231	Joint Use—Clearances, Communication Above Ground, Roadway or Water	(reverted to) 26 Oct 98
EU 241	Joint Use—Clearances, Communication Equipment to Risers	(reverted to) 19 Nov 97
EU 251	Joint Use—Clearances, Communication Equipment to Transformers	(reverted to) 26 Dec 97
EU 261	Joint Use—Clearances, Communication Equipment to Street Lights	(reverted to) 8 May 95
EU 271	Joint Use—Clearances, Communication Equipment to Street Lights—California	2 Sept 97
EU 281	Joint Use—Clearances, Low Voltage Service Drops	31 May 93
EU 401	Joint Use—CATV on Poles	1 Oct 10

EU

Table of Contents



Distribution Construction Standards

This page is left blank intentionally.

Joint Use—General Information

A. Scope

Joint use agreements with other utilities include standards covering the attachments involved. This section contains drawings covering joint use of poles by supply and communications circuits and equipment. These drawings conform with the applicable requirements of joint pole practices for supply and communications circuits: National Electrical Safety Code, ANSI C2-1997 (NESC); California Public Utility Commission General Order No. 95 (G.O. 95); and other state and local requirements.

B. General

The drawings in this section specify the clearances required and the typical arrangement of attachments.



Questions concerning conflicts or impaired clearances between supply circuits and communications circuits, including community antenna TV cables, which are not adequately covered by the scope or detail of this section, shall be referred to the area engineer.

These standards apply to all other utilities and other entities who own facilities which contact or are supported by equipment owned by PacifiCorp, including attachments not covered by joint use agreements.

Any trolley circuits attached to company-owned power poles will require special joint use agreements and drawings showing clearances. Trolley circuit attachments will require distribution engineering approval on a case-by-case basis.

Over-lashing of communication cables is an acceptable practice and will follow the same policy as any other attachment request. The application will be reviewed by PacifiCorp and the party being over-lashed, to determine any upgrades that may be required. The requesting party, the party that is being over-lashed, and PacifiCorp will agree to payment of the cost of any needed upgrades and the attachment fees.

The addition of the new cable will place additional loading requirements on poles and down guys and will impact the sag of the existing cable. These items will need to be reviewed to see if pole change-outs or guy replacements will be necessary.

<p>Distribution Construction Standard © 1998 by PacifiCorp. All rights reserved.</p>	<p>Joint Use General Information</p>	<p> PACIFICORP PACIFIC POWER UTAH POWER</p>	
<p>Engineer (S. Waddoups):  Stds Team Leader (D. Jones): </p>		<p>10 Nov 98</p>	<p>EU 001 Page 1 of 2</p>

EU 001

This page is left blank intentionally.



EU 001
Page 2 of 2

10 Nov 98

**Joint Use
General Information**

**Distribution
Construction Standard**

© 1998 by PacifiCorp. All rights reserved.

Engineer (S. Waddoups):

Stds Team Leader (D. Jones):

Joint Use—Pole Space Allocation

A. Scope

This standard provides information regarding the allocation of space on joint use poles for attachment of telephone, cable TV, and PacifiCorp facilities.

B. General

1. Compliance with Safety Codes and Rules

It is intended that all construction will meet or exceed the requirements of the latest edition of the National Electrical Safety Code (NESC). All work will be performed in a safe manner which complies with the rules of the NESC, the Occupational Safety and Health Administration (OSHA) and the rules of any state agencies having jurisdiction.

2. Communication Includes Telephone and Cable TV

The term "communication" is considered to include both telephone and cable TV. This is how the term is used by the NESC.

3. Available Pole Space

The setting depth of a pole in normal soil is approximately 10% of the pole length plus 2 feet. Thus a 40-foot pole will be set 6 feet into the ground with 34 feet remaining above ground; and a 45-foot pole will be set 6 1/2 feet deep with 38 1/2 feet above ground.

4. Joint Use Agreements

Some of the joint use agreements do not match all conditions set forth in the EU section of the distribution construction standards. A specific joint use agreement may spell out a different method of sharing costs of taller poles. In that case, the agreement takes precedence over this standard.

5. Bonding of Communication or Cable Equipment to Ground

When a pole ground is required by the communication utility and does not exist on the pole, the communication utility shall request the installation of a pole ground by PacifiCorp. This allows PacifiCorp to ground the neutral conductor attached to the pole. The communication company shall pay for all expenses incurred. At no time shall the communication utility personnel be in PacifiCorp's pole space.

6. Guying and Anchoring

The communication utility shall not attach their guy wires to PacifiCorp's anchors unless explicit written permission is given for each specific location. Anchor rod auxiliary eyes are not permitted on PacifiCorp anchors. Additionally, all guy wires installed on PacifiCorp anchors to support communication utility's equipment or cable shall be insulated as defined by Rule 279A2a of the NESC and in accordance with PacifiCorp standard practice. This practice meets code and also prevents galvanic corrosion of anchors. The insulator shall meet NESC flashover and strength requirements. If, by written permission, PacifiCorp allows the guy wire to be bonded at the pole, an insulator is still required that meets NESC strength requirements as stated in NESC Rules 279A3 and 279A1c.

<p>Distribution Construction Standard © 2010 by PacifiCorp. All rights reserved.</p>	<p>Joint Use Pole Space Allocation</p>	
<p>Engineer (D. Asgharian): <i>DDA</i> Standards Manager (G. Lyons): <i>GL</i></p>		

EU 101

All guy wires attached to the communication utility's own anchors shall meet NESC requirements.

Slack span installations and unguyed dead-end pole installations by communications licensee companies are not allowed on PacifiCorp-owned poles unless:

- a) The communications company provides a complete engineering design and review, signed and stamped by a licensed Professional Engineer.
- b) The engineering review shall be included in the application, with all tensions, strengths, angles and calculations associated with the proposed slack span or unguyed deadend installation, and:
- c) Receipt of the Professional Engineer's design and review is acknowledged in writing by PacifiCorp.

7. Replacing an existing pole

When PacifiCorp has need to replace an existing pole with joint use attachments and the attachment cannot immediately be transferred directly to the new pole, an alternative method of attachment may be used to reduce crew and traveling time. The following criteria must be satisfied prior to such action:

1. The pole is positioned close enough to allow attachment by this method.
2. The condition of the old pole section will maintain the integrity of the attachments.
3. No other issues are apparent that sacrifice proper clearances, safety, or working conditions.

This method of attachment should be considered temporary, and affected joint use utilities must remove their facilities within a reasonable time frame. Additionally, the last joint use utility to work on the structure must remove and dispose of the old section of the pole and DA bolts.

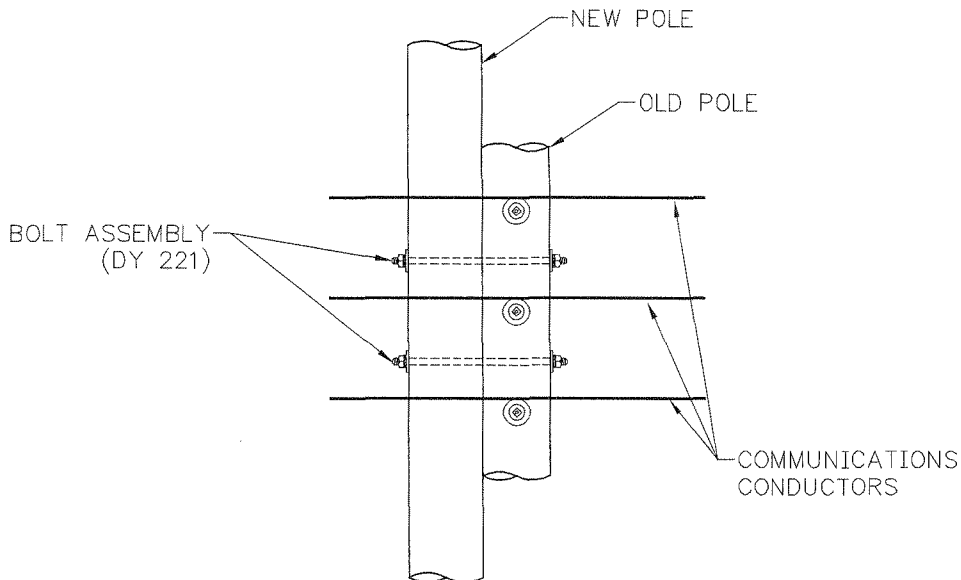

Figure 1—Pole Replacement with Existing Communications Conductors



C. Allocation of Pole Space

1. Separation Space - Permitted Uses

- a) There shall be a minimum of 40 inches of clearance between the surface (not the center) of any supply system conductors or equipment (including support hardware and washers) and any communications system conductors or equipment (including support hardware and washers).
- b) Communication equipment is not permitted to be mounted in the 40-inch separation space.
- c) Street lighting fixtures may be installed in the separation space when necessary to meet mounting height requirements provided that such installations are in accordance with the NESC and other applicable codes. For details, see EU 261. In California, see EU 271.

2. 40-Foot Basic Pole

The allocation of space and the usual points of attachments for telephone, TV cable, and electric facilities depends on the length of the "basic pole". In some areas, the basic pole is 40 feet in length (about 34 feet above ground). Figure 1 shows the space allocations and the usual points of attachment for a 40-foot joint use pole.

<p>Distribution Construction Standard © 2010 by PacifiCorp. All rights reserved.</p>	<p style="text-align: center;">Joint Use Pole Space Allocation</p>	 <p style="text-align: center; font-size: small;">A MIDAMERICAN ENERGY HOLDINGS COMPANY</p>	
<p>Engineer (D. Asgharian): <i>DDA</i> Standards Manager (G. Lyons): <i>GL</i></p>		<p>1 Oct 10</p>	<p>EU 101 Page 3 of 6</p>

EU 101

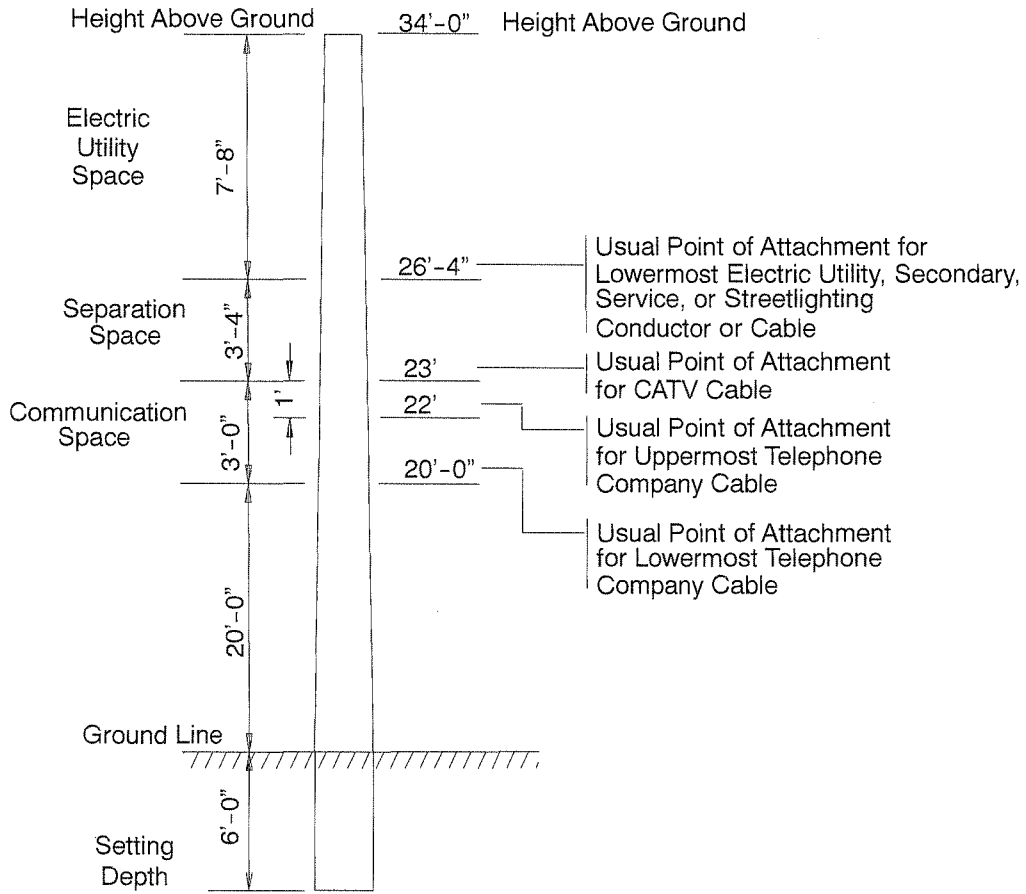

Figure 1 - Space Allocation on 40Foot Basic Joint Use Pole



Joint Use Pole Space Allocation

Distribution Construction Standard

© 2010 by PacifiCorp. All rights reserved.

Engineer (D. Asgharian): *DDA*
 Standards Manager (G. Lyons): *GL*

3. Poles Taller Than the 40-Foot Basic Pole

The company requiring extra pole height pays the extra cost and gets to use the extra height, less the 10% used by the deeper pole hole.

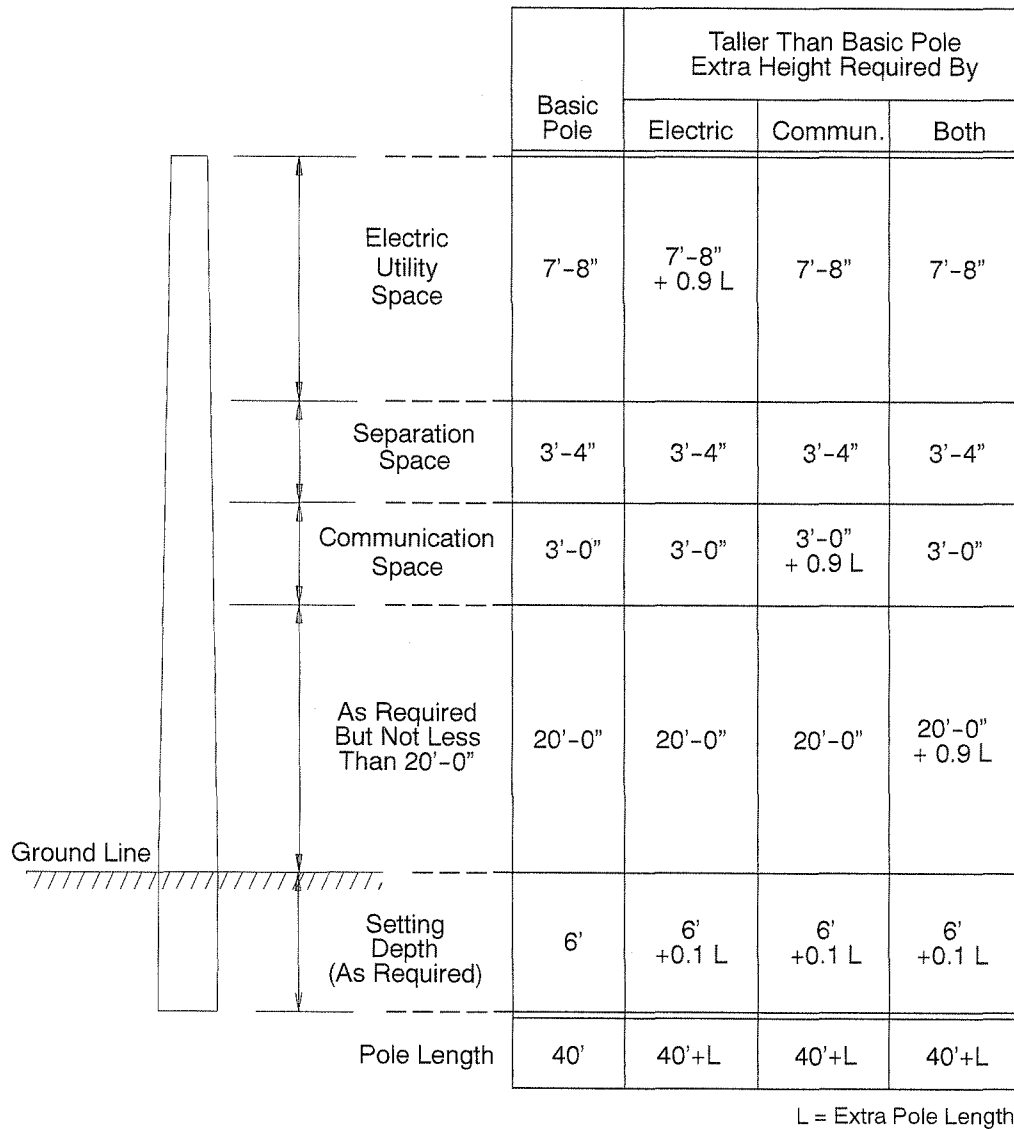

Figure 2 - Space Allocation on Poles Taller Than the 40-Foot Basic Pole

EU 101

4. 45-Foot Basic Pole

The allocation of space and the usual points of attachments for telephone, TV cable, and electric facilities depends on the length of the "basic pole". In many areas, the basic pole is 45 feet in length (about 38 1/2 feet above ground). Figure 3 shows the space allocations and the usual points of attachment for a 45-foot joint use pole.

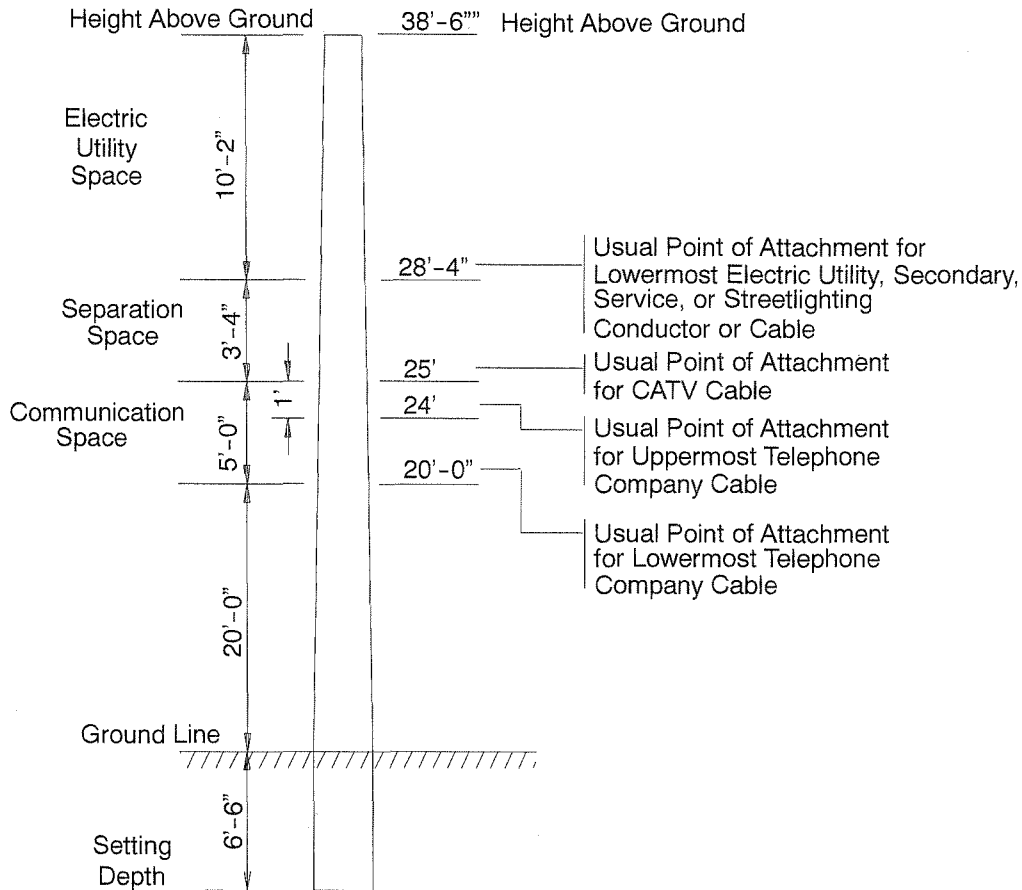

Figure 3 - Space Allocation on the 45-Foot Basic Joint Use Pole

5. Poles Taller Than the 45-Foot basic Pole

The company requiring extra pole height pays the extra cost and gets to use the extra height, less the 10% used by the deeper pole hole.

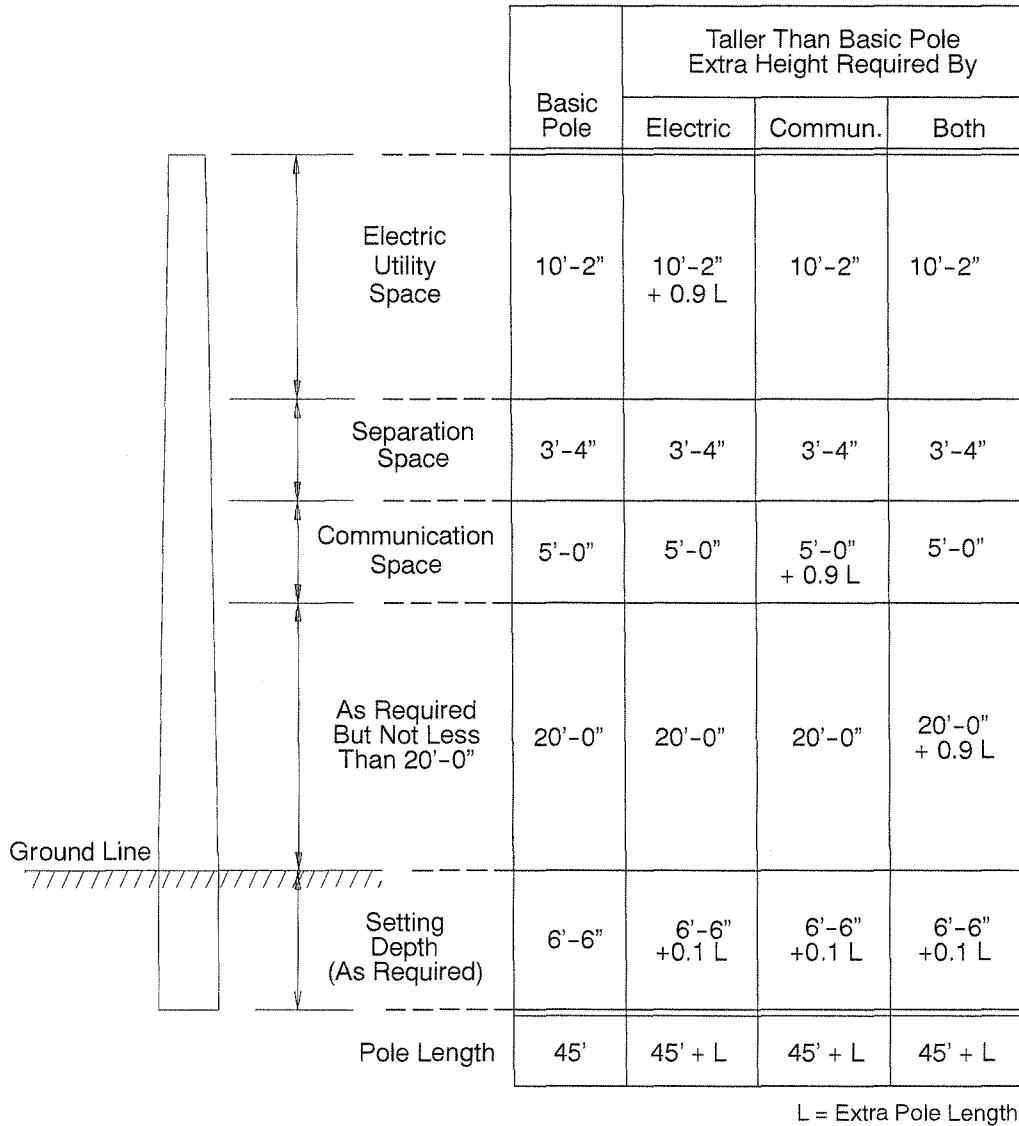

Figure 4 - Space Allocation on Poles Taller Than the 45-Foot Basic Pole

<p>Distribution Construction Standard © 2010 by PacifiCorp. All rights reserved.</p>	<p>Joint Use Pole Space Allocation</p>	<p>A MIDAMERICAN ENERGY HOLDINGS COMPANY</p>	<p>1 Oct 10</p>
<p>Engineer (D. Asgharian): <i>DDA</i> Standards Manager (G. Lyons): <i>GS</i></p>		<p>EU 101 Page 7 of 6</p>	

Joint Use—Climbing Space Through Communication Circuits

A. Scope

This standard provides information defining the climbing space requirements for joint use poles through the communication circuit level. Included are communication cables, service drops and vertical runs attached to the pole.

B. General

The climbing space as defined is intended to provide adequate clearances on the pole for safe ascent and descent by line personnel. The climbing space must extend 40 inches above and below the referenced communication—circuit or 48” above and below in California (see Figure 1). If the climbing space is rotated around the pole for continued climbing, the climbing spaces in different quadrants of the pole must overlap.

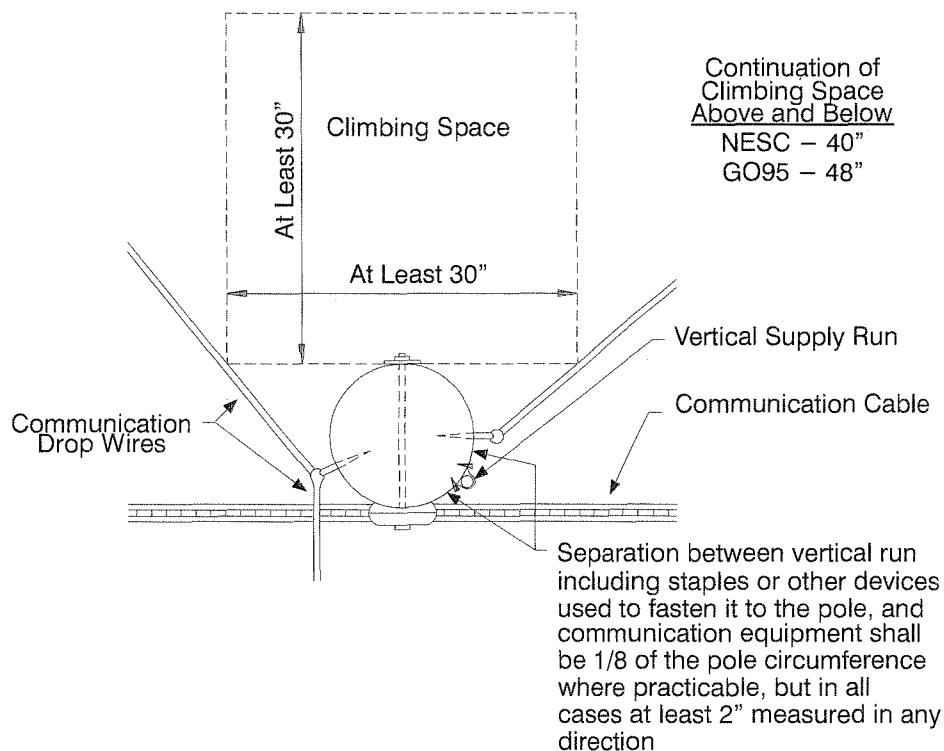

Figure 1 – Climbing Space

**Distribution
Construction Standard**

Engineer (N. J. Johnson):
Distribution Engr. (D. Norman):
Standards Services (D. Grimhall):

**Joint Use
Climbing Space Through
Communication Circuits**

PACIFICORP
PACIFIC POWER UTAH POWER

31 May 93

EU 211
Page 1 of 1

Joint Use—Clearances, Communication to Supply Circuits

A. Scope

This standard provides information regarding vertical clearances between PacifiCorp supply circuits and joint use facilities. Included are communication circuits, neutral supports and secondary supply supports.

B. General

The vertical clearances between company supply circuits and other utility attachments are specified in this standard.

1. Vertical Spacing - Crossarms

The vertical spacing requirements between company supply circuits and communication circuits varies depending upon the voltage level and NESC and/or state (California and Washington) jurisdiction (see Figure 1 and Table 1 for clearances.).

2. Vertical Spacing - Attachments to Pole

The vertical spacing requirements between company supply circuits attached to the pole and communication circuits depends upon the supply voltage level, effectively grounded cables and NESC and/or state (California and Washington) jurisdiction (see Figure 2 and Table 2 for clearances).

3. Open Wire Communications Circuits

It is not intended that there be any new joint use poles with open wire communications circuits. Clearance to these circuits is shown because some of this type of construction still exists.

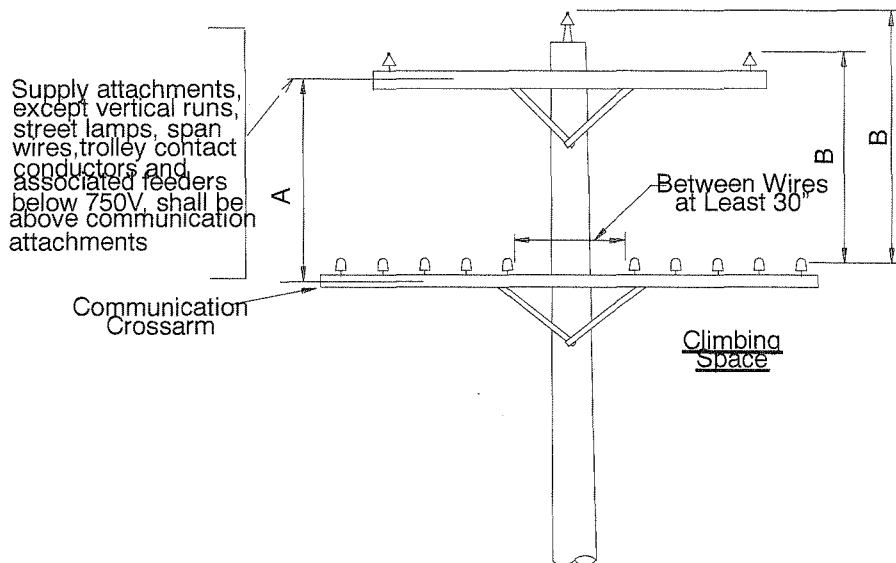

Figure 1 - Vertical Spacing of Crossarms and Circuits, Communication & Supply

EU 221

Table 1 - Vertical Clearance Between Supply and Communication Facilities

Voltage of Supply Circuit	Min. X-arm Spacing (In.) (Dimension A)	Min. Conductor Spacing (In.) (Dimension B)
NESC [1]		
0-8700	48	40
8700-50000	72	60
Washington [2]		
0-7500	48	40
Over 7500	84	84
California [2]		
0-7500	48	48
7500-75000	72	72

- [1] Voltage is to ground if an effectively grounded circuit, otherwise voltage is highest voltage between any two conductors.
- [2] Voltage is highest voltage between any two conductors.

California G. O. 95 exceptions, Dim. A
 Rule 92.1B
 0-750V supply on racks—A = 72"
 Supply cables—A = 48"

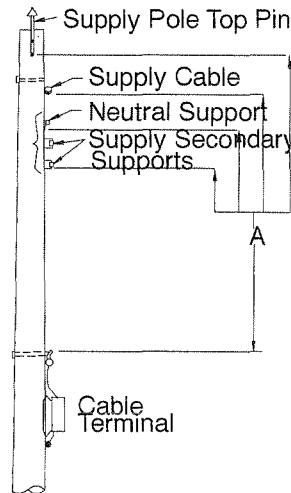

Figure 2 - Vertical Clearances Between Conductors and Noncurrent Carrying Metal Parts of Communication Equipment and Supply Circuits

Table 2 - Vertical Clearances Between Conductors and Noncurrent Carrying Metal Parts of Communication Equipment and Supply Circuits

Dim.	Washington		NESC		California	
	Voltage of Supply [2] Circuit Concerned	Min. Clearance Inches	Voltage of Supply [1] Circuit Concerned	Min. Clearance Inches	Voltage of Supply [2] Circuit Concerned	Min. Clearance Inches
A	0- 7500	40	0-8700	40	0-7500	48
	Over 7500	84	Over 8700	60	7500-75000	72



- ① Voltage is to ground if an effectively grounded circuit, otherwise same as ②.
- ② Voltage is highest voltage between any two conductors.

4. Horizontal Spacing

The preferred method of attaching communications cables to poles is to utilize one side of the pole with 12" minimum vertical separation between cables. This allows climbing on the other side of the pole. However, in certain circumstances, PacifiCorp will allow installation of communications cables on both sides of a pole, as long as there is a minimum of 30" horizontal separation between wires for climbing. This separation can be obtained by using fiberglass arms, strong enough to handle physical loads upon them and long enough to provide the needed 30" separation at the point of attachment to the pole (see Figure 1 and Figure 3).

(If Figure 1 is the attachment method being used, 30" horizontal measurements are required between cables. This measurement applies to any cables attached to the crossarm, but must also take into consideration any cable attached directly to the pole.)

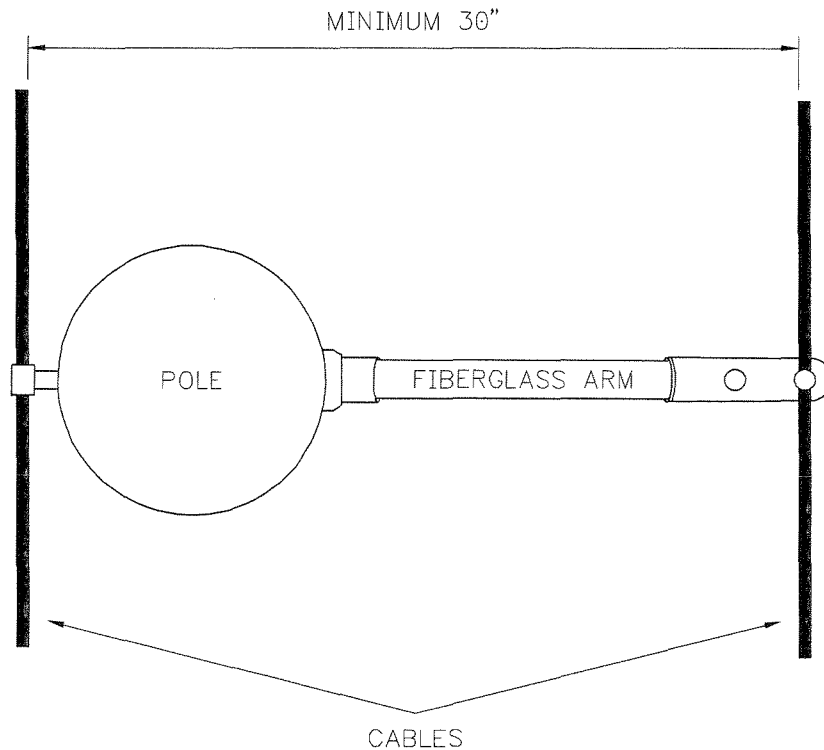

Figure 3 - Horizontal Spacing Using Fiberglass Arm

Distribution Construction Standard

© 2007 by PacifiCorp. All rights reserved.

Engineer (D. Asgharian): *DDA*
 Standards Manager (G. Lyons): *GL*

Joint Use—Clearances, Communication to Supply Circuits



8 Nov 07

EU 221
 Page 3 of 4

This page is left blank intentionally.



**Joint Use—Clearances,
Communication to
Supply Circuits**

**Distribution
Construction Standard**

© 2007 by PacifiCorp. All rights reserved.

Engineer (D. Asgharian): *DDA*
Standards Manager (G. Lyons): *GL*

Joint Use—Clearances Communication Above Ground Roadway or Water

A. Scope

This standard provides information regarding the minimum clearance required between joint use facilities attached to PacifiCorp structures and ground, roadways, and waterways.

B. General

The vertical clearances of all facilities attached to PacifiCorp structures must meet or exceed the minimum requirements of the National Electrical Safety Code (ANSI C2, current edition), GO95 and GO128 in the state of California, and any applicable state or local codes and the requirements of the PacifiCorp construction standards. These requirements shall apply to communication circuits, fiber optic lines, cable television circuits, messenger wires, guy wires and any other foreign owned facilities attached to PacifiCorp equipment.

In the event that the owner of a foreign facility is not a public utility company, then the attached facility must also comply with the provisions of the National Electrical Code (NEC, Part 70).

C. Application

1. Clearances shall be maintained at maximum loading conditions as defined by NESC rule 202 (in California use GO95 rule 07).
 2. PacifiCorp clearance requirements are found in section DC of the Distribution Construction Standards. PacifiCorp ground clearance requirements are found in section DC 111.
- In the event of conflicting requirements, the requirement which provides more clearance shall apply.

D. Special Requirements by State

1. California

The NESC is not applicable in California. The greater requirement of California GO95, or PacifiCorp clearances found in section DC shall apply.

Utah

For state and federal highways, the following requirements are to be followed:

- a) At intersections, minimum clearances are the applicable NESC clearance plus 10 feet.
- b) At other points adjacent to or crossing a state highway, minimum clearances are NESC clearances plus 8 feet.
- c) Crossing any public roadway, the minimum ground clearance is 18 feet.

Washington

Along or crossing a state or federal highway, 20 feet of ground clearance is required.

Distribution Construction Standard

© 1998 by PacifiCorp. All rights reserved.

Engineer (S. Waddoups): 

Stds Team Leader (D. Jones): 

Joint Use—Clearances Communication Above Ground Roadway or Water



20 Oct 98

EU 001
Page 1 of 2

EU 001

This page is left blank intentionally.



EU 001
Page 2 of 2

2 Oct 98

**Joint Use—Clearances
Communication Above
Ground Load and/or
Water**

**Distribution
Construction Standard**

© 1998 by PacifiCorp. All rights reserved.

Engineer (S. Waddoups):

Stds Team Leader (D. Jones):

Joint Use—Clearances Equipment to Risers

A. Scope

This standard provides information regarding the location of risers and vertical runs on joint use poles. Included are company owned supply risers, communication risers and ground conductors.

B. General

Risers and vertical runs on joint use poles shall be located on poles so as to minimize congestion, provide adequate climbing space and meet clearance requirements. Whenever practicable, risers and vertical runs shall be located on the away from traffic side of the pole. If supply and communication risers are required on the same pole, they should be installed in the same quadrant away from the climbing space. For typical arrangement of joint risers, see Figure 1. For preferred arrangements of risers and vertical runs on joint poles, see Figure 2. Supply cable risers shall be installed in approved protective conduit (see standard GC 051). Supply cable carried vertically through communication attachments and supply circuits shall be attached to the pole so as to meet or exceed minimum NESC clearance requirements in all areas and also meet or exceed the requirements of General Order 95 in California (see Figure 3).

**Distribution
Construction Standard**

Engineer (D. D. Shortt):
Stds Team Leader (D. Jones):

**Joint Use
Clearances
Communication
Equipment to Risers**

 **PACIFICORP**
PACIFIC POWER UTAH POWER

19 Nov 97

EU 001
Page 1 of 1

EU 001

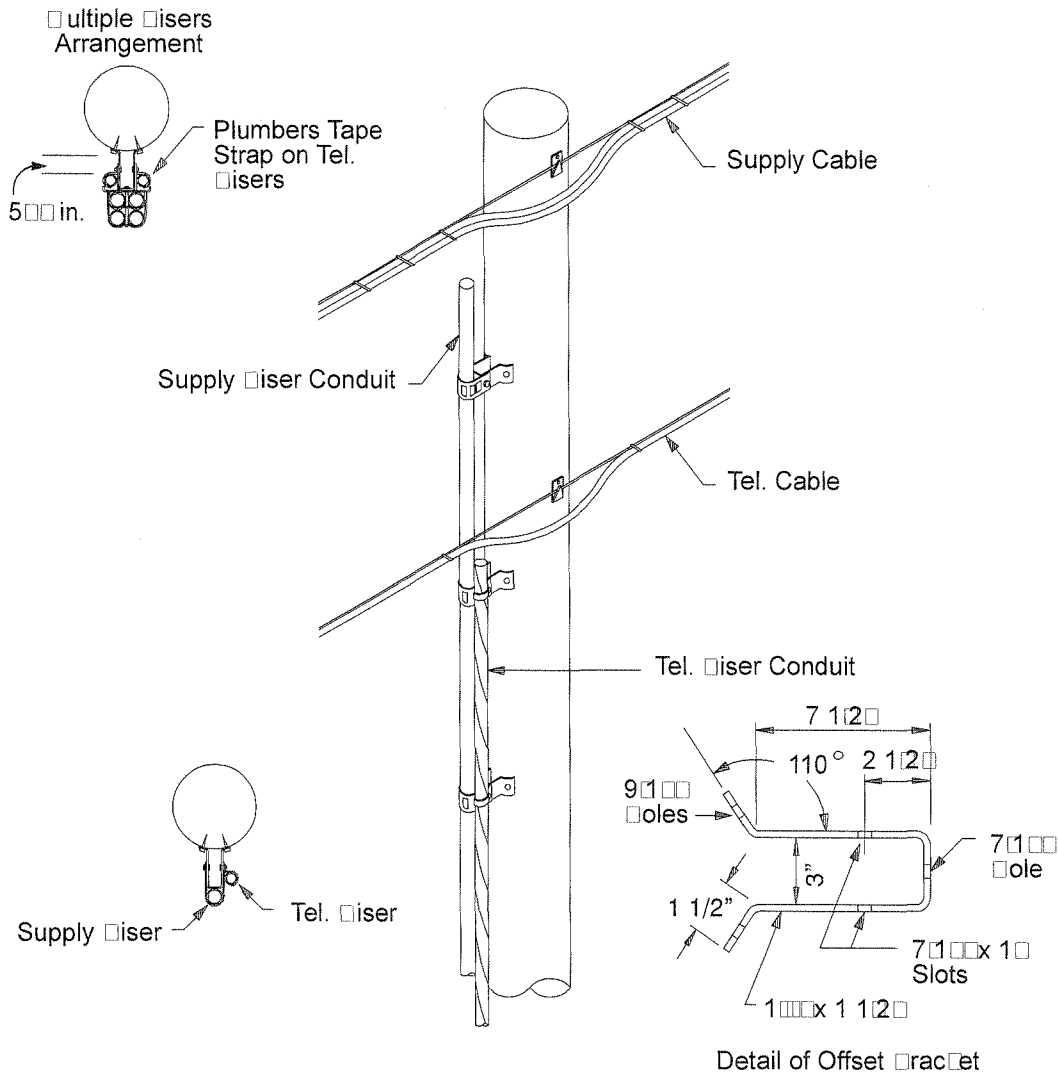

Figure 1 – Typical Arrangement of Supply and Communications Risers

REFERENCES

1. Arrangement for joint use of offset bracket for support of one supply riser and one communications riser. The actual offset bracket may be another approved style. Two or more supply riser conduits will always be on offset brackets, in which case the communications riser or risers shall also be on the brackets.
 2. All supply riser conduits shall be supported by offset brackets. Multiple risers, supply or communication or both shall be combined on a riser offset bracket. If a supply riser is installed on an offset bracket, the communication riser shall also be on the offset bracket.
- Spacing between brackets shall not exceed 10 feet and provide as much clearance as possible between pole and conduit surfaces but not less than 5 inches.

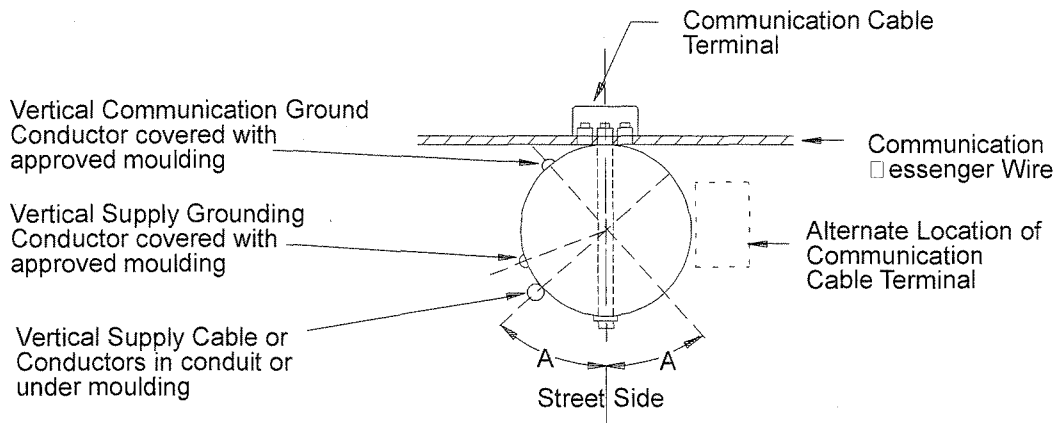

Figure 2 – Preferred Locations for Risers, etc. on Joint Use Poles

REQUIREMENTS

1. Whenever practicable, angle A should be approximately 15 degrees. The risers and vertical runs shall be located on the low side of rated and other non-vertical poles.
2. All supply riser conduits shall be supported by offset brackets. Multiple risers, supply or communication or both shall be combined on a riser offset bracket. If a supply riser is installed on an offset bracket, the communication riser shall also be on the offset bracket.
 - Spacing between brackets shall not exceed 10 feet and provide as much clearance as possible between pole and conduit surfaces but not less than 5 inches.
 - The clearance between supply hardware and communications hardware shall be as much as practicable but in no case less than 2 inches in any direction, except if all the following applies:
 - a) The systems and applicable codes involved would permit grounding of the hardware.
 - b) The hardware involved in the reduced clearance is effectively grounded at the location.
 - c) The hardware involved is mechanically and electrically securely bonded.

Applicable in California also if riser covering is of rigid PVC meeting requirements of G.O. 95.

<p align="center">Distribution Construction Standard</p>	<p align="center">Joint Use Clearances Communication Equipment to Risers</p>	<p align="center">PACIFICORP PACIFIC POWER UTAH POWER</p>
<p>Engineer (D. J. Shortt): Stds Team Leader (D. Jones):</p>		<p>19 Nov 97</p>

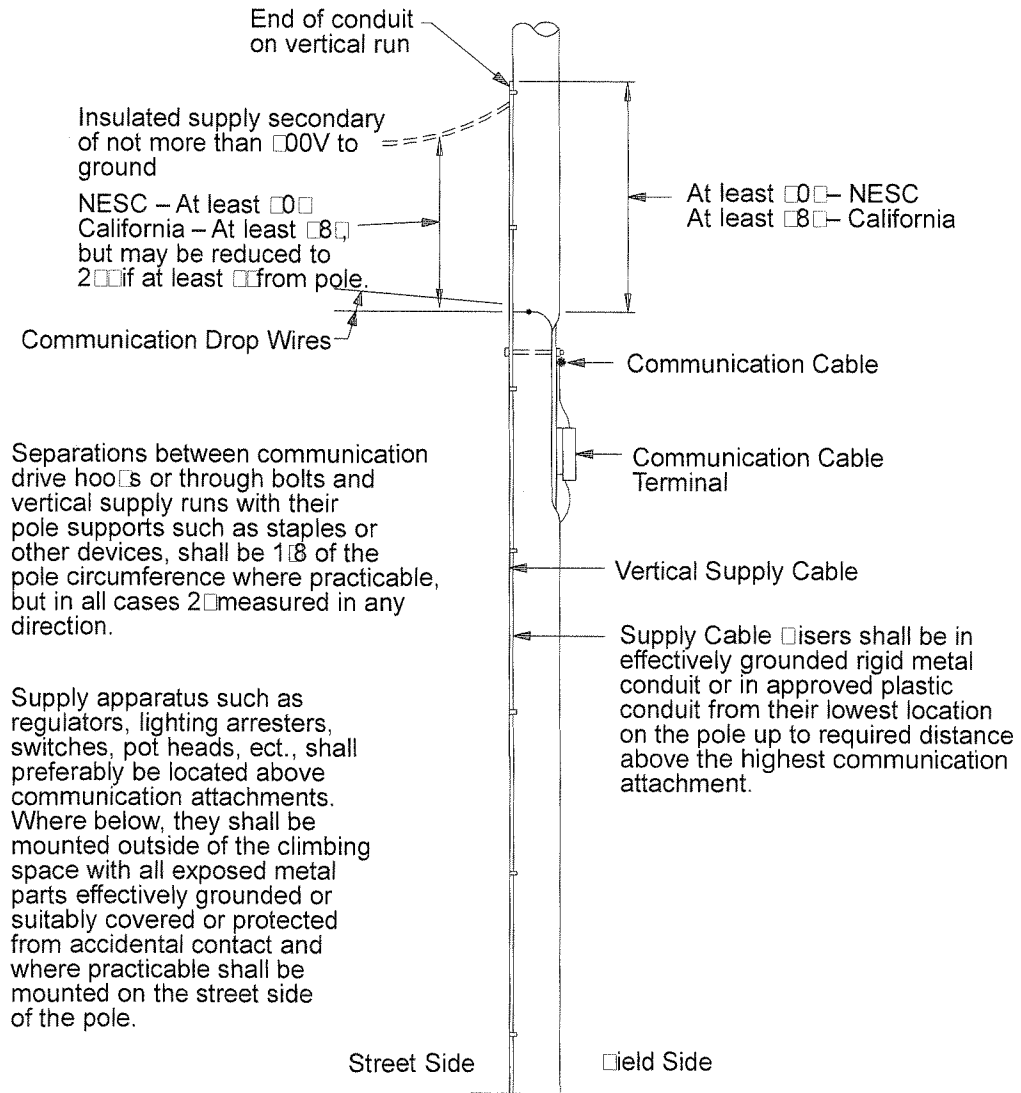

Figure 1 - Supply Riser on Joint Use Pole

Joint Use—Clearances Communication Equipment to Transformers

A. Scope

This standard provides information regarding clearances between communication cables and supply transformers attached to joint use poles.

B. General

Clearance requirements between communication cables and supply transformers vary according to geographic location and supply system voltage. For typical joint pole arrangement with supply transformer, see Figure 1. NESC and WAC (Washington) supply transformer clearances are identical (see Table 1). In California, G.O. 95 requirements exceed NESC clearances (see Table 1).

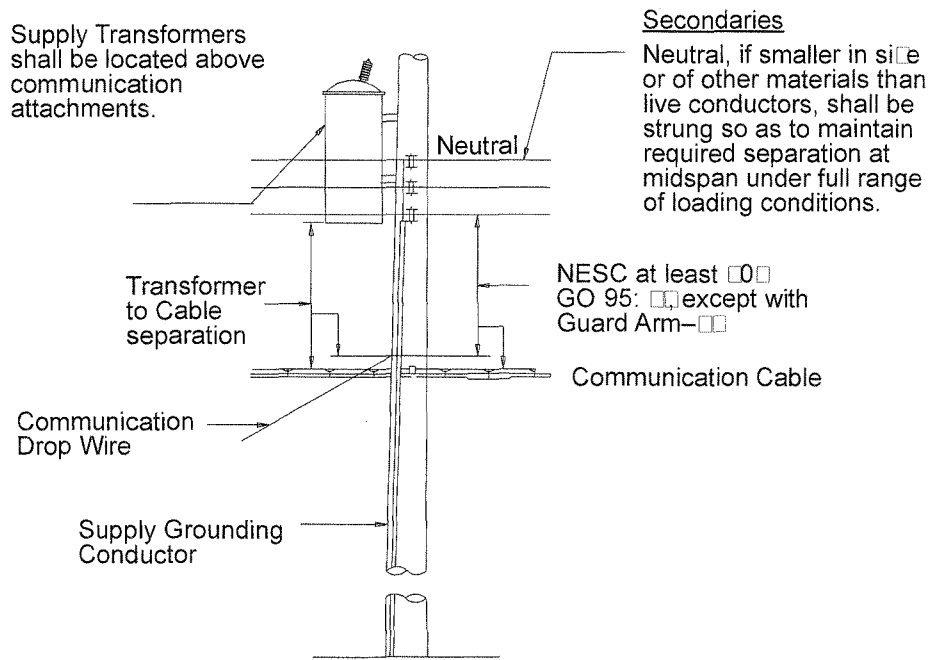

Figure 1 – Clearances Between Transformers and Communications Cables

Table 1 – Clearance from Transformers for Communication Cables

Transformer Primary Voltage	Minimum Clearance In Inches
NESC Washington	
0-8700	60 ①
8700-50000	60 ①
California	
0-750	72 ②
750-22500	72 ②

000ES

- ① If transformer cases are effectively grounded, these clearances may be reduced to 60 inches.
- ② With guard arm above communication cable, may be reduced to not less than 68 inches.

Joint Use—Clearances Communication Equipment to Street Lights

A. Scope

This standard provides information regarding vertical clearances between street lights and joint use facilities. Included are clearances from communication circuits and cable T.V. to street lights and street lighting supply drip loops (for California, see EU 271).

B. General

The vertical clearances between street lights, street lighting service drip loops, and communication facility attachments are specified in this standard.

1. Vertical Clearance—Communication Cable

The vertical clearances required between street lighting equipment and communication cables attached to the pole are defined on pages 2 and 3 of this standard. Street lighting may be installed above or below the communication level, provided that required clearances shown on pages 2 through 5 are met.

2. Vertical Clearance—Open Wire Telephone on Crossarm

The vertical and horizontal clearances required between street lighting equipment and open wire communication circuits on wood crossarm are defined on pages 4 and 5 of this standard. Street lighting may be installed above or below open wire communication circuits provided that required clearances shown on pages 2 through 5 are met.

Applicable in All States Except California

<p>Distribution Construction Standard</p>	<p>Joint Use Clearances Communication Equipment to Street Lights</p>	 <p>PACIFICORP PACIFIC POWER UTAH POWER</p>
<p>Engineer (E. Van Bronckhorst): Stds Team Leader (D. Jones): Standards Services (C. Grimhall):</p>		<p>8 May 95</p> <p>EU 001 Page 1 of 1</p>

ALL STATES EXCEPT CALIFORNIA

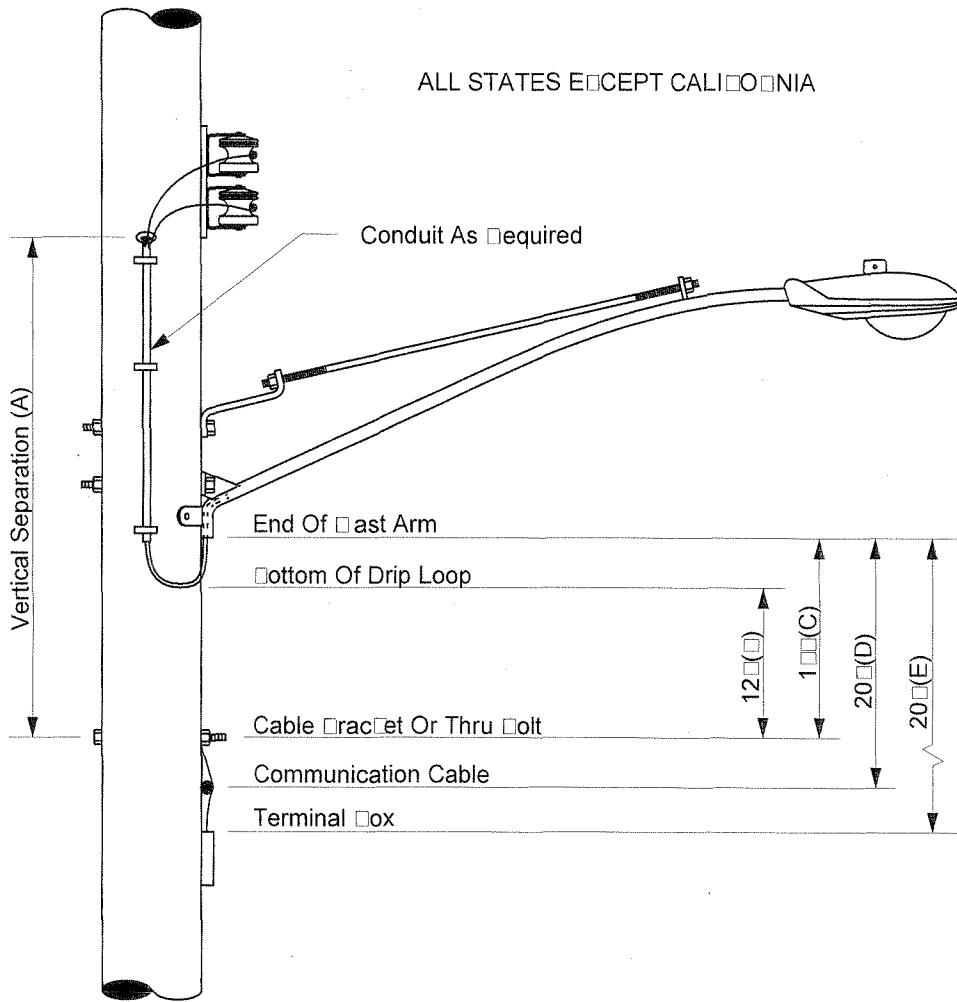

EXPLANATION

- A. Vertical Separation (NESC SEC. 2, 208-1)
 - If supply voltage is 0 – 8700 V
 - If supply voltage is over 8700 V
- B. Separation from Drip Loops of Street Light Brackets (NESC SEC. 2, 208.D)
- C. Separation from Communication Brackets (NESC SEC. 2, 208.2)
- D. Separation from Messengers Carried in Communication Cables (NESC SEC. 23, #238.2)
- E. Separation from Terminal Box of Communication Cable (NESC SEC. 23, #238.2)

EXCEPTIONS TO CLEARANCE REQUIREMENTS AND ADDITIONAL NOTES, SEE PAGE 6

Figure 1 – Street Lighting Facilities Above Communication

ALL STATES EXCEPT CALIFORNIA

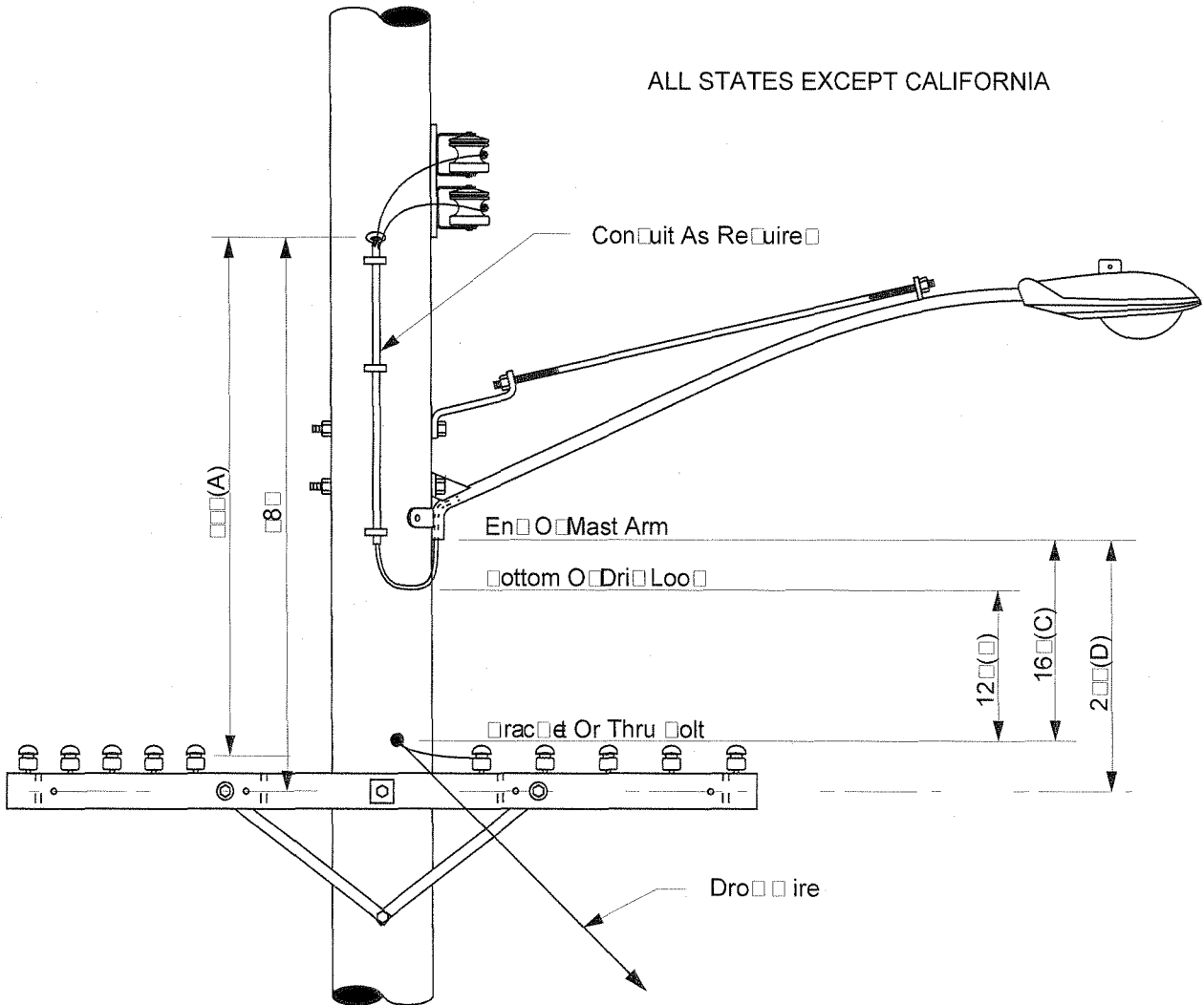

NOTES

- A. Vertical Separation (NESC SEC. 23, #238-1)
 - □ □ □ voltage is 0 - 8000
 - 6000 voltage is over 8000
- B. Separation from Trip Loop of Street Light Bracket (NESC SEC. 23, #238.D)
- C. Separation from Communication Bracket (NESC SEC. 23, #238.2)
 - . Separation above Communication Crossarm (NESC SEC. 23, #238.2)

EXCEPTIONS TO CLEARANCE REQUIREMENTS AND ADDITIONAL NOTES, SEE PAGE 6

Figure 2 - Street Lighting Above Communication Open Wire Crossarm

<p>Distribution Construction Standard</p> <p>Engineer (E. Dan Cronquist) Staff Team Leader (D. Jones) Standards Services (M. Grimhall)</p>	<p>Point to Point Clearance Communication Equipment to Street</p>	<p>PACIFICORP PACIFIC POWER UTAH POWER</p> <p>8 March</p> <p>E □ □ □ □ Page 3 of 6</p>
---	--	---

E □ □ □ □

ALL STATES EXCEPT CALIFORNIA

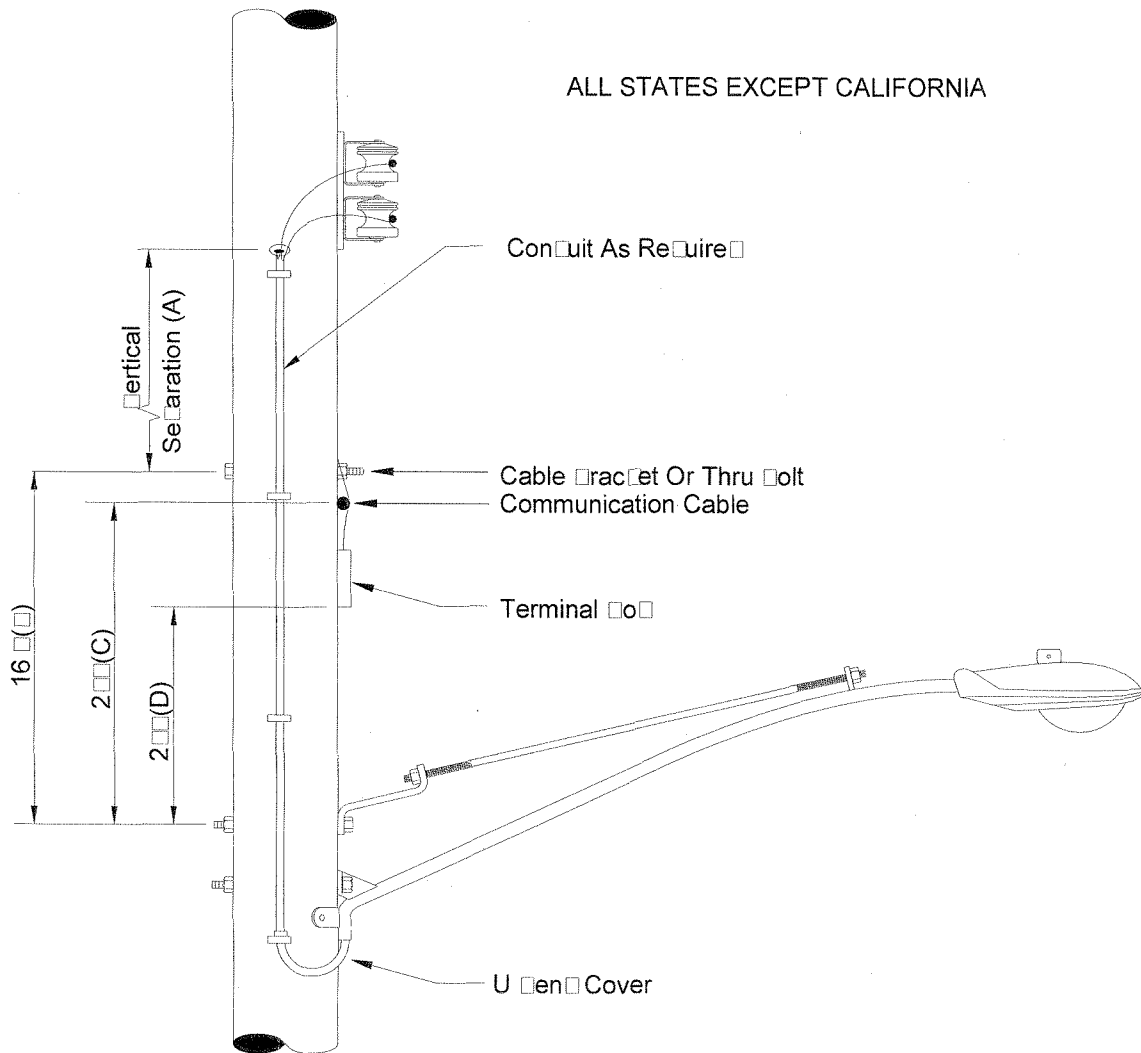

NOTES

- A. Vertical Separation (NESC SEC. 23, #238-1)
 - □ □ □ voltage is 0 - 8000 □
 - 6000 □ voltage is over 8000 □
- B. Separation from Communication Bracket (NESC SEC. 23, #238.2)
- C. Separation from Messenger Carried Communication Cable (NESC SEC. 23, #238.2)
- D. Separation from Terminal Box of Communication Cable (NESC SEC. 23, #238.2)

EXCEPTIONS TO CLEARANCE REQUIREMENTS AND ADDITIONAL NOTES, SEE PAGE 6

Figure 3 - Street Lighting Facilities Clear Communication

ALL STATES EXCEPT CALIFORNIA

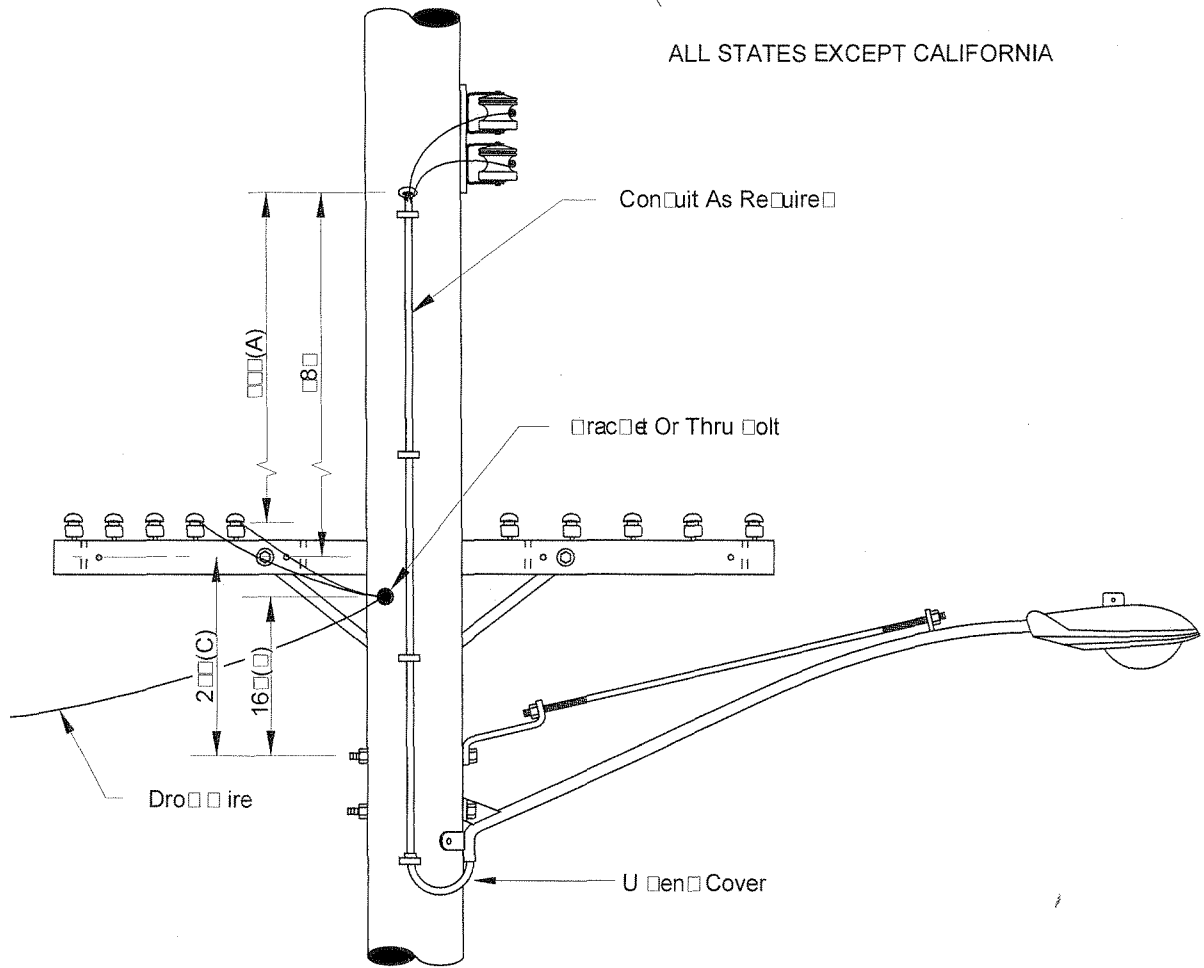

NOTE

- A. Vertical Separation (NESC SEC. 23, #238-1)
 - 600V or less voltage is 8 feet
 - Over 600V voltage is over 8 feet
- B. Separation from Communication Bracket (NESC SEC. 23, #238.2)
- C. Separation Below Communication crossarm (NESC SEC. 23, #238.2)

EXCEPTIONS TO CLEARANCE REQUIREMENTS
AND ADDITIONAL NOTES, SEE PAGE 6

Figure 1 - Street Lighting Below Communication Open Wire Crossarm

<p>Distribution Construction Standard</p> <p>Engineer (E. Dan Cronquist) Staff Team Leader (D. Jones) Standards Services (M. Grimhall)</p>	<p>Point to Clearance Communication Equipment to Street</p>	<p>PACIFICORP PACIFIC POWER UTAH POWER</p> <p>8 March</p> <p>E □ □ □ □ Page 6 of 6</p>
---	--	---

C. Exception to Clearance Requirement Section

Vertical Separation as Illustrated on Sheet 000000 and 00

Where noncurrent carrying parts of equipment and support cables are effectively grounded consistently throughout all line areas, and where communication is at lower levels, separations may be reduced to 30 inches.

Conditions for a Reduction in Required Separation

The following dimensions may be reduced in special cases:

- i) C, D, and E as illustrated on sheet 2
- ii) C, and D as illustrated on sheet 3
- iii) A, C, and D as illustrated on sheet 00
- iv) A, and C as illustrated on sheet 00

These special cases are as follows:

- a) The separation may be reduced to 12 inches for either span wires or metal parts of brackets at points 24 inches or more from the pole surface.
- b) The separation may be reduced to 12 inches if the noncurrent carrying metal parts of the street light assembly are effectively grounded.

Other Exception

For dimension A on sheets 2 and 3, the distance of 12 inches may be reduced to 3 inches if the loop is covered by a suitable nonmetallic covering which extends at least 2 inches beyond the loop.

Drill loop requirements do not have to be followed if the support run is in continuous conduit or covered by a U bend.

For California installations, see EU 201.

Applicable in All States Except California



**Point to Point
Clearance
Communication
Equipment to Street Light**

**Contribution
Construction Standard**

Engineer (E. Dan Bronckhorst)
Staff Team Leader (D. Jones)
Standards Services (M. Grimhall)

Joint Use Clearance Communication Equipment to Street in California

A. Scope

This standard provides information regarding clearances between streetlights and communication attachments on joint use poles in the State of California. Included are open wire communication circuits on crossarms, cable attached directly to the pole and secondary support circuits.

B. General

Joint use clearances for streetlights installed in California are under the jurisdiction of GO which equals or exceeds NESC requirements. Streetlights may be installed above or below communication circuits provided that required clearances are met (see Figure 1 below for clearances).

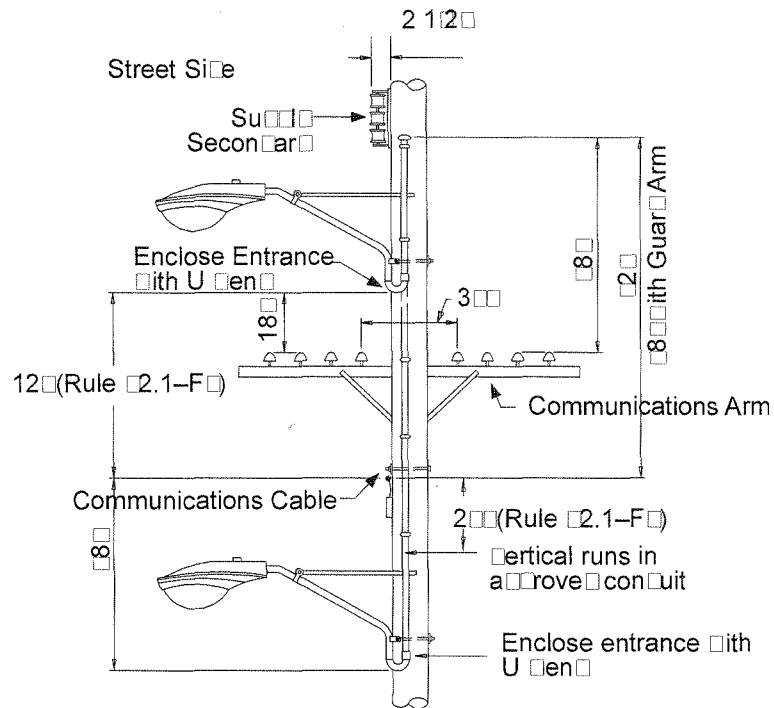

Figure 1 – Clearances between Street Lights and Communication Attachments

NOTE

- Clearances are 2 Inches

**Distribution
Construction Standard**

Engineer (D. M. Shortt) *DS*
 Staff Team Leader (D. Jones) *RT*
 Standards Services (M. Grimhall) *MG*

**Joint Use
Clearance Communication
Equipment to Street in
California**

PACIFICORP
 PACIFIC POWER UTAH POWER

2 Series

E 0000
 Page 1 of 2

E 0 000

This page is left blank intentionally



PACIFICORP



PACIFIC POWER UTAH POWER

E 0 000
Page 2 of 2

2 Se 000

Joint 000
Clearance 00 Communication
Equipment to Street 0000
California

Contribution
Construction Standard

Engineer (D. M. Shortt) 
Staff Team Leader (D. Jones) 
Stanards Services (M. Grimhall) 

Joint Use—Clearances, Low Voltage Service Drops

A. Scope

This standard provides information regarding clearances between company owned supply service drops and communication attachments on joint use poles in California, Washington, and all other service areas.

B. General

This standard includes clearances between supply service drops from 0–750V and open wire communication circuits on crossarms (see Figure 1 below for clearances).

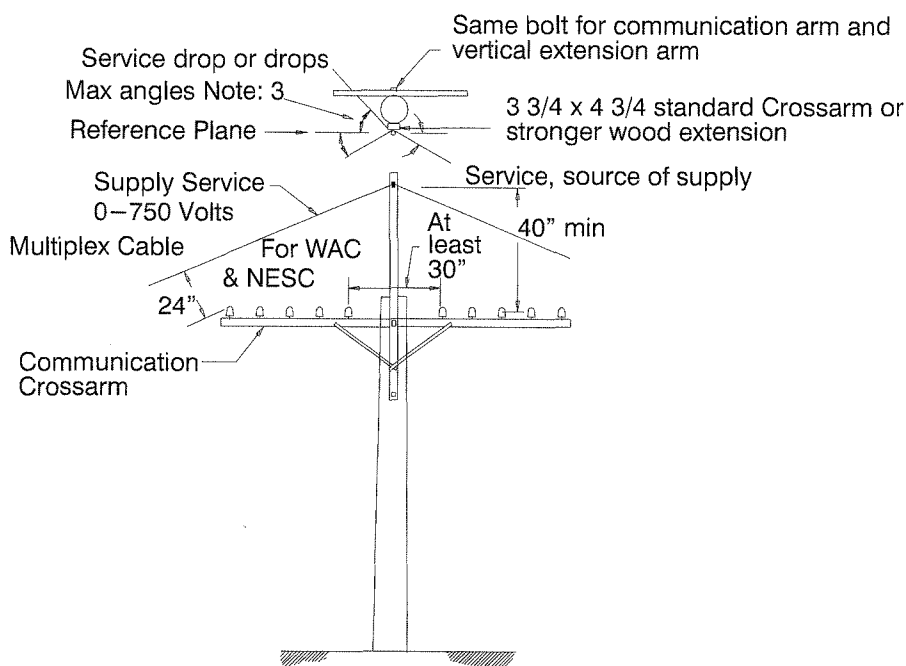

Figure 1 – Service Drop Contacts on Communications Poles

Notes:

1. Use pole top fixture when following conditions exist:
 - a. Not more than 2 branches to service
 - b. Span from supply pole to communication pole not over 100 Ft. and span from communication pole to house not over 100 ft.

**Distribution
Construction Standard**

Engineer (N. Johnson)
Distribution Engrg. (D. Norman)
Standards Services (M. Grimhall)

**Joint Use
Clearances, Low
Voltage Service Drops**

PACIFICORP
PACIFIC POWER UTAH POWER

31 May 93

EU 281
Page 1 of 2

EU 281

- c. Maximum size of service wire from communication pole to house is # 2 triplex.
2. Where conditions are more severe than shown by drawing or as limited by note 1, then each such case must be individually planned.
3. Angle of service crossing and service drop or drops to a plane normal to the alignment of the pole line shall not exceed 45 degrees.



EU 281
Page 2 of 2

31 May 93

**Joint Use
Clearances, Low
Voltage Service Drops**

**Distribution
Construction Standard**

Engineer (N. Johnson)
Distribution Engrg. (D. Norman)
Standards Services (M. Grimhall)

Joint Use—CATV on Poles

A. Scope

This specification details the clearances, locations and equipment involved in the installation of Community Antenna Television (CATV) auxiliary equipment on PacifiCorp poles.

B. General

1. CATV auxiliary equipment consists mainly of power supplies and separate service protection disconnects. An installation usually consists of a 120V service in conduit to a service disconnect, a metal cabinet with a 120V AC to 60V AC or DC power supply (batteries optional), and a return supply line (usually 1/2-inch coax) to the main CATV cable. An amplifier is usually supported on the CATV cable messenger at least 18 inches away from the pole. The return supply line terminates at the amplifier or other termination device suspended by the CATV messenger.
2. *CATV companies are Licensees and prior to installation, must make special written application to PacifiCorp to use space outside the normal communications space on PacifiCorp poles, as well as application to receive electrical service. PacifiCorp is concerned that additional equipment fastened to the pole not impair PacifiCorp's use of facilities nor lessen the margin of safety for our crews. In order that these conditions may be met, future installations must meet the requirements in Section C. PacifiCorp will reserve the right to decline electrical service until all requirements of this specification are met.*
3. Vertical pole space allocations for joint use distribution poles are given in PacifiCorp Standard EU 101.

C. Installation Requirements

1. All CATV equipment installations on company owned poles shall meet the requirements of the latest edition of the National Electrical Safety Code (NESC) applicable in Oregon, Idaho, Montana, Utah, and Wyoming; GO-95 in California; or the latest edition of the NESC applicable in Washington, except as superseded by the Washington Administrative Code (WAC).
2. CATV auxiliary equipment shall not be installed on poles having conduit risers or poles having gang-operated switches, capacitors, reclosers, or regulators. Any rearrangement of facilities required for auxiliary CATV equipment located outside the normal communication space allocation will be made at PacifiCorp's option and at the Licensee's expense.
3. The maximum size auxiliary equipment cabinet which may be installed on the pole, is limited to 26 inches wide by 26 inches high by 20 inches deep, exclusive of mounting bracket(s). The service disconnect, when attached to one end of the cabinet, is also excluded from these dimensions. No more than one such cabinet may be attached to a pole. A service disconnect may be installed separately above the cabinet, and if so installed, shall be on the same side of the pole. The service disconnect may be attached directly to the pole providing the dimensions of the service disconnect are no greater than 6 inches wide by 12 inches high by 6 inches deep.

<p>Distribution Construction Standard © 2010 by PacifiCorp. All rights reserved.</p>	<p>Joint Use—CATV on Poles</p>	 <p>A MIDAMERICAN ENERGY HOLDINGS COMPANY</p>
<p>Engineer (D. Asgharian): <i>DDA</i> Standards Manager (G. Lyons): <i>GL</i></p>		<p>1 Oct 10</p>

EU 401

If the auxiliary equipment is to be supplied by a portable generator during outage conditions, the service disconnect shall have a visible-break, double pole, double-throw switch to avoid back-feeding the utility service.

- Equipment mounted on a pole must not restrict the ability of an electric worker to climb past it. If the equipment cabinet is more than 12 inches in height, as shown in Figure 1, it must be mounted on offset brackets that provide a space for the electric worker to use a belt. This space must be at least 4 1/2 inches wide by 6 inches high, as shown in Figure 2. These brackets shall be installed with through bolts. The through bolt ends shall not protrude more than 1 inch beyond the nut on other side of the pole. Use of wood crossarms or plastic mounting brackets is not acceptable. All holes bored in PacifiCorp's poles shall be flooded with a 2 percent solution of copper naphthenate before bolt insertion. Any unused pole holes due to misdrilling or equipment removal shall be flooded and plugged with treated dowels.

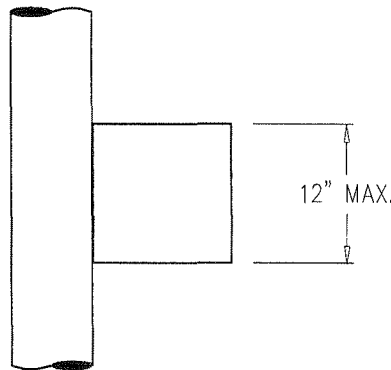

Figure 1 - Maximum Height of Directly Mounted Equipment Cabinet

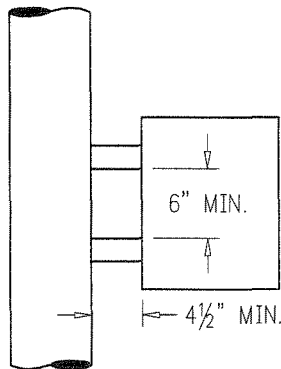

Figure 2 - Equipment Cabinet with Mounting Brackets

- The auxiliary cabinet and associated service equipment shall be installed in an orientation on the pole that allows a 30-inch-square minimum climbing space as shown in Figure 3. This climbing space shall extend vertically 48 inches above the uppermost portion and below the lowest portion of any installed auxiliary equipment.
- If the climbing space is rotated around the pole for continued climbing, the climbing spaces in different quadrants of the pole must overlap. The lowest point of any cabinet,



conduit, or cable shall be 12 feet above the ground. If any part of an enclosure overhangs a roadway shoulder, the minimum distance to the lowest portion shall be 15 feet. Enclosures overhanging roadways shall have at least a 16-foot clearance.

7. All work that is done above the joint use communications space shall be performed only by workers who are trained and qualified to work in the electric utility space, and have PacifiCorp authorization to perform the specific work. The electric service riser shall be provided and installed at the cost of the Licensee. The riser, as shown in Figure 4, shall be run in PVC Schedule 40, electrical grade conduit, attached to the pole at no greater than 30 inch intervals. A PVC service entrance fitting shall also be used. The return supply line from the cabinet to the main CATV cable position shall be covered with plastic or wooden molding, as appropriate, where the supply line is in contact with the pole (see Figure 3).

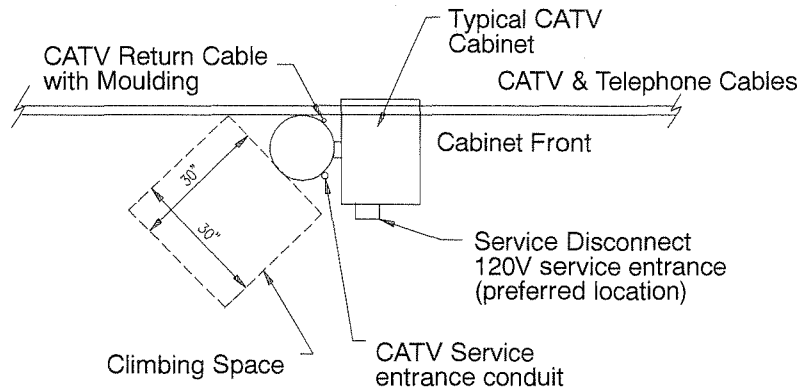

Figure 3 - Climbing Space

8. All metallic enclosures shall be effectively grounded. The minimum grounding conductor size shall be #6 AWG soft drawn copper. The enclosure grounding conductor shall be attached to the power system grounding conductor, if available, by means of a compression connector or other approved fitting. This connection shall be in the communications space only. If the pole ground is not available, the communication utility shall request the installation of a pole ground by PacifiCorp. The Licensee shall provide and install any or all of the above grounding material if it is not already existing at the pole (see Figure 4).
9. The communication utility shall not attach their guy wires to PacifiCorp's anchors I think unless explicit written permission is given for each specific location. Anchor rod auxiliary eyes are not permitted on PacifiCorp anchors. Additionally, all guy wires installed on PacifiCorp anchors to support communication utility's equipment or cable shall be insulated as defined by Rule 279A2a of the NESC, and in accordance with PacifiCorp standard practice. In addition to meeting code, this practice prevents galvanic corrosion of anchors. The insulator shall meet NESC flashover and strength requirements. If, by written permission, PacifiCorp allows the guy wire to be bonded at the pole, an insulator is still required that meets NESC strength requirements as stated in NESC Rules 279A3 and 279A1c.
10. Slack span installations and unguayed dead-end pole installations by communications licensee companies are not allowed on PacifiCorp-owned poles unless:

<p>Distribution Construction Standard © 2010 by PacifiCorp. All rights reserved.</p>	<p>Joint Use—CATV on Poles</p>	
<p>Engineer (D. Asgharian): <i>DDA</i> Standards Manager (G. Lyons): <i>GL</i></p>		

EU 401

- a) The communications company provides a complete engineering design and review, signed and stamped by a licensed Professional Engineer.
- b) The engineering review shall be included in the application, with all tensions, strengths, angles and calculations associated with the proposed slack span or unguyed deadend installation, and:
- c) Receipt of the Professional Engineer's design and review is acknowledged in writing by PacifiCorp.

All guy wires attached to the communication utility's own anchors shall meet NESC requirements.

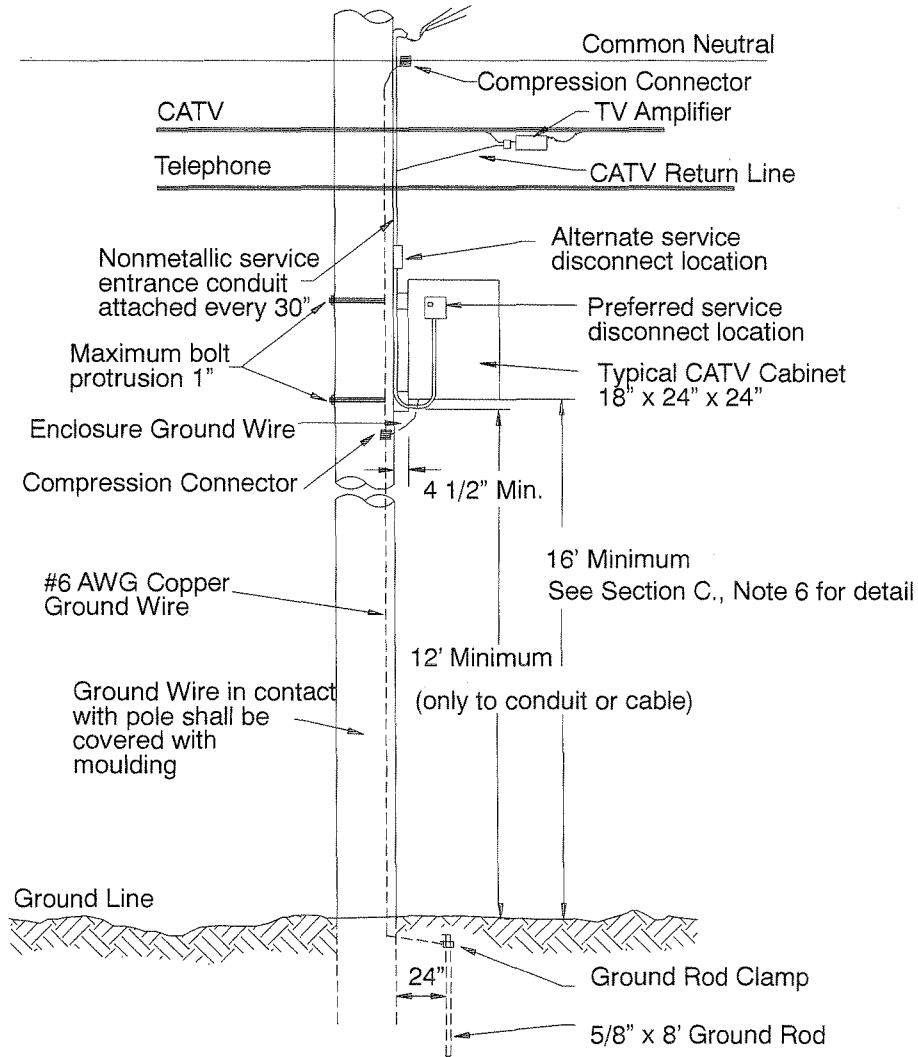

Figure 4 - Typical Installation of CATV Auxiliary Equipment with Grounding



Joint Use—CATV on Poles

Distribution Construction Standard

© 2010 by PacifiCorp. All rights reserved.

EU 401
Page 4 of 4

1 Oct 10

Engineer (D. Asgharian): *DDA*
Standards Manager (G. Lyons): *GL*

POLE ATTACHMENT AGREEMENT ROCKY MOUNTAIN POWER AND ZAYO GROUP

Exhibit D

Page 0 of 8

Rocky Mountain Power's Engineering Handbook

This Page left intentionally blank

2U.2—Wi-Fi Antenna Installation Guidelines

1 Scope

This document covers the installation of wi-fi type antennas on distribution and streetlight poles. The guidelines contained herein are intended to avoid operational problems and to ensure installations comply with existing laws and regulations. This guide is not considered to be all-inclusive. Depending on the local operating and weather conditions, deviations from this document may be required as determined by local operations staff.

2 Special Conditions

Any attachment to supply-line or fiber systems where a wireless terminal is attached in the supply space and a tail or lead traverses the distance from the supply space into the communication space of the attached structure is prohibited. If the wireless device must connect to supply-line or fiber systems in the communications space, it shall be installed on a separate structure unless the wireless device is also permitted in the communication space.

3 Coordination between PacifiCorp and the Attaching Entity

Close coordination with the attaching entity will be necessary to complete the installation. This guideline may be shared with the attaching entity prior to designing the installation so that they may be aware of PacifiCorp's basic requirements. Following are detailed requirements for attachments to PacifiCorp poles. For a checklist of deliverables due to the PacifiCorp Joint Use department, see Section NO TAG.

3.1 Attachment agreement

Entities wishing to install any equipment on PacifiCorp's poles shall have a signed Attachment Agreement in effect prior to making application for attachment. If such an agreement is not currently executed, please contact PacifiCorp's Joint Use department to arrange one.

3.2 Making an Application

All requests from any attaching entity wishing to install a wi-fi antenna on any PacifiCorp facility shall be sent to the PacifiCorp Joint Use department in Portland, Oregon. Prior to installing any equipment on PacifiCorp's pole, the attaching entity shall make application and receive written approval from PacifiCorp to attach the antenna. PacifiCorp may accept a proposed location, require changes to allow the installation at the attaching entity's expense, or decline the proposed location.

No installation shall commence until written approval is given from PacifiCorp's Joint Use department. The request shall identify the applicant, the installation contractor, the

address of the pole, the facility point number (from the pole tag) if present, and a photograph of the upper portion of the pole or streetlight, including the surrounding wires and aerial space. In addition, the following information is required:

3.2.1 Wi-Fi Antenna Information

Requester shall provide PacifiCorp a copy of the wi-fi antenna's physical and electrical information. This document shall have information on radio frequency (RF) exposure from the wi-fi antenna. The antenna's RF shall be in accordance with the Federal Communications Commission (FCC) regulations regarding RF exposure from antennas to workers. Also, requester shall clearly and conspicuously post signs indicating:

- Safe working distance (approach distances) from the device; and
- Contact information for field workers, including information for temporary disabling of antenna at the site.

3.2.2 Electrical Load Information

Requester shall supply information for electrical connection, such as demand in kW, voltage required, and method of connection to source. PacifiCorp is not responsible for possible poor performance of the electrical supply due to incorrect information provided by the customer.

3.2.3 Physical Information for Devices

Requester shall provide physical dimensions for the device and antennae as well as weight information. A typical installation drawing or photo shall be submitted which demonstrates that the antenna is designed so as not to experience wind loading of more than four pounds per square foot based on 40 MPH wind.

3.3 Zoning and Permits

Requester is wholly responsible for obtaining all government-required permits and approvals. Furthermore, requester is responsible for removing the equipment if requested by the local authority.

3.4 Removal cost

The equipment owner shall incur all costs of removing the equipment from a pole in the event that the equipment is abandoned or no longer in service.

4 General Installation Requirements

This section identifies the basic requirements for a wi-fi antenna installation on a distribution or streetlight pole. For further detail on installation requirements, see the PacifiCorp Distribution Construction Standards, *EU—Joint Use*.

4.1 Installation on Streetlight-Only Poles

Antennas may be installed on streetlight-only poles without any utility primary wires or Joint Use attachments, provided the installation does not interfere with maintenance of the structure or streetlight.

All installations shall be made and maintained in compliance with the current National Electrical Safety Code (NESC), or if in California, General Order 95 (GO 95).

No additional devices are allowed on the pole without prior approval from the PacifiCorp Joint Use department.

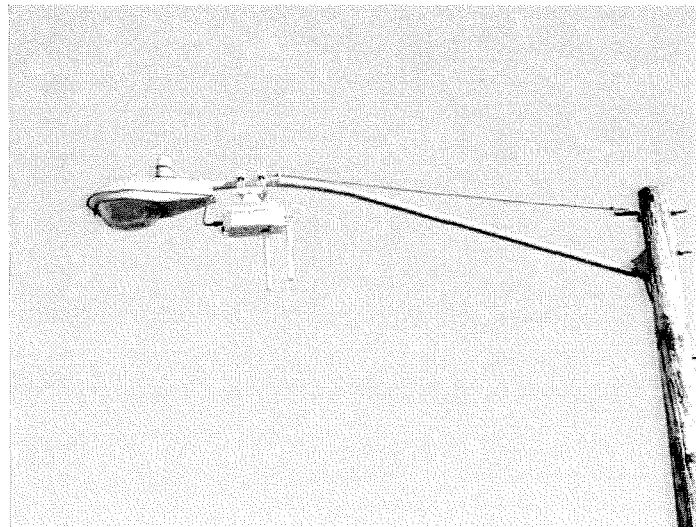

Figure 1—Typical Wi-Fi Antenna Installation on Streetlight Pole

4.2 Installation on Distribution Poles

Antennas may be installed on primary and/or secondary distribution poles, either: 1) on the streetlight mast, provided the streetlight is located in the power supply space, or 2) on the pole in the communication space, using extension arm or crossarm construction, provided material and strength specifications are suitable and approved for such installations.

All installations shall be made and maintained in compliance with the current NESC, or if in California, GO 95.

No additional devices are allowed on the pole without prior approval from the PacifiCorp Joint Use department

The following figures illustrate proper antenna installation on distribution poles.

Antenna shall be installed by qualified workers on streetlights located in the power supply space.

Clearance in any direction will be based on rule 235I, table 235-6, row 1b (3" to neutral, 3" to secondary, and 6" plus 0.4" per KV in excess of 8.7 KV line to line primary voltage).

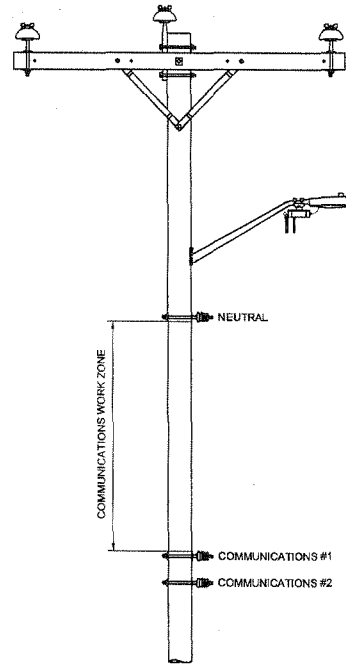

Figure 2—Antenna Installed in Power Supply Space

No antenna shall be attached to streetlights located in the communication worker safety zone, as described in rules 235C4 and 238E of NESC.

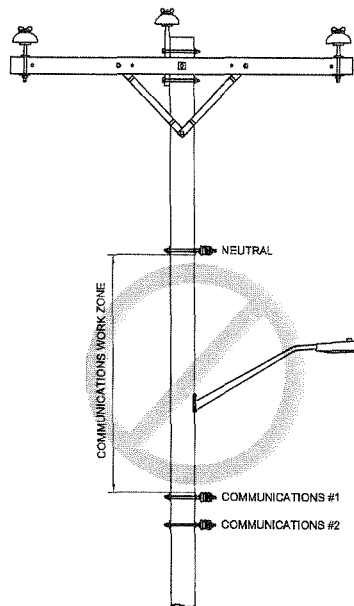

Figure 3—No Antennas on Streetlights in Communication Worker Safety Zone

Antenna may be installed in the communication space if attached to the pole. Antennas may not be installed on light fixtures located in the communication space

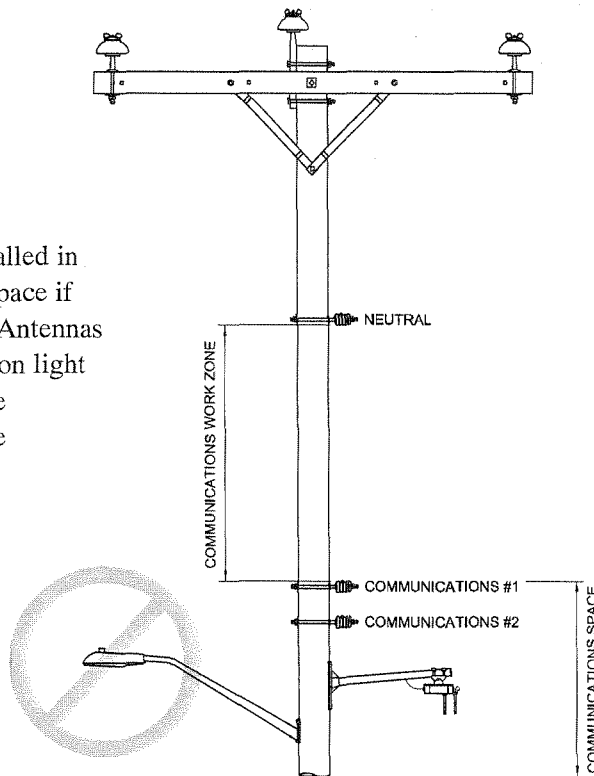

Figure 4—Antenna Installed on Pole in Communication Space

Installations shall not impede the climbing space on the pole. The climbing space is intended to provide adequate clearances on the pole for safe ascent and descent by the crew. The climbing space must extend 40" (48" in California) above and below the communication circuit.

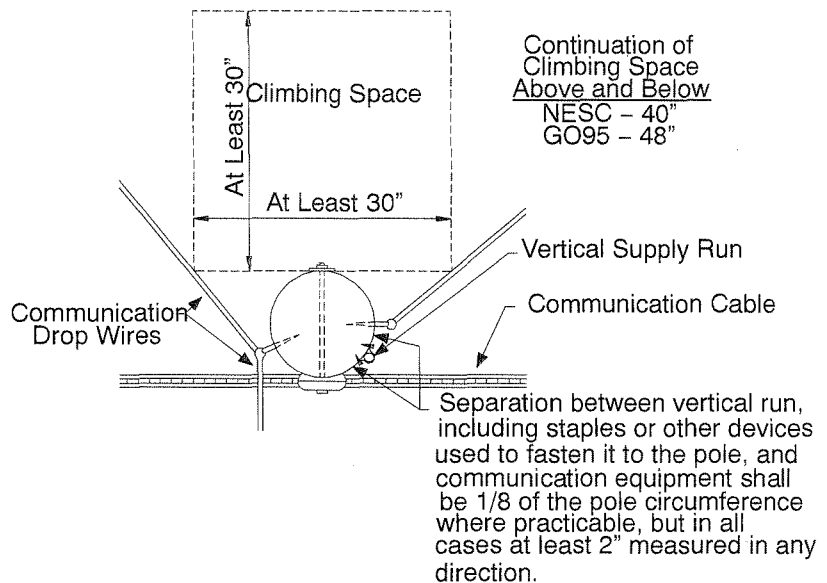

Figure 5—Climbing Space

5 Code requirements

5.1 Compliance with safety codes and rules

All attachments and work performed shall meet or exceed the requirements of the latest edition of the NESC (for example, rules 224A, 230C, 235C, 235I, 236, 238B, 238E, 239H, Section 42, Section 44 and 420Q); the Occupational Safety and Health Administration (rules 1910.268, 1910.097); applicable bulletins (FCC Bulletin 65 & IEEE C95.1, published in 1999); and the rules of any state agencies having jurisdiction.

5.2 Climbing Space

All facilities shall be installed in a manner that maintains adequate climbing space. The NESC defines the climbing space as a series of boxes 30 inches wide by 30 inches deep extending up the pole. See Figure 5 for more details.

5.3 Clearances

Local operations personnel may require a greater clearance distance to ensure that the approach distance is not compromised.

The following provides the minimum clearance from any part of the antenna to other equipment on the pole or ground surfaces. Refer to the latest copy of the NESC for other requirements or further detail:

1. Over the roadway, clearances shall exceed 16 feet.
2. Over driveways, parking lots, and alleys, clearances shall exceed 16 feet.
3. Over the pedestrian walkway, clearances shall exceed 12 feet.
4. Clearance to any supply wire shall be at least 48 inches.
5. Clearance to any other communications wire or equipment shall be 2 feet or more.
6. Horizontal clearance to pole surface shall be at least 2 feet.
7. The climbing space shall not be obstructed (see PacifiCorp Construction Standards *EU—Joint Use*).
8. Any antenna in the supply space shall be installed and maintained by workers authorized and qualified to work in the supply space.
9. All antennas shall be installed so as not to obstruct traffic control devices, signs, or vehicle sight lines.
10. No attachment method shall promote rust or decay of any kind to the pole or structure.
11. Some streetlights may have a wind rod attached above the arm. The wind rod must be considered part of the bracket-carrying luminaries as discussed in NESC rule 238C; therefore, clearances must be measured from this rod.

6 Checklist for Wi-Fi Attachments to PacifiCorp Facilities

Prior to attaching wi-fi devices to PacifiCorp facilities, the following must be provided to PacifiCorp's Joint Use department:

- Attachment Contract executed with PacifiCorp.
- All installation locations, including:
 - Pole number (from PacifiCorp pole plate);
 - Height of attachment;
 - Direction of any antennae (if applicable);
 - Address; and
 - Photographs of the top section of each pole showing streetlight and all attached wires/equipment.
- Employer's statement regarding qualification of employees performing installation (for installations in the supply space).
- Physical and electrical information, including:
 - Dimensions of device and antennae;
 - Weight;
 - Method of connecting to power source (e.g., photocell socket, etc.);
 - Maximum electrical demand in kW;
 - Voltage desired; and
 - Statement on size of RF field and worker-exposure limitations (include safe working distances and maximum exposure durations).
- Typical installation drawing or photo.
- Copies of applicable permits.

After PacifiCorp review:

- Corrections made either to the application or facilities in the field, if required by PacifiCorp.
- Receipt of Permit to Attach from PacifiCorp.

Post-Installation:

- Notification that installation is complete (to trigger post-installation inspection).
- Receipt of post-inspection results and required corrections.
- Receipt and payment of invoice for any billable work performed by PacifiCorp.

Maintenance:

- Any future pole attachments and/or equipment additions or replacements (where physical/electrical properties or location are altered) must be approved by the PacifiCorp Joint Use department.

7 Handbook Issuing Department

The Standards Engineering Documentation Department of PacifiCorp is responsible for issuing this document. Comments and suggestions are welcome. Additional copies may be obtained from:

Standards Engineering Documentation, Lloyd Center Tower
825 NE Multnomah St., Suite 1600, Portland, Oregon 97232
Telephone: (503) 813-5293 Fax: (503) 813-6804

Technical questions regarding the content of this document may be directed to PacifiCorp Standards Engineering, (503) 813-6883. Publication and use of this document is authorized by the Manager of Standards Engineering when the block below has been signed.

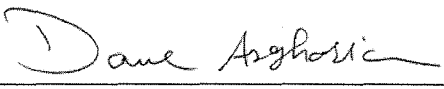
Approved: 
Dave Asgharian
Standards Engineering

Approved: 
Greg Lyons, Manager
Standards Engineering and Technology Development



Pacific Power |
Rocky Mountain Power
825 NE Multnomah
Portland, Oregon 97232

Information regarding wood pole inspection tagging

January 10, 2012

Dear Licensee,

This letter provides information regarding PacifiCorp's wood pole inspection program, specifically PacifiCorp's policy for tagging poles.

PacifiCorp's wood poles are inspected periodically and tested via sounding and boring and/or partial or full excavation. Upon completion of the inspection and tests, the poles are designated as Satisfactory, Reject/Reinforceable, or Reject/Replace and tags are placed on the poles in accordance with PacifiCorp's policy. Examples of the pole tags used in PacifiCorp's program are shown and explained on the enclosed attachment 1.

While PacifiCorp is providing this information to Licensee's whose employees and contractors work on or in the vicinity of PacifiCorp's poles, please note that such parties should not rely on the information but should perform their own assessment prior to performing work on or near a PacifiCorp pole. PacifiCorp is providing the information as a courtesy, but does not warrant or represent its accuracy.

Feel free to contact me with any questions.

Respectfully,

Jeffrey M. Kent
PacifiCorp
Director Distribution Support – Joint Use
503-813-7157
Jeffrey.Kent@PacifiCorp.corp

Enclosure: Attachment 1

ATTACHMENT 1

Caution: Any pole with 1 or 2 reject tags (a white or yellow rectangular tag) should not be climbed

