

**POWER PURCHASE AGREEMENT  
(RENEWABLE ENERGY – SOLAR)**

**BETWEEN**

**UTAH RED HILLS RENEWABLE PARK, LLC**

**AND**

**PACIFICORP**

TABLE OF CONTENTS

	Page
<b>Table of Contents</b>	
	<b>Page</b>
<b>SECTION 1 DEFINITIONS, RULES OF INTERPRETATION.....</b>	<b>2</b>
1.1    Defined Terms .....	2
1.2    Rules of Interpretation .....	14
1.2.1    General.....	14
1.2.2    Terms Not to be Construed For or Against Either Party .....	14
1.2.3    Headings .....	14
1.2.4    Examples.....	14
1.2.5    Interpretation with FERC Orders.....	14
<b>SECTION 2 TERM; FACILITY DEVELOPMENT .....</b>	<b>15</b>
2.1    Term; Inter-jurisdictional Cost Allocation.....	15
2.2    Adverse Order.....	15
2.3    Milestones .....	15
2.4    Project Construction and Delay Damages .....	16
2.5    Damages Calculation .....	17
2.6    Damages Invoicing .....	17
2.7    PacifiCorp’s Right to Monitor .....	18
2.8    Tax Credits.....	19
<b>SECTION 3 REPRESENTATIONS AND WARRANTIES .....</b>	<b>19</b>
3.1    Mutual Representations and Warranties .....	19
3.1.1    Organization.....	19
3.1.2    Authority.....	19
3.1.3    Corporate Actions .....	19
3.1.4    No Contravention.....	19
3.1.5    Valid and Enforceable Agreement.....	19
3.1.6    Litigation.....	20
3.2    Seller’s Further Representations and Warranties.....	20
3.2.1    Authority.....	20

**TABLE OF CONTENTS**

(continued)

	<b>Page</b>
3.2.2 No Contravention.....	20
3.2.3 Required Facility Documents .....	20
3.2.4 Delivery of Energy.....	21
3.2.5 Control of Premises.....	21
3.2.6 Undertaking of Agreement; Professionals and Experts .....	21
3.2.7 Verification .....	21
3.3 No Other Representations or Warranties .....	21
3.4 Continuing Nature of Representations and Warranties; Notice.....	21
<b>SECTION 4 DELIVERIES OF NET OUTPUT .....</b>	<b>22</b>
4.1 Purchase and Sale .....	22
4.2 No Sales to Third Parties .....	22
4.3 Title and Risk of Loss of Net Output.....	22
4.4 .....	22
4.5 PacifiCorp as Merchant.....	23
4.6 Title to Green Tags .....	23
4.6.1 Purchase and Sale of Capacity Rights .....	23
4.6.2 Representation Regarding Ownership of Capacity Rights .....	23
4.6.3 Further Assurances.....	23
<b>SECTION 5 CONTRACT PRICE; COSTS.....</b>	<b>23</b>
5.1 Contract Price; Includes Capacity Rights .....	23
5.1.1 Test Energy and Net Output Before Later of Commercial Operation Date and Scheduled Commercial Operation Date .....	23
5.1.2 Net Output After The Later of Commercial Operation Date and Scheduled Commercial Operation Date.....	24
5.2 Costs and Charges.....	24
5.3 Station Service .....	24
5.4 Taxes .....	24
5.5 Costs of Ownership and Operation .....	24
5.6 Rates Not Subject to Review .....	25
<b>SECTION 6 OPERATION AND CONTROL .....</b>	<b>25</b>
6.1 As-Built Supplement.....	25

**TABLE OF CONTENTS**

(continued)

	<b>Page</b>
6.2 Standard of Facility Operation.....	25
6.2.1 General.....	25
6.2.2 Qualified Operator.....	25
6.2.3 Fines and Penalties.....	26
6.3 Interconnection.....	26
6.4 Coordination with System.....	26
6.5 Outages.....	26
6.5.1 Planned Outages.....	26
6.5.2 Maintenance Outages.....	27
6.5.3 Forced Outages.....	27
6.5.4 Notice of Deratings and Outages.....	27
6.5.5 Effect of Outages on Estimated Output.....	27
6.6 Scheduling.....	28
6.6.1 Cooperation and Standards.....	28
6.6.2 Schedule Coordination.....	28
6.7 Forecasting.....	28
6.7.1 Long-Range Forecasts.....	28
6.7.2 Day-Ahead Forecasts and Updates.....	28
6.7.3 Basis of Forecasts.....	28
6.8 Increase in Nameplate Capacity Rating; New Project Expansion or Development.....	29
6.9 Electronic Communications.....	29
6.9.1 Telemetry.....	29
6.9.2 Transmission Provider Consent.....	29
6.9.3 Dedicated Communication Circuit.....	29
6.10 Reports and Records.....	30
6.10.1 Quarterly Reports.....	30
6.10.2 Electronic Fault Log.....	30
6.10.3 Other Information to be Provided to PacifiCorp.....	30
6.10.4 Information to Governmental Authorities.....	30
6.10.5 Data Request.....	31

**TABLE OF CONTENTS**

(continued)

	<b>Page</b>
6.10.6 Documents to Governmental Authorities .....	31
6.10.7 Environmental Information.....	31
6.10.8 Operational Reports .....	31
6.10.9 Notice of Material Adverse Events.....	32
6.10.10 Notice of Litigation.....	32
6.10.11 Additional Information .....	32
6.10.12 Confidential Treatment .....	32
6.11 Financial and Accounting Information .....	32
6.12 Output Guarantee .....	33
6.12.1 Output Guarantee .....	33
6.12.2 Liquidated Damages for Output Shortfall.....	33
6.12.3 Annual Invoicing .....	34
6.13 Access Rights.....	34
6.14 Facility Images.....	34
6.15 Installation of Additional Equipment.....	35
<b>SECTION 7 QUALIFYING FACILITY STATUS .....</b>	<b>35</b>
7.1 Seller’s QF Status .....	35
7.2 QF Facility .....	35
<b>SECTION 8 SECURITY AND CREDIT SUPPORT .....</b>	<b>35</b>
8.1 Project Development Security .....	35
8.1.1 Form and Amount of Project Development Security .....	35
8.1.2 Use of Project Development Security to Pay Delay Damages .....	36
8.1.3 Termination of Project Development Security .....	36
8.2 Default Security .....	36
8.2.1 Duty to Post Default Security .....	36
8.2.2 Amount of Default Security.....	36
8.3 Levelized Security .....	37
8.3.1 Duty to Post Levelized Security .....	37
8.3.2 Amount of Levelized Security .....	37
8.3.3 Duty of Levelized Security to Pay Amounts Due to PacifiCorp .....	37

**TABLE OF CONTENTS**

(continued)

	<b>Page</b>
8.4 Step In Rights.....	37
8.4.1 Failure to Achieve Commercial Operation.....	37
8.4.2 License to Operate Facility.....	37
8.4.3 Sole Remedy.....	38
8.4.4 Rights of Lenders.....	38
8.4.5 Indemnification; Standard of Care.....	38
8.4.6 Records and Access.....	38
8.4.7 Return.....	39
8.4.8 No Assumption.....	39
8.4.9 Costs and Expenses.....	39
8.5 Annual Financial Statements.....	39
8.6 Security is Not a Limit on Seller’s Liability.....	39
8.7 Senior Lender Protective Provisions.....	40
<b>SECTION 9 METERING.....</b>	<b>40</b>
9.1 Installation of Metering Equipment.....	40
9.2 Metering.....	40
9.3 Inspection, Testing, Repair and Replacement of Meters.....	40
9.4 Metering Costs.....	40
9.5 Meter Data.....	40
9.6 WREGIS Metering.....	41
<b>SECTION 10 BILLINGS, COMPUTATIONS AND PAYMENTS.....</b>	<b>41</b>
10.1 Monthly Invoices.....	41
10.2 Offsets.....	41
10.3 Interest on Late Payments.....	41
10.4 Disputed Amounts.....	41
10.5 Audit Rights.....	41
<b>SECTION 11 DEFAULTS AND REMEDIES.....</b>	<b>42</b>
11.1 Defaults.....	42
11.1.1 Defaults by Either Party.....	42
11.1.2 Defaults by Seller.....	42

**TABLE OF CONTENTS**

(continued)

	<b>Page</b>
11.2 Remedies for Failure to Deliver/Receive.....	43
11.2.1 Remedy for Seller’s Failure to Deliver.....	43
11.2.2 Remedy for PacifiCorp’s Failure to Purchase .....	44
11.2.3 Remedy for Seller’s Failure to Sell/Deliver Capacity Rights.....	44
11.3 Termination and Remedies .....	44
11.4 Termination of Duty to Buy.....	45
11.5 Termination Damages.....	46
11.6 Duty/Right to Mitigate.....	46
11.7 Security .....	46
11.8 Cumulative Remedies .....	46
<b>SECTION 12 INDEMNIFICATION AND LIABILITY .....</b>	<b>46</b>
12.1 Indemnities.....	46
12.1.1 Indemnity by Seller.....	46
12.1.2 Indemnity by PacifiCorp.....	47
12.1.3 Additional Cross Indemnity .....	47
12.1.4 No Dedication .....	47
12.1.5 Consequential Damages.....	47
<b>SECTION 13 INSURANCE.....</b>	<b>48</b>
13.1 Required Policies and Coverages.....	48
<b>SECTION 14 FORCE MAJEURE.....</b>	<b>48</b>
14.1 Definition of Force Majeure .....	48
14.2 Suspension of Performance.....	48
14.3 Force Majeure Does Not Affect Other Obligations .....	49
14.4 Strikes .....	49
14.5 Right to Terminate .....	49
<b>SECTION 15 SEVERAL OBLIGATIONS .....</b>	<b>49</b>
<b>SECTION 16 CHOICE OF LAW .....</b>	<b>49</b>
<b>SECTION 17 PARTIAL INVALIDITY .....</b>	<b>50</b>
<b>SECTION 18 NON-WAIVER .....</b>	<b>50</b>
<b>SECTION 19 GOVERNMENTAL JURISDICTION AND AUTHORIZATIONS .....</b>	<b>50</b>

TABLE OF CONTENTS

(continued)

	<b>Page</b>
<b>SECTION 20 SUCCESSORS AND ASSIGNS .....</b>	<b>50</b>
20.1 Restriction on Assignments .....	50
20.2 Permitted Assignments .....	50
<b>SECTION 21 ENTIRE AGREEMENT .....</b>	<b>51</b>
<b>SECTION 22 NOTICES .....</b>	<b>51</b>
22.1 Addresses and Delivery Methods .....	51
22.2 Changes of Address .....	52
22.3 Notices to Senior Lenders .....	52
<b>SECTION 23 CONFIDENTIALITY .....</b>	<b>52</b>
23.1 Confidential Business Information .....	52
23.2 Duty to Maintain Confidentiality .....	53
23.3 PacifiCorp Regulatory Compliance .....	53
23.4 Irreparable Injury; Remedies .....	53
23.5 News Releases and Publicity .....	54
<b>SECTION 24 DISAGREEMENTS .....</b>	<b>54</b>
24.1 Negotiations .....	54
24.2 Arbitration .....	54
24.3 Additional Legal Remedies .....	54
24.4 Place of Contract Formation; Choice of Forum .....	54
24.5 Settlement Discussions .....	55
24.6 Waiver of Jury Trial .....	55



**EXHIBITS**

- Exhibit A Estimated Monthly Output
- Exhibit B NERC Event Types
- Exhibit C Example Calculation of Delay Damages
- Exhibit D Start-Up Testing
- Exhibit E Example Calculation of PacifiCorp’s Cost to Cover
- Exhibit F Sample Report From Firm Market Price Index
- Exhibit G Approved Licensed Professional Engineers
- Exhibit 2.7 PacifiCorp’s Initial Designated Representatives
- Exhibit 3.2.3 Required Facility Documents
- Exhibit 3.2.6 Leases
- Exhibit 5.1 Contract Price
  - Exhibit 5.1.1 Scaling Factor
- Exhibit 6.1 Description of Facility and Premises
  - Exhibit 6.12.2 Example Calculation of Liquidated Damages For an Output Shortfall
- Exhibit 8.2.1 Form of Guaranty
- 
- Exhibit 9.2 Point of Delivery/Interconnection Facilities
- Exhibit 9.5 Seller Authorization to Release Generation Data to PacifiCorp
- Exhibit 13 Required Insurance

**POWER PURCHASE AGREEMENT  
(RENEWABLE ENERGY)**

THIS POWER PURCHASE AGREEMENT (RENEWABLE ENERGY) (this “Agreement”), is entered into between Utah Red Hills Renewable Park, LLC a Delaware limited liability company (“Seller”) and PacifiCorp, an Oregon corporation acting in its merchant function capacity (“PacifiCorp”). Seller and PacifiCorp are sometimes hereinafter referred to collectively as the “Parties” and individually as a “Party.”

**RECITALS**

WHEREAS, Seller intends to construct, own, operate and maintain a solar-powered generation facility for the generation of electric energy located in Iron County, Utah with an expected nameplate capacity rating of [REDACTED] (AC) (the “Facility”).

WHEREAS, Seller intends to operate the Facility as a Qualifying Facility (“QF”).

WHEREAS, Seller expects that the Facility will deliver to PacifiCorp [REDACTED] MWh of Net Output per calendar year. Seller estimates that the Net Output will be delivered during each calendar year according to the estimates of monthly output set forth in Exhibit A. Seller acknowledges that PacifiCorp will include this amount of energy in PacifiCorp’s resource planning.

WHEREAS, Seller desires to sell, and PacifiCorp desires to purchase, the Net Output expected to be delivered by the Facility in accordance with the terms and conditions hereof.

WHEREAS, the rates, terms and conditions in this Agreement are in accordance with the rates, terms, and conditions approved by the Commission for purchases from Qualifying Facilities.

WHEREAS, the rates, terms and conditions in this Agreement are in accordance with the rates, terms, and conditions approved by the Commission in Docket No. 03-035-14 and Docket No. 12-035-100 for purchases from Qualifying Facilities.

WHEREAS, PacifiCorp intends to designate Seller’s Facility as a Network Resource for the purposes of serving network load.

WHEREAS, for purposes of inter-jurisdictional cost allocation, this Agreement is a “New QF Contract” under the PacifiCorp Inter-Jurisdictional Cost Allocation Revised Protocol (“Revised Protocol”) and, as such, its costs are allocated as a system resource unless any portion of the cost of this Agreement exceeds the cost PacifiCorp would have otherwise incurred acquiring comparable resources, in which case such excess costs shall be assigned on a situs basis.

WHEREAS, Seller shall obtain any necessary retail electric service from PacifiCorp pursuant to the applicable PacifiCorp retail electric service schedule.

NOW, THEREFORE, in consideration of the foregoing and the mutual promises set forth below and for other good and valuable consideration, the receipt and sufficiency of which are hereby acknowledged, the Parties mutually agree as follows:

**A G R E E M E N T**

**SECTION 1  
DEFINITIONS, RULES OF INTERPRETATION**

1.1 Defined Terms. Unless otherwise required by the context in which any term appears, initially capitalized terms used herein shall have the following meanings:

“AAA” means the American Arbitration Association.

“AC” means alternating current.

“Abandonment” means (a) the relinquishment of all possession and control of the Facility by Seller, other than pursuant to a transfer permitted under this Agreement, or (b) if after commencement of the construction, testing, and inspection of the Facility, and prior to the Commercial Operation Date, there is a complete cessation of the construction, testing, and inspection of the Facility for ninety (90) consecutive days by Seller and Seller’s contractors, but only if such relinquishment or cessation is not caused by or attributable to an Event of Default of, or request by, PacifiCorp, or an event of Force Majeure.

“Affiliate” means, with respect to any entity, each entity that directly or indirectly controls, is controlled by, or is under common control with, such designated entity, with “control” meaning the possession, directly or indirectly, of the power to direct management and policies, whether through the ownership of voting securities or by contract or otherwise. Notwithstanding the foregoing, with respect to PacifiCorp, Affiliate shall only include MidAmerican Energy Holdings Company and its direct, wholly owned subsidiaries.

“Agreement” is defined in the Recitals.

“As-built Supplement” is a supplement to be added to Exhibit 6.1 that describes the Facility as actually built, pursuant to Section 6.1 and includes an American Land Title Association survey of the Premises.

“Business Day” means any day on which banks in Salt Lake City, Utah are not authorized or required by Requirements of Law to be closed, beginning at 6:00 a.m. and ending at 5:00 p.m. local time in Utah.

“Capacity Rights” means any current or future defined characteristic, certificate, tag (but not Green Tags), credit, ancillary service or attribute thereof, or accounting construct, including any of the same counted towards any current or future resource adequacy or reserve requirements, associated with the electric generation capability and capacity of the Facility or the Facility’s capability and ability to produce energy. Capacity Rights are measured in MW and do not include ITCs, any Tax Credits, or any other tax incentives existing now or in the future associated with the construction, ownership or operation of the Facility.

“Commercial Operation” means that not less than the Required Percentage of the Expected Nameplate Capacity Rating of the Facility is fully operational and reliable and the Facility is fully interconnected, fully integrated, and synchronized with the System, all of which shall be Seller’s responsibility to receive or obtain, and which occurs when all of the following events (a) have occurred, and (b) remain simultaneously true and accurate as of the date and moment on which Seller gives PacifiCorp notice that Commercial Operation has occurred:

(i) PacifiCorp shall have received a certificate addressed to PacifiCorp from one of the Licensed Professional Engineers listed on Exhibit G, or such other Licensed Professional Engineer mutually agreed upon by the parties, stating: (1) the Nameplate Capacity Rating of the Facility at the anticipated time of Commercial Operation, of at least the Required Percentage of the Expected Nameplate Capacity Rating, and (2) that the Facility is able to generate electric energy reliably in amounts expected by this Agreement and in accordance with all other terms and conditions hereof; and, (3) Start-Up Testing of the Facility has been completed;

(ii) PacifiCorp shall have received a certificate addressed to PacifiCorp from a Licensed Professional Engineer stating that, in accordance with the Generation Interconnection Agreement, all required Interconnection Facilities have been constructed, all required interconnection tests have been completed and the Facility is physically interconnected with the System in conformance with the Generation Interconnection Agreement and able to deliver energy consistent with the terms of this Agreement.

(iii) PacifiCorp shall have received a certificate from a Licensed Professional Engineer or an opinion from an attorney licensed in the state of Utah that is not an employee of Seller (or any affiliate, parent or subsidiary) and has no financial interest in the Facility addressed to PacifiCorp stating that Seller has obtained or entered into all Required Facility Documents. Seller shall provide copies of any or all Required Facility Documents requested by PacifiCorp.

(iv) PacifiCorp has received confirmation from the Transmission Provider that the Facility has been designated as a Network Resource and PacifiCorp has received confirmation from the Transmission Provider that the transmission service request has been granted in sufficient capacity to meet or exceed the Maximum Delivery Rate and the Seller has paid all costs associated with any requirements of the transmission service request.

Seller shall provide written notice to PacifiCorp stating when Seller believes that the Facility has achieved Commercial Operation and its Nameplate Capacity Rating accompanied by the certificates described above. PacifiCorp shall have ten (10) Business Days after receipt either to confirm to Seller that all of the conditions to Commercial Operation have been satisfied or have occurred, or to state with specificity what PacifiCorp reasonably believes has not been satisfied. If, within such 10-Business Day period, PacifiCorp does not respond or notifies Seller confirming that the Facility has achieved Commercial Operation, the original date of receipt of Seller’s notice shall be the Commercial Operation Date. If PacifiCorp notifies Seller within such 10-Business Day period that PacifiCorp reasonably believes the Facility has not achieved Commercial Operation, Seller shall address the concerns stated in PacifiCorp’s notice to the satisfaction of PacifiCorp. In the event PacifiCorp provides notice of deficiency with regards to

the information submitted to establish the Commercial Operation Date, then the Commercial Operation Date shall be the date upon which Seller has addressed the concerns stated in PacifiCorp's notice to PacifiCorp's reasonable satisfaction. If Commercial Operation is achieved at less than 100 percent of the Expected Nameplate Capacity Rating and Seller informs PacifiCorp that Seller intends to bring the Facility to 100 percent of the Expected Nameplate Capacity Rating, Seller shall provide PacifiCorp with a list of all items to be completed in order to achieve Final Completion ("Final Completion Punch List"). All items on the Final Completion Punch List must be completed on or before the 90th day after the Commercial Operation Date; *provided, however*, that if at any time on or before the last day of such period Seller determines not to increase the Facility's Nameplate Capacity Rating, Seller may provide written notice to PacifiCorp that the Facility has achieved Final Completion at the Facility's current Nameplate Capacity Rating, whether or not all of the items on the Final Completion Punch List have been completed.

"Commercial Operation Date" means the date that Commercial Operation is achieved for the Facility but in no event earlier than thirty (30) calendar days before the Scheduled Commercial Operation Date.

"Commission" means the Utah Public Service Commission.

"Confidential Business Information" is defined in Section 23.1.

"Contract Interest Rate" means the lesser of (a) the highest rate permitted under Requirements of Law or (b) 200 basis points per annum plus the rate per annum equal to the publicly announced prime rate or reference rate for commercial loans to large businesses in effect from time to time quoted by Citibank, N.A. as its "prime rate." If a Citibank, N.A. prime rate is not available, the applicable prime rate shall be the announced prime rate or reference rate for commercial loans in effect from time to time quoted by a bank with \$10 billion or more in assets in New York City, New York, selected by the Party to whom interest is being paid.

"Contract Price" means the applicable price, expressed in \$/MWh for Net Output and Capacity Rights stated in Section 5.1.

"Contract Year" means any consecutive 12-month period during the Term, commencing at 00:00 hours on the Commercial Operation Date or any of its anniversaries and ending at 24:00 hours on the last day of such 12-month period.

"Credit Requirements" means a senior, unsecured long term debt rating (or corporate rating if such debt rating is unavailable) of (a) BBB- or greater from S&P, or (b) Baa3 or greater from Moody's; provided that if (a) or (b) is not available, an equivalent rating as determined by PacifiCorp through an internal process review and utilizing a proprietary credit scoring model developed in conjunction with a third party.

"Default Security" is defined in Section 8.2.1.

"Delay Damages" for any given day are equal to (a) the Expected Energy, expressed in MWhs per year, divided by 365, multiplied by (b) PacifiCorp's Cost to Cover.

“Effective Date” is defined in Section 2.1.

“Electric System Authority” means each of NERC, WECC, WREGIS, and RTO, a regional or sub-regional reliability council or authority, and any other similar council, corporation, organization or body of recognized standing with respect to the operations of the electric system in the WECC region, as such are applicable to the Seller or PacifiCorp.

“Environmental Attributes” means any and all claims, credits, benefits, emissions reductions, offsets, and allowances, howsoever entitled, resulting from the avoidance of the emission of any gas, chemical, or other substance to the air, soil or water. Environmental Attributes include but are not limited to: (a) any avoided emissions of pollutants to the air, soil, or water such as (subject to the foregoing) sulfur oxides (SO<sub>x</sub>), nitrogen oxides (NO<sub>x</sub>), carbon monoxide (CO), and other pollutants; and (b) any avoided emissions of carbon dioxide (CO<sub>2</sub>), methane (CH<sub>4</sub>), and other greenhouse gases (GHGs) that have been determined by the United Nations Intergovernmental Panel on Climate Change to contribute to the actual or potential threat of altering the Earth’s climate by trapping heat in the atmosphere. Environmental Attributes do not include (i) ITCs or any Tax Credits, or certain other tax incentives existing now or in the future associated with the construction, ownership or operation of the Facility, (ii) matters designated by PacifiCorp as sources of liability, or (iii) adverse wildlife or environmental impacts.

“Environmental Contamination” means the introduction or presence of Hazardous Materials at such levels, quantities or location, or of such form or character, as to constitute a violation of federal, state or local laws or regulations, and present a material risk under federal, state or local laws and regulations that the Premises will not be available or usable for the purposes contemplated by this Agreement.

“Event of Default” is defined in Section 11.1.

“Example” means an example of certain calculations to be made hereunder. Each Example is for purposes of illustration only and is not intended to constitute a representation, warranty or covenant concerning the matters assumed for purposes of each Example.

“Expected Energy” means [REDACTED] of Net Output per year measured at the Point of Delivery, which is Seller’s best estimate of the projected long-term average annual Net Output production based upon typical solar conditions at the Facility as determined by a Solar Performance Modeling Program, delivered to the Point of Delivery and the Expected Nameplate Capacity Rating. Seller estimates that the Net Output will be delivered during each calendar year according to the estimates of monthly output set forth in Exhibit A. If at Final Completion the Facility’s Nameplate Capacity Rating is less than the Expected Nameplate Capacity Rating, Expected Energy shall be reduced or prorated by [REDACTED] per year for each full MW of Nameplate Capacity Rating below the Expected Nameplate Capacity Rating. Seller acknowledges that PacifiCorp will include Expected Energy in PacifiCorp’s resource planning. PacifiCorp acknowledges that solar exposure is a variable resource and that the Facility’s actual annual output of Net Output in the ordinary course in any given year will be subject to variation caused by differences in the actual solar exposure at the Facility from year to year.

“Expected Nameplate Capacity Rating” means [REDACTED] the expected maximum instantaneous generation capacity of the Facility.

“Expected Output” means [REDACTED] in the first full Contract Year, reduced by an annual degradation factor of [REDACTED] per Contract Year.

“Facility” is defined in the Recitals and is more fully described in attached Exhibit 6.1 and includes the photovoltaic power generating equipment, including panels and inverters, and all other equipment, devices, associated appurtenances owned, controlled, operated and managed by Seller in connection with, or to facilitate, the production, generation, transmission, delivery, or furnishing of electric energy by Seller to PacifiCorp and required to interconnect with the System.

“Facility Financing Date” means the closing date for the construction financing for the Facility between Seller or Seller’s Affiliates and a Lender.

“FERC” means the Federal Energy Regulatory Commission.

“Final Completion” means the Facility is fully operational and reliable, at or greater than the Required Percentage of the Expected Nameplate Capacity Rating, and fully interconnected, fully integrated, and synchronized with the Transmission Provider’s System, as evidenced (to the reasonable satisfaction of PacifiCorp) by the completion of all items set forth on the Final Completion Punch List or by Seller’s written notice to PacifiCorp that the Facility has achieved Final Completion, modified if necessary to reflect the Nameplate Capacity Rating.

“Final Completion Punch List” is defined in the definition of “Commercial Operation.”

“Firm Market Price Index” means (a) 93 percent of the average price reported by Intercontinental Exchange, Inc. (“ICE”) Day-Ahead Palo Verde On-Peak Index, for On-Peak Hours, and (b) 93 percent of the average price reported on the ICE Day-Ahead Palo Verde Off-Peak Index, for Off-Peak Hours. If either index is not available for a given period, for purposes of calculations hereunder, the Firm Market Price Index shall be deemed to equal the volumetrically-weighted average price derived from data published by ICE for the same number of days immediately preceding and immediately succeeding the period in which the index in question was not available, regardless of which days of the week are used for this purpose. If the Firm Market Price Index or its replacement or any component of that index or its replacement ceases to be published or available, or useful for its intended purpose hereunder, during the Term, the Parties shall agree upon a replacement Firm Market Price Index or component an index or component that, after any necessary adjustments, provides the most reasonable substitute quotation of the daily price of electricity for the applicable periods.

“Force Majeure” is defined in Section 14.1.

“Forced Outage” means NERC Event Types U1, U2 and U3, as set forth in attached Exhibit B, and specifically excludes any Maintenance Outage or Planned Outage.

“Generation Interconnection Agreement” means the large generator interconnection agreement to be entered into separately between Seller and Interconnection Provider concerning the Interconnection Facilities.

“Governmental Authority” means any supranational, federal, state or other political subdivision thereof, having jurisdiction over Seller, PacifiCorp or this Agreement, including any municipality, township or county, and any entity or body exercising executive, legislative, judicial, regulatory or administrative functions of or pertaining to government, including any corporation or other entity owned or controlled by any of the foregoing.

“Green Tags” means (a) the Environmental Attributes associated with all Output, together with (b) the Green Tag Reporting Rights associated with such energy and Environmental Attributes, however commercially transferred or traded under any or other product names, such as “Renewable Energy Credits,” “Green-e Certified,” or otherwise. One Green Tag represents the Environmental Attributes made available by the generation of one MWh of energy from the Facility.

“Green Tag Reporting Rights” means the exclusive right of a purchaser of Environmental Attributes to report ownership of Environmental Attributes in compliance with federal or state law, if applicable, and to federal or state agencies or other parties at such purchaser’s discretion, and include reporting under Section 1605(b) of the Energy Policy Act of 1992, or under any present or future domestic, international, or foreign emissions trading program or renewable portfolio standard.

“Guaranteed Commercial Operation Date” means the date that is ninety (90) days after the Scheduled Commercial Operation Date.

“Hazardous Materials” means any waste or other substance that is listed, defined, designated or classified as or determined to be hazardous under or pursuant to any federal or state environmental law or regulation.

“Indemnified Party” is defined in Section 6.2.3(b).

“Interconnection Facilities” means all the facilities installed, or to be installed, for the purpose of interconnecting the Facility to the System, including electrical transmission lines, upgrades, transformers and associated equipment, substations, relay and switching equipment, and safety equipment.

“Interconnection Provider” means PacifiCorp Transmission.

“Inverter” means the equipment installed at the Facility to convert direct current from the Solar Panels to alternating current, as described in Exhibit 6.1.

“ITCs” means the investment tax credits established pursuant to Section 48 of the Internal Revenue Code, as such law may be amended or superseded.

“KW” means kilowatt.



“KWh” means kilowatt hour.

“Leases” means the memoranda of lease and redacted leases recorded in connection with the development of the Facility, as the same may be supplemented, amended, extended, restated, or replaced from time to time.

“Lender” means an entity lending money or extending credit (including any financing lease, monetization of tax benefits, transaction with a tax investor, backleverage financing or credit derivative arrangement) to Seller or Seller’s Affiliates (a) for the construction, term or permanent financing or refinancing of the Facility; (b) for working capital or other ordinary business requirements for the Facility (including for the maintenance, repair, replacement or improvement of the Facility); (c) for any development financing, bridge financing, credit support, and related credit enhancement or interest rate, currency, weather, or Environmental Attributes in connection with the development, construction or operation of the Facility; or (d) for the purchase of the Facility and related rights from Seller.

“Lender Consent” means a consent to collateral assignment in favor of one or more Lenders.

“Letter of Credit” means an irrevocable standby letter of credit in a form reasonably acceptable to PacifiCorp, naming PacifiCorp as the party entitled to demand payment and present draw requests thereunder that:

- (1) is issued by a Qualifying Institution;
- (2) by its terms, permits PacifiCorp to draw up to the face amount thereof for the purpose of paying any and all amounts owing by Seller hereunder;
- (3) if issued by a foreign bank with a United States branch, permits PacifiCorp to draw upon the United States branch;
- (4) permits PacifiCorp to draw the entire amount available thereunder if such letter of credit is not renewed or replaced at least thirty (30) Business Days prior to its stated expiration date;
- (5) permits PacifiCorp to draw the entire amount available thereunder if such letters of credit are not increased or replaced as and when provided in Section 8;
- (6) is transferable by PacifiCorp to any party to which PacifiCorp may assign this Agreement; and
- (7) shall remain in effect for at least ninety (90) days after the end of the Term.

“Levelized Security” is defined in Section 8.3.1.

“Liabilities” is defined in Section 12.1.1.

“Licensed Professional Engineer” means a person proposed by Seller and acceptable to PacifiCorp in its reasonable judgment who (a) to the extent mandated by Requirements of Law is licensed to practice engineering in the appropriate engineering discipline for the required certification being made, in the United States, and in all states for which the person is providing a certification, evaluation or opinion with respect to matters or Requirements of Law specific to such state, (b) has training and experience in the engineering disciplines relevant to the matters with respect to which such person is called upon to provide a certification, evaluation or opinion, (c) has no economic relationship, association, or nexus with Seller and is not an employee of its members or Affiliates, other than with the prior written consent of PacifiCorp, for services previously or currently being rendered to Seller or its members or Affiliates, and (d) is not a representative of a consulting engineer, contractor, designer or other individual involved in the development of the Facility, or of a manufacturer or supplier of any equipment installed in the Facility.

“Maintenance Outage” means NERC Event Type MO, as set forth in attached Exhibit B, and includes any outage involving 10 percent of the Facility’s Net Output that is not a Forced Outage or a Planned Outage.

“Maximum Delivery Rate” means the maximum hourly rate of delivery of Net Output in MWh from the Facility to the Point of Delivery, calculated on the basis of the Net Output delivered in an hour accruing at an average rate equivalent to the actual Nameplate Capacity Rating.

“Moody’s” means Moody’s Investor Services, Inc.

“Mountain Prevailing Time” or “MPT” means Mountain Standard Time or Mountain Daylight Time, as applicable in Utah on the day in question.

“MW” means megawatt.

“MWh” means megawatt hour.

“Nameplate Capacity Rating” means the maximum installed instantaneous generation capacity of the completed Facility, expressed in MW (AC), when operated in compliance with the Generation Interconnection Agreement and consistent with the recommended power factor and operating parameters provided by the manufacturer of the Solar Panels and Inverters, as set forth in a notice from Seller to PacifiCorp delivered prior to the Commercial Operation Date and, if applicable, updated in a subsequent notice from Seller to PacifiCorp as required for Final Completion. The Nameplate Capacity Rating of the Facility shall not exceed 80 MW.

“NERC” means the North American Electric Reliability Corporation.

“Net Output” means all energy and capacity produced by the Facility, less station use and less transformation and transmission losses and other adjustments (e.g., Seller’s load other than station use), if any. For purposes of calculating payment under this Agreement, Net Output of energy shall be the amount of energy flowing through the Point of Delivery.

“Network Resource” is defined in the Tariff.

“Network Service Provider” means PacifiCorp Transmission, as a provider of network service to PacifiCorp under the Tariff.

“Off-Peak Hours” means all hours ending 01:00:00 through 06:00:00 and hours ending 23:00:00 through 24:00:00, MPT, Monday through Saturday and hours ending 01:00:00 through 24:00:00, MPT, on Sundays and NERC designated holidays.

“On-Peak Hours” means all hours ending 07:00:00 through 22:00:00 MPT, Monday through Saturday, excluding NERC designated holidays.

“Output” means all energy produced by the Facility.

“Output Guarantee” is defined in Section 6.12.1.

“Output Shortfall” is defined in Section 6.12.2.

“PacifiCorp” is defined in the Recitals, and explicitly excludes PacifiCorp Transmission.

“PacifiCorp Indemnitees” is defined in Section 12.1.1.

“PacifiCorp Representatives” is defined in Section 6.13.

“PacifiCorp Transmission” means PacifiCorp, an Oregon corporation, acting in its interconnection or transmission function capacity.

“PacifiCorp’s Cost to Cover” means the positive difference, if any, between (a) the sum of the time weighted average of the Firm Market Price Index for each day for which the determination is being made, minus (b) the Contract Price specified in Exhibit 5.1 in effect on such days, stated as an amount per MWh. If on a given day (or Contract Year in the case of calculating Output Shortfall) the difference between (a) minus (b) referenced above is zero or negative, then PacifiCorp’s Cost to Cover shall be zero dollars (\$0), and Seller shall have no obligation to pay any amount to PacifiCorp on account of Section 6.12.2 or Section 11.2.1 with respect to such day (or Contract Year in the case of calculating Output Shortfall). For any days prior to the Commercial Operation Date, the Contract Price applicable in the first Contract Year shall be utilized for purposes of clause (b). For illustrative purposes only, Exhibit E sets forth an example calculation of Pacificorp’s Cost to Cover.

“Party” and “Parties” are defined in the Recitals.

“Permits” means the permits, licenses, approvals, certificates, entitlements and other authorizations issued by Governmental Authorities required for the construction, ownership and operation of the Facility and occupancy of the Premises, and all amendments, modifications, supplements, general conditions and addenda thereto.

“Planned Outage” means NERC Event Type PO, as set forth in attached Exhibit B, and specifically excludes any Maintenance Outage or Forced Outage.

“Point of Delivery” means the point of interconnection between the Facility and the System, as specified in the Generation Interconnection Agreement and as further described in Exhibit 9.2.

“Premises” means the real property on which the Facility is or will be located, as more fully described on Exhibit 6.1.

“Project Development Security” has the meaning given to that term in Section 8.1.1.

“Prudent Electrical Practices” means any of the practices, methods and acts engaged in or approved by a significant portion of the independent electric power generation industry for solar facilities of similar size and characteristics or any of the practices, methods or acts, which, in the exercise of reasonable judgment in the light of the facts known at the time a decision is made, could have been expected to accomplish the desired result at the lowest reasonable cost consistent with reliability, safety and expedition. Prudent Electrical Practices is not intended to be limited to the optimum practice, method or act to the exclusion of all others, but rather to be a spectrum of possible practices, methods or acts generally accepted in the industry.

“PUHCA” means the Public Utility Holding Company Act of 2005.

“PURPA” means the Public Utility Regulatory Policies Act of 1978.

“QF” means “Qualifying Facility,” as that term is defined in the FERC regulations (codified at 18 CFR Part 292) in effect on the Effective Date.

“Qualifying Institution” means the United States office of a commercial bank or trust company organized under the laws of the United States of America or a political subdivision thereof, or a foreign bank, having assets \$10,000,000,000 (net of reserves) and a credit rating on its long-term senior unsecured debt of at least “A” from S&P and “A2” from Moody’s.

“Reporting Quarter” is defined in Section 6.10.1.

“Required Facility Documents” means the Permits and other authorizations, rights and agreements now or hereafter necessary for construction, operation, and maintenance of the Facility. Seller shall set forth all the Required Facility Documents in Exhibit 3.2.3.

“Required Percentage” means 90 percent.

“Requirements of Law” means any applicable and mandatory (but not merely advisory) federal, state and local law, statute, regulation, rule, action, order, code or ordinance enacted, adopted, issued or promulgated by any federal, state, local or other Governmental

Authority or regulatory body (including those pertaining to electrical, building, zoning, environmental and occupational safety and health requirements).

“Rolling Period” is defined in Section 6.12.1.

“RTO” means any entity (including, but not limited to an independent system operator) that becomes responsible as system operator for, or directs the operation of, the System.

“S&P” means Standard & Poor’s Rating Group (a division of McGraw-Hill, Inc.).

“Schedule 37” means Rocky Mountain Power Electric Service Schedule No. 37 as attached in Exhibit 5.1, and as approved by the Commission.

“Scheduled Commercial Operation Date” means December 31, 2016.

“Seller” is defined in the Recitals.

“Seller Indemnitees” is defined in Section 12.1.2.

“Seller’s Cost to Cover” means the positive difference, if any, between (a) the Contract Price per MWh specified in Exhibit 5.1, and (b) the net proceeds per MWh actually realized by Seller from the sale to a third party of Net Output not purchased by PacifiCorp as required hereunder. If on any given day the difference between (a) minus (b) referenced above is zero or negative, then Seller’s Cost to Cover shall be zero dollars with respect to such day, and PacifiCorp shall have no obligation to pay any amount to Seller on account of Section 11.2.2. For any days prior to the Commercial Operation Date, the Contract Price applicable in the first Contract Year shall be utilized for purposes of clause (a).

“Senior Lenders” means Lenders being granted senior security interests on the Facility or its assets, or Seller or its equity, other than Affiliates of Seller.

“Seller Uncontrollable Minutes” means, for the Facility in any Contract Year, the total number of minutes during such Contract Year during which the Facility was unable to deliver Net Output to PacifiCorp (or during which PacifiCorp failed to accept such delivery) due to one or more of the following events, each as recorded by Seller’s SCADA and indicated by Seller’s electronic fault log: (a) an emergency or Force Majeure event; (b) to the extent not caused by Seller’s actions, a curtailment in accordance with Section 4.4(b); (c) the System operating outside the voltage or frequency limits defined in the applicable operating manual for the Inverters installed at the Facility; (d) Planned Outages, but in no event exceeding one hundred twenty (120) hours per Contract Year consistent with such operating manual; and (e) a default by PacifiCorp; provided, however, that if any of the events described above in items (a) through (e) occur simultaneously, then the relevant period of time shall only be counted once in order to prevent double counting. Seller Uncontrollable Minutes shall not include minutes when (i) the Facility or any portion thereof was unavailable solely due to Seller’s non-conformance with the Generation Interconnection Agreement or (ii) the Facility or any portion thereof was paused or withdrawn from use by Seller for reasons other than those covered in this definition.

“Solar Array” means one or more Solar Panels connected to the same Inverter.

“Solar Panels” means the photovoltaic energy generating panels installed at the Facility as described in Exhibit 6.1.

“Solar Performance Modeling Program” means a commercially available computer modeling program that is generally accepted in the solar energy industry capable of modeling the Expected Energy and other similar outputs. Solar Performance Modeling Program includes, but is not limited to, the PVSYST program. If Seller selects a Solar Performance Modeling Program that PacifiCorp does not have access to, Seller, at its cost, shall provide PacifiCorp access to the Solar Performance Modeling Program in order for PacifiCorp to fully analyze all modeling provided by Seller under this Agreement.

“Start-Up Testing” means the start-up tests for the Facility as set forth in Exhibit D.

“Step-In Rights” is defined in Section 8.4.2.

“System” means the electric transmission substation and transmission or distribution facilities owned, operated or maintained by Transmission Provider, which shall include, after construction and installation of the Facility, the circuit reinforcements, extensions, and associated terminal facility reinforcements or additions required to interconnect the Facility, all as set forth in the Generation Interconnection Agreement.

“Tariff” means the PacifiCorp FERC Electric Tariff Fifth Revised Volume No. 11 Pro Forma Open Access Transmission Tariff, as revised from time to time.

“Tax Credits” means any state, local and/or federal production tax credit, tax deduction, and/or investment tax credit specific to the production of renewable energy and/or investments in renewable energy facilities.

“Term” is defined in Section 2.1.

“Test Energy” means any Net Output during periods prior to the Commercial Operation Date and related Capacity Rights.

“Transmission Provider” means PacifiCorp Transmission, including the grid operations business unit.

“Transmission Service” means, if applicable, the transmission services pursuant to which the Transmission Provider transmits Output to the Point of Delivery, as applicable.

“WECC” means the Western Electricity Coordinating Council.

“WREGIS” means the Western Renewable Energy Generation Information System.

1.2 Rules of Interpretation.

1.2.1 General. Unless otherwise required by the context in which any term appears, (a) the singular includes the plural and vice versa; (b) references to “Articles,” “Recitals,” “Sections,” “Schedules,” “Annexes,” “Appendices” or “Exhibits” are to articles, recitals, sections, schedules, annexes, appendices or exhibits hereof; (c) all references to a particular entity or an electricity market price index include a reference to such entity’s or index’s successors; (d) “herein,” “hereof” and “hereunder” refer to this Agreement as a whole; (e) all accounting terms not specifically defined herein shall be construed in accordance with generally accepted accounting principles, consistently applied; (f) the masculine includes the feminine and neuter and vice versa; (g) “including” means “including, without limitation” or “including, but not limited to”; (h) all references to a particular law or statute mean that law or statute as amended from time to time; (i) all references to energy or capacity are to be interpreted as utilizing alternating current, unless expressly stated otherwise; and (j) the word “or” is not necessarily exclusive. Reference to “days” shall be calendar days, unless expressly stated otherwise herein.

1.2.2 Terms Not to be Construed For or Against Either Party. Each term hereof shall be construed simply according to its fair meaning and not strictly for or against either Party. The Parties have jointly prepared this Agreement, and no term hereof shall be construed against a Party on the ground that the Party is the author of that provision.

1.2.3 Headings. The headings used for the sections and articles hereof are for convenience and reference purposes only and shall in no way affect the meaning or interpretation of the provisions hereof.

1.2.4 Examples. Example calculations and other examples set forth herein are for purposes of illustration only and are not intended to constitute a representation, warranty or covenant concerning the example itself or the matters assumed for purposes of such example. If there is a conflict between an example and the text hereof, the text shall control.

1.2.5 Interpretation with FERC Orders. Each Party conducts and shall conduct its operations in a manner intended to comply with FERC Order No. 2004, Standards of Conduct for Transmission Providers, requiring the separation of its transmission and merchant functions. Moreover, the Parties acknowledge that Interconnection Provider’s transmission function offers transmission service on its system in a manner intended to comply with FERC policies and requirements relating to the provision of open-access transmission service. The Parties recognize that Seller will enter into the Generation Interconnection Agreement with the Interconnection Provider.

(a) The Parties acknowledge and agree that the Generation Interconnection Agreement shall be a separate and free standing contract and that the terms hereof are not binding upon the Interconnection Provider.

(b) Notwithstanding any other provision in this Agreement, nothing in the Generation Interconnection Agreement, nor any other agreement between Seller on the one hand and Transmission Provider or Interconnection Provider on the other hand, nor any alleged

event of default thereunder, shall alter or modify the Parties' rights, duties, and obligation hereunder. This Agreement shall not be construed to create any rights between Seller and the Interconnection Provider or between Seller and the Transmission Provider.

(c) Seller expressly recognizes that, for purposes hereof, the Interconnection Provider and Transmission Provider each shall be deemed to be a separate entity and separate contracting party from PacifiCorp whether or not the Generation Interconnection Agreement is entered into with Interconnection Provider or an Affiliate thereof. Seller acknowledges that PacifiCorp, acting in its merchant capacity function as purchaser hereunder, has no responsibility for or control over Interconnection Provider or Transmission Provider, and is not liable for any breach of agreement or duty by Interconnection Provider or Transmission Provider.

## **SECTION 2 TERM; FACILITY DEVELOPMENT**

2.1 Term; Inter-jurisdictional Cost Allocation. This Agreement shall become effective when it is executed and delivered by both Parties and has been approved by the Commission (the "Effective Date"), and, unless earlier terminated as provided herein, shall remain in effect until the 20th anniversary of the Commercial Operation Date (the "Term"). In the event that the Commission order approving this Agreement requires any change in this Agreement or imposes any requirement or condition not anticipated by the Parties that may reasonably be expected to make either Party's performance under this Agreement commercially impracticable, the Parties may negotiate an amendment to this Agreement in an attempt to restore the Parties to the extent possible, to the commercial position prior to such order. If the Parties are unable to enter into such an amendment within thirty (30) days of the entry of the Commission's order, the Party adversely impacted by such change or condition may terminate this Agreement by providing the other Party notice within thirty (30) days of the entry of the Commission's order.

2.2 Adverse Order. For purposes of inter-jurisdictional cost allocation, this Agreement constitutes a "New QF Contract" under the PacifiCorp Inter-Jurisdictional Cost Allocation Revised Protocol ("Revised Protocol") and, as such, the costs of those QF provisions are allocated as a system resource unless any portion of those costs exceed the cost PacifiCorp would have otherwise incurred acquiring comparable resources. In that event, the Revised Protocol assigns those excess costs on a situs basis to the State of Utah. The rates, terms and conditions in this Agreement are in accordance with the rates, terms and conditions approved by the Commission for purchases from qualifying facilities. In addition, for the purposes of inter-jurisdictional cost allocation, PacifiCorp represents that the costs of this Agreement do not exceed the costs PacifiCorp would have otherwise incurred acquiring resources in the market that are defined as "Comparable Resources" in Appendix A to the Revised Protocol.

2.3 Milestones. Time is of the essence in the performance hereof, and Seller's completion of the Facility and delivery of Net Output by the Scheduled Commercial Operation Date is critically important. Therefore, Seller shall achieve the following milestones at the times indicated:



(a) On or before [REDACTED] Seller shall provide PacifiCorp with a fully executed Generation Interconnection Agreement or a letter (or other form of confirmation acceptable to PacifiCorp) from the Transmission Provider stating the Scheduled Commercial Operation Date is achievable under the standard timelines of the Transmission Provider for the Seller to complete all Interconnection Facilities and to be fully interconnected to the System. If Seller provides a letter (or other form of confirmation acceptable to PacifiCorp) from the Transmission Provider, Seller shall provide a fully executed and effective Generation Interconnection Agreement to PacifiCorp at least ninety (90) days prior to the Scheduled Commercial Operation Date. Seller acknowledges that if it relies upon a letter from the Transmission Provider as described above, PacifiCorp is under no obligation to modify the Scheduled Commercial Operation Date if Transmission Provider, for any reason, fails to complete the Interconnection Facilities for the Facility or otherwise fails to complete the interconnection for the Facility by the date indicated in the letter;

(b) Project Development Security, the amount of which is described in Section 8.1, shall be posted as follows:

(i) On or before the 30th day following the Effective Date, Seller shall post twenty-five percent (25%) of the Project Development Security; and

(ii) On or before the date that is twelve (12) months prior to the Scheduled Commercial Operation Date, Seller shall post the remaining seventy-five percent (75%) of the Project Development Security;

(c) By the Commercial Operation Date, Seller shall provide Default Security required under Section 8.2;

(d) By the Commercial Operation Date, Seller shall provide the Levelized Security required under Section 8.3;

(e) Seller shall provide PacifiCorp with documentation showing that Seller has obtained retail electric service for the Facility prior to the Commercial Operation Date;

(f) Seller shall cause the Facility to achieve Commercial Operation on or before the Guaranteed Commercial Operation Date; and

(g) If Commercial Operation of the Facility is achieved based on less than 100 percent of the Expected Nameplate Capacity Rating, then Seller shall cause the Facility to achieve Final Completion on or before the 90th day after the Commercial Operation Date; provided, however, that the date for achieving each of the foregoing milestones shall be extended on a day for day basis for any delay due solely to (i) PacifiCorp's delay in taking, or failure to take, any action required of it hereunder in breach of this Agreement, or (ii) an event of Force Majeure.

#### 2.4 Project Construction and Delay Damages.

(a) On or before the later of: (i) the Facility Financing Date or (ii) excavation of the first foundation for the photovoltaic panels, Seller shall provide to PacifiCorp a

certificate from a Licensed Professional Engineer confirming that the Required Facility Documents including, but not limited to the material permits, consents and agreements necessary to operate and maintain the Facility have been obtained by Seller.

(b) If Commercial Operation is not achieved on or before the Scheduled Commercial Operation Date, Seller shall pay to PacifiCorp Delay Damages from and after the Scheduled Commercial Operation Date up to, but not including, the date that the Facility achieves Commercial Operation.

(c) If the Facility does not achieve Commercial Operation by the Guaranteed Commercial Operation Date, PacifiCorp may terminate this Agreement pursuant to Section 11 (it being acknowledged and agreed that, in the event PacifiCorp terminates this Agreement pursuant to this Section 2.4(c), Delay Damages shall cease to accrue on the earlier of (i) the date of termination or (ii) one hundred twenty (120) days after the Guaranteed Commercial Operation Date if PacifiCorp has not terminated. Nothing herein shall preclude PacifiCorp from terminating the Agreement one hundred twenty (120) or more days after the Guaranteed Commercial Operation Date.).

(d) After the date of Final Completion, any partially completed Solar Array shall not be part of the Facility, and Seller shall not undertake to add those Solar Array or output from such Solar Array to the Facility without the prior written consent of PacifiCorp. Any output of such Solar Array or Capacity Rights associated with such output shall be treated as Net Output above the Maximum Delivery Rate and is subject to Section 6.8.

2.5 Damages Calculation. Each Party agrees and acknowledges that (a) the damages that PacifiCorp would incur due to Seller's delay in achieving Commercial Operation or Final Completion or failure to reach Final Completion based on 100 percent of the Expected Nameplate Capacity Rating would be difficult or impossible to predict with certainty, and (b) it is impractical and difficult to assess actual damages in the circumstances stated, and therefore the Delay Damages as agreed to by the Parties and set forth herein are a fair and reasonable calculation of such damages. The Parties agree that Delay Damages shall be PacifiCorp's exclusive remedy for a delay in achieving Commercial Operation or failure to reach Final Completion based on 100 percent of the Expected Nameplate Capacity Rating and believe that Delay Damages fairly represent actual damages. Subject to the foregoing sentence, this Section 2.5 shall not limit the amount of damages payable to PacifiCorp if this Agreement is terminated as a result of Seller's failure to achieve Commercial Operation by the Guaranteed Commercial Operation Date. Any such termination damages shall be determined in accordance with Section 11.5. For illustrative purposes only, Exhibit C sets forth an example calculation of Delay Damages.

2.6 Damages Invoicing. By the 10th day following the end of the calendar month in which Delay Damages begin to accrue and continuing on the 10th day of each calendar month during the period in which Delay Damages accrue (and the following months, if applicable), PacifiCorp shall deliver to Seller an invoice showing PacifiCorp's computation of such damages and any amount due PacifiCorp in respect thereof for the preceding calendar month. No later than ten (10) days after receiving such an invoice and subject to Sections 10.3 and 10.4, Seller shall pay to PacifiCorp, by wire transfer of immediately available funds to an account specified

in writing by PacifiCorp or by any other means agreed to by the Parties in writing from time to time, the amount set forth as due in such invoice.

2.7 PacifiCorp's Right to Monitor. During the Term, Seller shall permit PacifiCorp and its advisors and consultants to:

(a) Review and discuss with Seller and its advisors and consultants monthly status reports on the progress of the acquisition, design, financing, engineering, construction and installation of the Facility. Between the Effective Date and thirty (30) days following the date of Final Completion, Seller shall, on or before the 10th day of each calendar month, provide PacifiCorp with a brief monthly status report for the preceding month.

(b) Request and receive periodic updates from Seller regarding the status of the acquisition, land leasing, design, financing, engineering, construction and installation of the Facility and the performance of the contractors constructing the Facility.

(c) Request and receive monthly updates from Seller concerning (i) the progress of Seller's negotiation and execution of contracts for the acquisition, design, financing, engineering, construction and installation of the Facility, Premises, major equipment, and warranties, and (ii) the contractors' performance and achievement of contract deliverables and all performance and other tests required to achieve Commercial Operation or contemplated by the warranty agreements between Seller and a manufacturer of the Facility's Solar Panels and Inverters and any other material items of Facility equipment that require testing for warranty agreements to be effective. Seller shall provide PacifiCorp with at least two (2) Business Days prior notice of each such test, with the understanding that if the performance of such test is dependent on the presence of sufficient solar exposure or other variables beyond the control of Seller, the date of such test may be postponed if, on the date specified in the related notice, there is insufficient solar exposure or other circumstances beyond the control of Seller that prevent the performance of such test on the scheduled date. Seller does not herein grant PacifiCorp the right to review, comment on or approve the terms or conditions of any contract or negotiation between Seller and a third party, the terms and conditions of each such contract or negotiation being confidential and to be determined by Seller in its sole discretion. Conversely, nothing in this Agreement shall be construed to require PacifiCorp to review, comment on, or approve any contract between Seller and a third party.

(d) Witness initial performance tests and other tests and review the results thereof; with Seller to make best efforts to provide PacifiCorp five (5) Business Days' advance notice of each such major test.

(e) Perform such examinations, inspections, and quality surveillance as, in PacifiCorp's reasonable judgment, are appropriate and advisable to determine that the Facility has been properly commissioned and Commercial Operation and Final Completion have been achieved.

With respect to PacifiCorp's right to monitor under this Section 2.7, (i) PacifiCorp is under no obligation to exercise any of these monitoring rights, (ii) such monitoring shall occur subject to reasonable rules developed by Seller regarding Facility construction, access, health, safety, and

environmental requirements, and (iii) PacifiCorp shall have no liability to Seller for failing to advise it of any condition, damages, circumstances, infraction, fact, act, omission or disclosure discovered or not discovered by PacifiCorp with respect to the Facility or any contractor. Any review or monitoring of the Facility conducted by PacifiCorp hereunder shall be performed in a manner that does not impede, hinder, postpone, or delay Seller or its contractors in their performance of the engineering, construction, design or testing of the Facility. PacifiCorp shall maintain one or more designated representatives for purposes of the monitoring activities contemplated in this Section 2.7, which representatives shall have authority to act for PacifiCorp in all technical matters under this Section 2.7 as authorized by PacifiCorp but not to amend or modify any provision hereof. PacifiCorp's initial representatives and their contact information are listed in Exhibit 2.7. PacifiCorp may, by written notice to Seller, change its representatives or their contact information.

2.8 Tax Credits. Seller shall bear all risks, financial and otherwise throughout the Term, associated with Seller's or the Facility's eligibility to receive ITCs or other Tax Credits, or to qualify for accelerated depreciation for Seller's accounting, reporting or tax purposes. The obligations of the Parties hereunder, including those obligations set forth herein regarding the purchase and price for and Seller's obligation to deliver Net Output, shall be effective regardless of whether the sale of Output or Net Output from the Facility is eligible for, or receives, ITCs, or other Tax Credits during the Term.

### **SECTION 3 REPRESENTATIONS AND WARRANTIES**

3.1 Mutual Representations and Warranties. Each Party represents, covenants, and warrants to the other that:

3.1.1 Organization. It is duly organized and validly existing under the laws of the State of its organization.

3.1.2 Authority. It has the requisite power and authority to enter hereinto and to perform according to the terms hereof.

3.1.3 Corporate Actions. It has taken all corporate actions required to be taken by it to authorize the execution, delivery and performance hereof and the consummation of the transactions contemplated hereby.

3.1.4 No Contravention. The execution and delivery hereof does not contravene any provision of, or constitute a default under, any indenture, mortgage, security instrument or undertaking, or other material agreement to which it is a party or by which it is bound, or any valid order of any court, or any regulatory agency or other Governmental Authority having authority to which it is subject.

3.1.5 Valid and Enforceable Agreement. This Agreement is a valid and legally binding obligation of it, enforceable against it in accordance with its terms, except as the enforceability hereof may be limited by general principles of equity or bankruptcy, insolvency, bank moratorium or similar laws affecting creditors' rights generally and laws restricting the availability of equitable remedies.

3.1.6 Litigation. No litigation, arbitration, investigation or other proceeding is pending or, to the best of either Party's knowledge, threatened in writing against either Party or its members, with respect hereto and the transactions contemplated hereunder. No other investigation or proceeding is pending or threatened in writing against a Party, its members, or any Affiliate, the effect of which would materially and adversely affect the Party's performance of its obligations hereunder.

3.2 Seller's Further Representations and Warranties. Seller further represents, covenants, and warrants to PacifiCorp that:

3.2.1 Authority. Seller (a) has (or will have prior to the Commercial Operation Date) all required regulatory authority to make wholesale sales from the Facility; (b) has the power and authority to own and operate the Facility and be present upon the Premises for the Term; and (c) is duly qualified and in good standing under the laws of each jurisdiction where its ownership, lease or operation of property or the conduct of its business requires such qualification.

3.2.2 No Contravention. The execution, delivery, performance and observance by Seller of its obligations hereunder do not and will not:

(a) contravene, conflict with or violate any provision of any material Requirements of Law presently in effect having applicability to either Seller or any of Seller's members;

(b) require the consent or approval of or material filing or registration with any Governmental Authority or other person other than such consents and approvals which are (i) set forth in Exhibit 3.2.3 or (ii) required in connection with the construction or operation of the Facility and expected to be obtained in due course;

(c) result in a breach of or constitute a default under any provision of any security issued by any of Seller's members or managers, the effect of which would materially and adversely affect Seller's performance of, or ability to perform, its obligations hereunder, or any material agreement, instrument or undertaking to which either Seller's members or any Affiliates of Seller's members is a party or by which the property of any of Seller's members or any Affiliates of Seller's members is bound, the effect of which would materially and adversely affect Seller's performance of, or ability to perform, its obligations hereunder.

3.2.3 Required Facility Documents. All Required Facility Documents are listed on Exhibit 3.2.3. Pursuant to the Required Facility Documents, Seller holds as of the Effective Date, or will hold by the Commercial Operation Date (or such other later date as may be specified under Requirements of Law), and will maintain for the Term all Required Facility Documents (including, but not limited to, all material authorizations, rights and entitlements) necessary to construct, own and operate the Facility and to deliver Net Output to PacifiCorp in accordance with this Agreement. The anticipated use of the Facility complies with all applicable restrictive covenants affecting the Premises. Following the Commercial Operation Date, Seller

shall notify PacifiCorp of any additional material consent or approval that is required for the operation and maintenance of the Facility promptly after Seller makes any such determination.

3.2.4 Delivery of Energy. On or before the Commercial Operation Date, Seller shall hold rights sufficient to enable Seller to deliver Net Output at the Nameplate Capacity Rating from the Facility to the Point of Delivery pursuant to this Agreement throughout the Term.

3.2.5 Control of Premises. Seller has all legal rights necessary for the Seller to enter upon and occupy the Premises for the purpose of constructing, operating and maintaining the Facility for the Term. All leases of real property required for the operation of the Facility or the performance of any obligations of Seller hereunder are set forth and accurately described in Exhibit 3.2.6. Seller shall maintain all leases or other land grants necessary for the construction, operation and maintenance of the Facility as valid for the Term. Upon request by PacifiCorp, Seller shall provide copies of the memoranda of lease recorded in connection with the development of the Facility to PacifiCorp.

3.2.6 Undertaking of Agreement; Professionals and Experts. Seller has engaged those professional or other experts it believes necessary to understand its rights and obligations pursuant to this Agreement. All professionals or experts including, but not limited to, engineers, attorneys or accountants, that Seller may have consulted or relied on in undertaking the transactions contemplated by this Agreement have been solely those of Seller.

3.2.7 Verification. All information relating to the Facility, its operation and output provided to PacifiCorp and contained in this Agreement has been verified by Seller and is true and accurate.

3.3 No Other Representations or Warranties. Each Party acknowledges that it has entered hereinto in reliance upon only the representations and warranties set forth in this Agreement, and that no other representations or warranties have been made by the other Party with respect to the subject matter hereof.

3.4 Continuing Nature of Representations and Warranties; Notice. The representations and warranties set forth in this Section are made as of the Effective Date and deemed repeated as of the Commercial Operation Date. If at any time during the Term, any Party obtains actual knowledge of any event or information that would have caused any of the representations and warranties in Section 3 to be materially untrue or misleading at the time given, such Party shall provide the other Party with written notice of the event or information, the representations and warranties affected, and the action, if any, which such Party intends to take to make the representations and warranties true and correct. If at any time the Seller obtains actual knowledge that the representations and warranties in Sections 3.2.1, 3.2.2(a), 3.2.3, 3.2.4 or 3.2.5 are not true, Seller shall provide written notice to PacifiCorp. The notice required pursuant to this Section shall be given as soon as practicable after the occurrence of each such event.

**SECTION 4  
DELIVERIES OF NET OUTPUT**

4.1 Purchase and Sale. Except as otherwise expressly provided herein, commencing on the Commercial Operation Date and continuing through the Term, Seller shall sell and make available to PacifiCorp, and PacifiCorp shall purchase and receive the entire Net Output from the Facility at the Point of Delivery. PacifiCorp shall be under no obligation to make any purchase hereunder other than Net Output, as described above. PacifiCorp shall not be obligated to purchase, receive or pay for Net Output that is not delivered to the Point of Delivery. In addition, during the period between the Effective Date and the Commercial Operation Date, Seller shall sell and make available to PacifiCorp, and PacifiCorp shall purchase and receive, all Net Output from the Facility as Test Energy at the price specified in Section 5.1.1.

4.2 No Sales to Third Parties. During the Term, Seller shall not sell any Net Output, energy, or Capacity Rights from the Facility to any party other than PacifiCorp; provided, however, that this restriction shall not apply during periods when PacifiCorp is in default hereof because it has failed to accept or purchase Net Output as required hereunder.

4.3 Title and Risk of Loss of Net Output. Seller shall deliver Net Output to the Point of Delivery and Capacity Rights free and clear of all liens, claims and encumbrances. Title to and risk of loss of all Net Output shall transfer from Seller to PacifiCorp upon its delivery to PacifiCorp at the Point of Delivery. Seller shall be deemed to be in exclusive control of, and responsible for, any damage or injury caused by, all Output up to and at the Point of Delivery. PacifiCorp shall be deemed to be in exclusive control of, and responsible for, any damages or injury caused by, Net Output after the Point of Delivery.

4.4



4.5 PacifiCorp as Merchant. Seller acknowledges that PacifiCorp, acting in its merchant capacity function as purchaser under this Agreement, has no responsibility for or control over PacifiCorp Transmission or any successor Transmission Provider.

4.6 Title to Green Tags. As a result of the Commission order in Docket No. 12-035-100 dated August 16, 2013, PacifiCorp waives any claim to Seller's ownership of Green Tags under this Agreement.

4.6.1 Purchase and Sale of Capacity Rights. For and in consideration of PacifiCorp's agreement to purchase from Seller the Facility's Net Output on the terms and conditions set forth herein, Seller transfers to PacifiCorp, and PacifiCorp accepts from Seller, any right, title, and interest that Seller may have in and to Capacity Rights, if any, existing during the Term.

4.6.2 Representation Regarding Ownership of Capacity Rights. Seller represents that it has not sold, and covenants that during the Term it will not sell or attempt to sell to any other person or entity the Capacity Rights, if any. During the Term, Seller shall not report to any person or entity that the Capacity Rights, if any, belong to anyone other than PacifiCorp. PacifiCorp may at its own risk and expense report to any person or entity that Capacity Rights exclusively belong to it.

4.6.3 Further Assurances. At PacifiCorp's request, the Parties shall execute such documents and instruments as may be reasonably required to effect recognition and transfer of the Net Output or Capacity Rights, if any, to PacifiCorp.

## **SECTION 5 CONTRACT PRICE; COSTS**

5.1 Contract Price; Includes Capacity Rights. PacifiCorp shall pay Seller the prices stated below for all deliveries of Net Output and Capacity Rights, up to the Maximum Delivery Rate. The Contract Price provided for in Section 5.1.2 and the price for Test Energy provided for in Section 5.1.1 include the consideration to be paid by PacifiCorp to Seller for all Capacity Rights and Test Energy, respectively, and Seller shall not be entitled to any compensation over and above the Contract Price or the Test Energy price, as the case may be, for the Capacity Rights associated therewith.

5.1.1 Test Energy and Net Output Before Later of Commercial Operation Date and Scheduled Commercial Operation Date. Between the Effective Date and the later to occur of the (i) Commercial Operation Date or (ii) the Scheduled Commercial Operation Date, Seller shall sell and deliver to PacifiCorp all Test Energy and Net Output. PacifiCorp shall pay Seller for such Test Energy and Net Output delivered at the Point of Delivery,

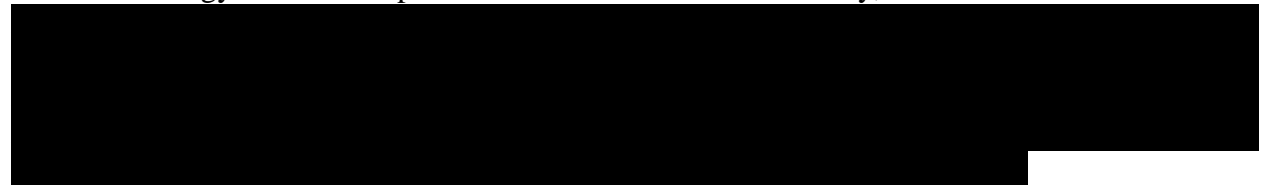



5.1.2 Net Output After The Later of Commercial Operation Date and Scheduled Commercial Operation Date. For the period beginning on the later of (i) the Commercial Operation Date or (ii) the Scheduled Commercial Operation Date and thereafter during the Term, PacifiCorp shall pay to Seller the Contract Price per MWh of Net Output delivered to the Point of Delivery, as specified in Exhibit 5.1.

5.2 Costs and Charges. Seller shall be responsible for paying or satisfying when due all costs or charges imposed in connection with the scheduling and delivery of Net Output up to and at the Point of Delivery, including transmission costs, Transmission Service, and transmission line losses, and any operation and maintenance charges imposed by Interconnection Provider and Transmission Provider for the Interconnection Facilities. PacifiCorp shall be responsible for all costs or charges, if any, imposed in connection with the delivery of Net Output at and from the Point of Delivery, including transmission costs and transmission line losses and imbalance charges or penalties. Without limiting the generality of the foregoing, Seller, in accordance with the Generation Interconnection Agreement, shall bear all costs associated with the modifications to Interconnection Facilities or the System (including system upgrades) caused by or related to (a) the interconnection of the Facility with the System and (b) any increase in generating capacity of the Facility.

5.3 Station Service. Seller shall be responsible for arranging and obtaining, at its sole risk and expense, any station service required by the Facility that is not provided by the Facility itself.

5.4 Taxes. Seller shall pay or cause to be paid when due, or reimburse PacifiCorp for, all existing and any new sales, use, excise, severance, ad valorem, and any other similar taxes, imposed or levied by any Governmental Authority on the Net Output, Capacity Rights or Green Tags (if owned by PacifiCorp as provided in Section 4.6) up to and including, but not beyond, the Point of Delivery, regardless of whether such taxes are imposed on PacifiCorp or Seller under Requirements of Law. PacifiCorp shall pay or cause to be paid when due all such taxes imposed or levied by any Governmental Authority on the Net Output, Capacity Rights or Green Tags (if owned by PacifiCorp as provided in Section 4.6) beyond the Point of Delivery, regardless of whether such taxes are imposed on PacifiCorp or Seller under Requirements of Law. The Contract Price shall not be adjusted on the basis of any action of any Governmental Authority with respect to changes to or revocations of sales and use tax benefits, rebates, exception or give back. In the event any taxes are imposed on a Party for which the other Party is responsible hereunder, the Party on which the taxes are imposed shall promptly provide the other Party notice thereof and such other information as such Party may reasonably request with respect to any such taxes.

5.5 Costs of Ownership and Operation. Without limiting the generality of any other provision hereof and subject to Section 5.4, Seller shall be solely responsible for paying when due (a) all costs of owning and operating the Facility in compliance with existing and future Requirements of Law and the terms and conditions hereof, and (b) all taxes and charges (however characterized) now existing or hereinafter imposed on or with respect to the Facility, its operation, or on or with respect to emissions or other environmental impacts of the Facility, including any such tax or charge (however characterized) to the extent payable by a generator of such energy or environmental attributes.

5.6 Rates Not Subject to Review. The rates for service specified herein shall remain in effect until expiration of the Term, and shall not be subject to change for any reason, including regulatory review, absent agreement of the parties. Neither Party shall petition FERC pursuant to the provisions of Sections 205 or 206 of the Federal Power Act (16 U.S.C. § 792 et seq.) to amend such prices or terms, or support a petition by any other person seeking to amend such prices or terms, absent an agreement in writing of the other Party. Further, absent an agreement in writing by both Parties, the standard of review for changes hereto proposed by a Party, a non-party or FERC acting sua sponte shall be the “public interest” application of the “just and reasonable” standard of review set forth in United Gas Pipe Line Co. v. Mobile Gas Service Corp., 350 U.S. 332 (1956) and Federal Power Commission v. Sierra Pacific Power Co., 350 U.S. 348 (1956) and clarified by Morgan Stanley Capital Group, Inc. v. Public Util. Dist. No. 1 of Snohomish, 554 U.S. 527, 128 S. Ct. 2733 (2008).

## **SECTION 6 OPERATION AND CONTROL**

6.1 As-Built Supplement. Within ninety (90) days of completion of construction of the Facility, Seller shall provide PacifiCorp the As-built Supplement. The As-built Supplement shall be deemed effective and shall be added to Exhibit 6.1 when it has been reviewed and approved by PacifiCorp, which approval shall not be unreasonably withheld or delayed. If the proposed As-built Supplement does not accurately describe the Facility as actually built or is otherwise defective as to form in any material respect, PacifiCorp may within fifteen (15) days after receiving the proposed As-built Supplement give Seller a notice describing what PacifiCorp wishes to correct. If PacifiCorp does not give Seller such a notice within the 15-day period, the As-built Supplement shall be deemed approved. If PacifiCorp provides a timely notice requiring corrections, Seller shall in good faith cooperate with PacifiCorp to revise the As-built Supplement to address PacifiCorp’s concerns. Notwithstanding the foregoing, PacifiCorp shall have no right to require Seller to relocate, modify or otherwise change in any respect any aspect of the Facility as actually built.

### 6.2 Standard of Facility Operation.

6.2.1 General. At Seller’s sole cost and expense, Seller shall build, operate, maintain and repair the Facility and the Interconnection Facilities in accordance with (a) the applicable and mandatory standards, criteria and formal guidelines of FERC, NERC, any RTO, and any other Electric System Authority and any successors to the functions thereof; (b) the Permits and Required Facility Documents; (c) the Generation Interconnection Agreement; (d) all Requirements of Law; (e) the requirements hereof; and (f) Prudent Electrical Practices. Seller acknowledges that it shall have no claims hereunder against PacifiCorp with respect to any requirements imposed by or damages caused by (or allegedly caused by) the Transmission Provider. Seller will have no claims against PacifiCorp under this Agreement with respect to the provision of station service.

6.2.2 Qualified Operator. From and after the Commercial Operation Date, Seller or an Affiliate of Seller shall itself operate the Facility or cause the Facility to be operated by an entity approved by PacifiCorp, which approval shall not be unreasonably withheld or

delayed. Seller shall provide PacifiCorp thirty (30) days prior written notice of any change in operator.

6.2.3 Fines and Penalties.

(a) Without limiting a Party's rights under Section 6.2.3(b), each Party shall pay all fines and penalties incurred by such Party on account of noncompliance by such Party with Requirements of Law in respect to this Agreement, except where such fines and penalties are being contested in good faith through appropriate proceedings.

(b) If fines, penalties, or legal costs are assessed against or incurred by either Party (the "Indemnified Party") on account of any action by any Governmental Authority due to noncompliance by the other Party (the "Indemnifying Party") with any Requirements of Law or the provisions hereof, or if the performance of the Indemnifying Party is delayed or stopped by order of any Governmental Authority due to the Indemnifying Party's noncompliance with any Requirements of Law, the Indemnifying Party shall indemnify and hold harmless the Indemnified Party against any and all losses, liabilities, damages, and claims suffered or incurred by the Indemnified Party as a result thereof. Without limiting the generality of the foregoing, the Indemnifying Party shall reimburse the Indemnified Party for all fees, damages, or penalties imposed on the Indemnified Party by any Governmental Authority, other person or to other utilities for violations to the extent caused by a default by the Indemnifying Party or a failure of performance by the Indemnifying Party hereunder.

6.3 Interconnection. Seller shall be responsible for the costs and expenses associated with interconnection of the Facility at its Nameplate Capacity Rating at the Point of Delivery. Seller shall have no claims hereunder against PacifiCorp, acting in its merchant function capacity, with respect to any requirements imposed by or damages caused by (or allegedly caused by) acts or omissions of the Transmission Provider or Interconnection Provider, in connection with the Generation Interconnection Agreement or otherwise.

6.4 Coordination with System. Seller shall be responsible for the coordination and synchronization of the Facility and the Interconnection Facilities with the System.

6.5 Outages.

6.5.1 Planned Outages. Except as otherwise provided herein, Seller shall not schedule a Planned Outage during day light hours (sun-up to sunset) during any portion of the months of November, December, January, February, June, July, and August, except to the extent a Planned Outage is reasonably required to enable a vendor to satisfy a guarantee requirement. Seller shall provide PacifiCorp with an annual forecast of Planned Outages for each Contract Year at least one month, but no more than three (3) months, before the first day of that Contract Year, and shall promptly update such schedule, or otherwise change it only, to the extent that Seller is reasonably required to change it in order to comply with Prudent Electrical Practices. Seller shall not schedule any maintenance of Interconnection Facilities during such months, without the prior written approval of PacifiCorp, which approval shall not be unreasonably withheld or delayed.

6.5.2 Maintenance Outages. If Seller reasonably determines that it is necessary to schedule a Maintenance Outage, Seller shall notify PacifiCorp of the proposed Maintenance Outage as soon as practicable but in any event at least five (5) days before the outage begins (or such shorter period consistent with Prudent Electrical Practices). Upon such notice, the Parties shall plan the Maintenance Outage to mutually accommodate the reasonable requirements of Seller and the service obligations of PacifiCorp; provided, however, that Seller shall take all reasonable measures consistent with Prudent Electrical Practices to not schedule any Maintenance Outage during the day light hours of the following periods: November, December, January, February, June 15 through June 30, July, August, and September 1 through September 15. Notice of a proposed Maintenance Outage shall include the expected start date and time of the outage, the amount of generation capacity of the Facility that will not be available, and the expected completion date and time of the outage. Seller shall give PacifiCorp notice of the Maintenance Outage as soon as reasonably practicable after Seller determines that the Maintenance Outage is necessary. PacifiCorp shall promptly respond to such notice and may request reasonable modifications in the schedule for the outage. Seller shall use all reasonable efforts to comply with any request to modify the schedule for a Maintenance Outage provided that such change has no substantial impact on Seller. Seller shall notify PacifiCorp of any subsequent changes in generation capacity available to PacifiCorp as a result of such Maintenance Outage or any changes in the Maintenance Outage completion date and time. As soon as practicable, any notifications given orally shall be confirmed in writing. Seller shall take all reasonable measures consistent with Prudent Electrical Practices to minimize the frequency and duration of Maintenance Outages. Notwithstanding anything in this Section 6.5.2 to the contrary, Seller may schedule a Maintenance Outage at any time and without the requirement to notify PacifiCorp in advance during conditions of low solar exposure.

6.5.3 Forced Outages. Seller shall promptly provide to PacifiCorp an oral report, via telephone to a number specified by PacifiCorp (or other method approved by PacifiCorp), of any Forced Outage resulting in more than 10 percent of the Nameplate Capacity Rating of the Facility being unavailable. This report shall include the amount of the generation capacity of the Facility that will not be available because of the Forced Outage and the expected return date of such generation capacity. Seller shall promptly update the report as necessary to advise PacifiCorp of changed circumstances. As soon as practicable, the oral report shall be confirmed in writing by notice to PacifiCorp. Seller shall take all reasonable measures consistent with Prudent Electrical Practices to avoid Forced Outages and to minimize their duration.

6.5.4 Notice of Deratings and Outages. Without limiting the foregoing, Seller will inform PacifiCorp, via telephone to a number specified by PacifiCorp (or other method approved by PacifiCorp), of any major limitations, restrictions, deratings or outages known to Seller affecting the Facility for the following day (except for curtailments pursuant to Section 4.4(b)) and will promptly update Seller's notice to the extent of any material changes in this information, with "major" defined as affecting more than 5 percent of the Nameplate Capacity Rating of the Facility.

6.5.5 Effect of Outages on Estimated Output. Seller represents and warrants that the estimated monthly net output set forth on Exhibit A takes into account the Planned Outages, Maintenance Outages, and Forced Outages that Seller reasonably expects to encounter in the ordinary course of operating the Facility.

6.6 Scheduling.

6.6.1 Cooperation and Standards. With respect to any and all scheduling requirements hereunder, (a) Seller shall cooperate with PacifiCorp with respect to scheduling Net Output, and (b) each Party shall designate authorized representatives to communicate with regard to scheduling and related matters arising hereunder. Each Party shall comply with the applicable variable resource standards and criteria of any applicable Electric System Authority.

6.6.2 Schedule Coordination. If, as a result hereof, PacifiCorp is deemed by an RTO to be financially responsible for Seller's performance under the Generation Interconnection Agreement, due to Seller's lack of standing as a "scheduling coordinator" or other RTO recognized designation, qualification or otherwise, then Seller shall acquire such RTO recognized standing (or shall contract with a third party who has such RTO recognized standing) such that PacifiCorp is no longer responsible for Seller's performance under the Generation Interconnection Agreement or RTO requirement.

6.7 Forecasting.

6.7.1 Long-Range Forecasts. For PacifiCorp's planning purposes, Seller shall, by December 1 of each year during the Term (except for the last year of the Term), provide an annual update to the expected long-term monthly/diurnal mean net energy estimates (12 X 24 profile).

6.7.2 Day-Ahead Forecasts and Updates. By such time as mutually agreed to by the Parties on the Business Day immediately preceding the day on which Net Output from the Facility is to be delivered, Seller shall provide PacifiCorp with an hourly forecast of deliveries for each hour of the next day; provided, however, that a forecast provided on a day before any non-Business Day shall include forecasts for each day to and including the next Business Day. The Parties shall cooperate to implement and use automatic forecast updates. Seller shall communicate forecasts under this Section 6.7.2 in an efficient manner, including electronic mail or other such media as determined by PacifiCorp (which, at PacifiCorp's discretion, may be in lieu of or in addition to notice to PacifiCorp). PacifiCorp may, with the advance written consent of Seller and at Seller's expense, add forecasting services for Seller's Facility to PacifiCorp's existing contract with a qualified solar-energy-production forecasting vendor, which contract and vendor may change during the term of this Agreement. The Parties agree that the forecasting obligations of Seller under this Section 6.7 may be met by a solar forecast service provider engaged by PacifiCorp. Upon request by PacifiCorp, Seller shall provide a 24-hour telephone number that PacifiCorp may contact to determine the then-current status of the Facility. PacifiCorp may at its cost and without the prior consent of Seller add the Facility to PacifiCorp's existing qualified solar-energy-production forecasting vendor contract.

6.7.3 Basis of Forecasts. The forecasts called for by this Agreement shall be non-binding, good faith estimates only, and PacifiCorp expressly releases and holds harmless Seller from any liability for forecasting errors. Seller shall prepare such forecasts and updates by utilizing a solar exposure model or service that is (a) commercially available or proprietary to Seller or an Affiliate of Seller, and (b) comparable in accuracy to models or services commonly used in the solar energy industry, so long as such model or service is available at a commercially

reasonable cost and is satisfactory to PacifiCorp in the exercise of its reasonable discretion. On or prior to May 1 during each calendar year in the Term, Seller shall determine in good faith which such model or service to utilize after consultation with PacifiCorp.

6.8 Increase in Nameplate Capacity Rating; New Project Expansion or Development. Without limiting any restrictions herein on Nameplate Capacity Rating, if Seller elects to increase, at its own expense, the ability of the Facility to deliver Net Output in quantities in excess of the Maximum Delivery Rate through any means, including replacement or modification of Facility equipment or related infrastructure, PacifiCorp shall not be required to purchase any Net Output above the Maximum Delivery Rate. If Seller or any Affiliate elects to build an expansion or additional solar project within one mile of the Facility (measured from the nearest generation equipment at both locations), Seller shall have no rights pursuant to this Agreement to require PacifiCorp to purchase (and PacifiCorp shall have no obligation to purchase pursuant to this Agreement) the output of any such expansion or additional facility. Any such expansion or additional facility may not materially and adversely impact the ability of either Party to fulfill its obligations pursuant hereto.

6.9 Electronic Communications.

6.9.1 Telemetry. Seller shall during the Term provide telemetry equipment and facilities capable of transmitting the following information concerning the Facility pursuant to the Generation Interconnection Agreement and to PacifiCorp on a real-time basis, and will operate such equipment when requested by PacifiCorp to indicate:

- (a) instantaneous MW output at the Point of Delivery;
- (b) Net Output; and
- (c) the Facility's total instantaneous generation capacity.

Seller shall also transmit or cause to be transmitted to or make accessible to PacifiCorp any other data from the Facility that Seller receives on a real time basis, including meteorological data, solar exposure data and Net Output data. Such real time data shall be provided to or be made accessible to PacifiCorp on the same basis on which Seller receives the data (e.g., if Seller receives the data in four second intervals, PacifiCorp shall also receive the data in four second intervals).

6.9.2 Transmission Provider Consent. Seller shall execute a consent, in the form required by Transmission Provider, to provide that PacifiCorp can read the meter and receive any and all data from the Transmission Provider relating to transmission of Output or other matters relating to the Facility without the need for further consent from Seller.

6.9.3 Dedicated Communication Circuit. Seller shall install a dedicated direct communication circuit (which may be by common carrier telephone) between PacifiCorp and the control center in the Facility's control room or such other communication equipment as the Parties may agree.

6.10 Reports and Records.

6.10.1 Quarterly Reports. Commencing on the Commercial Operation Date, within thirty (30) days after the end of each calendar quarter during the Term (each, a “Reporting Quarter”), Seller shall provide to PacifiCorp a report in electronic format, which report shall include (a) summaries of any significant events related to the construction or operation of the Facility for the Reporting Quarter; and (b) any supporting information that PacifiCorp may from time to time reasonably request (including historical solar exposure data for the Facility). PacifiCorp, in its discretion, may waive by providing written notice to Seller, the quarterly reporting requirements required in this Section 6.10.1.

6.10.2 Electronic Fault Log. Seller shall maintain an electronic fault log of operations of the Facility during each hour of the Term commencing on the Commercial Operation Date. Seller shall provide PacifiCorp with a copy of the electronic fault log within thirty (30) days after the end of the calendar month to which the fault log applies.

6.10.3 Other Information to be Provided to PacifiCorp. Seller shall provide to PacifiCorp the following information concerning the Facility:

- (a) Upon the request of PacifiCorp, the manufacturers’ guidelines and recommendations for maintenance of the Facility equipment;
- (b) A report summarizing the results of maintenance performed during each Maintenance Outage, Planned Outage, and any Forced Outage, and upon request of PacifiCorp any of the technical data obtained in connection with such maintenance;
- (c) Before Final Completion, a monthly progress report stating the percentage completion of the Facility and a brief summary of construction activity during the prior month;
- (d) Before Final Completion, a monthly report containing a brief summary of construction activity contemplated for the next calendar month;
- (e) At any time from the Effective Date, one year’s advance notice of the termination or expiration of any material agreement, including Leases, pursuant to which the Facility or any material equipment relating thereto is upon the Premises; provided that the foregoing does not authorize any early termination of any land lease. In the event Seller has less than one year’s advance notice of such termination or expiration, Seller shall provide the notice contemplated by this Section to PacifiCorp within fifteen (15) Business Days of Seller obtaining knowledge of the termination or expiration.

6.10.4 Information to Governmental Authorities. Seller shall, promptly upon written request from PacifiCorp, provide PacifiCorp with data collected by Seller related to the construction, operation or maintenance of the Facility reasonably required by PacifiCorp or an Affiliate thereof for reports to, and information requests from, any Governmental Authority or Electric System Authority. Along with this information, Seller shall provide to PacifiCorp copies of all submittals to Governmental Authorities or Electric System Authorities directed by PacifiCorp and related to the operation of the Facility with a certificate that the contents of the

submittals are true and accurate to the best of Seller's knowledge. Seller shall use best efforts to provide this information to PacifiCorp with sufficient advance notice to enable PacifiCorp to review such information and meet any submission deadlines imposed by the requesting organization or entity. PacifiCorp shall reimburse Seller for all of Seller's reasonable actual costs and expenses in excess of \$10,000 per year (this amount shall escalate at 2.5 percent per Contract Year), if any, incurred in connection with PacifiCorp's requests for information under this Section 6.10.4.

6.10.5 Data Request. Seller shall, promptly upon written request from PacifiCorp, provide PacifiCorp with data collected by Seller related to the construction, operation or maintenance of the Facility reasonably required for information requests from any Governmental Authorities, state or federal agency intervenor or any other party achieving intervenor status in any PacifiCorp rate proceeding or other proceeding before any Governmental Authority. Seller shall use best efforts to provide this information to PacifiCorp sufficiently in advance to enable PacifiCorp to review it and meet any submission deadlines. PacifiCorp shall reimburse Seller for all of Seller's reasonable actual costs and expenses in excess of \$10,000 per year (this amount shall escalate at 2.5 percent per Contract Year), if any, incurred in connection with PacifiCorp's requests for information under this Section 6.10.5.

6.10.6 Documents to Governmental Authorities. After sending or filing any statement, application, and report or any document with any Governmental Authority or Electric System Authority relating to operation and maintenance of the Facility, Seller shall promptly provide to PacifiCorp a copy of the same.

6.10.7 Environmental Information. Seller shall, promptly upon written request from PacifiCorp, provide PacifiCorp with all data reasonably requested by PacifiCorp relating to environmental information under the Required Facility Documents. Seller shall further provide PacifiCorp with information relating to environmental impact mitigation measures it is taking in connection with the Facility's construction or operation that are required by any Governmental Authority. PacifiCorp shall reimburse Seller for all of Seller's reasonable actual costs and expenses in excess of \$10,000 per year (this amount shall escalate at 2.5 percent per Contract Year), if any, incurred in connection with PacifiCorp's requests for the foregoing information under this Section 6.10.7. As soon as it is known to Seller, Seller shall disclose to PacifiCorp, the extent of any material violation of any environmental laws or regulations arising out of the construction or operation of the Facility, or the presence of Environmental Contamination at the Facility or on the Premises, alleged to exist by any Governmental Authority having jurisdiction over the Premises, or the present existence of, or the occurrence during Seller's occupancy of the Premises of, any enforcement, legal, or regulatory action or proceeding relating to such alleged violation or alleged presence of Environmental Contamination presently occurring or having occurred during the period of time that Seller has occupied the Premises.

6.10.8 Operational Reports. Upon PacifiCorp's reasonable advance written request, which request shall not be more than once quarterly, Seller shall provide PacifiCorp operational reports in a form and substance reasonably acceptable to PacifiCorp, and Seller shall, promptly upon reasonable written request from PacifiCorp, provide PacifiCorp with all operational data requested by PacifiCorp with respect to the performance of the Facility and delivery of Net Output or Capacity Rights therefrom.



6.10.9 Notice of Material Adverse Events. Seller shall promptly notify PacifiCorp of receipt of written notice or actual knowledge by Seller or its Affiliates of the occurrence of any event of default under any material agreement to which Seller is a party and of any other development, financial or otherwise, which would have a material adverse effect on Seller, the Facility or Seller's ability to develop, construct, operate, maintain or own the Facility as provided herein.

6.10.10 Notice of Litigation. Following its receipt of written notice or actual knowledge of the commencement of any action, suit, or proceeding before any court or Governmental Authority against Seller or its members with respect to this Agreement or the transactions contemplated hereunder, Seller shall promptly give notice to PacifiCorp of the same. Following its receipt of written notice or actual knowledge of the commencement of any action, suit or proceeding before any court or Governmental Authority against Seller, its members or any Affiliate, the effect of which would materially and adversely affect Seller's performance of its obligations hereunder, Seller shall promptly give notice to PacifiCorp of the same.

6.10.11 Additional Information. Seller shall provide to PacifiCorp such other information respecting the condition or operations of Seller, as such pertains to Seller's performance of its obligations hereunder, or the Facility as PacifiCorp may, from time to time, reasonably request.

6.10.12 Confidential Treatment. The periodic reports and other information provided to PacifiCorp under this Section 6.10 shall be treated as Confidential Business Information if such treatment is requested in writing by Seller at the time the information is provided to PacifiCorp, subject to PacifiCorp's rights to disclose such information pursuant to Sections 6.10.4, 6.10.5, 6.10.7, 9.5, 9.6, 23.2 and 23.3, and pursuant to any applicable Requirements of Law. Seller shall have the right to seek confidential treatment of any such information from the Governmental Authority entitled to receive such information.

6.11 Financial and Accounting Information. If PacifiCorp or one of its Affiliates determines that, under (i) the Accounting Standards Codification (ASC) 810, Consolidation of Variable Interest Entities, and (ii) Requirements of Law that it may hold a variable interest in Seller, but it lacks the information necessary to make a definitive conclusion, Seller hereby agrees to provide, upon PacifiCorp's written request, sufficient financial and ownership information so that PacifiCorp or its Affiliate may confirm whether a variable interest does exist under ASC 810 and Requirements of Law. If PacifiCorp or its Affiliate determines that, under ASC 810, it holds a variable interest in Seller, Seller hereby agrees to provide, upon PacifiCorp's written request, sufficient financial and other information to PacifiCorp or its Affiliate so that PacifiCorp may properly consolidate the entity in which it holds the variable interest or present the disclosures required by ASC 810 and Requirements of Law. PacifiCorp shall reimburse Seller for Seller's reasonable costs and expenses, if any, incurred in connection with PacifiCorp's requests for information under this Section 6.11. The information provided to PacifiCorp under this Section 6.11 shall be treated as Confidential Business Information if at the time the Seller provides such information to PacifiCorp the Seller provides written notice that the information is Confidential Business Information. Seller shall have the right to seek confidential treatment of any such information from any Governmental Authority entitled to receive such information. Information provided pursuant to this Section is subject to PacifiCorp's rights to

disclose such information pursuant to Sections 6.10.4, 6.10.5, 6.10.7, 9.5, 9.6, 23.2 and 23.3, and pursuant to any applicable Requirements of Law.

6.12 Output Guarantee.

6.12.1 Output Guarantee. Seller is obligated to deliver a quantity of Net Output during each Rolling Period which is equal to the Output Guarantee. For purposes of this Agreement, “Output Guarantee” for any Rolling Period means the sum of (i) [REDACTED] of the Expected Output of the Facility for such Rolling Period, less (ii) any quantities of Output that were not delivered to the Point of Delivery (or accepted by PacifiCorp) in such Rolling Period during periods constituting Seller Uncontrollable Minutes (such quantity calculated on the basis of the Net Output capable of being delivered in an hour at an average rate equivalent to the actual Nameplate Capacity Rating). For purposes of this Agreement, “Rolling Period” means any two consecutive Contract Years occurring during the Term.

6.12.2 Liquidated Damages for Output Shortfall.

(a) If the quantity of Net Output delivered by the Facility during any Rolling Period is equal to or greater than the Output Guarantee for such Rolling Period, Seller’s delivery obligation for such Rolling Period shall be deemed satisfied for such Rolling Period.

(b) If the quantity of Net Output delivered by the Facility during any Rolling Period is less than the Output Guarantee for such Rolling Period, the Seller shall determine the resulting shortfall, if any, for the first Contract Year occurring during such Rolling Period (the “Output Shortfall”). The Output Shortfall shall be expressed in MWh and calculated in accordance with the following formula:

Output Shortfall = ([REDACTED] of the Expected Output for the Contract Year).

*less*

Any quantities of Output that were not delivered to the Point of Delivery (or accepted by PacifiCorp) in such Contract Year during periods constituting Seller Uncontrollable Minutes (such quantity calculated on the basis of the Net Output capable of being delivered in an hour at an average rate equivalent to the actual Nameplate Capacity Rating),

*less*

The Net Output for the Contract Year

(c) If the product of the Output Shortfall calculation set forth in Section 6.12.2(b) is a positive number, Seller shall pay PacifiCorp liquidated damages equal to the product of (a) the Output Shortfall for that Contract Year, multiplied by (b) PacifiCorp’s Cost to Cover for that Contract Year. If the product of the Output Shortfall calculation set forth in Section 6.12.2(b) is a negative number, Seller shall not be obligated to pay PacifiCorp liquidated damages for such Contract Year.

(d) Each Party agrees and acknowledges that (i) the damages that PacifiCorp would incur due to the Facility's failure to achieve the Output Guarantee would be difficult or impossible to predict with certainty and (ii) the liquidated damages contemplated by this provision are a fair and reasonable calculation of such damages.

(e) For illustrative purposes only, set forth on Exhibit 6.12.2 is an example calculation of liquidated damages for an Output Shortfall.

6.12.3 Annual Invoicing. On the 30th day following the end of each Rolling Period, Seller shall deliver to PacifiCorp a report (and supporting data) detailing whether Seller achieved the Output Guarantee for the most recently completed Rolling Period. In the case of the Seller failing to achieve the Output Guarantee in the prior Rolling Period, Seller shall also provide a report (and supporting data) to PacifiCorp detailing the Output Shortfall for the first Contract Year occurring during such Rolling Period. Seller shall provide documentation to support all data and calculations used in each report to calculate the percent Expected Output. Thirty (30) days after PacifiCorp has received the report and all support data, if applicable, PacifiCorp shall deliver to Seller an invoice showing PacifiCorp's computation of liquidated damages calculated pursuant to Section 6.12.2. In preparing such invoices, PacifiCorp shall utilize the meter data provided to PacifiCorp for the Contract Year in question, but may also rely on historical averages and such other information as may be available to PacifiCorp at the time of invoice preparation, if the meter data for such Contract Year is then incomplete or otherwise not available. To the extent required, PacifiCorp shall true up any such invoice as promptly as practicable following its receipt of actual results for the relevant Contract Year. Seller shall pay to PacifiCorp, by wire transfer of immediately available funds to an account specified in writing by PacifiCorp or by any other means agreed to by the Parties in writing from time to time, the amount set forth as due in such invoice, and shall within thirty (30) days after receiving the invoice raise any objections regarding any disputed portion of the invoice. All disputes regarding such invoices shall be subject to Section 10.4. Objections not made by Seller within the 30-day period shall be deemed waived.

6.13 Access Rights. Upon reasonable prior notice and subject to the prudent safety requirements of Seller, and Requirements of Law relating to workplace health and safety, Seller shall provide PacifiCorp and its authorized agents, employees and inspectors ("PacifiCorp Representatives") with reasonable access to the Facility: (a) for the purpose of reading or testing metering equipment, (b) as necessary to witness any acceptance tests, (c) to provide tours of the Facility to customers and other guests of PacifiCorp (not more than 12 times per year), (d) for purposes of implementing Sections 2.7 or 10.5, and (e) for other reasonable purposes at the reasonable request of PacifiCorp. PacifiCorp shall release Seller against and from any and all Liabilities resulting from actions or omissions by any of the PacifiCorp Representatives in connection with their access to the Facility, except to the extent that such damages are caused or by the intentional or grossly negligent act or omission of Seller.

6.14 Facility Images. PacifiCorp shall be free to use any and all images from or of the Facility for promotional purposes, which images and any related descriptions are subject to Seller's consent (not to be unreasonably withheld or delayed, and which consent may consider Requirements of Law relating to Premises security, obligations to outside vendors (including any confidentiality obligations), and the corporate policies of Seller's Affiliates). Upon PacifiCorp's

request and at PacifiCorp’s expense, Seller shall install imaging equipment at the Facility as PacifiCorp may request, including video and or web-based imaging equipment subject to the prudent safety requirements of Seller, and Requirements of Law relating to workplace health and safety. PacifiCorp shall retain full discretion on how such images are presented including associating images of the Facility with a PacifiCorp-designated corporate logo.

6.15 Installation of Additional Equipment. Notwithstanding anything to the contrary in Section 6.8, Seller may, in accordance with this Section 6.15, add additional equipment to the Facility, as it deems necessary or appropriate in its reasonable discretion, to reach (but not to exceed) its Expected Output in the first full Contract Year, unless, after such additional equipment is installed, the Maximum Delivery Rate would exceed 80,000 kW or would in any way be contrary to or otherwise violate any provision of the Seller’s Generation Interconnection Agreement for the Facility.

## **SECTION 7 QUALIFYING FACILITY STATUS**

7.1 Seller’s QF Status. Seller covenants that, during the Term and before delivering Net Output to PacifiCorp hereunder, Seller shall cause the Facility to be a QF.

7.2 QF Facility. Seller shall provide PacifiCorp with copies of the appropriate certification (which may include a FERC self-certification) within ten (10) days of filing or receiving the certification. During the Term, Seller shall, to the extent required to prevent Seller from being regulated as a “Public Utility” pursuant to PUHCA or otherwise, maintain its QF status, and shall not seek to change the Contract Price as a result of its status as a QF. At any time during the Term, PacifiCorp may require Seller, at Seller’s sole cost, to provide PacifiCorp with evidence satisfactory to PacifiCorp in its reasonable discretion that the Facility continues to qualify as a QF under all applicable requirements and, if PacifiCorp is not satisfied that the Facility qualifies for such status, a written legal opinion from an attorney who is (a) in good standing before a state bar in the United States, and (b) has no economic relationship, association or nexus with the Seller or the Facility, stating that the Facility is a QF and providing sufficient proof (including copies of all documents and data as PacifiCorp may request) demonstrating that Seller has maintained and will continue to maintain the Facility as a QF.

## **SECTION 8 SECURITY AND CREDIT SUPPORT**

8.1 Project Development Security. Project Development Security is not required if Seller meets the Credit Requirements. Seller shall provide within five (5) Business Days from receipt of a written request from PacifiCorp all reasonable financial records necessary for PacifiCorp to confirm Seller satisfies the Credit Requirements.

8.1.1 Form and Amount of Project Development Security. If at any time Seller does not satisfy the Credit Requirements, then on or before the dates specified in Section 2.3(b)(i) and Section 2.3(b)(ii), respectively, Seller shall post and maintain in favor of PacifiCorp (a) a guaranty from a party that satisfies the Credit Requirements and in a form acceptable to PacifiCorp in its reasonable discretion, or (b) a Letter of Credit in favor of

PacifiCorp, in a form acceptable to PacifiCorp in its reasonable discretion, equal in each case to [REDACTED] of Expected Nameplate Capacity Rating (the “Project Development Security”). Seller and any party providing a guaranty for Seller shall provide within five (5) Business Days from receipt of a written request from PacifiCorp all reasonable financial records necessary for PacifiCorp to confirm Seller and/or the guarantor satisfies the Credit Requirements.

8.1.2 Use of Project Development Security to Pay Delay Damages. If the Commercial Operation Date occurs after the Scheduled Commercial Operation Date and Seller has failed to pay any Delay Damages when due under Section 2.5, PacifiCorp shall be entitled to and shall draw upon the Project Development Security an amount equal to the Delay Damages until such time as the Project Development Security is exhausted. PacifiCorp shall also be entitled to draw upon the Project Development Security for other damages if this Agreement is terminated under Section 11 because of Seller’s default.

8.1.3 Termination of Project Development Security. Seller shall no longer be required to maintain the Project Development Security (or the remaining balance thereof) after the Commercial Operation Date, if at such time no damages are owed to PacifiCorp under this Agreement. However, as of the Commercial Operation Date, Seller may elect to apply the Project Development Security toward the Default Security required by Section 8.2, including by the automatic continuation (as opposed to the replacement) thereof. PacifiCorp shall refund the Project Development Security within thirty (30) days of the Commercial Operation Date, unless the Seller elects to apply the Project Development Security toward Default Security as provided in this Section.

## 8.2 Default Security.

8.2.1 Duty to Post Default Security. Beginning on the date specified in Section 2.3(b), at any time during the Term when Seller does not satisfy the Credit Requirements, Seller shall post and maintain in favor of PacifiCorp (a) a guaranty from an entity that satisfies the Credit Requirements, in substantially the form attached hereto as Exhibit 8.2.1, or (b) a Letter of Credit (the “Default Security”), as provided in this Section 8.2. In the event Seller posts Default Security and thereafter satisfies the Credit Requirements, as demonstrated to the reasonable satisfaction of PacifiCorp, then Seller shall be entitled to a release by PacifiCorp of the Default Security for so long as Seller continues to satisfy the Credit Requirements. Seller and any party providing a guaranty for Seller shall provide within five (5) Business Days from receipt of a written request from PacifiCorp all reasonable financial records necessary for PacifiCorp to confirm Seller and/or the guarantor satisfies the Credit Requirements.

8.2.2 Amount of Default Security. The amount of the Default Security required by Section 8.2.1 shall be [REDACTED]

8.3 Levelized Security.

8.3.1 Duty to Post Levelized Security. If Seller has elected to receive levelized pricing, beginning on the dates specified in Section 2.2(c), at any time during the Term when Seller does not satisfy the Credit Requirements, Seller shall post and maintain in favor of PacifiCorp (a) a guaranty from an entity that satisfies the Credit Requirements, in a form acceptable to PacifiCorp in its reasonable discretion, or (b) a Letter of Credit (the “Levelized Security”), as provided in this Section 8.3. In the event Seller posts Levelized Security and thereafter satisfies the Credit Requirements, as demonstrated to the reasonable satisfaction of PacifiCorp, then Seller shall be entitled to a release by PacifiCorp of the Levelized Security for so long as Seller continues to satisfy the Credit Requirements. Seller and any party providing a guaranty for Seller shall provide within five (5) Business Days from receipt of a written request from PacifiCorp all reasonable financial records necessary for PacifiCorp to confirm Seller and/or the guarantor satisfies the Credit Requirements.

8.3.2 Amount of Levelized Security. The total amount of the Levelized Security required by Section 8.3.1 shall be the amount set forth in Exhibit 8.3.2 for each calendar year. On or before the Commercial Operation Date, Seller shall provide the Levelized Security for the applicable calendar year as set forth in Exhibit 8.3.2. Thereafter and throughout the Term, Seller shall provide for maintenance throughout the applicable calendar year the Levelized Security amount in Exhibit 8.3.2.

8.3.3 Duty of Levelized Security to Pay Amounts Due to PacifiCorp. If Seller fails to pay any amount due to PacifiCorp within the time provided for payment under this Agreement, PacifiCorp shall be entitled to and shall draw upon the Levelized Security. PacifiCorp shall also be entitled to draw upon the Levelized Security for damages arising if this Agreement is terminated under Section 11 because of Seller’s default.

8.4 Step In Rights.

8.4.1 Failure to Achieve Commercial Operation. If Seller fails to achieve Commercial Operation of the Facility by the Guaranteed Commercial Operation Date, PacifiCorp shall have the right to enter the Facility and do all such things as PacifiCorp may consider necessary or desirable to complete the Facility and cause Commercial Operation to occur. PacifiCorp shall, following the Commercial Operation Date (a) return the Facility to Seller upon execution of an indemnity and release by Seller of all claims arising out of the period of PacifiCorp’s entry on the Facility in a form reasonably acceptable to PacifiCorp or (b) failing the execution of such release or indemnity operate the Facility for the Term pursuant to Section 8.4.2. PacifiCorp shall likewise return the Facility to Seller upon a showing by Seller that it is immediately ready, willing and able to achieve Commercial Operation of the Facility within a commercially and technically reasonable period of time.

8.4.2 License to Operate Facility. Subject to the rights of a Lender under an applicable Lender Consent, Seller hereby irrevocably grants to PacifiCorp the right, license, and authority to enter the Premises, operate the Facility, and to perform Seller’s obligations hereunder for the Term during the continuance of an Event of Default by Seller under Sections 11.1.2(c), 11.1.2(e), 11.1.2(f), or 11.1.2(h) (such rights along with those rights set forth in

Section 8.4.1, “Step-In Rights”). PacifiCorp may, but shall not be obligated to, exercise its rights as licensee under this Section in lieu of termination. During any period in which PacifiCorp is operating the Facility pursuant to the license granted in this Section, Seller shall, upon request from PacifiCorp, reimburse PacifiCorp for all reasonable costs and expenses incurred by PacifiCorp to operate and maintain the Facility. Within ten (10) days following Seller’s cure of the Event of Default giving rise to PacifiCorp’s rights under this Section 8.4.2, PacifiCorp shall return custody of the Premises and the Facility to Seller.

8.4.3 Sole Remedy. For the avoidance of doubt, the entry onto the Premises by PacifiCorp under Sections 8.4.1 and 8.4.2 shall be in lieu of PacifiCorp exercising any other rights or remedies under this Agreement, including but not limited to its right to draw on any Default Security or Levelized Security, terminate this Agreement, or claim any other damages.

8.4.4 Rights of Lenders. The entry onto the Premises by PacifiCorp under section 8.4.1 or 8.4.2 shall be subject to the rights of Lenders as set forth in any applicable Lender Consent entered into by PacifiCorp with such Lenders. Such Lender Consent, among such other matters as it may address, shall provide that: (a) PacifiCorp shall give advance notice of twenty (20) days to Lenders of its intention to exercise its Step-In Rights; (b) PacifiCorp shall not exercise its Step-In Rights if a Lender notifies PacifiCorp that Lender is exercising remedies against Seller or otherwise will take reasonable measures, within ten (10) days, to cause Seller to promptly commence to correct the circumstances giving rise to the Step-In Rights; and (c) during the exercise of remedies by Lender against Seller, PacifiCorp may not exercise Step-In Rights until such time as the cure periods allowed to Seller, under this Agreement, and to Lender, under the Lender Consent, have run out.

8.4.5 Indemnification; Standard of Care. Seller shall indemnify and hold PacifiCorp harmless from and against all losses, costs, charges and expenses reasonably incurred by PacifiCorp in connection with exercise of its rights under Section 8.4.1 or 8.4.2 whether to third parties or otherwise, other than losses, costs, charges and expenses attributable to the gross negligence or willful misconduct of PacifiCorp. During such time as PacifiCorp has custody of the Premises and Facility pursuant to this Section 8.4, it shall conduct all of its activities pursuant to the standards of Prudent Electrical Practices.

8.4.6 Records and Access. Seller shall collect and have available at a convenient, central location at the Facility all documents, contracts, books, manuals, reports, and records required to construct, operate, and maintain the Facility in accordance with Prudent Electrical Practices. Upon PacifiCorp’s notice of intent to exercise Step-In Rights, PacifiCorp, its employees, contractors, or designated third parties shall have the right to enter the Premises and the Facility for the purpose of constructing or operating the Facility. Upon the exercise by PacifiCorp of the Step-In Rights, Seller shall cause the Facility operator (and any person within the control of Seller) to give PacifiCorp access to and control of the operation and maintenance of the Facility to the extent reasonably necessary to enable PacifiCorp to exercise the Step-In Rights in respect of the part of the Facility so to be operated by PacifiCorp, and shall provide reasonable assistance and cooperation to PacifiCorp to effect safely the transfer of operational responsibility as may be requested by PacifiCorp. Seller shall execute such documents and take such other action as may be necessary for PacifiCorp to effectuate its rights under this Section 8.4.6.

8.4.7 Return. PacifiCorp may, at any time, terminate its exercise of the Step-In Rights whether or not the applicable event has been cured. If at any time after exercising its Step-In Rights, PacifiCorp elects to return such possession to Seller, PacifiCorp shall provide Seller with at least ten (10) days advance notice of the date PacifiCorp intends to return such possession, and upon receipt of such notice Seller shall take all measures necessary to resume possession of the Facility on such date. Upon such return, the Event of Default giving rise to the Step-In-Rights shall be deemed to have been cured, and PacificCorp may not declare or give notice of a new Event of Default without providing any applicable notice and cure periods.

8.4.8 No Assumption. PacifiCorp's exercise of its Step-In Rights shall not be deemed an assumption by PacifiCorp of any liability of Seller due and owing prior to the exercise of such rights. PacifiCorp shall not assume any liability of Seller for the period during which PacifiCorp exercises its Step-In Rights. During any period that PacifiCorp is exercising its Step-In Rights, Seller shall retain legal title to and ownership of the Facility and all of its other property and its revenues. When exercising its Step-In Rights, PacifiCorp shall assume possession, operation, and control of the Facility solely as an agent for Seller. In no event shall PacifiCorp's election to exercise the Step-In Rights be deemed to constitute a transfer of ownership of or title to the Facility or any assets of Seller.

8.4.9 Costs and Expenses. Seller shall indemnify and hold harmless PacifiCorp from and against all reasonable losses, costs, charges and expenses incurred by PacifiCorp in connection with exercise of its Step-In Rights, other than losses, costs, charges and expenses attributable to the gross negligence or willful misconduct of PacifiCorp.

8.5 Annual Financial Statements. If requested by PacifiCorp from time to time, Seller shall within thirty (30) days provide PacifiCorp with copies of its most recent annual financial statements, which shall include the percentage of Facility Equity. For purposes of this Section, "Facility Equity" means the aggregate amount, as of the Commercial Operation Date, of equity investment in the Facility by any owner, investor, or other party, including, but not limited to, tax equity investors. The phrase "percentage of Facility Equity" means the ratio, expressed as a percentage, of the Facility Equity to the sum of (a) all indebtedness outstanding to third parties and (b) the amount of Facility Equity. No indebtedness relating to the Default Security described in SECTION 8 shall be included in the indebtedness described in clause (a) above.

8.6 Security is Not a Limit on Seller's Liability. The security contemplated by this Section 8 (a) constitutes security for, but is not a limitation of, Seller's obligations hereunder and (b) shall not be PacifiCorp's exclusive remedy for Seller's failure to perform in accordance with this Agreement. Seller shall maintain security as required by Sections 8.1, 8.2, and 8.3. To the extent that PacifiCorp draws on any security, Seller shall, on or before the first day of the Contract Year following such draw, replenish or reinstate the security to the full amount then required under this Section 8. If at any time the Seller or Seller's credit support provider(s) fails to meet the Credit Requirements, then Seller shall provide replacement security meeting the requirements set forth in this Section 8 within ten (10) Business Days after the earlier of (i) Seller's receipt of notice from any source that Seller or the credit support provider(s), as applicable, no longer meets the Credit Requirements or (ii) Seller's receipt of written notice from PacifiCorp requesting the posting of alternate security.



8.7 Senior Lender Protective Provisions. PacifiCorp agrees to enter into a consent to collateral assignment on commercially reasonable terms for the benefit of the Senior Lenders, and to reasonably cooperate with the reasonable requests of such Senior Lenders with respect to the provisions of such consent in conjunction with any financing of the Facility; provided, however, that Seller shall reimburse PacifiCorp for its reasonable out-of-pocket costs, with such costs to be paid to PacifiCorp at the closing of the financing as a condition to the effectiveness of PacifiCorp's consent.

## **SECTION 9 METERING**

9.1 Installation of Metering Equipment. Metering equipment shall be designed, furnished, installed, owned, inspected, tested, maintained and replaced as provided in the Generation Interconnection Agreement; provided, however, that PacifiCorp acting in its merchant function capacity shall be under no obligation, pursuant hereto, to bear any expense relating to such metering equipment.

9.2 Metering. Metering shall be performed at the location and in the manner specified in Exhibit 9.2, the Generation Interconnection Agreement and as necessary to perform Seller's obligations hereunder. All quantities of Net Output purchased hereunder shall reflect the net amount of energy flowing into the System at the Point of Delivery.

9.3 Inspection, Testing, Repair and Replacement of Meters. PacifiCorp shall have the right to periodically inspect, test, repair and replace the metering equipment that are provided for in the Generation Interconnection Agreement, without PacifiCorp assuming any obligations thereunder. If any of the inspections or tests disclose an error exceeding 0.5 percent, either fast or slow, proper correction, based upon the inaccuracy found, shall be made of previous readings for the actual period during which the metering equipment rendered inaccurate measurements if that period can be ascertained. If the actual period cannot be ascertained, the proper correction shall be made to the measurements taken during the time the metering equipment was in service since last tested, but not exceeding three (3) months, in the amount the metering equipment shall have been shown to be in error by such test. Any correction in billings or payments resulting from a correction in the meter records shall be made in the next monthly billing or payment rendered. Such correction, when made, shall constitute full adjustment of any claim between Seller and PacifiCorp arising out of such inaccuracy of metering equipment. Nothing in this Agreement shall give rise to PacifiCorp, acting in its merchant function capacity hereunder, having any obligations to Seller, or any other person or entity, pursuant to or under the Generation Interconnection Agreement.

9.4 Metering Costs. To the extent not otherwise provided in the Generation Interconnection Agreement, Seller shall bear all costs (including PacifiCorp's costs) relating to all metering equipment installed to accommodate Seller's Facility.

9.5 Meter Data. Within ten (10) days of the Effective Date, Seller may request the Interconnection Provider or Transmission Provider in writing in a form similar to that found in Exhibit 9.5 to provide any and all meter or other data associated with the Facility or Net Output directly to PacifiCorp. Should Seller refuse to provide a release similar to that found in Exhibit

9.5, Seller shall establish a mechanism at its expense that allows PacifiCorp, in its merchant function, to obtain all necessary meter and other data to fully perform and verify Seller's performance under this Agreement. Notwithstanding any other provision hereof, PacifiCorp shall have the right to provide such data to any Electric System Authority.

9.6 WREGIS Metering. Seller shall cause the Facility to implement all necessary generation information communications in WREGIS, and report generation information to WREGIS pursuant to a WREGIS-approved meter that is dedicated to the Facility and only the Facility.

## **SECTION 10 BILLINGS, COMPUTATIONS AND PAYMENTS**

10.1 Monthly Invoices. On or before the 10th day following the end of each calendar month, Seller shall deliver to PacifiCorp a proper invoice showing Seller's computation of Net Output delivered to the Point of Delivery during such month. When calculating the invoice, Seller shall provide computations showing the portion of Net Output that was delivered during On-Peak Hours and the portion of Net Output that was delivered during Off-Peak Hours. If such invoice is delivered by Seller to PacifiCorp, then PacifiCorp shall send to Seller, on or before the later of the 20th day following receipt of such invoice or the 30th day following the end of each month, payment for Seller's deliveries of Net Output to PacifiCorp.

10.2 Offsets. Either Party may offset any payment due hereunder against amounts owed by the other Party pursuant hereto. Either Party's exercise of recoupment and set off rights shall not limit the other remedies available to such Party hereunder.

10.3 Interest on Late Payments. Any amounts that are not paid when due hereunder shall bear interest at the Contract Interest Rate from the date due until paid.

10.4 Disputed Amounts. If either Party, in good faith, disputes any amount due pursuant to an invoice rendered hereunder, such Party shall notify the other Party of the specific basis for the dispute and, if the invoice shows an amount due, shall pay that portion of the statement that is undisputed, on or before the due date. Except with respect to invoices provided under Section 6.12.3, any such notice shall be provided within two (2) years of the date of the invoice in which the error first occurred. If any amount disputed by such Party is determined to be due the other Party, or if the Parties resolve the payment dispute, the amount due shall be paid within five (5) days after such determination or resolution, along with interest at the Contract Interest Rate from the date due until the date paid.

10.5 Audit Rights. Each Party, through its authorized representatives, shall have the right, at its sole expense upon reasonable notice and during normal business hours, to examine and copy the records of the other Party to the extent reasonably necessary to verify the accuracy of any statement, charge or computation made hereunder or to verify the other Party's performance of its obligations hereunder. Upon request, each Party shall provide to the other Party statements evidencing the quantities of Net Output delivered at the Point of Delivery. If any statement is found to be inaccurate, a corrected statement shall be issued and any amount due thereunder will be promptly paid and shall bear interest at the Contract Interest Rate from the

date of the overpayment or underpayment to the date of receipt of the reconciling payment. Notwithstanding the foregoing, no adjustment shall be made with respect to any statement or payment hereunder unless a Party questions the accuracy of such payment or statement within two (2) years after the date of such statement or payment.

## **SECTION 11 DEFAULTS AND REMEDIES**

11.1 Defaults. The following events are defaults (each a “default” before the passing of applicable notice and cure periods, and an “Event of Default” thereafter) hereunder:

### 11.1.1 Defaults by Either Party.

(a) A Party fails to make a payment when due hereunder if the failure is not cured within ten (10) days after the non-defaulting Party gives the defaulting Party a notice of the default.

(b) A Party (i) makes a general assignment for the benefit of its creditors; (ii) files a petition or otherwise commences, authorizes or acquiesces in the commencement of a proceeding or cause of action under any bankruptcy or similar law for the protection of creditors, or has such a petition filed against it and such petition is not withdrawn or dismissed within sixty (60) days after such filing; (iii) becomes insolvent; or (iv) is unable to pay its debts when due.

(c) Subject to the limitations set forth in Section 3.4, a Party breaches a representation or warranty made by it herein if the breach is not cured within thirty (30) days after the non-defaulting Party gives the defaulting Party a notice of the default; provided, however, that, upon written notice from the defaulting Party, this 30-day period shall be extended by an additional sixty (60) days if (i) the failure cannot reasonably be cured within the 30-day period despite diligent efforts, (ii) the default is capable of being cured within the additional 60-day period, and (iii) the defaulting Party commences the cure within the original 30-day period and is at all times thereafter diligently and continuously proceeding to cure the failure.

(d) A Party otherwise fails to perform any material obligation hereunder if the failure is not cured within thirty (30) days after the non-defaulting Party gives the defaulting Party notice of the default; provided, however, that, upon written notice from the defaulting Party, the 30-day period shall be extended by an additional sixty (60) days if (i) the failure cannot reasonably be cured within the 30-day period despite diligent efforts, (ii) the default is capable of being cured within the additional 60-day period, and (iii) the defaulting Party commences the cure within the original 30-day period and is at all times thereafter diligently and continuously proceeding to cure the failure.

### 11.1.2 Defaults by Seller.

(a) Seller fails to post, increase, or maintain the Project Development Security, Levelized Security or Default Security as required under, and by the applicable dates

**CONFIDENTIAL – SUBJECT TO UTAH PUBLIC SERVICE COMMISSION RULE 746-100-16**

set forth in, Section 2 and Section 8 and such failure continues for fifteen (15) days after Seller's receipt of written notice thereof from PacifiCorp.

(b) Seller fails to (i) cause the Facility to achieve Commercial Operation on or before the Guaranteed Commercial Operation Date, or (ii) complete all items included on the Final Completion Punch List within ninety (90) days after the Commercial Operation Date unless, if at any time on or before the last day of such period, Seller achieves Final Completion and has provided written notice to PacifiCorp that the Facility has achieved Final Completion at the Facility's current Nameplate Capacity Rating, whether or not all of the items of the Final Completion Punch list have been completed.

(c) Seller sells Output or Capacity Rights from the Facility to a party other than PacifiCorp in breach of Section 4.2, if Seller does not permanently cease such sale and compensate PacifiCorp for the damages arising from the breach within ten (10) days after PacifiCorp gives Seller a notice of default.

(d) PacifiCorp receives notice of foreclosure of the Facility or any part thereof by a Lender, mechanic or materialman, or any other holder, of an unpaid lien or other charge or encumbrance, if the same has not been stayed, paid, or bonded around within ten (10) days of the date of the notice received by PacifiCorp.

(e) After the Commercial Operation Date, Seller fails to maintain any Required Facility Documents or Permits necessary to own or operate the Facility and such failure continues for thirty (30) days after Seller's receipt of written notice thereof from PacifiCorp; provided, however, that, upon written notice from Seller, the 30-day period shall be extended by an additional sixty (60) days if (i) the failure cannot reasonably be cured within the 30-day period despite diligent efforts, (ii) the default is capable of being cured within the additional 60-day period, and (iii) Seller commences the cure within the original 30-day period and is at all times thereafter diligently and continuously proceeding to cure the failure.

(f) Seller's Abandonment of construction or operation of the Facility and such failure continues for thirty (30) days after Seller's receipt of written notice thereof from PacifiCorp, except to the extent caused by an event of Force Majeure or a default by PacifiCorp.

(g) Seller fails to maintain insurance as required by this Agreement and such failure continues for fifteen (15) days after Seller's receipt of written notice thereof from PacifiCorp.

(h) Seller fails to meet the Output Guarantee for three (3) consecutive years, and fails to pay applicable liquidated damages pursuant to Section 6.12.2.

**11.2 Remedies for Failure to Deliver/Receive.**

**11.2.1 Remedy for Seller's Failure to Deliver.** Upon the occurrence and during the continuation of a default of Seller under Section 11.1.2(c), Seller shall pay PacifiCorp within five (5) Business Days after invoice receipt, an amount equal to (a) PacifiCorp's Cost to Cover multiplied by the Net Output delivered to a party other than PacifiCorp, (b) additional transmission charges, if any, reasonably incurred by PacifiCorp in moving replacement energy to

the Point of Delivery or if not there, to such points in PacifiCorp's control area as are determined by PacifiCorp, and (c) any additional cost or expense incurred as a result of Seller's default under Section 11.1.2(c), as determined by PacifiCorp in a commercially reasonable manner (but not including any penalties, ratcheted demand or similar charges). The invoice for such amount shall include a written statement explaining in reasonable detail the calculation of such amount.

11.2.2 Remedy for PacifiCorp's Failure to Purchase. If PacifiCorp fails to receive or purchase all or part of the Net Output required to be purchased pursuant hereto and such failure is not excused under the terms hereof or by Seller's failure to perform, then Seller shall perform under Section 11.6 and PacifiCorp shall pay Seller, on the earlier of the date payment would otherwise be due in respect of the month in which the failure occurred or within five (5) Business Days after invoice receipt, an amount equal to Seller's Cost to Cover multiplied by the amount of Net Output so not purchased, less amounts received by Seller pursuant to Section 11.6. The invoice for such amount shall include a written statement explaining in reasonable detail the calculation thereof.

11.2.3 Remedy for Seller's Failure to Sell/Deliver Capacity Rights. Seller shall be liable for PacifiCorp's actual damages in the event Seller fails to sell or deliver all or any portion of the Capacity Rights to PacifiCorp.

11.3 Termination and Remedies. From and during the continuance of an Event of Default, the non-defaulting Party shall be entitled to all remedies available at law or in equity, and may terminate this Agreement by notice to the other Party designating the date of termination and delivered to the defaulting Party no less than fifteen (15) Business Days before such termination date. The notice required by this Section 11.3 may be provided in the notice of default (and does not have to be a separate notice) so long as it complies with all other terms of this Section 11.3. As a precondition to Seller's exercise of this termination right, Seller must also provide copies of such notice to the notice addresses of then-current President and General Counsel of PacifiCorp set forth in Section 22. Such copies shall be sent by registered overnight delivery service or by certified or registered mail, return receipt requested. In addition, Seller's termination notice shall state prominently therein in typefont no smaller than 14-point all-capital letters that "THIS IS A TERMINATION NOTICE UNDER A SOLAR PPA. YOU MUST CURE A DEFAULT, OR THE PPA WILL BE TERMINATED," and shall state therein any amount purported to be owed and wiring instructions. Seller will not have any right to terminate this Agreement if the default that gave rise to the termination right is cured within fifteen (15) Business Days of receipt of such notice. Further, from and after the date upon which Seller fails to remedy a default within the time periods provided in Section 11.1, and until PacifiCorp has recovered all damages incurred on account of such default by Seller, without exercising its termination right, PacifiCorp may offset its damages against any payment due Seller. Except in circumstances in which a remedy provided for in this Agreement is described as a Party's sole or exclusive remedy, upon termination, the non-defaulting Party may pursue any and all legal or equitable remedies provided by law, equity or this Agreement (including Section 24.5). The rights contemplated by this Section 11 are cumulative such that the exercise of one or more rights shall not constitute a waiver of any other rights. In the event of a termination hereof:

(a) Each Party shall pay to the other all amounts due the other hereunder for all periods prior to termination, subject to offset by the non-defaulting Party against damages incurred by such Party.

(b) The amounts due pursuant to Section 11.3(a) shall be calculated and paid within thirty (30) days after the billing date for such charges and shall bear interest thereon at the Contract Interest Rate from the date of termination until the date paid. The foregoing does not extend the due date of, or provide an interest holiday for any payments otherwise due hereunder.

(c) Before and after the effective date of termination, the non-defaulting Party may pursue, to the extent permitted by this Agreement, any and all legal or equitable remedies provided by law, equity or this Agreement (including Section 24.6).

(d) Without limiting the generality of the foregoing, the provisions of Sections 4.5, 5.4, 5.5, 6.10.4, 6.10.5, 6.10.7, 10.3, 10.4, 10.5, 11.3, 11.4, 11.5, 11.6, 11.7, 11.8, and Section 12, Section 13, Section 23, and Section 24 shall survive the termination hereof to the extent necessary to comply with or verify compliance by the Parties with the requirements of this Agreement.

11.4 Termination of Duty to Buy. If this Agreement is terminated following the Commercial Operation Date because of a default by Seller, neither Seller (or any Affiliate), nor any successor to Seller with respect to the ownership of the Facility or Premises, may thereafter require or seek to require PacifiCorp to enter into a power purchase agreement or otherwise purchase energy or capacity from the Facility or any facility constructed on the Premises under PURPA, or any other Requirements of Law, for any periods that would have been within the Term had this Agreement remained in effect; provided, however, that such prohibition on seeking or requiring PacifiCorp to enter into a power purchase agreement or otherwise purchase energy or capacity as described above shall not apply in the event that any proposed replacement agreement incorporates the Contract Price attached hereto as Exhibit 5.1. If this Agreement is terminated prior to the Commercial Operation Date because of a default by Seller, for a period of two (2) years following the date of such termination, neither Seller (or any Affiliate), nor any successor to Seller with respect to the ownership of the Facility or Premises, may thereafter require or seek to require PacifiCorp to enter into a power purchase agreement or otherwise purchase energy or capacity from the Facility or any facility constructed on the Premises under PURPA or any other Requirements of Law using any Contract Price other than that provided in Exhibit 5.1 attached hereto. Following this two year period, Seller, Affiliate or successor to Seller may seek a new power purchase agreement with PacifiCorp for the Facility or for a facility to be constructed on the Premises, though PacifiCorp shall not be obligated to provide in such power purchase agreement avoided cost prices that are higher than the avoided cost prices contained in this Agreement for any sales of energy or capacity to PacifiCorp under that power purchase agreement prior to the expiration of five (5) years from the date this Agreement is terminated as a result of Seller's default. The parties agree that a termination of this Agreement due to the failure of the Seller to obtain a governmental approval or authorization for the Facility or Premises or a legal challenge brought by a third party to a governmental approval or authorization that has been granted for the Facility or Premises that causes prospective Lenders to refuse to provide financing for the construction of the Facility shall not be considered to be a

default of the Seller for purposes of this Section 11.4 only. The Seller shall use commercially reasonable efforts and act consistent with the terms of this Agreement in obtaining all government approvals and authorizations and in participating in any legal challenge in an effort to sustain any governmental approval or authorization for the Facility or Premises. Further, Seller shall use commercially reasonable efforts to obtain financing. On or before the Effective Date, the Parties shall execute and record, in the appropriate real property records of the counties in which the Facility or Premises is situated, and any federal agency as applicable, a memorandum in the form of Exhibit 11.4 to provide constructive notice to third parties of Seller's agreements under this Section 11.4.

11.5 Termination Damages. If this Agreement is terminated as a result of an Event of Default by one of the Parties, termination damages shall be determined as described in Section 11.2 herein. The amount of termination damages shall be calculated by the non-defaulting Party within a reasonable period after termination of the Agreement. Amounts owed pursuant to this section shall be due within five (5) Business Days after the non-defaulting Party gives the defaulting Party notice of the amount due. The non-defaulting Party shall under no circumstances be required to account for or otherwise credit or pay the defaulting Party for economic benefits accruing to the non-defaulting Party as a result of the defaulting Party's default.

11.6 Duty/Right to Mitigate. Each Party agrees that it has a duty to mitigate damages and covenants that it will use commercially reasonable efforts to minimize any damages it may incur as a result of the other Party's performance or non-performance hereof. "Commercially reasonable efforts" (a) by Seller shall include requiring Seller to use commercially reasonable efforts to maximize the price for Net Output received by Seller from third parties, including entering into an enabling agreement with, or being affiliated with, one or more power marketers of nationally recognized standing to market such Net Output not purchased or accepted by PacifiCorp (only during a period PacifiCorp is in default), (b) by PacifiCorp shall include requiring PacifiCorp to use commercially reasonable efforts to minimize the price paid to third parties for energy purchased to replace Net Output not delivered by Seller as required hereunder.

11.7 Security. If this Agreement is terminated because of Seller's default, PacifiCorp may, in addition to pursuing any and all other remedies available at law or in equity, proceed against any security held by PacifiCorp in whatever form to reduce any amounts that Seller owes PacifiCorp arising from such default.

11.8 Cumulative Remedies. Except in circumstances in which a remedy provided for in this Agreement is described as a sole or exclusive remedy, the rights and remedies provided to PacifiCorp hereunder are cumulative and not exclusive of any rights or remedies of PacifiCorp.

## **SECTION 12 INDEMNIFICATION AND LIABILITY**

### 12.1 Indemnities.

12.1.1 Indemnity by Seller. To the extent permitted by Requirements of Law and subject to Section 12.1.5, Seller shall release, indemnify and hold harmless PacifiCorp, its

divisions, Affiliates, and each of its and their respective directors, officers, employees, agents, and representatives (collectively, the “PacifiCorp Indemnitees”) against and from any and all losses, fines, penalties, claims, demands, damages, liabilities, actions or suits of any nature whatsoever (including legal costs and attorneys’ fees, both at trial and on appeal, whether or not suit is brought) (collectively, “Liabilities”) actually or allegedly resulting from, or arising out of, or in any way connected with, the performance by Seller of its obligations hereunder, or relating to the Facility or Premises, for or on account of injury, bodily or otherwise, to, or death of, or damage to, or destruction or economic loss of property of, any person or entity, excepting only to the extent such Liabilities as may be caused by the gross negligence or willful misconduct of any person or entity within the PacifiCorp Indemnitees or by Seller’s compliance with Requirements of Law. Seller shall be solely responsible for (and shall defend and hold PacifiCorp harmless against) any damage that may occur as a direct result of Seller’s breach of the Generation Interconnection Agreement.

12.1.2 Indemnity by PacifiCorp. To the extent permitted by Requirements of Law and subject to Section 12.1.5, PacifiCorp shall release, indemnify and hold harmless Seller, its Affiliates, and each of its and their respective directors, officers, employees, agents, and representatives (collectively, the “Seller Indemnitees”) against and from any and all Liabilities actually or allegedly resulting from, or arising out of, or in any way connected with, the performance by PacifiCorp of its obligations hereunder for or on account of (a) injury, bodily or otherwise, to, or death of, or (b) for damage to, or destruction or economic loss of property of, any person or entity within the Seller Indemnitees, excepting only to the extent such Liabilities as may be caused by the gross negligence or willful misconduct of any person or entity within the Seller Indemnitees.

12.1.3 Additional Cross Indemnity. Without limiting Sections 12.1.1 and 12.1.2, Seller shall release, indemnify and hold harmless the PacifiCorp Indemnitees from and against all Liabilities related to Net Output prior to its delivery by Seller at the Point of Delivery, and PacifiCorp shall release, indemnify and hold harmless the Seller Indemnitees from and against all Liabilities related to Net Output once delivered to PacifiCorp at the Point of Delivery as provided herein, except in each case to the extent such Liabilities are attributable to the gross negligence or willful misconduct or a breach of this Agreement by any member of the PacifiCorp Indemnitees or the Seller Indemnitees, respectively, seeking indemnification hereunder.

12.1.4 No Dedication. Nothing herein shall be construed to create any duty to, any standard of care with reference to, or any liability to any person not a Party. No undertaking by one Party to the other under any provision hereof shall constitute the dedication of PacifiCorp’s facilities or any portion thereof to Seller or to the public, nor affect the status of PacifiCorp as an independent public utility corporation or Seller as an independent individual or entity.

12.1.5 Consequential Damages. EXCEPT TO THE EXTENT SUCH DAMAGES ARE INCLUDED IN ANY LIQUIDATED DAMAGES, DELAY DAMAGES, PACIFICORP AND SELLER COST TO COVER DAMAGES, SECTION 11.2.3 CAPACITY RIGHTS LOSS DAMAGES, INDEMNIFICATION FOR THIRD PARTY DAMAGES, OR OTHER SPECIFIED MEASURE OF DAMAGES EXPRESSLY PROVIDED FOR HEREIN, NEITHER PARTY SHALL BE LIABLE TO THE OTHER PARTY FOR SPECIAL,



PUNITIVE, INDIRECT, EXEMPLARY OR CONSEQUENTIAL DAMAGES, WHETHER SUCH DAMAGES ARE ALLOWED OR PROVIDED BY CONTRACT, TORT (INCLUDING NEGLIGENCE), STRICT LIABILITY, STATUTE OR OTHERWISE.

### **SECTION 13 INSURANCE**

13.1 Required Policies and Coverages. Without limiting any liabilities or any other obligations of Seller hereunder, Seller shall secure and continuously carry the insurance coverage specified on Exhibit 13 during the Term or longer period if specified in Exhibit 13.

### **SECTION 14 FORCE MAJEURE**

14.1 Definition of Force Majeure. “Force Majeure” or “an event of Force Majeure” means an event that (a) is not reasonably anticipated as of the date hereof, (b) is not within the reasonable control of the Party affected by the event, (c) is not the result of such Party’s negligence or failure to act, and (d) could not be overcome by the affected Party’s use of due diligence in the circumstances. Force Majeure includes, but is not restricted to, events of the following types (but only to the extent that such an event, in consideration of the circumstances, satisfies the tests set forth in the preceding sentence): acts of God; civil disturbance; sabotage; strikes; lock-outs; work stoppages; action or restraint by court order or public or government authority (as long as the affected Party has not applied for or assisted in the application for, and has opposed to the extent reasonable, such court or government action). Notwithstanding the foregoing, none of the following constitute Force Majeure: (i) Seller’s ability to sell, or PacifiCorp’s ability to purchase energy or capacity at a more advantageous price than is provided hereunder; (ii) the cost or availability of fuel or motive force to operate the Facility; (iii) economic hardship, including lack of money; (iv) any breakdown or malfunction of the Facility’s equipment (including any serial equipment defect) that is not caused by an independent event of Force Majeure, (v) the imposition upon a Party of costs or taxes allocated to such Party under Section 5, (vi) delay or failure of Seller to obtain or perform any Required Facility Document unless due to a Force Majeure event, (vii) any delay, alleged breach of contract, or failure by the Transmission Provider, Network Service Provider or Interconnection Provider unless due to a Force Majeure event, (viii) maintenance upgrade or repair of any facilities or right of way corridors constituting part of or involving the Interconnection Facilities, whether performed by or for Seller, or other third parties (except for repairs made necessary as a result of an event of Force Majeure); (ix) Seller’s failure to obtain, or perform under, the Generation Interconnection Agreement, or its other contracts and obligations to transmission owner, Transmission Provider or Interconnection Provider, unless due to a Force Majeure event; or (x) any event attributable to the use of Interconnection Facilities for deliveries of Net Output to any party other than PacifiCorp. Notwithstanding anything to the contrary herein, in no event will the increased cost of electricity, steel, labor, or transportation constitute an event of Force Majeure.

14.2 Suspension of Performance. Neither Party shall be liable for any delay or failure in its performance under this Agreement, nor shall any delay, failure, or other occurrence or event become an Event of Default, to the extent such delay, failure, occurrence or event is substantially caused by conditions or events of Force Majeure during the continuation of the

event of Force Majeure, for the same number of days that the event of Force Majeure has prevailed, provided that:

(a) the Party affected by the Force Majeure, shall, within five (5) days after the occurrence of the event of Force Majeure, give the other Party written notice describing the particulars of the event; and

(b) the suspension of performance shall be of no greater scope and of no longer duration than is required to remedy the effect of the Force Majeure; and

(c) the affected Party shall use diligent efforts to remedy its inability to perform.

14.3 Force Majeure Does Not Affect Other Obligations. No obligations of either Party that arose before the Force Majeure causing the suspension of performance or that arise after the cessation of the Force Majeure shall be excused by the Force Majeure.

14.4 Strikes. Notwithstanding any other provision hereof, neither Party shall be required to settle any strike, walkout, lockout or other labor dispute on terms which, in the sole judgment of the Party involved in the dispute, are contrary to the Party's best interests.

14.5 Right to Terminate. If a Force Majeure event prevents a Party from substantially performing its obligations hereunder for a period exceeding one hundred eighty (180) consecutive days prior to the Commercial Operation Date or, after the Commercial Operation Date, for a period exceeding two hundred ten (210) consecutive days (despite the affected Party's effort to take all reasonable steps to remedy the effects of the Force Majeure with all reasonable dispatch), then the Party not affected by the Force Majeure event, with respect to its obligations hereunder, may terminate this Agreement by giving ten (10) days' prior notice to the other Party. Upon such termination, neither Party will have any liability to the other with respect to the period following the effective date of such termination; provided, however, that this Agreement will remain in effect to the extent necessary to facilitate the settlement of all liabilities and obligations arising hereunder before the effective date of such termination.

## **SECTION 15 SEVERAL OBLIGATIONS**

Nothing contained herein shall be construed to create an association, trust, partnership or joint venture or to impose a trust, partnership or fiduciary duty, obligation or liability on or between the Parties.

## **SECTION 16 CHOICE OF LAW**

This Agreement shall be interpreted and enforced in accordance with the laws of the state of Utah, applying any choice of law rules that may direct the application of the laws of another jurisdiction.

**SECTION 17  
PARTIAL INVALIDITY**

The Parties do not intend to violate any laws governing the subject matter hereof. If any of the terms hereof are finally held or determined to be invalid, illegal or void as being contrary to any applicable law or public policy, all other terms hereof shall remain in effect. The Parties shall use best efforts to amend this Agreement to reform or replace any terms determined to be invalid, illegal or void, such that the amended terms (a) comply with and are enforceable under applicable law, (b) give effect to the intent of the Parties in entering hereinto, and (c) preserve the balance of the economics and equities contemplated by this Agreement in all material respects.

**SECTION 18  
NON-WAIVER**

No waiver of any provision hereof shall be effective unless the waiver is set forth in a writing that (a) expressly identifies the provision being waived, and (b) is executed by the Party waiving the provision. A Party's waiver of one or more failures by the other Party in the performance of any of the provisions hereof shall not be construed as a waiver of any other failure or failures, whether of a like kind or different nature.

**SECTION 19  
GOVERNMENTAL JURISDICTION  
AND AUTHORIZATIONS**

This Agreement is subject to the jurisdiction of those Governmental Authorities having control over either Party or this Agreement. During the Term, Seller shall maintain all Permits required, as applicable, for the construction, operation, or ownership of the Facility.

**SECTION 20  
SUCCESSORS AND ASSIGNS**

20.1 Restriction on Assignments. Except as expressly provided in this Section 20, neither Party may assign this Agreement or any of its rights or obligations hereunder without the prior written consent of the other Party, which shall not be unreasonably withheld.

20.2 Permitted Assignments. Notwithstanding Section 20.1, either Party may, without the need for consent from the other Party (but with notice to the other Party, including the names of the assignees): (a) transfer, sell, pledge, encumber or assign this Agreement or the accounts, revenues or proceeds therefrom in connection with project financing for the Facility; (b) transfer or assign this Agreement to an Affiliate of such Party; or (c) transfer or assign this Agreement to any party succeeding to all or substantially all of the assets or generating assets of such Party (and, with respect to Seller, Seller shall be required to transfer or assign this Agreement to any party succeeding to all or substantially all of the assets of Seller); provided, however, that Seller shall not transfer, sell, encumber or assign this Agreement or any interest herein to any Affiliate of PacifiCorp without the prior written consent of PacifiCorp. Except with respect to collateral assignments for financing purposes in every assignment permitted under this Section 20.2, the assignee must agree in writing to be bound by the terms and conditions hereof and must possess

the same or similar experience, and possess the same or better creditworthiness, as the assignor. PacifiCorp may assign this Agreement in whole or in part without the consent of Seller to any person or entity in the event that PacifiCorp ceases to be a load-serving entity, in which event PacifiCorp shall be released from liability hereunder upon approval of PacifiCorp ceasing to be a load-serving entity by the Commission. The Party seeking to assign or transfer this Agreement shall be solely responsible for paying all costs of assignment.

**SECTION 21  
ENTIRE AGREEMENT**

This Agreement supersedes all prior agreements, proposals, representations, negotiations, discussions or letters, whether oral or in writing, regarding the subject matter hereof. No modification hereof shall be effective unless it is in writing and executed by both Parties.

**SECTION 22  
NOTICES**

22.1 Addresses and Delivery Methods. All notices, requests, statements or payments shall be made to the addresses set out below. In addition, copies of a notice of termination of this Agreement under Section 11.3 shall contain the information required by Section 11.3 and shall be sent to the then-current President and General Counsel of PacifiCorp. Notices required to be in writing shall be delivered by letter, facsimile or other tangible documentary form. Notice by overnight mail or courier shall be deemed to have been given on the date and time evidenced by the delivery receipt. Notice by hand delivery shall be deemed to have been given when received or hand delivered. Notice by facsimile is effective as of transmission to each and all of the telefacsimile numbers provided below for a Party, but must be followed up by notice by registered mail or overnight carrier to be effective. Notice by overnight mail shall be deemed to have been given the Business Day after it is sent, if sent for next day delivery to a domestic address by a recognized overnight delivery service (e.g., Federal Express or UPS). Notice by certified or registered mail, return receipt requested, shall be deemed to have been given upon receipt.

To Seller:

Utah Red Hills Renewable Park, LLC  
2320 Marinship Way, Suite 300  
Sausalito, California 94965  
Attn: Luigi Resta

with a copy to:

Ballard Spahr LLP  
201 South Main, Suite 800  
Salt Lake City, Utah 84111  
Attn: Jerold G. Oldroyd

To PacifiCorp: PacifiCorp  
825 NE Multnomah, Suite 2000  
Portland, Oregon 97232- 2315  
Attn: Sr. Vice President, Commercial & Trading  
Telefacsimile (503) 813-6260

with a copy to: PacifiCorp  
825 NE Multnomah, Suite 600  
Portland, Oregon 97232- 2315  
Attn: Manager of Contract Administration, C&T  
Telefacsimile (503) 813-6291

with copies to: PacifiCorp Energy Legal Department  
825 NE Multnomah, Suite 600  
Portland, Oregon 97232- 2315  
Attn: Assistant General Counsel  
Telefacsimile (503) 813-6761

and termination notices to PacifiCorp: PacifiCorp Energy  
1407 West North Temple, Suite 320  
Salt Lake City, Utah 84116  
Attn: President

and to: PacifiCorp Energy  
1407 West North Temple, Suite 320  
Salt Lake City, Utah 84116  
Attn: General Counsel

22.2 Changes of Address. The Parties may change any of the persons to whom notices are addressed, or their addresses, by providing written notice in accordance with this Section.

22.3 Notices to Senior Lenders. The requirements concerning notice by PacifiCorp to Senior Lenders, if any, shall be set forth in an applicable Lender Consent.

### **SECTION 23 CONFIDENTIALITY**

23.1 Confidential Business Information. The following constitutes “Confidential Business Information,” whether oral or written: (a) the Parties’ proposals and negotiations concerning this Agreement, made or conducted prior to the Effective Date, (b) the actual charges billed to PacifiCorp hereunder, (c) information provided by Seller contained in periodic reports, including but not limited to those described in Section 6.10.1 and 6.11, and (d) any information delivered by PacifiCorp to Seller prior to the Effective Date relating to the market prices of energy and methodologies for their determination or estimation. Seller and PacifiCorp each agree to hold such Confidential Business Information wholly confidential, except as otherwise expressly provided in this Agreement. “Confidential Business Information” shall not include information that (i) is in or enters the public domain through no fault of the Party receiving such

information, or (ii) was in the possession of a Party prior to the Effective Date, other than through delivery thereof as specified in subsections (a) and (c) above. A Party providing any Confidential Business Information under this Agreement shall clearly mark all pages of all documents and materials to be treated as Confidential Business information with the term “Confidential” on the front of each page, document or material. If the Confidential Business Information is transmitted by electronic means the title or subject line shall indicate the information is Confidential Business Information. All Confidential Business Information shall be maintained as confidential, pursuant to the terms of this Section 23, for a period of two (2) years from the date it is received by the receiving Party unless otherwise agreed to in writing by the Parties.

23.2 Duty to Maintain Confidentiality. Each Party agrees not to disclose Confidential Business Information to any other person (other than its Affiliates, accountants, auditors, counsel, consultants, lenders, prospective lenders, employees, officers and directors), without the prior written consent of the other Party, provided that: (a) either Party may disclose Confidential Business Information, if and to the extent such disclosure is required (i) by Requirements of Law, (ii) in order for PacifiCorp to receive regulatory recovery of expenses related to this Agreement, (iii) pursuant to an order of a court or regulatory agency, or (iv) in order to enforce this Agreement or to seek approval hereof, and (b) notwithstanding any other provision hereof, PacifiCorp may in its sole discretion disclose or otherwise use for any purpose in its sole discretion the Confidential Business Information described in Sections 23.1(b) or 23.1(c). In the event a Party is required by Requirements of Law to disclose Confidential Business Information, such Party shall to the extent possible promptly notify the other Party of the obligation to disclose such information.

23.3 PacifiCorp Regulatory Compliance. The Parties acknowledge that PacifiCorp is required by law or regulation to report certain information that is or could otherwise embody Confidential Business Information from time to time. Such reports include models, filings, reports of PacifiCorp’s net power costs, general rate case filings, power cost adjustment mechanisms, FERC-required reporting such as those made on FERC Form 1, Form 12, or Form 714, market power and market monitoring reports, annual state reports that include resources and loads, integrated resource planning reports, reports to entities such as NERC, WECC, Pacific Northwest Utility Coordinating Committee, WREGIS, or similar or successor organizations, forms, filings, or reports, the specific names of which may vary by jurisdiction, along with supporting documentation. Additionally, in regulatory proceedings in all state and federal jurisdictions in which it does business, PacifiCorp will from time to time be required to produce Confidential Business Information. PacifiCorp may use its business judgment in its compliance with all of the foregoing and the appropriate level of confidentiality it seeks for such disclosures. PacifiCorp may submit Confidential Business Information in regulatory proceedings without notice to Seller so long as PacifiCorp treats such Confidential Business Information consistent with its normal treatment of confidential customer information

23.4 Irreparable Injury; Remedies. Each Party agrees that violation of the terms of this Section 23 constitutes irreparable harm to the other, and that the harmed Party may seek any and all remedies available to it at law or in equity, including injunctive relief.

23.5 News Releases and Publicity. Except as otherwise provided in Section 6.14, before either Party issues any news release or publicly distributed promotional material regarding the Facility that mentions the Facility, such Party shall first provide a copy thereof to the other Party for its review and approval. Any use of either Party's name in such news release or promotional material must adhere to such Party's publicity guidelines then in effect; any use of Berkshire Hathaway's name requires PacifiCorp's prior written consent.

## **SECTION 24 DISAGREEMENTS**

24.1 Negotiations. The Parties shall attempt in good faith to resolve all disputes arising out of, related to or in connection with this Agreement promptly by negotiation, as follows. Any Party may give the other Party written notice of any dispute not resolved in the normal course of business. Executives of both Parties at levels one level above the personnel who have previously been involved in the dispute shall meet at a mutually acceptable time and place within ten (10) days after delivery of such notice, and thereafter as often as they reasonably deem necessary, to exchange relevant information and to attempt to resolve the dispute. All negotiations pursuant to this clause are confidential.

24.2 Arbitration. If any dispute cannot be resolved by negotiations as set forth in Section 24.1 above, within thirty (30) days after the referral of the dispute to such senior executives, or if no meeting of such senior executives has taken place within fifteen (15) days after such referral, the Parties may elect to pursue arbitration pursuant to the rules of the American Arbitration Association, or any other method chosen by the Parties, subject to the express written agreement of both Parties. Such written agreement shall include all guidelines to be followed by the Parties in such arbitration. Neither party shall be obligated to pursue arbitration over any other method of dispute resolution.

24.3 Additional Legal Remedies. In the event the Parties are unable to satisfactorily resolve the dispute within sixty (60) days from the receipt of notice of the dispute, and the Parties have not elected to pursue arbitration as described herein, subject to any extensions of time as may be mutually agreed upon in writing, or any arbitration agreement, either Party may initiate any legal remedies available to the Party.

24.4 Place of Contract Formation; Choice of Forum. Seller and PacifiCorp acknowledge and agree that this Agreement has been made and entered into as of the date executed by both Parties in Salt Lake City, Utah. Each Party irrevocably consents and agrees that any legal action or proceeding arising out of this Agreement or the actions of the Parties leading up to this Agreement shall be brought exclusively in the United States District Court for the District of Utah in Salt Lake City, Utah, or if such court does not have jurisdiction, in the 3<sup>rd</sup> Judicial District (Salt Lake County) Court of the state of Utah. By execution and delivery hereof, each Party (a) accepts the exclusive jurisdiction of such court and waives any objection that it may now or hereafter have to the exercise of personal jurisdiction by such court over each Party for the purpose of any proceeding related to this Agreement, (b) irrevocably agrees to be bound by any final judgment (after any and all appeals) of any such court arising out of such documents or actions, (c) irrevocably waives, to the fullest extent permitted by law, any objection that it may now or hereafter have to the laying of venue of any suit, action or

proceedings arising out of such documents brought in such court (including any claim that any such suit, action or proceeding has been brought in an inconvenient forum) in connection herewith, and), (d) agrees that service of process in any such action may be effected by mailing a copy thereof by registered or certified mail, postage prepaid, to such Party at its address as set forth herein, and (e) agrees that nothing herein shall affect the right to effect service of process in any other manner permitted by law.

24.5 Settlement Discussions. No statements of position or offers of settlement made in the course of the dispute process described in this Section will be offered into evidence for any purpose in any litigation between the Parties, nor will any such statements or offers of settlement be used in any manner against either Party in any such litigation. Further, no such statements or offers of settlement shall constitute an admission or waiver of rights by either Party in connection with any such litigation. At the request of either Party, any such statements and offers of settlement, and all copies thereof, shall be promptly returned to the Party providing the same.

24.6 Waiver of Jury Trial. EACH PARTY KNOWINGLY, VOLUNTARILY, INTENTIONALLY AND IRREVOCABLY WAIVES THE RIGHT TO A TRIAL BY JURY IN RESPECT OF ANY LITIGATION BASED ON THIS AGREEMENT, OR ARISING OUT OF, UNDER OR IN CONNECTION WITH THIS AGREEMENT AND ANY AGREEMENT EXECUTED OR CONTEMPLATED TO BE EXECUTED IN CONJUNCTION WITH THIS AGREEMENT, OR ANY COURSE OF CONDUCT, COURSE OF DEALING, STATEMENTS (WHETHER VERBAL OR WRITTEN) OR ACTIONS OF ANY PARTY HERETO. THIS PROVISION IS A MATERIAL INDUCEMENT TO EACH OF THE PARTIES FOR ENTERING HEREINTO. EACH PARTY HEREBY WAIVES ANY RIGHT TO CONSOLIDATE ANY ACTION, PROCEEDING OR COUNTERCLAIM ARISING OUT OF OR IN CONNECTION WITH THIS AGREEMENT OR ANY OTHER AGREEMENT EXECUTED OR CONTEMPLATED TO BE EXECUTED IN CONJUNCTION WITH THIS AGREEMENT, OR ANY MATTER ARISING HEREUNDER OR THEREUNDER, WITH ANY PROCEEDING IN WHICH A JURY TRIAL HAS NOT OR CANNOT BE WAIVED.

IN WITNESS WHEREOF, the Parties have caused this Agreement to be executed in their respective names as of the date last written below.

Utah Red Hills Renewable Park, LLC

PACIFICORP

By: \_\_\_\_\_

By: \_\_\_\_\_

Name: \_\_\_\_\_

Name: Bruce Griswold \_\_\_\_\_

Title: \_\_\_\_\_

Title: Director, Short Term Origination and QF Contracts

Date: \_\_\_\_\_

Date: \_\_\_\_\_







**EXHIBIT B**

**NERC EVENT TYPES**

Event Type	Description of Outages
U1 <sup>19</sup>	<u>Unplanned (Forced) Outage—Immediate</u> – An outage that requires immediate removal of a unit from service, another outage state or a Reserve Shutdown state. This type of outage results from immediate mechanical/electrical/hydraulic control systems trips and operator-initiated trips in response to unit alarms.
U2 <sup>1</sup>	<u>Unplanned (Forced) Outage—Delayed</u> – An outage that does not require immediate removal of a unit from the in-service state but requires removal within six (6) hours. This type of outage can only occur while the unit is in service.
U3 <sup>1</sup>	<u>Unplanned (Forced) Outage—Postponed</u> – An outage that can be postponed beyond six hours but requires that a unit be removed from the in-service state before the end of the next weekend. This type of outage can only occur while the unit is in service.
SF <sup>1</sup>	<u>Startup Failure</u> – An outage that results from the inability to synchronize a unit within a specified startup time period following an outage or Reserve Shutdown. A startup period begins with the command to start and ends when the unit is synchronized. An SF begins when the problem preventing the unit from synchronizing occurs. The SF ends when the unit is synchronized or another SF occurs.
MO	<u>Maintenance Outage</u> – An outage that can be deferred beyond the end of the next weekend, but requires that the unit be removed from service before the next planned outage. (Characteristically, a MO can occur any time during the year, has a flexible start date, may or may not have a predetermined duration and is usually much shorter than a PO.)
ME	<u>Maintenance Outage Extension</u> – An extension of a maintenance outage (MO) beyond its estimated completion date. This is typically used where the original scope of work requires more time to complete than originally scheduled. Do not use this where unexpected problems or delays render the unit out of service beyond the estimated end date of the MO.
PO	<u>Planned Outage</u> – An outage that is scheduled well in advance and is of a predetermined duration, lasts for several weeks and occurs only once or twice a year. (Boiler overhauls, Solar Array replacement or inspections are typical planned outages.)
PE	<u>Planned Outage Extension</u> – An extension of a planned outage (PO) beyond its estimated completion date. This is typically used where the original scope of work requires more time to complete than originally scheduled. Do not use this where unexpected problems or delays render the unit out of service beyond the estimated end date of the PO.

<sup>19</sup> These event types are all contributors to the FOR & EFOR calculations in the reports section.

**EXHIBIT C**

**EXAMPLE OF CALCULATION OF DELAY DAMAGES**

For the purposes of this example only, assume the following:

(Note: These assumptions are illustrative only. Actual terms are as defined in this Agreement)

Expected Energy = 652,746 MWhs

PacifiCorp’s Cost to Cover = as set forth in the table below

Scheduled Commercial Operation Date: April 1, 2011

Date on which Delay Damages begin to accrue: April 1, 2011

Actual Commercial Operation Date: June 1, 2011

	A	B
DATE	PacifiCorp’s Cost to Cover	Delay Damages (A X 652,746 /365)
Saturday April 2, 2011	\$14.15	\$25,305.08
Sunday April 3, 2011	\$20.90	\$37,376.41
Monday April 4, 2011	\$13.90	\$24,858.00
Tuesday April 5, 2011	\$16.15	\$28,881.78
Wednesday April 6, 2011	\$16.15	\$28,881.78
Thursday April 7, 2011	\$14.90	\$26,646.34
Friday April 8, 2011	\$17.15	\$30,670.12
Saturday April 9, 2011	\$23.15	\$41,400.19
Sunday April 10, 2011	\$19.90	\$35,588.07
Monday April 11, 2011	\$11.90	\$21,281.31
Tuesday April 12, 2011	\$12.90	\$23,069.65
Wednesday April 13, 2011	\$12.90	\$23,069.65
Thursday April 14, 2011	\$20.90	\$37,376.41
Friday April 15, 2011	\$20.40	\$36,482.24
Saturday April 16, 2011	\$20.00	\$35,766.90
Sunday April 17, 2011	\$20.00	\$35,766.90
Monday April 18, 2011	\$20.00	\$35,766.90
Tuesday April 19, 2011	\$20.00	\$35,766.90
Wednesday April 20, 2011	\$20.00	\$35,766.90
Thursday April 21, 2011	\$20.00	\$35,766.90
Friday April 22, 2011	\$20.00	\$35,766.90
Saturday April 23, 2011	\$20.00	\$35,766.90

**CONFIDENTIAL – SUBJECT TO UTAH PUBLIC SERVICE COMMISSION RULE 746-100-16**

Sunday April 24, 2011	\$20.00	\$35,766.90
Monday April 25, 2011	\$20.00	\$35,766.90
Tuesday April 26, 2011	\$20.00	\$35,766.90
Wednesday April 27, 2011	\$20.00	\$35,766.90
Thursday April 28, 2011	\$20.00	\$35,766.90
Friday April 29, 2011	\$20.00	\$35,766.90
Saturday April 30, 2011	\$20.00	\$35,766.90
Sunday May 1, 2011	\$20.00	\$35,766.90
Monday May 2, 2011	\$20.00	\$35,766.90
Tuesday May 3, 2011	\$20.00	\$35,766.90
Wednesday May 4, 2011	\$20.00	\$35,766.90
Thursday May 5, 2011	\$20.00	\$35,766.90
Friday May 6, 2011	\$20.00	\$35,766.90
Saturday May 7, 2011	\$20.00	\$35,766.90
Sunday May 8, 2011	\$20.00	\$35,766.90
Monday May 9, 2011	\$20.00	\$35,766.90
Tuesday May 10, 2011	\$20.00	\$35,766.90
Wednesday May 11, 2011	\$20.00	\$35,766.90
Thursday May 12, 2011	\$20.00	\$35,766.90
Friday May 13, 2011	\$20.00	\$35,766.90
Saturday May 14, 2011	\$20.00	\$35,766.90
Sunday May 15, 2011	\$20.00	\$35,766.90
Monday May 16, 2011	\$20.00	\$35,766.90
Tuesday May 17, 2011	\$20.00	\$35,766.90
Wednesday May 18, 2011	\$20.00	\$35,766.90
Thursday May 19, 2011	\$20.00	\$35,766.90
Friday May 20, 2011	\$20.00	\$35,766.90
Saturday May 21, 2011	\$20.00	\$35,766.90
Sunday May 22, 2011	\$20.00	\$35,766.90
Monday May 23, 2011	\$20.00	\$35,766.90
Tuesday May 24, 2011	\$20.00	\$35,766.90
Wednesday May 25, 2011	\$20.00	\$35,766.90
Thursday May 26, 2011	\$20.00	\$35,766.90
Friday May 27, 2011	\$20.00	\$35,766.90
Saturday May 28, 2011	\$20.00	\$35,766.90
Sunday May 29, 2011	\$20.00	\$35,766.90
Monday May 30, 2011	\$20.00	\$35,766.90
Tuesday May 31, 2011	\$20.00	\$35,766.90
Total Delay Damages		\$2,066,164.63

**EXHIBIT D**

**START-UP TESTING**

Required factory testing includes such checks and tests necessary to determine that the equipment systems and subsystems have been properly manufactured and installed, function properly, and are in a condition to permit safe and efficient start-up of the facility, which may include but are not limited to:

1. Test of mechanical and electrical equipment;
2. Calibration of all monitoring instruments;
3. Point to point continuity tests;
4. Individual equipment and operational test (AC power, inverters, trackers, wire management etc.);
5. Tests required by manufacturer of equipment;
6. Substation and MV switchgear tests;
7. Utility Tests.

Required Start-up tests are those checks and tests necessary to determine that all features and equipment, systems and subsystems have been properly installed and adjusted, function properly and are capable of operating simultaneously in such condition that the facility is capable of continuous delivery into Pacific Corps electrical system, which may include but are not limited to:

1. System operation tests;
2. Excitation and voltage regulation tests;
3. Completion of any state and federal environmental testing requirements
4. Performance testing;
5. SCADA testing
6. Equipment Verification of communication;
7. Software function verification.

In addition, A Photovoltaic installation Checklist is a required document to be signed off by Manufacturer or Subcontract Category Commissioning Personnel as part of the Commissioning and start-up testing.

EXHIBIT E

EXAMPLE CALCULATION OF PACIFICORP'S COST TO COVER

Period in Question April 1, 2011 through December 31, 2011  
 Contract Price \$66.00 /MWh (illustrative only)

Firm Market Price Index Per Agreement definition

DATE	A	B	C	D	E
	Firm On Peak	Firm Off Peak	Sun & NERC 24 HOUR	Weighted Average Firm Mkt Price C or [ (16 X A + 8 X B) / 24 ]	PacifiCorp's Cost to Cover Max [ 0.0, (D – 66.00) ] (\$/MWh)
Friday April 1, 2011	\$52.82	\$34.86		\$46.83	\$0.00
Saturday April 2, 2011	\$50.23	\$32.77		\$44.41	\$0.00
Sunday April 3, 2011			\$38.32	\$38.32	\$0.00
Monday April 4, 2011	\$52.82	\$34.86		\$46.83	\$0.00
Tuesday April 5, 2011	\$52.82	\$34.86		\$46.83	\$0.00
Wednesday April 6, 2011	\$52.82	\$34.86		\$46.83	\$0.00
Thursday April 7, 2011	\$52.82	\$34.86		\$46.83	\$0.00
Friday April 8, 2011	\$52.82	\$34.86		\$46.83	\$0.00
Saturday April 9, 2011	\$50.23	\$32.77		\$44.41	\$0.00
Sunday April 10, 2011			\$38.32	\$38.32	\$0.00
Monday April 11, 2011	\$52.82	\$34.86		\$46.83	\$0.00
Tuesday April 12, 2011	\$52.82	\$34.86		\$46.83	\$0.00

Tuesday December 20, 2011	\$56.21	\$42.15		\$51.52	\$0.00
Wednesday December 21, 2011	\$56.21	\$42.15		\$51.52	\$0.00
Thursday December 22, 2011	\$56.21	\$42.15		\$51.52	\$0.00
Friday December 23, 2011	\$56.21	\$42.15		\$51.52	\$0.00
Saturday December 24, 2011	\$56.49	\$41.74		\$51.57	\$0.00
Sunday December 25, 2011			\$44.99	\$44.99	\$0.00
Monday December 26, 2011			\$44.99	\$44.99	\$0.00
Tuesday December 27, 2011	\$56.21	\$42.15		\$51.52	\$0.00
Wednesday December 28, 2011	\$56.21	\$42.15		\$51.52	\$0.00
Thursday December 29, 2011	\$67.45	\$63.23		\$66.04	\$0.04
Friday December 30, 2011	\$67.45	\$63.23		\$66.04	\$0.04
Saturday December 31, 2011	\$67.79	\$62.62		\$66.06	\$0.06

Cost to Cover for  
2011 \$ 0

- \* The Cost to Cover for each Calendar Year is the average of the daily Cost to Cover calculations shown above.
- \* Firm On-peak and Firm Off-peak prices in this example are illustrative only.
- \* The Contract Price used in the example above is illustrative only. Actual Contract Prices are in **Exhibit 5.1.2**.

**EXHIBIT F**

**SAMPLE REPORT FROM FIRM MARKET PRICE INDEX**

(see attached)



CONFIDENTIAL – SUBJECT TO UTAH PUBLIC SERVICE COMMISSION RULE 746-100-16

Begin Date	End Date	High	Low	Avg	Chg	Vol (MWH)	# Deals
Jul 3, 2009	Jul 3, 2009	35.00	32.50	33.29	-2.95	22,800	1
Jul 6, 2009	Jul 6, 2009	35.00	30.25	31.30	-1.99	18,400	1
Jul 7, 2009	Jul 7, 2009	35.50	30.00	31.42	1.12	19,600	1
Jul 8, 2009	Jul 8, 2009	35.00	32.00	33.32	1.90	23,200	1
Jul 9, 2009	Jul 9, 2009	32.50	31.00	32.00	-1.32	32,400	1
Jul 10, 2009	Jul 11, 2009	32.75	31.00	32.21	.21	64,800	1
Jul 13, 2009	Jul 13, 2009	38.50	36.00	36.49	4.28	35,600	1
Jul 14, 2009	Jul 14, 2009	42.75	38.00	40.63	4.14	27,600	1
Jul 15, 2009	Jul 15, 2009	45.00	44.00	44.51	3.88	27,600	1
Jul 16, 2009	Jul 16, 2009	45.75	44.00	45.11	.60	25,600	1
Jul 17, 2009	Jul 18, 2009	42.50	39.50	41.22	-3.89	68,000	1
Jul 20, 2009	Jul 20, 2009	45.75	42.50	43.65	2.43	22,400	1
Jul 21, 2009	Jul 21, 2009	50.00	46.50	48.13	4.48	14,000	1
Jul 22, 2009	Jul 22, 2009	49.25	44.00	47.39	-1.74	26,400	1
Jul 23, 2009	Jul 23, 2009	46.25	43.50	45.05	-2.34	22,800	1
Jul 24, 2009	Jul 25, 2009	45.65	42.75	43.57	-1.48	40,800	1
Jul 27, 2009	Jul 27, 2009	46.50	42.50	43.60	.03	15,600	1
Jul 28, 2009	Jul 28, 2009	47.50	45.25	45.97	2.37	17,200	1
Jul 29, 2009	Jul 30, 2009	43.00	41.75	42.45	-3.52	36,000	1
Jul 31, 2009	Jul 31, 2009	39.25	38.00	38.92	-3.53	16,000	1
Aug 1, 2009	Aug 1, 2009	37.00	34.00	36.26	-2.66	19,600	1
Aug 3, 2009	Aug 3, 2009	38.25	36.50	37.44	1.18	19,200	1
Aug 4, 2009	Aug 4, 2009	40.00	37.25	39.38	1.94	13,200	1
Aug 5, 2009	Aug 5, 2009	39.00	38.00	38.74	-.64	14,800	1
Aug 6, 2009	Aug 6, 2009	37.00	36.50	37.52	-1.22	18,400	1
Aug 7, 2009	Aug 8, 2009	37.00	35.25	36.10	-1.42	44,000	1
Aug 10, 2009	Aug 10, 2009	40.00	36.75	38.53	2.43	20,000	1
Aug 11, 2009	Aug 11, 2009	43.00	36.25	41.83	3.30	20,000	1
Aug 12, 2009	Aug 12, 2009	40.25	36.50	38.99	-2.84	18,800	1
Aug 13, 2009	Aug 13, 2009	37.25	32.50	35.35	-3.64	16,000	1
Aug 14, 2009	Aug 15, 2009	34.25	31.00	32.45	-2.90	44,000	1
Aug 17, 2009	Aug 17, 2009	37.25	31.25	34.15	1.70	27,200	1
Aug 18, 2009	Aug 18, 2009	33.25	29.00	31.61	-2.54	15,200	1
Jul 3, 2009	Jul 4, 2009	23.50	21.50	22.51	.24	28,000	1
Jul 5, 2009	Jul 6, 2009	23.00	22.00	22.79	.28	32,000	1
Jul 7, 2009	Jul 7, 2009	19.00	17.25	17.85	-4.94	8,400	1
Jul 8, 2009	Jul 8, 2009	18.25	17.25	17.89	.04	8,200	1

**EXHIBIT G**

**APPROVED LICENSED PROFESSIONAL ENGINEERS**

- 1) Black & Veatch  
6601 College Boulevard  
Overland Park, KS 66211
- 2) BEW Engineering, Inc.  
2303 Camino Ramon, Suite 220  
San Ramon, CA 94583
- 3) Electric Power Systems  
3305 Arctic Blvd, Suite 201  
Anchorage, AL 99503
- 4) Power Engineers  
3490 Glenbrook Drive  
PO Box 1066  
Hailey, ID 83333
- 5) ABB Inc. – System Consulting  
940 Main Campus Drive, Suite 300  
Raleigh, North Carolina 27606
- 6) Pterra Consulting  
4 Automation Lane, Suite 250  
Albany, NY 12205
- 7) SAIC  
Denver office

**EXHIBIT 2.7**

**PACIFICORP'S INITIAL DESIGNATED REPRESENTATIVES**

Authorized Representatives:

PacifiCorp: Senior Vice President—Commercial & Trading  
PacifiCorp Energy  
825 NE Multnomah St., Suite 600  
Portland, OR 97232-2315  
Fax 503-813-6271

With a copy to: Manager , Marketing and Trading Contracts  
PacifiCorp Commercial and Trading  
825 NE Multnomah St., Suite 600  
Portland, OR 97232-2315  
Fax 503-813-6271

EXHIBIT 3.2.3

REQUIRED FACILITY DOCUMENTS

Qualifying Facility Number from FERC: Will be self-certified

**1. Obtained Required Facility Documents:**

Permits: Conditional Use Permit (“CUP”), Iron County #00605997

Land Rights: All land secured – see Exhibit 3.2.6.

**2. To Be Obtained (Prior to Commercial Operation) Required Facility Documents:**

Licenses, Permits and Authorizations:

Qualifying Facility Certification from FERC – Will be self-certified

Access road easement – None Needed.

Electrical Permit – Final Construction drawing documents to be submitted to Iron County.

Land Use Permit – Complete CUP with Iron County #00605997.

Environmental Permit – Included in CUP.

Building Permit – Final Construction drawing documents to be submitted to Iron County.

Interconnection approval – PacifiCorp Large Generator Interconnection Agreement (“LGIA”) Queue [REDACTED].

Utility easement – None needed.

Construction and Operations and Maintenance:

Contract for the Sale of Power Generation Equipment and Related Services between Engineering, Procurement and Construction Firm and Seller

Generator Interconnection Agreement – Interconnection Agreement with PacifiCorp to be obtained.

Retail Electric Service Agreement – Service request will be submitted upon execution of PPA. UAMPS/RMP

Proof of Insurance – Certificates of Insurance to be provided prior to activity, construction or operations.

Construction Agreements:

Balance of Plant/Construction Services Agreement – Contracts to be obtained when required.

Operations and Maintenance Agreements:

Warranty, Service and Maintenance Agreement – Warranties and Agreements shall be obtained prior to Facility operations.

**SUCH LIST MAY BE UPDATED PURSUANT TO SECTION 3.2.3**

**EXHIBIT 3.2.6**

**LEASES**

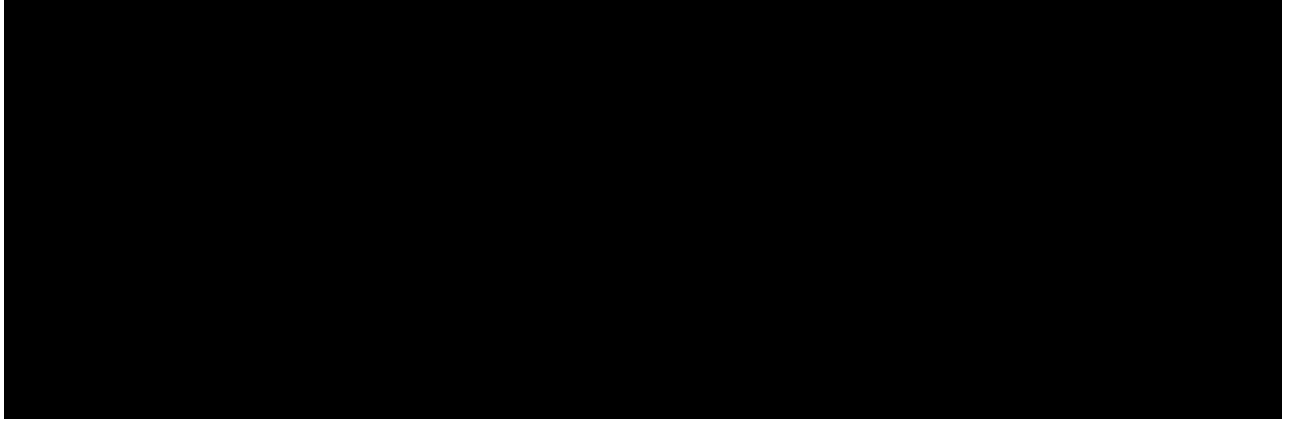

**EXHIBIT 5.1**  
**CONTRACT PRICE**

Prices shown in \$ per MWh.

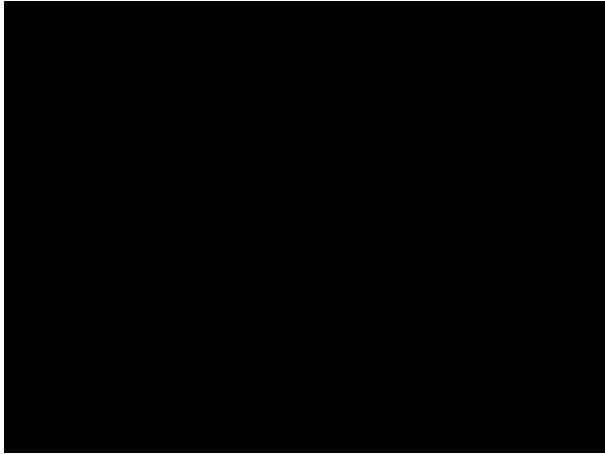

**EXHIBIT 5.1.1**

**SCALING FACTOR**

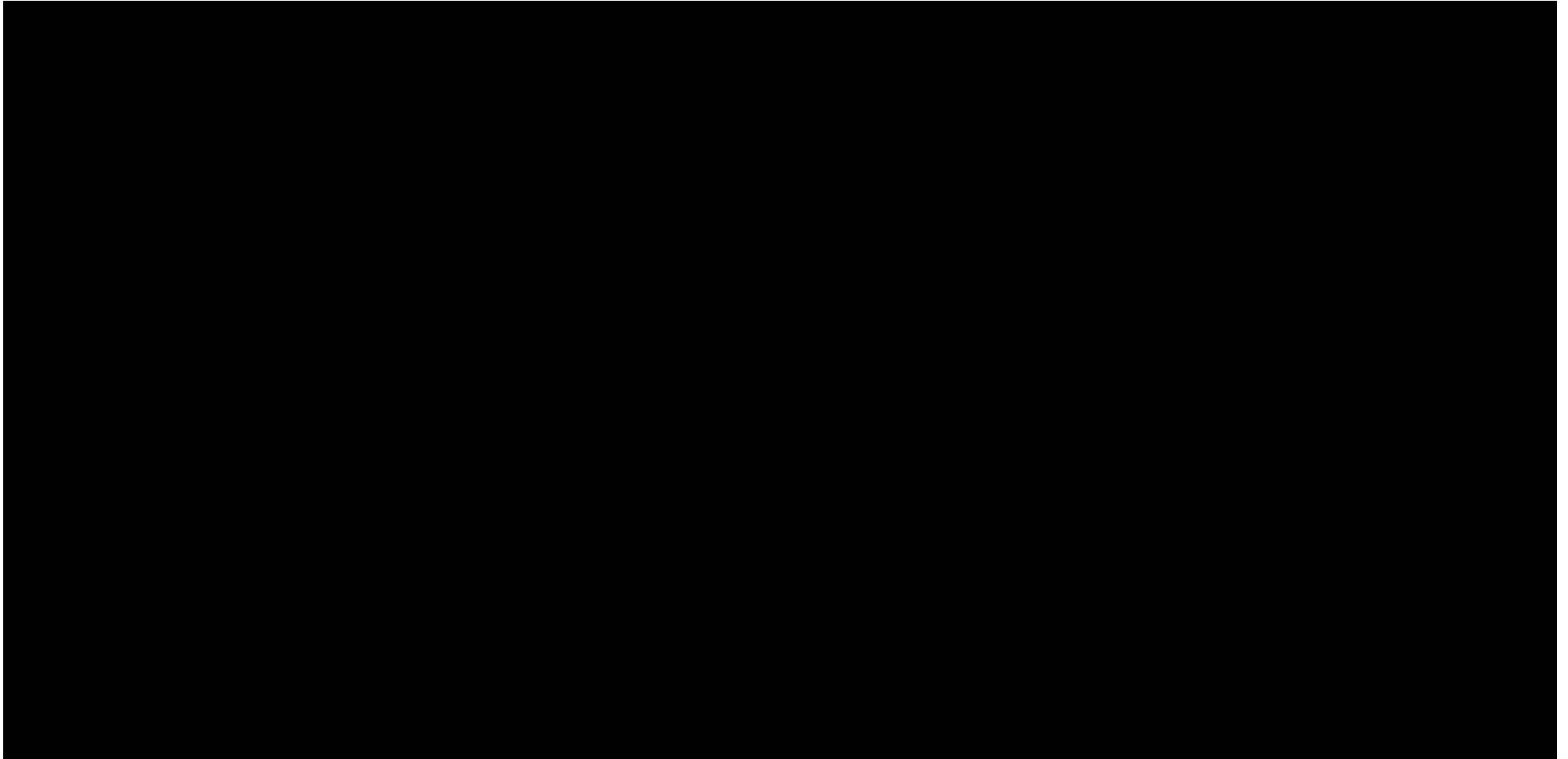



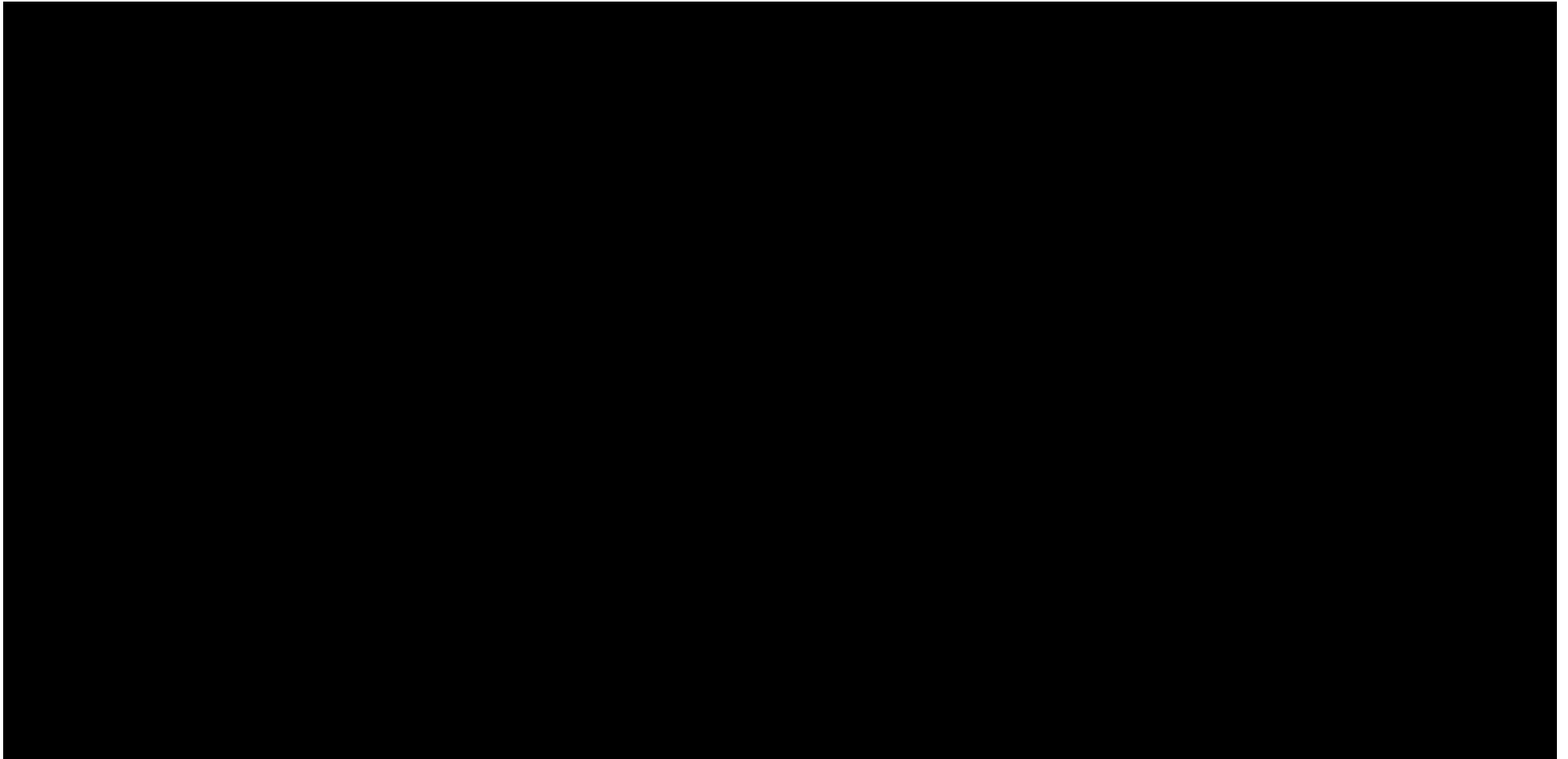

EXHIBIT 6.1

Description of Seller’s Facility

Seller’s Facility consists of Approximately [redacted] panels rated between [redacted] manufactured by [redacted] inverters manufactured by [redacted], and a [redacted]. More specifically, the Facility includes:

A. Manufacturer’s Nameplate Data: [redacted]

Solar Panels

Manufacturer: [redacted]  
[redacted]  
[redacted]  
[redacted]  
[redacted]

Inverters

[redacted]  
[redacted]  
[redacted]  
[redacted]  
[redacted]  
[redacted]

Mounting

[redacted]  
[redacted]  
[redacted]  
[redacted]  
[redacted]  
[redacted]  
[redacted]

[REDACTED]

[REDACTED]

[REDACTED]

[REDACTED]

[REDACTED]

[REDACTED]

[REDACTED]

[REDACTED]

[REDACTED]

---

Project Description

Location

Location of the Facility: Parowan, Utah in the \_\_\_quarter of the \_\_\_ quarter of S\_\_\_, T\_\_\_ S,  
R\_\_\_W,

The site is an approximately a 650 acre site located near the Town of Parowan, Utah.

[REDACTED]

[REDACTED]

[REDACTED]

[REDACTED]

[REDACTED]

[REDACTED]

[REDACTED]

[REDACTED]

[REDACTED]

[REDACTED]

**EXHIBIT 6.1 — Attachments**

1. \_\_\_\_\_ Site Map
2. Distance Between Solar Panels of Adjacent Qualifying Facilities [\*\*Note to Drafter – may not be applicable to the extent there may not be a requirement for spacing of solar generation facilities.\*\*]

See Substation and owners substation location, below:

Substation and Owner substation locations.

### Rocky Mountain Power Parowan Valley Substation & Utah Red Hills Project Substation Area

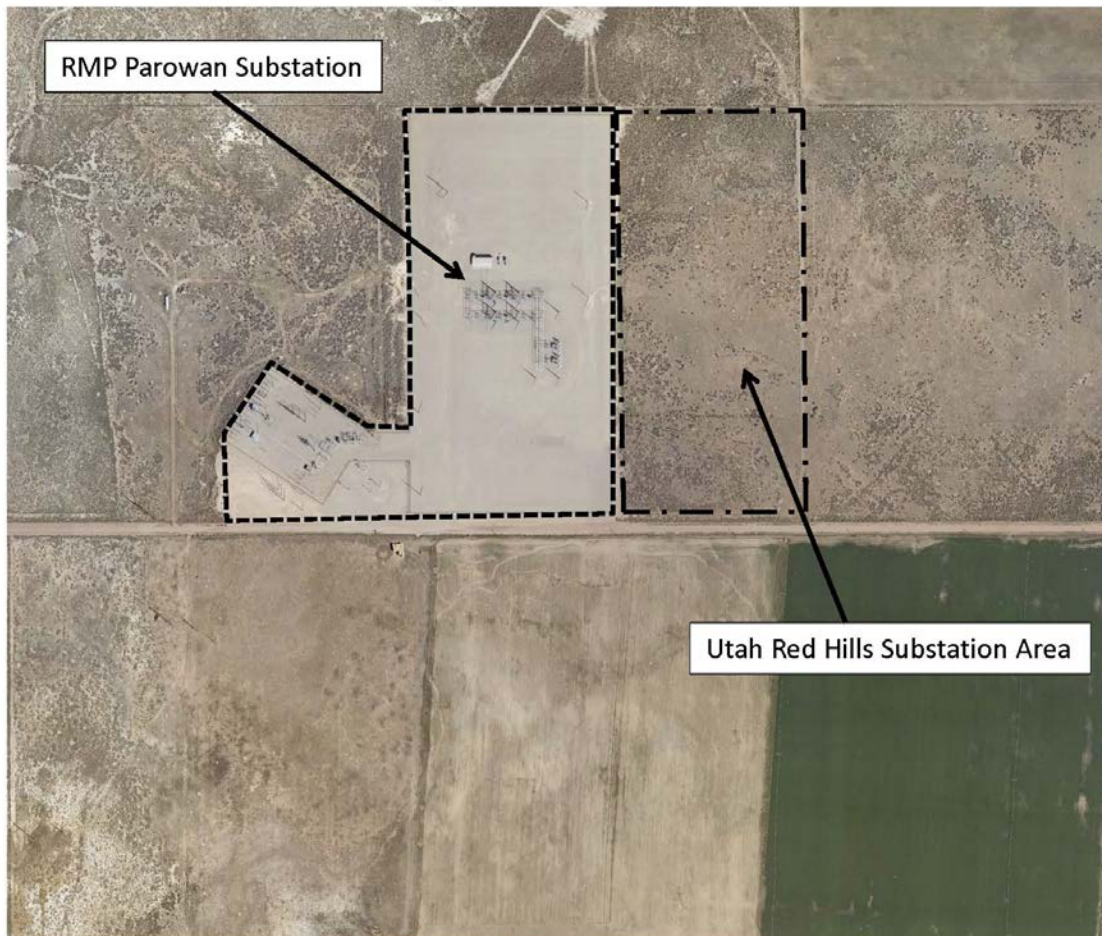
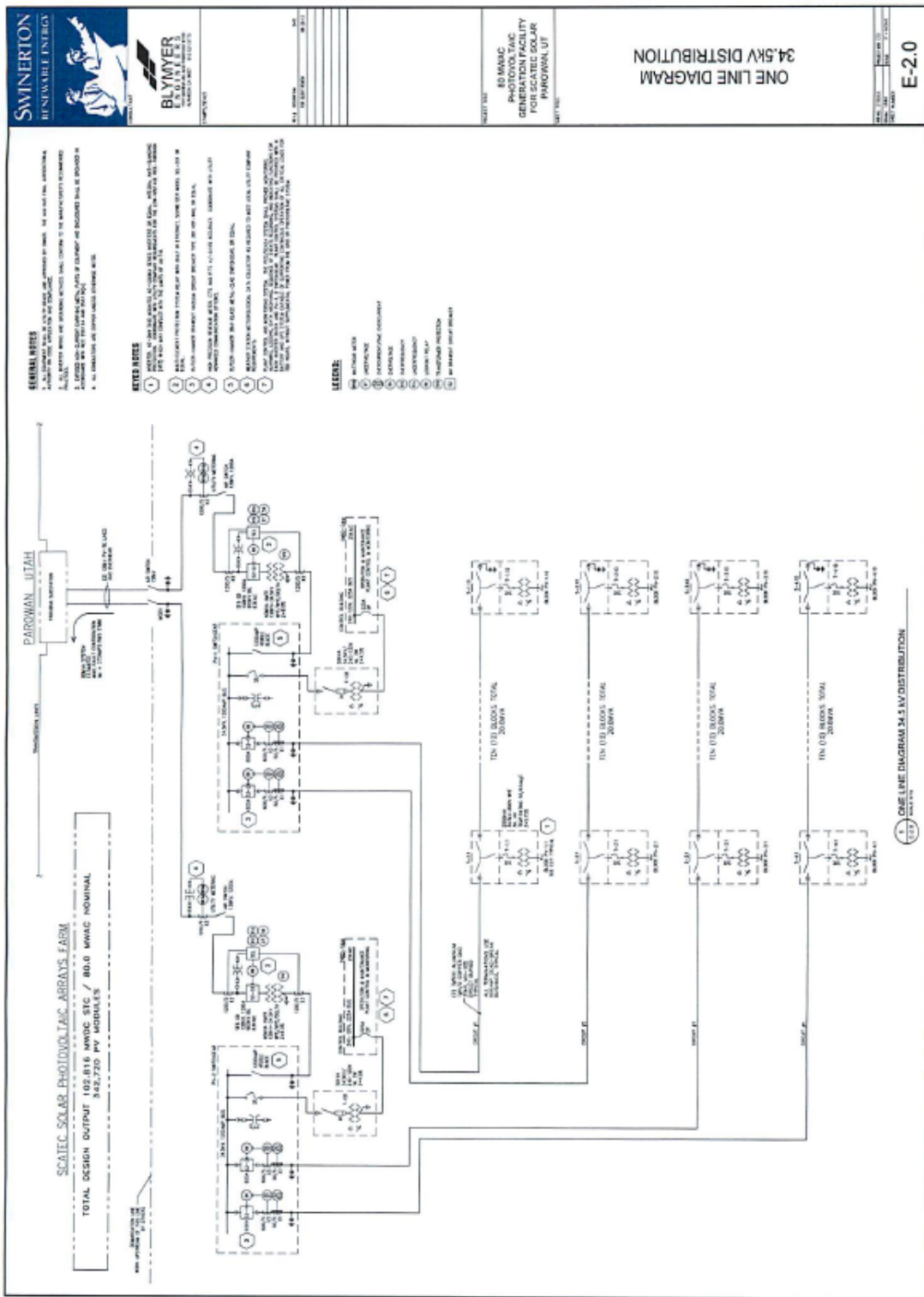

**Exhibit 6.1.**

**Attachment 1**

**Substation Metering – One-Line Diagram**

**(See Attached)**



**SWINERTON**  
 RENEWABLE ENERGY

**BLUMAYER**  
 ELECTRICAL ENGINEERS

**34.5 KV DISTRIBUTION**

**ONE LINE DIAGRAM 34.5 KV DISTRIBUTION**

**E-2.0**

PROJECT NO. 17-00000000  
 SHEET NO. E-2.0  
 DATE 11/15/17

80 MWDC  
 PHOTOVOLTAIC  
 GENERATION FACILITY  
 FOR SCATEC SOLAR  
 PAROWAN, UT





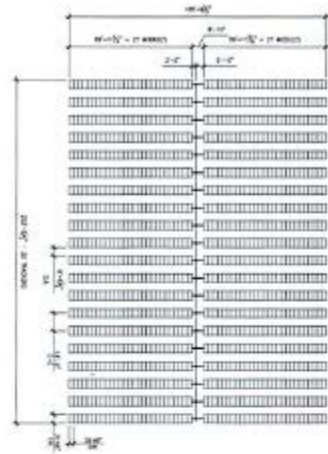

TYPE 1 SUB-ARRAY DETAIL

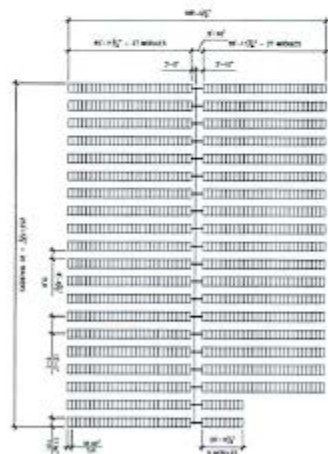

TYPE 2 SUB-ARRAY DETAIL

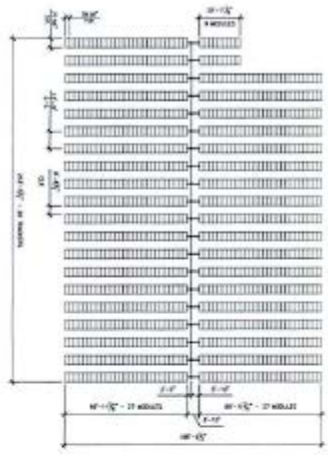

TYPE 3 SUB-ARRAY DETAIL

		80 WIND PHOTOVOLTAIC DEMONSTRATION FACILITY FORT MONTEZUMA PARIAH, UT	PHOTOVOLTAIC SUB-ARRAY TYPES 1-3	G-101
--	--	---	-------------------------------------	-------

**Exhibit 6.1**

**Siteplan**

**(See Attached)**

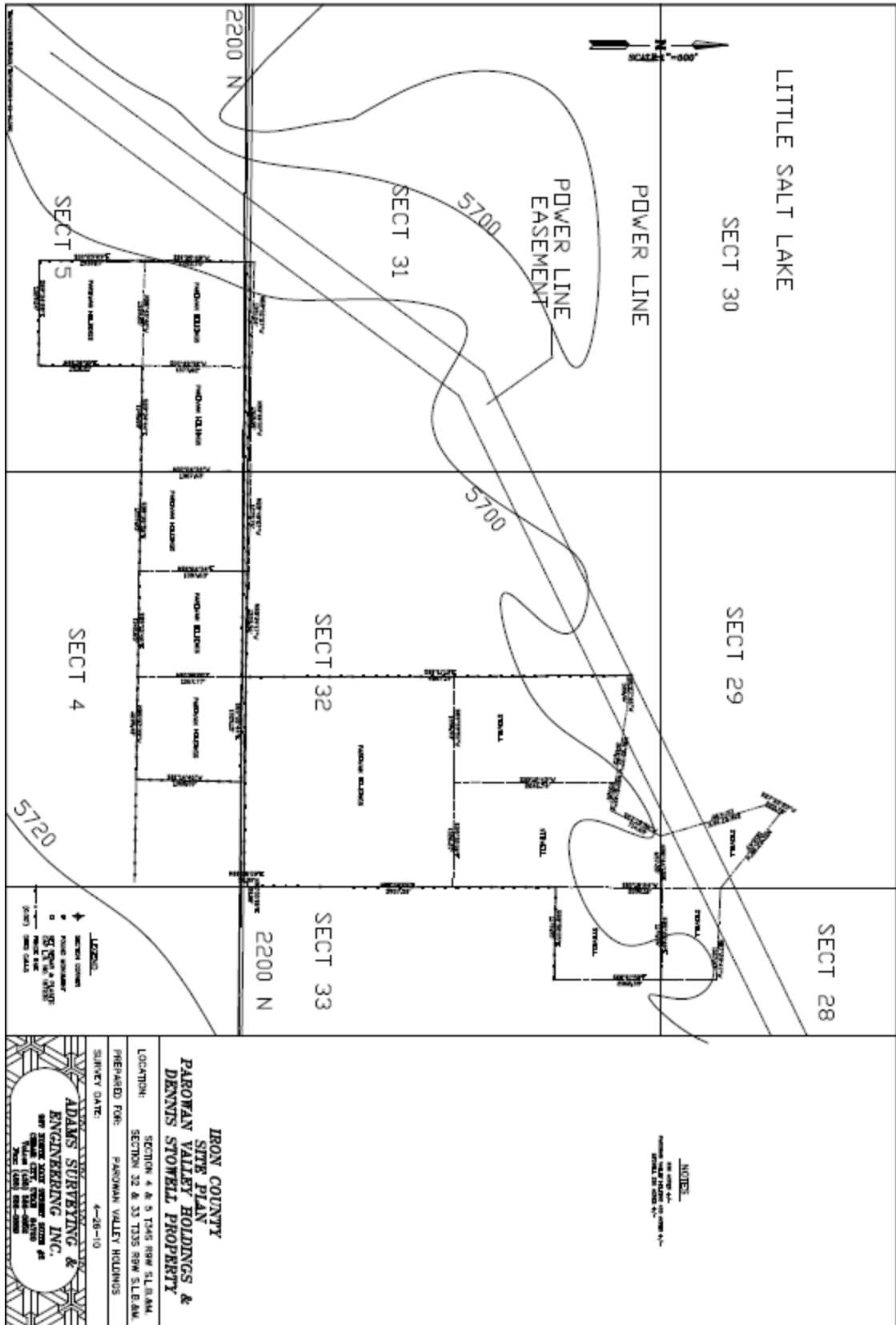

**EXHIBIT 6.12.2**

**EXAMPLE CALCULATION OF LIQUIDATED DAMAGES  
FOR AN OUTPUT SHORTFALL**

Damages shall be calculated as the product of the Output Shortfall and PacifiCorp's Cost to Cover for each Contract Year in which an Output Shortfall occurs.

EXHIBIT 8.2.1

FORM OF GUARANTY — CREDIT SUPPORT SECURITY

THIS GUARANTY AGREEMENT (this “Guaranty”), dated as of \_\_\_\_\_, 20\_\_, is issued and delivered by \_\_\_\_\_, a \_\_\_\_\_ corporation (the “Guarantor”), for the account of \_\_\_\_\_, a \_\_\_\_\_ limited liability company (the “Obligor”), and for the benefit of PacifiCorp, an Oregon corporation (the “Beneficiary”).

Background Statement

WHEREAS, the Beneficiary and Obligor entered into that certain Power Purchase Agreement, dated as of \_\_\_\_\_, 20\_\_ (the “Agreement”); and

WHEREAS, Guarantor delivers to the Beneficiary this Guaranty as an inducement to Beneficiary to enter into the Agreement.

Agreement

NOW, THEREFORE, in consideration of the foregoing and for good and valuable consideration, the Guarantor hereby agrees as follows:

1. Guaranty; Limitation of Liability. Subject to any rights, setoffs, counterclaims and any other defenses of Obligor under the Agreement that the Guarantor expressly reserves to itself under this Guaranty (except as set forth below), the Guarantor absolutely and unconditionally guarantees the timely payment of the Obligor’s payment obligations under the Agreement (the “Guaranteed Obligations”); provided, however, that the Guarantor’s aggregate liability hereunder shall not exceed Expenses as defined in Section 12, plus (a) \_\_\_\_\_ U.S. Dollars (U.S. \$ \_\_\_\_\_) for the period from the date that is ten (10) days after the effective date of the Agreement, through but not including the date that is three (3) months after the effective date of the Agreement, (b) \_\_\_\_\_ (U.S.\$ \_\_\_\_\_) for the period from the date that is three (3) months after the effective date of the Agreement through but not including the Commercial Operation Date (as defined in the Agreement), and (c) \_\_\_\_\_ U.S. Dollars (U.S. \$ \_\_\_\_\_) for the period from the Commercial Operation Date (as defined in the Agreement) through the Expiration Date.

2. Subject to the other terms of this Guaranty, the liability of the Guarantor under this Guaranty is limited to Expenses as defined in Section 12, and payments expressly required to be made by Obligor under the Agreement, and except as specifically provided therein, the Guarantor shall not be liable for or required to pay any consequential or indirect loss (including but not limited to loss of profits), exemplary damages, punitive damages, special damages, or any other damages or costs.

3. Effect of Amendments. The Guarantor agrees that the Beneficiary and the Obligor may modify, amend and supplement the Agreement and that the Beneficiary may delay or extend the date on which any payment must be made pursuant to the Agreement or delay or extend the date on which any act must be performed by the Obligor thereunder, all without

**CONFIDENTIAL – SUBJECT TO UTAH PUBLIC SERVICE COMMISSION RULE 746-100-16**

notice to or further assent by the Guarantor, who shall remain bound by this Guaranty, notwithstanding any such act by the Beneficiary.

4. Waiver of Rights. The Guarantor expressly waives (i) protest, (ii) notice of acceptance of this Guaranty by the Beneficiary, (iii) demand for payment of any of the Guaranteed Obligations; (iv) any right to assert against Beneficiary any defense (legal or equitable), counter-claim, set-off, cross-claim or other claim that Guarantor may now or at any time hereafter have (a) against Obligor or (b) acquired from any other party, not affiliated with Guarantor, to which Beneficiary may be liable; and (v) any defense arising by reason of any claim or defense based upon an election of remedies by Beneficiary which in any manner impairs, affects, reduces, releases, destroys or extinguishes Guarantor's subrogation rights, rights to proceed against Obligor for reimbursement, or any other rights of the Guarantor to proceed against Obligor or against any other person, property or security.

5. Reservation of Defenses. Without limiting the Guarantor's own defenses and rights hereunder, the Guarantor reserves to itself all rights, setoffs, counterclaims and other defenses that the Obligor may have to payment of all or any portion of the Guaranteed Obligations except defenses arising from the bankruptcy, insolvency, dissolution or liquidation of the Obligor and other defenses expressly waived in this Guaranty.

6. Settlements Conditional. If any monies paid to the Beneficiary in reduction of the indebtedness of the Obligor under the Agreement have to be repaid by the Beneficiary by virtue of any provision or enactment relating to bankruptcy, insolvency or liquidation for the time being in force, the liability of the Guarantor under this Guaranty shall be computed as if such monies had never been paid to the Beneficiary.

7. Subrogation. The Guarantor shall be subrogated to all rights of the Beneficiary against the Obligor in respect of any amounts paid by the Guarantor pursuant to this Guaranty; provided, however, that the Guarantor hereby postpones all rights of subrogation, reimbursement, indemnity and recourse (including, without limitation, any statutory rights of subrogation under Section 509 of the Bankruptcy Code, 11 U.S.C. § 509, or otherwise) until such time as all amounts due under the Agreement are paid in full and Section 6 hereof fully, finally, and indefeasibly performed. If (i) the Guarantor shall perform and shall make payment to the Beneficiary of all or any part of the Guaranteed Obligations and (ii) all the then outstanding obligations under the Agreement have been paid in full, Beneficiary shall, at the Guarantor's request, execute and deliver to the Guarantor documents to evidence the transfer by subrogation to the Guarantor of any interest in the obligations under the Agreement resulting from such payment by the Guarantor.

8. Notice. The Beneficiary will provide written notice to the Guarantor if the Obligor defaults under the Agreement.

9. Primary Liability of the Guarantor. The Guarantor agrees that the Beneficiary may enforce this Guaranty without the necessity at any time of resorting to or exhausting any other security or collateral, howsoever arising. This is a continuing Guaranty of payment and not merely of collection.

**CONFIDENTIAL – SUBJECT TO UTAH PUBLIC SERVICE COMMISSION RULE 746-100-16**

10. Term of Guaranty. This Guaranty shall remain in full force and effect until the earlier of (i) such time as all the Guaranteed Obligations have been finally and indefeasibly discharged in full, and (ii) \_\_\_\_\_ (the “Expiration Date”); provided however, the Guarantor will remain liable hereunder for Guaranteed Obligations that were outstanding prior to the Expiration Date.

11. Governing Law. This Guaranty shall be governed by and construed in accordance with the internal laws of the State of Utah.

12. Expenses. The Guarantor agrees to pay all reasonable out-of-pocket expenses (including the reasonable fees and expenses of the Beneficiary’s counsel) relating to the enforcement of the Beneficiary’s rights hereunder in the event the Guarantor disputes its obligations under this Guaranty and it is finally determined (whether through settlement, arbitration or adjudication, including the exhaustion of all permitted appeals), that the Beneficiary is entitled to receive payment of a portion of or all of such disputed amounts; provided, however, that the Guarantor’s aggregate liability for such expenses shall not exceed two hundred fifty thousand U. S. Dollars (U.S. \$250,000) (“Expenses”).

13. Waiver of Jury Trial. The Guarantor and the Beneficiary, through acceptance of this Guaranty, waive all rights to trial by jury in any action, proceeding or counterclaim arising or relating to this Guaranty.

14. Entire Agreement; Amendments. This Guaranty integrates all of the terms and conditions mentioned herein or incidental hereto and supersedes all oral negotiations and prior writings in respect to the subject matter hereof. This Guaranty may only be amended or modified by an instrument in writing signed by each of the Guarantor and the Beneficiary.

15. Headings. The headings of the various Sections of this Guaranty are for convenience of reference only and shall not modify, define or limit any of the terms or provisions hereof.

16. No Third-Party Beneficiary. This Guaranty is given by the Guarantor solely for the benefit of the Beneficiary, and is not to be relied upon by any other person or entity.

17. Assignment. Neither the Guarantor nor the Beneficiary may assign its rights or obligations under this Guaranty without the prior written consent of the other, which consent may not be unreasonably withheld or delayed, except that:

(i) the Guarantor may make such an assignment without such consent if the assignee meets the Credit Requirements as defined in the Agreement, provided that the Guarantor’s obligations hereunder must be expressly assumed in writing, in a form reasonably acceptable to the Beneficiary; provided further that such assumption shall be deemed to release the Guarantor from all of its obligations under this Guaranty automatically and without further action by the Guarantor or the Beneficiary, and

(ii) the Beneficiary may, upon thirty (30) days’ prior written notice, make such an assignment without such consent if in conjunction with any assignment of the



**CONFIDENTIAL – SUBJECT TO UTAH PUBLIC SERVICE COMMISSION RULE 746-100-16**

Agreement by the Beneficiary permitted under the Agreement. Any purported assignment in violation of this Section 17 shall be void and without effect.

18. Notices. Any communication, demand or notice to be given hereunder will be duly given when delivered in writing or sent by facsimile to the Guarantor or to the Beneficiary, as applicable, at its address as indicated below:

If to the Guarantor, at:

With a copy to:

If to the Beneficiary, at:

PacifiCorp  
825 NE Multnomah Street, Suite 700  
Portland, OR 97232  
Attn: Credit Manager  
Facsimile No.: 503-813-5609

With a copy to:

PacifiCorp Office of the General Counsel  
825 NE Multnomah Street, Suite 700  
Portland, OR 97232  
Attn: Jeff Erb and Jeremy Weinstein  
Facsimile No.: 503-813-6260 and 925-943-3105

or such other address as the Guarantor or the Beneficiary shall from time to time specify. Notice shall be deemed given (a) when received, as evidenced by signed receipt, if sent by hand delivery, overnight courier or registered mail or (b) when received, as evidenced by transmission confirmation report, if sent by facsimile and received on or before 4 pm local time of recipient, or (c) the next business day, as evidenced by transmission confirmation report, if sent by facsimile and received after 4 pm local time of recipient.

19. Jury Trial Waiver. TO THE FULLEST EXTENT PERMITTED BY LAW, EACH OF THE PARTIES HERETO WAIVES ANY RIGHT IT MAY HAVE TO A TRIAL BY JURY IN RESPECT OF LITIGATION DIRECTLY OR INDIRECTLY ARISING OUT OF, UNDER OR IN CONNECTION WITH THIS AGREEMENT. EACH PARTY FURTHER WAIVES ANY RIGHT TO CONSOLIDATE ANY ACTION IN WHICH A JURY TRIAL HAS BEEN WAIVED WITH ANY OTHER ACTION IN WHICH A JURY TRIAL CANNOT BE OR HAS NOT BEEN WAIVED.

IN WITNESS WHEREOF, the Guarantor has executed this Guaranty as of the day and year first above written.

By: \_\_\_\_\_  
Name:  
Title:

[REDACTED]

[REDACTED]

[REDACTED]

EXHIBIT 9.2

POINT OF DELIVERY/INTERCONNECTION FACILITIES

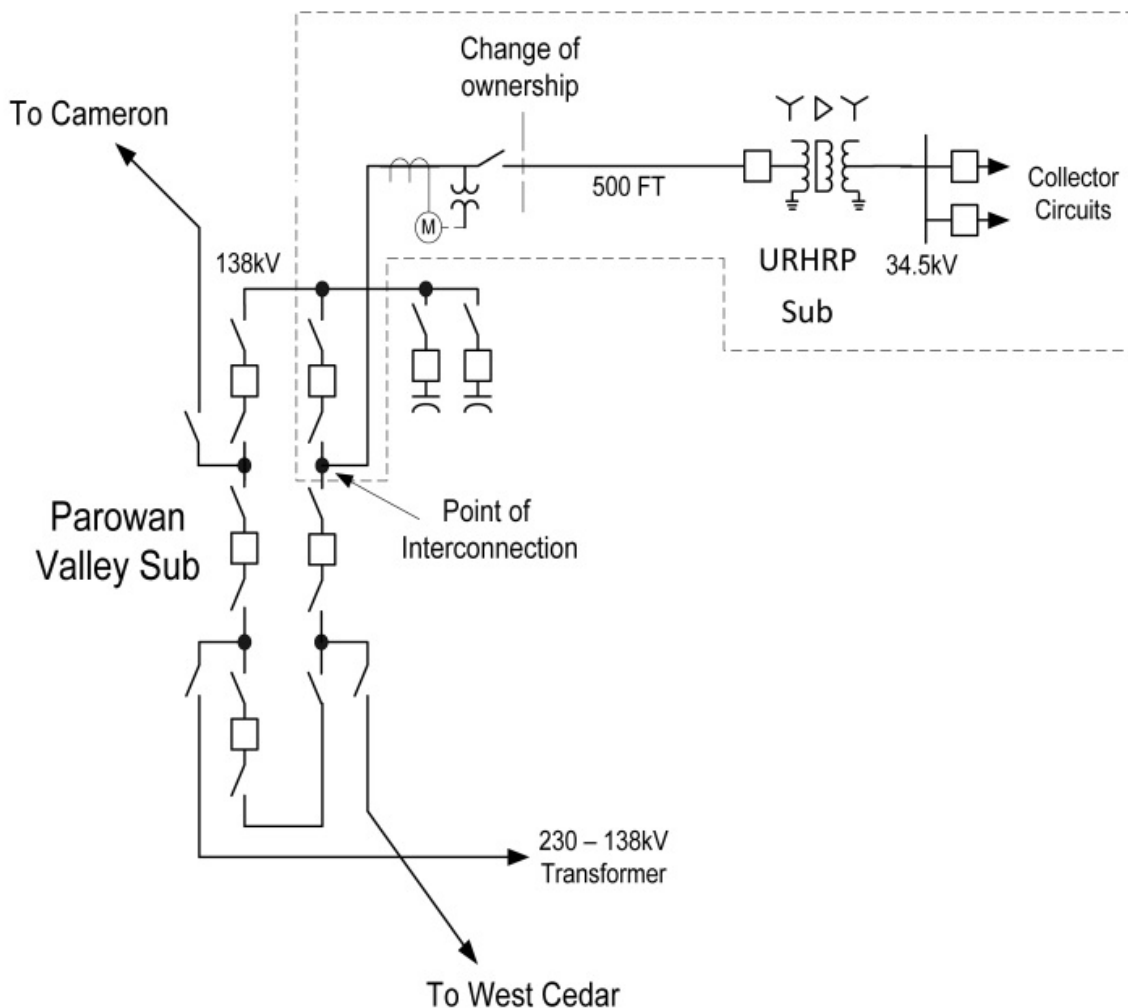

Instructions to Seller:

1. Include description of point of metering, and Point of Interconnection.

Point of Metering shall be within the Rocky Mountain Power Parowan Substation on the 138 kV rated line. New equipment within the Substation will be required and specified within an interconnection agreement between the Facility and the Transmission Provider, Rocky Mountain Power.

2. Include description of Point of Delivery.

Point of Delivery shall be within the Rocky Mountain Power Parowan Substation. Point of Delivery is the same as Point of Interconnection.

3. Provide interconnection single line drawing of Facility including any transmission facilities on Seller's side of the Point of Interconnection.

Provided as Exhibit 6.1, Attachment 1 is the Facility single line diagram. The Facility substation is adjacent to the Rocky Mountain Power Parowan Substation with an approximate 500 feet interconnection utility line between the Facility and Parowan Substation.

4. Provide transmission single line drawing of the transmission path from the Point of Interconnection to the Point of Delivery as the path is defined in the Transmission Agreement(s). Specify any changes of ownership along the transmission path. Specify the Transmission Agreement(s) governing each segment of Seller's transmission path, from the Point of Interconnection to the Point of Delivery.

Point of Interconnection is the same as Point of Delivery. There are no separate Transmission Agreements.

5. Describe Seller's arrangements for station service to the facility and show on one-line diagram how station service will be provided and metered.

The Facility electrical requirements will be satisfied via a 12kV line transecting the project area property. A service request with UAMPS will be filed once project construction starts.

6. Specify the maximum hourly rate (MW) at which Seller is permitted to deliver energy to the Point of Delivery and in compliance with Seller's transmission rights between the Point of Interconnection and the Point of Delivery ("Maximum Transmission Rate"):

[REDACTED]

**EXHIBIT B – Attachments**

1. Substation Metering One-Line Diagram (See Exhibit 6.1, Attachment 1)

**EXHIBIT 9.5**

**SELLER AUTHORIZATION TO RELEASE GENERATION DATA TO PACIFICORP**

October 9, 2013

Director, Transmission Services  
PacifiCorp  
825 NE Multnomah, Suite 1600  
Portland, OR 97232

To Whom it May Concern:

Utah Red Hills Renewable Park, LLC ("Seller") hereby voluntarily authorizes PacifiCorp's Transmission business unit to share Seller's interconnection information with Marketing Affiliate employees of PacifiCorp Energy, including but not limited to those in Commercial and Trading group. Seller acknowledges that PacifiCorp did not provide it any preferences, either operational or rate-related, in exchange for this voluntary consent.



Luigi Resta  
Managing Member

EXHIBIT 11.4

FORM OF MEMORANDUM OF POWER PURCHASE AGREEMENT

WHEN RECORDED, MAIL TO:

PACIFICORP  
825 NE Multnomah, Suite 2000  
Portland, Oregon 97232-2315  
Attn: Sr. Vice President, Commercial Trading and Manager of Contract Administration

MEMORANDUM OF POWER PURCHASE AGREEMENT

THIS MEMORANDUM OF POWER PURCHASE AGREEMENT ("Memorandum"), dated as of \_\_\_\_\_, 20\_\_, is made by and between Utah Red Hills Renewable Park, LLC a Delaware limited liability company ("Seller"), and PACIFICORP, an Oregon corporation acting in its merchant function capacity ("PacifiCorp"). Seller and PacifiCorp are sometimes hereinafter referred to collectively as the "Parties" and individually as a "Party".

RECITALS

A. Seller and PacifiCorp have entered into that certain Power Purchase Agreement on the \_\_\_ day of \_\_\_\_\_, 20\_\_ (the "Agreement"), pursuant to which Seller has agreed to construct, own, operate and maintain a solar-powered generation facility for the generation of electric energy to be located in Iron County, in the State of Utah (as more particularly defined in the Agreement, the "Project"), and upon completion of said Project, to sell to PacifiCorp the electric energy to be produced by the Project, all on the terms and conditions set forth in the Agreement. The real property on which the Project is to be constructed (the "Premises") is more particularly described in the attached Exhibit "A".

B. Seller and PacifiCorp desire to provide record notice of certain terms and conditions of the Agreement pertaining to the Parties' respective rights and obligations under the Agreement in the event the Agreement is terminated due to a default by Seller.

NOW, THEREFORE, in consideration of the mutual covenants and obligations set forth in the Agreement and this Memorandum, Seller and PacifiCorp agree as follows:

TERMS

1. The Premises. Seller acknowledges and agrees that the real property comprising the Premises, and all improvements and fixtures to be constructed thereon, including without limitation, the Project, is and will be owned by Seller and shall hereafter be held, sold, conveyed, transferred, assigned, subdivided, leased, rented, encumbered, occupied and used subject to and in accordance with the provisions of Sections 11.4 and 11.8 of the Agreement and this Memorandum.

2. Covenants Running with the Land. The provisions of Section 11.4 and 11.8 of the Agreement are and shall be deemed to be covenants running with the land and shall be binding upon and inure to the benefit of Seller and PacifiCorp and their respective successors and permitted assigns, including without limitation any person acquiring or owning an interest in the

**CONFIDENTIAL – SUBJECT TO UTAH PUBLIC SERVICE COMMISSION RULE 746-100-16**

Premises or the Project, and their respective heirs, executors, successors, permitted assigns, administrators, devisees and representatives.

3. Notice.

a. Termination for Default. If this Agreement is terminated following the Commercial Operation Date because of a default by Seller, neither Seller (or any Affiliate), nor any successor to Seller with respect to the ownership of the Facility or Premises, may thereafter require or seek to require PacifiCorp to enter into a power purchase agreement or otherwise purchase energy or capacity from the Facility or any facility constructed on the Premises under PURPA, or any other Requirements of Law, for any periods that would have been within the Term had this Agreement remained in effect; provided, however, that such prohibition on seeking or requiring PacifiCorp to enter into a power purchase agreement or otherwise purchase energy or capacity as described above shall not apply in the event that any proposed replacement agreement incorporates the Contract Price attached hereto as Exhibit 5.1. If this Agreement is terminated prior to the Commercial Operation Date because of a default by Seller, for a period of two (2) years following the date of such termination, neither Seller (or any Affiliate), nor any successor to Seller with respect to the ownership of the Facility or Premises, may thereafter require or seek to require PacifiCorp to enter into a power purchase agreement or otherwise purchase energy or capacity from the Facility or any facility constructed on the Premises under PURPA or any other Requirements of Law using any Contract Price other than that provided in Exhibit 5.1 attached hereto. Following this two year period, Seller, Affiliate or successor to Seller may seek a new power purchase agreement with PacifiCorp for the Facility or for a facility to be constructed on the Premises, though PacifiCorp shall not be obligated to provide in such power purchase agreement avoided cost prices that are higher than the avoided cost prices contained in this Agreement for any sales of energy or capacity to PacifiCorp under that power purchase agreement prior to the expiration of five (5) years from the date this Agreement is terminated as a result of Seller's default. The parties agree that a termination of the Agreement due to the failure of the Seller to obtain a governmental approval or authorization for the Facility or Premises or a legal challenge brought by a third party to a governmental approval or authorization that has been granted for the Facility or Premises that causes prospective Lenders to refuse to provide financing for the construction of the Facility shall not be considered to be a default of the Seller for purposes of this Section 11.4 only. Terms not defined herein shall have the meaning ascribed to such terms in the Agreement.

b. Survival. The terms and provisions of Section 11.4 of the Agreement shall survive the termination of the Agreement.

4. Effect of Memorandum. This Memorandum, and the rights and obligations of the parties hereunder, are subject to all of the terms and conditions of the Agreement. The Agreement is hereby incorporated by reference as if fully set forth herein.

5. Counterparts. This Memorandum may be executed in any number of counterparts, each of which when executed and delivered shall be deemed an original, and all of which shall together constitute one and the same instrument.

6. Further Information. Further information regarding the specific terms and conditions of the Agreement may be requested from PacifiCorp at 825 NE Multnomah, Suite 2000, Portland, Oregon 97232-2315, Attn: Sr. Vice President, Commercial & Trading. Disclosure of any such information shall be subject to the terms and conditions of a written confidentially agreement





---

Exhibit "A"

---

Legal Description of the Premises

EXHIBIT 13

REQUIRED INSURANCE

1.1 Required Policies and Coverages. Without limiting any liabilities or any other obligations of Seller under this Agreement, Seller shall secure and continuously carry with an insurance company or companies rated not lower than “A-/VII” by the A.M. Best Company the insurance coverage specified below:

1.1.1 Workers’ Compensation. Seller shall comply with any applicable laws or statutes, state or federal jurisdiction, where Seller performs work.

1.1.2 Employers’ Liability. Seller shall maintain employers’ liability insurance with minimum limits covering bodily injury for: [REDACTED]

1.1.3 Commercial General Liability. Seller shall maintain insurance to include premises and operations, contractual liability, with a minimum single limit of [REDACTED] each occurrence to protect against and from loss by reason of injury to persons or damage to property based upon and arising out of the activity under this Agreement.

1.1.4 Business Automobile Liability. Seller shall secure and continuously carry business automobile liability insurance with a minimum single limit of [REDACTED] each accident covering bodily injury and property damage with respect to Seller’s vehicles whether owned, hired or non-owned.

1.1.5 Umbrella/excess Liability. Seller shall maintain umbrella or excess liability insurance on an occurrence and following form basis with a minimum limits as follows:

[REDACTED]

[REDACTED]

1.1.6 Property Insurance. Seller shall maintain property insurance covering equipment and structures in an amount at least equal to the full replacement value for “all risks” of physical loss or damage, including coverage for earth movement, flood, boiler and machinery, and business interruption. The policy may contain separate sub-limits and deductibles subject to insurance company underwriting guidelines. Property insurance will be maintained in accordance with terms available in the insurance market for similar facilities.

1.2 Additional Provisions or Endorsements:

1.2.1 Except for workers’ compensation and property insurance, the policies required herein shall include provisions or endorsements as follows:

**CONFIDENTIAL – SUBJECT TO UTAH PUBLIC SERVICE COMMISSION RULE 746-100-16**

- (a) naming PacifiCorp, parent, divisions, officers, directors and employees as additional insureds;
- (b) include provisions that such insurance is primary insurance with respect to the interests of PacifiCorp and that any other insurance maintained by PacifiCorp is excess and not contributory insurance with the insurance required hereunder, and
- (c) cross liability coverage or severability of interest.

1.2.2 Unless prohibited by applicable law, all required insurance policies shall contain provisions that the insurer will have no right of recovery or subrogation against PacifiCorp.

1.3 **Certificates.** Prior to connection of the Facility to PacifiCorp’s electric system, or another utility’s electric system if delivery to PacifiCorp is to be accomplished by wheeling, Seller shall secure and continuously carry insurance in compliance with the requirements of this Section. Seller shall provide PacifiCorp insurance certificate(s) confirming Seller’s compliance with the insurance requirements hereunder. Insurance certificate confirming compliance shall be provided to PacifiCorp by Seller at least annually and each time a new insurance policy is issued or becomes effective.

1.4 **Commercial General Liability coverage** written on a “claims-made” basis, if any, shall be specifically identified on the certificate, and Seller shall be maintained by Seller for a minimum period of five (5) years after the completion of this Agreement and for such other length of time necessary to cover liabilities arising out of the activities under this Agreement.

1.5 **Periodic Review.** PacifiCorp may review this schedule of insurance as often as once every two (2) years. PacifiCorp may in its discretion require Seller to make reasonable changes to the policies and coverages described in this Exhibit to the extent reasonably necessary to cause such policies and coverages to conform to the insurance policies and coverages typically obtained or required for power generation facilities comparable to the Facility at the time PacifiCorp’s review takes place.