



1407 W North Temple, Suite 330  
Salt Lake City, Utah 84114

April 24, 2018

***VIA ELECTRONIC FILING***

Utah Public Service Commission  
Heber M. Wells Building, 4<sup>th</sup> Floor  
160 East 300 South  
Salt Lake City, UT 84114

Attention: Gary Widerburg  
Commission Secretary

RE: Docket No. 18-035-14  
In the Matter of the Application of Rocky Mountain Power for Approval of the Pole Attachment Agreement between Rocky Mountain Power and Wasatch RSA No. 2 Limited Partnership, D/B/A Verizon Wireless

Dear Mr. Widerburg:

Rocky Mountain Power (“Company”) hereby submits for electronic filing its Application and the associated contract in the above referenced matter.

Rocky Mountain Power respectfully requests that all formal correspondence and requests for additional information regarding this filing be addressed to the following:

By E-mail (preferred): [datarequest@pacificorp.com](mailto:datarequest@pacificorp.com)  
[jana.saba@pacificorp.com](mailto:jana.saba@pacificorp.com)  
[utahdockets@pacificorp.com](mailto:utahdockets@pacificorp.com)

By regular mail: Data Request Response Center  
PacifiCorp  
825 NE Multnomah, Suite 2000  
Portland, OR 97232

Informal inquiries may be directed to Jana Saba at (801) 220-2823.

Sincerely,

  
Joelle Steward  
Vice President, Regulation

Enclosures

Daniel E. Solander (11467)  
Rocky Mountain Power  
1407 North W. Temple Suite 320  
Salt Lake City, Utah 84116  
Telephone: (801) 220-4014  
E-mail: [daniel.solander@pacificorp.com](mailto:daniel.solander@pacificorp.com)

Attorney for Rocky Mountain Power

**BEFORE THE PUBLIC SERVICE COMMISSION OF UTAH**

---

In the Matter of the Application of Rocky Mountain Power for Approval of the Pole Attachment Agreement between Rocky Mountain Power and Wasatch RSA No. 2 Limited Partnership, D/B/A Verizon Wireless

DOCKET NO. 18-035-14

**APPLICATION OF ROCKY MOUNTAIN POWER**

---

PacifiCorp, doing business in Utah as Rocky Mountain Power (“Rocky Mountain Power” or “Company”) respectfully requests an order under Utah Admin. Code R746-345-3 approving a Pole Attachment Agreement (the “Agreement”) between Rocky Mountain Power and Wasatch RSA No. 2 Limited Partnership, D/B/A Verizon Wireless (“Wasatch” or “Licensee”), dated March 13, 2018, attached hereto as Exhibit A. Rocky Mountain Power and Wasatch are referred to, individually, as a “Party” and together as the “Parties.”

In support of its Application, Rocky Mountain Power states as follows:

1. Rocky Mountain Power is a public utility in the state of Utah, subject to the jurisdiction of the Commission with regard to its rates and service. As a public utility that permits attachments to its poles by an attaching entity, Rocky Mountain Power is obligated to provide that service pursuant to Utah Admin. Rule R.746-345. Rocky Mountain has previously submitted, and received Commission approval for, non-reciprocal pole attachment agreements with several parties.
2. Communications regarding this Application should be addressed to:

By e-mail (preferred): [datarequest@pacificorp.com](mailto:datarequest@pacificorp.com)  
[jana.saba@pacificorp.com](mailto:jana.saba@pacificorp.com)  
[daniel.solander@pacificorp.com](mailto:daniel.solander@pacificorp.com)

By mail: Data Request Response Center  
Rocky Mountain Power  
825 NE Multnomah St., Suite 800  
Portland, OR 97232

Jana Saba  
Rocky Mountain Power  
1407 West N. Temple  
Salt Lake City, UT 84116  
Telephone: (801) 220-2823

Daniel E. Solander  
Rocky Mountain Power  
1407 West N. Temple, Suite 320  
Salt Lake City, UT 84116  
Telephone: (801) 220-4014

3. Under R746-345-3(B)(1), the parties to pole attachment contracts “may voluntarily negotiate an alternative contract . . . [and] shall submit the negotiated contract to the Commission for approval.” The Agreement was voluntarily negotiated between Rocky Mountain Power and Wasatch and represents the Parties’ agreed-to terms and conditions for Wasatch’s attachments to Rocky Mountain Power’s poles in Utah.

4. As with other pole attachment agreements approved by the Commission over the last several years, the Agreement negotiated between Rocky Mountain Power and Wasatch contains terms that differ from the agreement approved by the Commission on November 21, 2012, in Docket 10-035-97, known as the “Safe Harbor.”

a. The Agreement modifies the definitions by: (1) adding small cell wireless communication devices to the definition of “Equipment”; and (2) adding a definition for “Small Cell”.

b. The Agreement also: contains changes to the Application for Permission to Install Attachment section regarding changes to radio frequency, the Make-ready Work Process section, the Nonconforming Equipment section, the Tax Liability section, and the Insurance and Security Requirements provision; contains minor edits to the Term, Default, and Termination provisions; and allows assignment of the agreement without approval or consent to affiliates, subsidiaries, or any entity which acquires substantially all of licensee's assets..

c. Additional minor changes from the Safe Harbor agreement are simply nonsubstantive wording changes or are changes negotiated between the parties. A table of contents was added for convenience.

WHEREFORE, Rocky Mountain Power respectfully requests that the Commission issue an order approving the Agreement submitted herewith and find the terms and conditions of the Agreement to be just and reasonable and in the public interest.

DATED this 24<sup>th</sup> day of April 2018.

Respectfully submitted,



---

Daniel E. Solander

*Attorney for Rocky Mountain Power*

**Exhibit A**  
**Pole Attachment Agreement**

POLE ATTACHMENT AGREEMENT FOR SMALL CELL and Wi-Fi ANTENNAS

BETWEEN

ROCKY MOUNTAIN POWER

AND

WASATCH RSA NO. 2 LIMITED PARTNERSHIP, D/B/A VERIZON WIRELESS

<b>Article I.</b>	<b>DEFINITIONS .....</b>	<b>1</b>
<b>Article II.</b>	<b>SCOPE OF AGREEMENT .....</b>	<b>3</b>
Section 2.01	Grant of License; Geographic Scope; Permits.....	3
Section 2.02	Attachments; Scope .....	4
Section 2.03	Compliance with Governmental Requirements .....	4
Section 2.04	Governmental Approvals.....	4
Section 2.05	Rejection of Application .....	4
<b>Article III.</b>	<b>LICENSEE’S USE OF POLES .....</b>	<b>5</b>
Section 3.01	Application for Permission to Install Attachment .....	5
Section 3.02	Make-ready Work .....	6
Section 3.03	Pole Replacement for Licensee’s Benefit .....	7
Section 3.04	Mid-span Poles.....	7
Section 3.05	Pole Placement or Replacement for Joint Benefit of Rocky Mountain Power and Licensee.....	7
Section 3.06	Licensee’s Installation Responsibilities .....	7
Section 3.07	Conformance to Requirements and Specifications .....	8
Section 3.08	Nonconforming Equipment .....	8
Section 3.09	Interference with Rocky Mountain Power’s Equipment .....	9
Section 3.10	Expense of Situating Pole Attachments.....	9
Section 3.11	Vegetation Management .....	10
Section 3.12	Third-party Consents, Permits, Licenses, or Grants .....	10
Section 3.13	Relocation of Attachments at Rocky Mountain Power’s Option.....	10
Section 3.14	Removal of Attachments by Licensee .....	11
Section 3.15	Pole Abandonment.....	11
Section 3.16	Damage to Equipment.....	11
Section 3.17	Inspections and Audits .....	11
Section 3.18	Tax Liability.....	12
Section 3.19	Emergency Access .....	12
<b>Article IV.</b>	<b>RADIO FREQUENCY; INTERFERENCE; EMERGENCIES .....</b>	<b>12</b>
Section 4.01	Radio Frequency Emissions.....	12
Section 4.02	Interference Prohibited.....	13
Section 4.03	Preventing Interference.....	13
Section 4.04	RF Power Cut-off Switch; Emergency Condition .....	13
Section 4.05	Emergency and Emergency After Hours Contact Information.....	14
Section 4.06	Installation and Upkeep of Sign(s) .....	14
<b>Article V.</b>	<b>BILLING &amp; PAYMENTS; ANNUAL RENT .....</b>	<b>14</b>
Section 5.01	Rental Amount.....	14
Section 5.02	Fee Schedule .....	14

Section 5.03	Unauthorized Attachments.....	15
Section 5.04	Billing and Payments.....	15
Section 5.05	Interest on Late Payments.....	15
<b>Article VI.</b>	<b>INDEMNIFICATION; LIMITATION OF LIABILITY;</b>	
	<b>WARRANTIES.....</b>	<b>15</b>
Section 6.01	Indemnification/Release.....	15
Section 6.02	Warranty.....	16
<b>Article VII.</b>	<b>INSURANCE AND SECURITY REQUIREMENTS.....</b>	<b>16</b>
Section 7.01	Insurance.....	16
Section 7.02	Security.....	18
<b>Article VIII.</b>	<b>ERM, DEFAULT AND TERMINATION.....</b>	<b>19</b>
Section 8.01	Term and Termination.....	19
Section 8.02	Default.....	19
Section 8.03	Notice of Default/Cure Period.....	19
Section 8.04	Remedies for Default.....	19
<b>Article IX.</b>	<b>GENERAL PROVISIONS.....</b>	<b>20</b>
Section 9.01	Confidentiality.....	20
Section 9.02	Entire Agreement.....	20
Section 9.03	Choice of Law/Venue.....	20
Section 9.04	Changes in Law.....	20
Section 9.05	Severability.....	20
Section 9.06	Encumbrances.....	20
Section 9.07	Headings and Exhibits.....	20
Section 9.08	Force Majeure.....	21
Section 9.09	Assignments.....	21
Section 9.10	Waiver.....	21
Section 9.11	Time is of Essence.....	21
Section 9.12	No Partnership.....	21
Section 9.13	No Third-party Beneficiaries.....	21
Section 9.14	Attorneys' Fees.....	21
Section 9.15	Waiver of Jury Trial.....	22
Section 9.16	Agreement Notices.....	22
Section 9.17	Operational Notice.....	22



THIS POLE ATTACHMENT AGREEMENT (this "Agreement"), dated as of March 13, 2018, is entered into by and between PACIFICORP, an Oregon Corporation, doing business in Utah as ROCKY MOUNTAIN POWER, hereinafter "Rocky Mountain Power," and WASATCH UTAH RSA NO. 2 LIMITED PARTNERSHIP, d/b/a Verizon Wireless, a Delaware Limited Liability Company ("Licensee").

WHEREAS, Rocky Mountain Power is engaged in the business of providing electric service to customers in certain areas within the state of Utah; and

WHEREAS, Licensee conducts its wireless communications network business in some of the same areas within Utah; and

WHEREAS, Licensee wishes to attach certain wireless communication facilities communication Equipment used in connection with its business operations to Poles owned by Rocky Mountain Power within the state of Utah and Rocky Mountain Power agrees to grant Licensee access to such Poles in accordance with the terms and conditions of this Agreement;

NOW, THEREFORE, the Parties agree as follows:

#### **ARTICLE I. DEFINITIONS**

The following terms, when used in this Agreement with initial capitalization, whether in the singular or in the plural, shall have the meanings specified in this Article I:

"Application" means an action where Licensee requests permission to add or modify its Small Cell or Wi-Fi technology Attachment(s) or Equipment, or sends notification of its removal of existing Attachment(s) or Equipment.

"Attachment(s)" means any Equipment used for the transmission of Small Cell or Wi-Fi technology communications installed upon any Pole. The form of the Application is attached as Exhibit D hereto.

"Attachment Space" has the meaning set forth in UAR R746-345-2(B).

"Business Days" means days other than a Saturday, Sunday, or state or federal holiday when banks are authorized to be closed.

"Cellular Communications Site Installation Guidelines" means the current Rocky Mountain Power Cellular Communications Site Installation Guidelines (2U.1) attached as Exhibit C and any subsequent revisions.

"Commission" means the State of Utah Public Service Commission.

"Cost Estimate" means either estimates for anticipated costs on each individual piece of work or flat rates for Make-ready Work when included in the Fee Schedule (Exhibit A) and used in lieu of detailed estimates.

“Electric Facilities” means any equipment, facilities, or improvements owned by or operated by Rocky Mountain Power or a Service Provider located on Poles.

“Electric Service Requirements” means the current PacifiCorp Six State ESR document available online, as may be updated from time to time: <https://www.rockymountainpower.net/con/esr.html>

“Electronic Notification System” or “ENS” means the electronic system, or combination of electronic systems designated by the Utah Public Service Commission or by Rocky Mountain Power in its sole discretion. If an ENS is designated, Licensee must use to submit Applications for permission to attach, relocate, or submit notification of removal of its Attachments and associated Equipment, and complete any other notifications as required under this Agreement.

“Emergency Condition” means any interference or degradation by Licensee Equipment which, in Rocky Mountain Power’s sole opinion, jeopardizes its utility operations or Electric Facilities, or the operations or Electric Facilities of a Service Provider, or creates an imminent risk of physical injury.

“Equipment” means antennas and Small Cell wireless communication devices, including without limitation all support equipment such as remote radio heads (RRHs or RRUs), fiber interface boxes (e.g. SAR-O), battery backup, conduit, emergency cut-off switches, breaker boxes, guy wires, anchors, anchor rods, grounds, and other accessories which have been pre-approved in writing by Rocky Mountain Power in accordance with this Agreement.

“Estimated Attachments” means the number of Attachments Licensee estimates will be installed by Licensee under this Agreement.

“Fee Schedule” means the fees set forth in Exhibit A, as may be amended from time to time in accordance with UAR R746-345-3(A).

“Inspection” means examination by Rocky Mountain Power of Poles and all proposed or existing Attachments for the purpose of verifying the number and location of all Attachments and any other Pole-mounted Equipment of Licensee, or determining whether Licensee is in compliance with this Agreement, which includes the following types of Inspections:

1. Pre-Construction Inspection: Performed when Applications by Licensee are submitted for new Attachment(s).
2. Special Inspection: Rocky Mountain Power’s field visit made at the request of Licensee for all non-periodic Inspections. A Special Inspection does not include Pre-Construction Inspections.
3. Audit: A periodic effort to collect information through examination of all or any number of Poles that may have Licensee Attachments.

“Make-ready Work” means engineering or construction activities necessary to make a Pole available for a new Attachment, Attachment modifications, or additional facilities. Make-ready Work costs are non-recurring costs and are not contained in carrying charges as defined in UAR 746-345-5(A)(2)(a) .

“National Electrical Safety Code” or “NESC” means the current edition published by the Institute of Electrical and Electronics Engineers, Inc., as may be amended or supplemented from time to time.

“Party” means Rocky Mountain Power or Licensee, as the context requires; “Parties” means Rocky Mountain Power and Licensee.

“Permitted Purpose” means Licensee’s use of Pole(s) for the installation, operation, maintenance, replacement, repair and removal of Licensee’s Equipment for the transmission and reception of Equipment.

“Pole” means any structure owned by Rocky Mountain Power that is designed to carry electrical distribution as defined in R746-345-2(C) of the Utah Administrative Rules.

“Security” means a bond, cash escrow, letter of credit or parental guaranty, as specified by Rocky Mountain Power, to assure performance by Licensee of its obligations under this Agreement, issued on Rocky Mountain Power’s form (or any other form that is acceptable to Rocky Mountain Power in its sole discretion) by, in the case of a parental guaranty or bank issued letter of credit or other performance security, an entity whose unsecured debt obligations or long-term deposits are rated at least “A” by Standard & Poors (or the equivalent rating thereof by Moody’s) as at the date of issuance and during the term of the guaranty, letter of credit or other performance security, or, in the case of a surety issued bond or other performance security, a surety having a minimum A.M. Best Long-term Issues Credit Rating (ICR) of “a” and/or a Financial Strength Rating (FSR) of “A” as at the date of issuance and otherwise during the term of the bond or other performance security.

“Service Provider” means a company, other than Rocky Mountain Power, providing electrical utility service.

“Small Cell” means any Licensee-controlled installation of low-powered radio frequency access nodes on Poles that sends and/or receives radio frequency signals including those that operate in licensed and unlicensed spectrums.

“Wi-Fi Antenna Installation Guidelines” means the current Rocky Mountain Power Wi-Fi Antenna Installation Guidelines (2U.2) attached as Exhibit C, and any subsequent revisions.

## **ARTICLE II. SCOPE OF AGREEMENT**

### **Section 2.01 Grant of License; Geographic Scope; Permits**

In accordance with the terms and conditions of this Agreement, Rocky Mountain Power grants Licensee the non-exclusive right to attach its Attachment(s) and associated Equipment for Licensee’s Permitted Purpose. Licensee Attachments hereunder are limited to Poles within the state of Utah.

Consistent with UAR 746-345-5, permitted Attachment(s) on a Pole will be measured in increments of not less than one (1) foot. The amount of annual contact rent (Exhibit A) will be determined by the amount of space on the Pole rendered unusable for other uses as a result of the

Attachment. If additional Attachments are placed within the same space as previously permitted, and are compliant with this Agreement, no additional annual contact rental will be required. If additional Attachments will be placed on the Pole outside the previously permitted space, additional space will be added in one (1) foot increments for calculation of annual contact rental.

Initial installation of Small Cell and Wi-Fi Attachments requires Application and prior approval by Rocky Mountain Power and are subject to annual rent. Rigid riser installations require Application and prior approval by Rocky Mountain Power, but no annual rent.

Section 2.02      Attachments; Scope

Licensee's use of Poles will be confined to Attachments needed for the Permitted Purpose. Under no circumstances will Licensee place any signage, logos, or graphics on Poles or Licensee's Equipment, except for standard equipment labels signage required by law or required under this Agreement.

Attachments to Poles that are not designed to accommodate distribution lines will be reviewed and approved at Rocky Mountain Power's sole discretion. Nothing in this Agreement will be construed to obligate Rocky Mountain Power to grant Licensee permission to use any particular Pole or Poles. The Agreement expressly excludes Licensee macro cell technology, wireline attachments and attachments to Rocky Mountain Power street light only poles.

Section 2.03      Compliance with Governmental Requirements

Licensee's use of Poles will be in compliance with all applicable laws, orders, ordinances, and regulations of federal, state, county and municipal authorities and agencies ("Governmental Authorities"), including but not limited to the Federal Communications Commission ("FCC").

Section 2.04      Governmental Approvals

Licensee will, at its own expense, obtain all authorizations, approvals, permits, licenses, variances, and certifications required for the Permitted Purpose from Governmental Authorities having jurisdiction, including but not limited to, all necessary zoning, land use, or similar approvals, and all certificates of public convenience and necessity, licenses, or similar operational authority from the FCC ("Governmental Approvals"). Rocky Mountain Power will reasonably cooperate with Licensee, at Licensee's sole expense, in obtaining Governmental Approvals.

Section 2.05      Rejection of Application

Rocky Mountain Power reserves the right, in its reasonable judgment, to reject Applications for attachment to Poles for the following reasons:

- a. Insufficient capacity, after all reasonable potential accommodations have been considered by Rocky Mountain Power and communicated to Licensee.
- b. Threat to Rocky Mountain Power's system reliability.
- c. Proposed Attachment and/or associated Equipment is considered to be unsafe according to the NESC, Cellular Communications Site Installation Guidelines (Exhibit B) or Wi-Fi Antenna Installation Guidelines (Exhibit C).
- d. Unreasonable interference, as determined by Rocky Mountain Power, with Rocky Mountain Power's equipment.

- e. Already a wireless device or antenna on Pole or approved to attach to Pole that creates a safety or design related problem under Rocky Mountain Power's standards that cannot be reasonably resolved to Rocky Mountain Power's satisfaction.
- f. Licensee is in default of this Agreement beyond the applicable notice and cure period.

### **ARTICLE III. LICENSEE'S USE OF POLES**

#### Section 3.01 Application for Permission to Install Attachment

Licensee must not place any Attachment or associated Equipment upon Poles without first submitting an Application and receiving Rocky Mountain Power's written approval. Licensee must not modify the position of any Attachment upon any Poles outside the space approved in the relevant Application without first submitting an additional Application and receiving Rocky Mountain Power's written approval. Licensee may modify, replace, enhance, maintain, and upgrade its Attachments and Equipment without submitting a new Application, so long as such work does not materially alter its Equipment, or increase Pole loading beyond the Pole loading established in the relevant Application and conforms with Section 3.07. Licensee shall not be required to submit a new Application for changes to the radio frequency ("RF") provided that Licensee can demonstrate, if requested by Rocky Mountain Power, that the change will not cause any interference with existing equipment on the Pole. If Licensee's modification, replacement, enhancement, maintenance or upgrade materially alters its Equipment, an Application is required in accordance with this Section 3.01. Attachments or Equipment found upon Poles without required written approval is subject to unauthorized Attachment fees under Section 5.03 of this Agreement.

Licensee's Application to place any Equipment upon Poles must be submitted via the Commission approved Electronic Notification System (ENS). The Application must include: all location information including Rocky Mountain Power's Pole numbers; amount of space requested (including space rendered unusable for other uses by Licensee's Attachment); type and number of Attachments and Equipment to be attached on each Pole; Attachment location on the Pole; physical characteristics of Attachment(s) including dimensions; description of installation; indication of known required Make-ready Work as outlined in Section 3.02; proposed schedule for construction; and all applicable contact information for the Licensee or Licensee's qualified contractor. Rocky Mountain Power will approve, approve with condition, or deny Applications in writing in accordance with requirements of UAR R746-345-3. If the Application is rejected for insufficient information from the Licensee, the timelines outlined in UAR R746-345-3 will be suspended until Licensee provides the required information to Rocky Mountain Power.

Licensee will promptly submit payment for all charges applicable to the assessment of proposed Attachments in accordance with the Fee Schedule (Exhibit A) upon receipt of an invoice from Rocky Mountain Power in accordance with Section 5.04. Rental charges for each approved Attachment will be in accordance with Section 5.01 and Electric Service Schedule No. 4 (Exhibit A).

Section 3.02            Make-ready Work

Licensee must identify in its Applications any Make-ready Work necessary to accommodate Attachments. If Licensee identified necessary Mark-ready Work or Rocky Mountain Power determines in its reasonable judgment that the accommodation of any Attachment(s) necessitates Make-ready Work, Rocky Mountain Power will provide Licensee with the Cost Estimate of the Make-ready Work in accordance with requirements of UAR 746-345-3. Rocky Mountain Power reserves the right to determine when a flat rate is applicable according to the specific situation provided that the flat rate is reasonable related to the scope of the work required. Licensee may request a detailed estimate for work where Rocky Mountain Power has provided a flat rate Cost Estimate.

Licensee must indicate whether it accepts the Cost Estimate by returning Rocky Mountain Power's Make-ready Work notice, signed by an authorized representative of Licensee, within thirty (30) days of the date Rocky Mountain Power approved the Application. If Licensee accepts the Cost Estimate, Rocky Mountain Power will perform the Make-ready Work, and Licensee will reimburse Rocky Mountain Power for the entire expense actually incurred, without regard to whether Licensee elects not to use the Pole or Poles after Make-ready Work has commenced. If requested by Rocky Mountain Power, Licensee must submit pre-payment for the estimated Make-ready Work in accordance with UAR 746-345-3(C)(7). Upon request, Rocky Mountain Power will provide Licensee a statement of the actual material, hours, equipment costs, and any other associated costs for payment of Make-ready Work.

Rocky Mountain Power will provide Licensee an estimated completion date for any Make-ready Work, taking into account the timeframes set by UAR 746-345-3, the overall scope of Licensee's project, the volume of Applications received from other licensees, as well as the availability of crews to perform the work. Licensee and Rocky Mountain Power will negotiate solutions in good faith when the estimated time to perform the Make-ready Work does not meet Licensee's project requirements. At Licensee's option and upon approval from Rocky Mountain Power, Licensee may request either assistance with the work by Licensee or by qualified contractors hired by Licensee, payment of premium rates for Rocky Mountain Power's employees to be dedicated to perform work solely on Licensee's project, or similar measures designed to augment Rocky Mountain Power's capabilities. Licensee reserves all rights to employ a self-build option as provided in UAR 746-345-3(C). If Licensee chooses to employ a self-build option as provided in UAR 746-345-3(C) to complete the Make-ready Work, to ensure safety and reliability, the qualified contractor and the schedule must be approved by Rocky Mountain Power.

Section 3.02 (a)            Make-Ready Work Associated with an Application

Licensee's failure to accept the Cost Estimate associated with an Application within thirty (30) days of Rocky Mountain Power's Cost Estimate of Make-ready Work will be deemed as rejection of the Make-ready Work and revocation of Application to attach to Pole(s) requiring Make-ready Work. Upon rejection of a Cost Estimate, Rocky Mountain Power will cancel the Cost Estimate and close the Application request. If Licensee determines at a later date that it still wishes to attach, Licensee must submit a new Application for the Attachment(s). Licensee must reimburse Rocky Mountain Power for reasonable costs related to preparation of a Make-ready Work Cost Estimate, regardless of whether Licensee accepts or rejects the Make-ready Work.

Section 3.02 (b) Make-Ready Work Associated with Conformance to Requirements and Specifications

Rocky Mountain Power will prepare a Cost Estimate for Make-ready Work under Section 3.07. Failure to accept or reject such Cost Estimate within thirty (30) days will be deemed as acceptance by Licensee. If Licensee accepts or fails to timely reject the Cost Estimate, Rocky Mountain Power may perform such Make-ready Work, and Licensee must reimburse Rocky Mountain Power for the entire expense actually incurred, without regard to whether Licensee elects not to use the Pole or Poles after Make-ready Work has commenced. Licensee must pay Rocky Mountain Power for costs related to preparation of a Make-ready Work Cost Estimate, regardless of whether Licensee accepts or rejects the Cost Estimate.

Section 3.03 Pole Replacement for Licensee's Benefit

In the event an existing Pole is prematurely replaced by a new Pole for the benefit of Licensee, Licensee must reimburse Rocky Mountain Power for all reasonable costs, including, but not limited to, the cost to replace the Pole, transfer of existing Rocky Mountain Power equipment, lower and haul of the existing Pole, and topping of the existing Pole. Rocky Mountain Power may also charge return trip costs to Licensee in accordance with the Fee Schedule (Exhibit A) or actual cost when incurred by Rocky Mountain Power to return to the work site to lower and haul the existing Pole after either the Licensee or other attachers have transferred existing Attachments, when such existing Pole is prematurely replaced by a new Pole for the benefit of Licensee. Rocky Mountain Power will remove and may retain or dispose of such Pole. Any payments for Poles made by Licensee shall not entitle Licensee to ownership of any part of said Poles.

Section 3.04 Mid-span Poles

Any Poles erected by Licensee will not interfere with, or be in-line with Poles, and will not create a structure conflict as defined in the NESC. If Licensee requires placement of a Pole in-line with any existing Poles (i.e., a "mid-span Pole"), Licensee will submit an Application requesting such mid-span Pole and Rocky Mountain Power will determine, in its reasonable discretion whether it will place a Pole in the requested location. If Rocky Mountain Power installs a mid-span Pole in accordance with this Section 3.04, Licensee will pay all reasonable installation costs. Rocky Mountain Power will have sole ownership of the mid-span Pole and Licensee will pay rental fees to Rocky Mountain Power in accordance with this Agreement.

Section 3.05 Pole Placement or Replacement for Joint Benefit of Rocky Mountain Power and Licensee

Where Rocky Mountain Power requires a new Pole for its utility purposes irrespective of Licensee's Attachment and Licensee requires a Pole with extra height or strength exceeding Rocky Mountain Power's requirements, Licensee will pay to Rocky Mountain Power a sum equal to the difference between the actual cost of erecting a Pole adequate to meet Rocky Mountain Power's needs, and the actual cost of erecting a Pole adequate to meet both Parties' needs. Rocky Mountain Power will bear the remainder of the cost of erecting such Pole. Each Party will transfer its Equipment at its own cost.

Section 3.06 Licensee's Installation Responsibilities

Licensee must complete the installation of its Attachments upon the Pole(s) covered by each

approved Application within one hundred eighty (180) days following receipt of approval by Rocky Mountain Power of such Application, unless Rocky Mountain Power agrees in writing to a longer time period. Licensee must provide written notice to Rocky Mountain Power of its completion within five (5) Business Days of the actual installation.

If Licensee fails to complete installation of its Attachments within the prescribed time limit, Rocky Mountain Power's approval to place Attachments upon the Pole or Poles will be automatically revoked. Licensee must reapply and receive permission to install, in accordance with Section 3.01. Licensee's failure to install its Equipment after receiving approval from Rocky Mountain Power will not entitle Licensee to a refund or reduction of fees or rental charges incurred for its proposed Attachments unless such failure is due to the exclusive fault of Rocky Mountain Power.

#### Section 3.07 Conformance to Requirements and Specifications

Licensee will, at its sole risk and expense, place and maintain its Attachment(s) upon Pole(s) in conformity with the requirements and specifications of the NESC, the FCC, and specifications as Rocky Mountain Power may from time to time prescribe, including without limitation the current Cellular Communications Site Installation Guidelines (Exhibit B) and/or Wi-Fi Antenna Installation Guidelines (Exhibit C). In the event of any conflict between any of the requirements and specifications of the NESC, FCC, and those prescribed by Rocky Mountain Power, the more stringent requirements and specifications will govern.

Any request for electric service must comply with the current PacifiCorp Electric Service Requirements available through Rocky Mountain Power's website.

Licensee (including its employees and contractors) will not enter Rocky Mountain Power's electric utility space for any purpose including making connections to Rocky Mountain Power's neutral. If Licensee requires grounding on an existing Pole where a grounding conductor does not exist, Licensee must request that Rocky Mountain Power install grounding. Grounding will be installed at the sole expense of Licensee. Licensee, its employees and its contractors, will at all times exercise Licensee's rights and perform Licensee's responsibilities under the terms of this Agreement in a manner that treats all Electric Facilities of Rocky Mountain Power as energized at all times.

Licensee will have in place a facility inspection program that meets the requirements of this section and Licensee will provide Rocky Mountain Power with documentation of Licensee's program upon written request. Licensee will also utilize Rocky Mountain Power's electronic system for updating status of communicated nonconforming conditions.

#### Section 3.08 Nonconforming Equipment

If any Attachment is not installed and maintained in accordance with Section 3.077, Rocky Mountain Power reserves the right to correct any nonconformance, which may include removal of Licensee's Equipment, upon Licensee's failure to do so after thirty (30) days' written notice from Rocky Mountain Power. Such work will be performed at Licensee's sole risk and expense. If Rocky Mountain Power determines the conditions pose an immediate threat to the safety of utility workers or the public, interfere with the performance of Rocky Mountain Power's service obligations, or pose an immediate threat to the integrity of Poles or other electric facilities, Rocky



Mountain Power may make necessary corrections without prior notice at the sole risk and expense of Licensee. As soon as practicable thereafter, Rocky Mountain Power will notify Licensee in writing of the work performed. Licensee will pay all reasonable costs incurred by Rocky Mountain Power in making corrections to Attachments.

To the extent Rocky Mountain Power and the Licensee agree the Licensee has not caused non-compliance with the NESC, FCC or Rocky Mountain Power standards, Licensee will not be responsible for correction costs. However, if the cost causer is undetermined, Licensee will share in the cost of correction.

#### Section 3.09 Interference with Rocky Mountain Power's Equipment

If, in Rocky Mountain Power's reasonable judgment, Licensee's existing Attachments on any Pole interfere with Rocky Mountain Power's existing facilities, Rocky Mountain Power will notify Licensee in writing of rearrangements or transfers of Licensee's Attachment, Pole replacements or other changes required in order to continue to accommodate Licensee's Attachments in a manner comparable to the existing locations of the Attachments. This notice will include a Cost Estimate for any applicable Make-ready Work by Rocky Mountain Power to accommodate Licensee's continued Attachment in a comparable manner.

If Licensee wishes to continue to maintain its Attachments on a Pole where a Cost Estimate has been provided for Make-ready Work to be completed by Rocky Mountain Power, it will return Rocky Mountain Power's notice of the Cost Estimate, signed by an authorized representative, within thirty (30) days. Rejection of Cost Estimates must be made in writing within thirty (30) days. If Licensee accepts or fails to timely reject the Cost Estimate, Rocky Mountain Power may perform such Make-ready Work, and Licensee will reimburse Rocky Mountain Power for the reasonable expense actually incurred, without regard to whether Licensee elects to remove Attachments after Make-ready Work has commenced.

If Licensee does not accept the cost to accommodate its continued Attachment, Licensee must remove its Attachments from the affected Pole or Poles within thirty (30) days of written notification by Rocky Mountain Power. Licensee must notify Rocky Mountain Power in writing of its removal within five (5) Business Days of completion of the removal.

If Licensee has not removed its Attachments at the end of the thirty (30) day period Rocky Mountain Power may remove Licensee's Equipment at Licensee's sole risk and expense, and Licensee will reimburse Rocky Mountain Power all reasonable costs.

#### Section 3.10 Expense of Situating Pole Attachments

Licensee will place, maintain, rearrange, transfer, and remove its own Attachments at its own expense except as otherwise expressly provided in this Agreement.

When an existing Attachment requires modification by Licensee solely for a third-party's benefit, Licensee must coordinate with such third-party. Rocky Mountain Power will facilitate only to the extent of notifying the third-party that the third-party must coordinate with Licensee to effectuate the modification. If the third-party is an occupant, Rocky Mountain Power will provide the third-party's contact information to Licensee. If the third-party is not an occupant, Rocky Mountain

Power will notify Licensee and provide the location of the Pole at issue. Nothing in this Agreement prohibits Licensee from seeking reimbursement for costs it incurs from third-party requests; however, all required work to be completed by Licensee must meet the reasonable timeframe prescribed by Rocky Mountain Power without regard to third-party cost recovery negotiations.

Section 3.11 Vegetation Management

All vegetation management in connection with the initial placement of an Attachment will be undertaken entirely by the Licensee at its sole risk and expense. Unless agreed to otherwise, each occupant is responsible for any and all vegetation management related to the facilities it owns. If Licensee fails to fulfill its obligations of this Section 3.11, Rocky Mountain Power will provide written notice to Licensee that if the issue is not resolved within thirty (30) days, Rocky Mountain Power will perform the required remedy at Licensee's sole risk and expense.

Section 3.12 Third-party Consents, Permits, Licenses, or Grants

Licensee is solely responsible for obtaining from public authorities and private owners of real property and maintaining in effect any and all consents, permits, licenses or grants necessary for the lawful exercise by Licensee of the permission granted by Rocky Mountain Power under this Agreement. Rocky Mountain Power, at any time, may require Licensee to submit written documentation of compliance with this Section 3.12 within thirty (30) days of written notice from Rocky Mountain Power. Upon notice from Rocky Mountain Power to Licensee that necessary permission for the use of any Pole or Poles has expired, or has not been secured from property owners or public authorities, any permission granted covering the use of such Pole or Poles shall immediately terminate and Licensee must remove its Equipment from the affected Pole or Poles within thirty (30) days of said notice, or within the period required by the property owners or public authorities, whichever is shorter, unless Licensee demonstrates that such approval for the use of any Pole or Poles has not expired, or has been secured from property owners or public authorities. Notwithstanding the foregoing, if Licensee has commenced legal action to establish its rights and is legally permitted to use the Pole or Pole(s) pending such legal action, Rocky Mountain Power will allow Licensee to maintain its Attachment while pursuing those efforts, provided Licensee defend, indemnify and hold harmless Rocky Mountain Power for all loss and expense that results from Licensee's continued use of the Pole or Pole(s). If Licensee ultimately fails to establish its rights or has not removed its Attachment within the stated period, Rocky Mountain Power may remove Licensee's Equipment from such Poles without incurring any liability and Licensee will reimburse Rocky Mountain Power all reasonable costs incurred by Rocky Mountain Power in the removal of Licensee's Equipment.

Section 3.13 Relocation of Attachments at Rocky Mountain Power's Option

Licensee will at any time at its own sole risk and expense, upon written notice from Rocky Mountain Power, relocate, replace, repair, or perform any other work in connection with the Attachments that may be required by Rocky Mountain Power, within thirty (30) days unless another timeframe is specified in writing by Rocky Mountain Power, provided that a shorter timeframe shall not be required by Rocky Mountain Power except for good cause e.g. to meet requests by governmental agencies. Licensee will provide written notification to Rocky Mountain Power within five (5) Business Days of its completion.

Section 3.14      Removal of Attachments by Licensee

Licensee may at any time remove its Attachments from any of the Poles and, in each case, Licensee must give Rocky Mountain Power written notice of such removal within five (5) business days. Removal of the Attachments from any Pole is a termination of Licensee's right to use such Pole. Licensee will not be entitled to a refund of any rent for any removal. After removal of Attachments, the applicable Attachment count will be reduced in the next annual billing cycle following Licensee's proper notice to Rocky Mountain Power of the removal. When Licensee performs maintenance to or removes or replaces its Attachment on a Pole, Licensee must chemically treat all field drilled holes and plug any vacated holes, including those resulting from removal of Attachment. If Licensee fails to adequately plug and treat such holes, Rocky Mountain Power may do so at Licensee's sole risk and expense.

Licensee's failure to remove Attachment(s) in accordance with any notice of removal will be subject to an unauthorized Attachment fee in accordance the Fee Schedule (Exhibit A).

Section 3.15      Pole Abandonment

If Rocky Mountain Power abandons any Pole, Rocky Mountain Power will give Licensee written notice at least ninety (90) days prior to the date on which it intends to abandon such Pole. If after ninety (90) days, Rocky Mountain Power and any third-parties have no facilities on such Pole but Licensee's Attachments remain, upon execution of a transfer of ownership, the Pole will become the property of Licensee "as is" and Licensee will hold harmless Rocky Mountain Power from all obligations, liabilities, damages, costs, expenses or charges incurred thereafter arising out of the presence, location or condition of such Pole or any of Licensee's Attachments thereon. Should Rocky Mountain Power relinquish ownership of any Pole to another party, Rocky Mountain Power will notify Licensee at least ninety (90) days prior to the date on which ownership will assumed by the new party.

Section 3.16      Damage to Equipment

Licensee will exercise all necessary precautions to avoid causing damage to Rocky Mountain Power's Poles and associated facilities as well as third-party facilities. Licensee will assume responsibility for any and all loss from any such damage caused by Licensee and will reimburse Rocky Mountain Power for the actual reasonable expense incurred to repair the damage.

Section 3.17      Inspections and Audits

*Inspections.* Rocky Mountain Power may perform reasonable Inspections of Licensee's Attachments upon Poles. Rocky Mountain Power has the right to charge Licensee for a Pre-Construction Inspection (other than Audits) for each of Licensee's proposed Attachments upon Poles which cost is included in the per Pole application fee (Exhibit A). In addition, Rocky Mountain Power may charge Licensee for the reasonable expense of any other Inspections requested by Licensee.

*Audits.* Rocky Mountain Power may conduct an Audit of Attachments made to its Poles no more frequently than once every five (5) years. Rocky Mountain Power will give Licensee at least ninety (90) days prior written notice of an initial meeting to plan Audits. At such meeting, Rocky Mountain Power, Licensee and all other occupants in attendance will, among other things, review the predicted costs to perform an Audit, the selection of an independent contractor for conducting

the Audit, and the scheduling, scope, extent and reporting of the Audit results. Regardless of whether Licensee attends the Audit planning meeting or expresses an intention to participate in the Audit, Rocky Mountain Power will notify Licensee in writing at least sixty (60) days before the commencement of the Audit. Licensee must notify Rocky Mountain Power in writing if Licensee wishes to participate in the Audit not less than thirty (30) days before the scheduled date of the Audit. The data from the Audit will be made available to Licensee and all other occupants and used to update the Parties' records. A Party must object to the Audit results within ninety (90) days of receipt of the Audit report or such objections are waived.

The cost of the Audit shall be included in the carrying charge for the rental rate in accordance with the methodology approved by the Commission for such purposes. If during an Audit, occupants request items to be added to the Audit beyond the scope predicated in the carrying charge, the additional costs for including those items in the Audit will be the sole responsibility of the party requesting them.

#### Section 3.18 Tax Liability

Licensee will promptly pay any tax, fee, or charge that may be levied or assessed against Poles or Rocky Mountain Power's property directly related to the use by Licensee. If Licensee fails to pay any such tax or assessment on or before the date such tax or assessment becomes delinquent, Rocky Mountain Power, at its own option, may pay such tax on account of Licensee and Licensee will reimburse Rocky Mountain Power for the full amount of tax and any penalties paid. Notwithstanding the foregoing, Licensee shall not be obligated to pay, nor shall Rocky Mountain Power be entitled to pay on account of Licensee, any tax, assessment, or charge that Licensee is disputing in good faith in appropriate proceedings prior to a final determination that such tax is properly assessed provided that no lien attaches to the applicable Poles.

#### Section 3.19 Emergency Access

In the case of emergencies, Rocky Mountain Power may require removal or relocation of Licensee's Attachments within the reasonable time period necessitated by the emergency. If Licensee fails to complete the relocation or removal within the necessary time period, Rocky Mountain Power may remove or relocate Licensee's Attachments at Licensee's sole risk and expense and Licensee must reimburse Rocky Mountain Power for the costs. Rocky Mountain Power will, to the extent practicable, provide notice to Licensee via Licensee's emergency contact number set forth in Section 9.17 prior to removing or relocating Licensee's Attachments in accordance with this Section 3.19. Where prior notice is not possible, Rocky Mountain Power will notify Licensee of any such removal or relocation as soon as practicable thereafter.

### **ARTICLE IV. RADIO FREQUENCY; INTERFERENCE; EMERGENCIES**

#### Section 4.01 Radio Frequency Emissions

Licensee is solely responsible for RF emissions emitted by its Equipment. Licensee is responsible for ensuring RF exposure from RF emissions emitted by its Equipment, in combination with the emissions of all other contributing sources of RF emissions that pre-exist Licensees' Equipment, is within the limits allowable under all applicable rules of the FCC. Licensee must install appropriate signage readable from the ground without the use of optical aides to notify workers

and third-parties of the potential for exposure to RF emissions. Licensee will communicate and cooperate with other occupants that emit RF to minimize the number of signs.

Section 4.02      Interference Prohibited

Licensee will not allow the transmission of its RF signals to interfere with or degrade Rocky Mountain Power's transmission of authorized radio frequencies or Rocky Mountain Power facilities, or other occupants. Licensee and other occupants who emit RF through Attachments on Poles are under a duty and obligation in connection with the operations of their own facilities, now existing or in the future, to protect RF interference with the RF signals of any other such occupants, as applicable. Licensee will, at its own cost, cooperate and eliminate any such interference or degradation to other RF networks created by its RF emissions and work with other RF emitters as needed relating to the same as soon as practicable upon written notice by Rocky Mountain Power. Rocky Mountain Power shall not allow other occupants who emit RF through Attachments on Poles to interfere with or degrade Licensee's transmission of authorized radio frequencies or Licensee's facilities.

Section 4.03      Preventing Interference

To prevent interference, Licensee will provide Rocky Mountain Power with written plans for any material alteration to Licensee's Equipment, including any RF change or additions outside of Licensee's authorized frequency band. Such plans must be submitted to Rocky Mountain Power at least forty-five (45) days before commencing the alterations via the application process (Section 3.01). Rocky Mountain Power will notify Licensee in writing of any material modifications to Rocky Mountain Power's facilities that it reasonably determines may present a substantial risk of interference with Licensee's Equipment. If Licensee determines in its sole discretion that it is not technically or economically practical to correct interference caused by Rocky Mountain Power's modification, Licensee may submit a removal notice via Rocky Mountain Power's approved ENS with no further obligations or liability thereunder except the obligations accrued through removal of Licensee's Attachments and associated Equipment.

Section 4.04      RF Power Cut-off Switch; Emergency Condition

Licensee must install and maintain a disconnect switch that can be operated manually and/or remotely for the purpose of powering down Licensee's Equipment and all battery backups in the event of an emergency. Licensee must place and maintain signage on Pole(s) and any Licensee Equipment cabinet. The signage must meet FCC requirements and contain the site identification number, a contact phone number for the purpose of requiring Licensee to power down its Equipment, and a notice that the Equipment has battery backup when the disconnect switch to Rocky Mountain Power's system is open. The signage must not be subject to discoloring or peeling away. Rocky Mountain Power's authorized field personnel will notify Licensee's designated point of contact not less than twenty-four (24) hours in advance of the need for a temporary power shut-down or if the nature of the emergency warrants more immediate action as soon as reasonably practicable. Licensee must immediately and completely shut off all power to its Equipment upon request from Rocky Mountain Power. In the event Licensee fails to do so, in addition to exercising any other remedy Rocky Mountain Power may have, Rocky Mountain Power may disable, or cause to be disabled, either manually or remotely, any and all of Licensee's Equipment that creates or exacerbates an Emergency Condition. Rocky Mountain Power will not

be liable to Licensee for actions taken in a reasonable good faith belief that Licensee's transmissions or other acts or omissions are creating or exacerbating an Emergency Condition. Rocky Mountain Power will, as soon as reasonably possible after disabling Licensee's Equipment, notify Licensee of such action, which notice may be made in accordance with Section 4.05.

Section 4.05      Emergency and Emergency After Hours Contact Information

Licensee must provide emergency after hours contact information to Rocky Mountain Power to ensure proper notification in case of an Emergency Condition. Information will include 24/7 telephone and cellphone information, a list of contacts by district (if applicable) and escalation procedures. Licensee will also provide contacts for Emergency Conditions that arise during normal business hours.

Section 4.06      Installation and Upkeep of Sign(s)

Licensee is responsible for the installation and upkeep of its signage on each Pole as required by law and this Agreement. The signage will be placed so that it is clearly readable from the ground without the use of optical aides. Signage will contain the information approved for such signs by the FCC, or in the absence of FCC approval, the information commonly used in the industry for such signs.

**ARTICLE V.      BILLING & PAYMENTS; ANNUAL RENT**

Section 5.01      Rental Amount

Licensee must pay to Rocky Mountain Power, in advance, on an annual basis under a billing cycle beginning July 1, a rental amount computed in accordance with UAR R746-345-5(A) and Electric Service Schedule 4 (Exhibit A).

The amount of annual contact rent (Exhibit A) for each Attachment will be in accordance with UAR 746-345-5(A)(3)(d)(v) and based on Rocky Mountain Power's tabulation of Licensee's Attachments situated upon Rocky Mountain Power's Poles and based upon Rocky Mountain Power's current records.

The rental rate does not include the costs of Application processing, Inspections (other than Audits and Periodic Safety Inspections), Make-ready Work, and the costs related to unauthorized Attachments as addressed in Section 5.03. Charges for activities not included in the rental rate will be based on actual costs, including administrative costs, or flat rates specified in Exhibit A, and will be charged in addition to the rental rate. Parties recognize that rates will change consistent with approved changes to Electric Service Schedule 4 (Exhibit A).

Section 5.02      Fee Schedule

Rocky Mountain Power's Fee Schedule (Exhibit A) sets forth flat rates for work or activities performed by Rocky Mountain Power and invoiced to Licensee. Work and activities performed by Rocky Mountain Power not included in the Fee Schedule will be invoiced at actual cost.

Section 5.03      Unauthorized Attachments

Licensee must not make Attachments to Rocky Mountain Power's Poles without obtaining Rocky Mountain Power's written permission as provided for in this Agreement. Rocky Mountain Power may charge Licensee an unauthorized Attachment fee as shown on Exhibit A, upon the discovery of unauthorized Attachments belonging to Licensee. In addition to such fees, back rent will be charged for the lesser of 5 years or the period of unauthorized Attachment. The imposition of such charges will be without prejudice to Rocky Mountain Power's right to utilize additional other remedies, including, but not limited to, the remedies available for default under Article VIII of this Agreement and any remedies available under Commission rules. Licensee may avoid unauthorized Attachment fees, except back rent, if it self-discloses unpermitted Attachments and makes an Application for said Attachment pursuant to Section 3.01 prior to Rocky Mountain Power's discovery.

Section 5.04      Billing and Payments

Rocky Mountain Power will send invoices to Licensee via electronic mail (e-mail) to the address(es) provided by the Licensee in writing. Licensee must pay all charges within forty-five (45) days of the invoice date. Interest will be imposed on any delinquent amounts as specified in Section 5.05 of this Agreement.

If Licensee disputes an invoice, Licensee will provide written notice of the dispute to Rocky Mountain Power within forty-five (45) days of the date of the disputed invoice, otherwise Licensee forfeits its right to dispute the invoice, except as provided by Commission rule. Notice of dispute must include a detailed explanation of the dispute. Rocky Mountain Power may impose interest as specified in Section 5.05 of this Agreement if the Licensee's dispute is not made in good faith.

Licensee will provide its accounts payable address(es) in writing and any future changes to the address(es) in writing sixty (60) days prior to the date of the change. Copies of individual invoices may be requested in writing to be forwarded to an alternate address upon each written request.

Section 5.05      Interest on Late Payments

All amounts payable under the provisions of this Agreement are payable, unless otherwise specified, within forty-five (45) days of the invoice date. An interest charge at the higher of one and one-half percent (1.5%) per month or the maximum rate allowed by applicable law will be assessed against all late payments.

**ARTICLE VI.      INDEMNIFICATION; LIMITATION OF LIABILITY; WARRANTIES**

Section 6.01      Indemnification/Release

To the fullest extent permitted by law, Licensee will indemnify, protect, and hold harmless Rocky Mountain Power and its directors, officers, employees and agents (collectively, the "Rocky Mountain Power Indemnified Parties") against and from any and all claims, demands, suits, losses, costs and damages of every kind and description, including attorneys' fees and/or litigation expenses, brought or made against or incurred by the Rocky Mountain Power Indemnified Parties resulting from, arising out of, or in any way connected with any act, omission, fault or negligence of Licensee, its employees, agents, representatives or contractors, their employees, agents or representatives in the performance or nonperformance of Licensee's obligations under this

Agreement or in any way related to this Agreement except to the extent that such claim, demand, loss, cause of action, or costs arises from Rocky Mountain Power's gross negligence or willful misconduct. Licensee will also indemnify and release, protect and hold harmless the Rocky Mountain Power Indemnified Parties from and against any and all claims, demands, causes of action, costs (including attorneys' fees), or other liabilities arising from any interruption, discontinuance, or interference with Licensee's service to its customers which may be caused, or which may be claimed to have been caused, by any action of Rocky Mountain Power undertaken in furtherance of the purposes of this Agreement. Additionally, Licensee will, upon demand, and at its own sole risk and expense, defend any and all suits, actions, or other legal proceedings which may be brought against Rocky Mountain Power Indemnified Parties, on any claim, demand, or cause of action arising from any interruption, discontinuance, or interference with Rocky Mountain Power's service to Rocky Mountain Power's customers which may be caused, or which may be claimed to have been caused, by any act, omission, fault or negligence of Licensee. If Licensee is required to indemnify under Section 6.01, Licensee will pay and satisfy any judgment or decree that may be rendered against Rocky Mountain Power Indemnified Parties, in any such suit, action, or other legal proceeding; and further, Licensee will reimburse Rocky Mountain Power for any and all legal expenses, including reasonable attorneys' fees, incurred in connection therewith, including appeals thereof. Licensee hereby releases Rocky Mountain Power from any liability for damage to Equipment, or for any interruption, discontinuance or interference with Licensee's service to its customers, caused by or resulting from Rocky Mountain Power's actions or inaction, including damages caused by or resulting from such removal, including damages caused Rocky Mountain Power's ordinary negligence.

Section 6.02      Warranty

Rocky Mountain Power warrants that its work in constructing and maintaining the Poles covered by this Agreement shall be consistent with prudent utility practices. **ROCKY MOUNTAIN POWER DISCLAIMS ALL OTHER WARRANTIES, EXPRESS OR IMPLIED, INCLUDING BUT NOT LIMITED TO THE WARRANTY OF MERCHANTABILITY, FITNESS FOR PARTICULAR PURPOSE, AND SIMILAR WARRANTIES.** Under no circumstances will Rocky Mountain Power be liable for economic losses, costs or damages, including but not limited to special, indirect, incidental, punitive, exemplary or consequential damages.

**ARTICLE VII.      INSURANCE AND SECURITY REQUIREMENTS**

Section 7.01      Insurance

Without limiting any liabilities or any other obligations of Licensee, Licensee must, before adding Attachments or Equipment to Poles, secure and continuously carry with insurers having an A.M. Best Insurance Reports rating of A-:VII or better the following insurance Coverage:

- a. Workers' Compensation. Licensee must comply with all statutory Workers' Compensation Laws in the state of operation.
- b. Employers' Liability. Insurance with a limit of \$1,000,000 each accident, \$1,000,000 by disease-each employee, and \$1,000,000 by disease-policy limit and will furnish proof thereof satisfactory to Rocky Mountain Power prior to commencing work.



- c. Commercial General Liability. Licensee must maintain commercial general liability insurance on the most recently approved ISO policy form, or its equivalent, written on an occurrence basis, with minimum limits of \$5,000,000 each occurrence for bodily injury and property damage and \$5,000,000 general aggregate including the following coverages:
  - a. Premises and operations coverage
  - b. Independent contractor's coverage
  - c. Contractual liability
- d. Commercial Automobile Liability. Licensee must maintain commercial automobile liability insurance on the most recently approved ISO policy, or its equivalent, with a minimum combined single limit of \$5,000,000 each accident for bodily injury and property damage covering all owned, hired or non-owned vehicles, assigned to or used in the performance of the work.
- e. Umbrella Liability. Licensee must maintain umbrella or excess liability insurance with minimum limits of \$5,000,000 each occurrence/\$5,000,000 aggregate, providing coverage in excess of the primary coverages and limits in the Employer's Liability insurance, Commercial General Liability insurance and Commercial Automobile Liability insurance above.

Rocky Mountain Power does not represent that the insurance coverages specified herein (whether in scope or amounts of coverage) are adequate to protect the obligations of the Licensee, and Licensee solely responsible for any deficiencies thereof.

#### Section 7.02 Additional Insurance Requirements

Except for workers' compensation, the policies required herein shall include provisions or endorsements naming Rocky Mountain Power, its parent, divisions, affiliates, subsidiary companies, co-lessees, co-venturers, officers, directors, agents, employees, servants and insurers as an additional insureds or loss payees, as applicable to specific insurance coverage. The commercial general liability additional insured endorsement shall be ISO Form CG 20 10 and ISO Form CG 20 37, or their equivalents.

To the extent of Licensee's negligent acts or omissions, all policies required by this Agreement shall include: (i) provisions that such insurance is primary insurance with respect to the interests of Rocky Mountain Power and that any other insurance maintained by Rocky Mountain Power (including self-insurance) is excess and not contributory insurance with the insurance required hereunder; and (ii) provisions that the policy contain a cross liability or severability of interest clause or endorsement in the commercial general liability and commercial automobile liability coverage. Unless prohibited by applicable law, all required insurance policies shall contain provisions that the insurer will have no right of recovery or subrogation against Rocky Mountain Power, its parent, divisions, affiliates, subsidiary companies, co-lessees or co-venturers, agents, directors, officers, employees, servants, and insurers, it being the intention of the Parties that the insurance as effected shall protect all of the above-referenced entities evidenced by waiver of subrogation wording.

A certificate of insurance shall be furnished to Rocky Mountain Power confirming the issuance of such insurance prior to installation of Equipment by Licensee. Lack of notification shall be considered a material breach of this Agreement. Upon receipt of notice from its insurer, Licensee shall endeavor to provide Rocky Mountain Power with thirty (30) days prior written notice of cancellation.

Licensee shall require Subcontractors who perform work to carry liability insurance (auto, commercial general liability and excess) and workers' compensation/employer's liability insurance commensurate with their respective scopes of work. Licensee shall remain responsible for any claims, lawsuits, losses and expenses including defense costs that exceed any of its Subcontractors' insurance limits or for uninsured claims or losses.

#### Section 7.02      Security

Licensee must furnish and maintain Security at all times during the term of this Agreement. The face amount of the Security will be based on (a) the total number of Estimated Attachments; or (b) the total number of Licensee's actual Attachments, if greater than Estimated Attachments, as further described below. Such Security must be furnished upon execution of this Agreement and be maintained in full force and effect throughout the term of this Agreement, including any renewals thereof, except as otherwise agreed to by the Parties. The furnishing of Security will not relieve Licensee of any of its obligations under this Agreement, and Security will not be released until all of Licensee's obligations under this Agreement have been discharged. The initial required Security will be \$65,000 and may be reviewed and reasonably adjusted annually by Rocky Mountain Power. Rocky Mountain Power may draw upon such Security to satisfy Licensee's obligations under this Agreement, and Licensee shall replenish such Security within sixty (60) days.

The amount of Security will be in an amount reasonably sufficient to pay Rocky Mountain Power for the cost to remove and dispose of Licensee Attachments and related Equipment, plus two (2) years' of rental payment obligations under this Agreement. The calculation of the cost to remove and dispose of Licensee's Attachments and related Equipment will be Rocky Mountain Power's current hourly wage rate of a four-person crew multiplied by the number of (a) Estimated Attachments; or (b) actual Attachments, if greater than Estimated Attachments.

## ARTICLE VIII. ERM, DEFAULT AND TERMINATION

### Section 8.01 Term and Termination

This Agreement shall be effective as of the date of execution by both Parties (“Effective Date”). The initial term shall be for five (5) years from the Effective Date. This Agreement shall automatically be extended for five (5) additional five (5) year terms unless either Party terminates it at the end of the then current term by giving the other Party written notice of the intent to terminate at least ninety (90) days prior to the end of the then current term. In addition, Licensee shall have the right to terminate this Agreement upon the annual anniversary of the Effective Date provided that ninety (90) days prior written notice is given to Rocky Mountain Power. Upon expiration or termination of this Agreement for any reason (including termination for default), Licensee must remove its Attachments and Equipment from Poles within the ninety (90) day notice period. If Licensee fails to remove its Attachments and Equipment within the ninety (90) day period, Rocky Mountain Power may remove and dispose of Licensee’s Attachments and Equipment at Licensee’s sole risk and expense. On the date of termination, all rights and privileges of Licensee under this Agreement will cease; however neither Licensee nor Rocky Mountain Power will be released from any liability under this Agreement which may have arisen or accrued during the term of this Agreement or otherwise survives the termination or expiration of this Agreement.

### Section 8.02 Default

The following constitutes a default under this Agreement if not cured within thirty (30) days following written notice of the nature of the default: (a) any material breach of this Agreement; (b) the appointment of a receiver to take possession of all of the assets of Licensee; (c) a general assignment for benefit of creditors; (d) any action taken or suffered by Licensee under any insolvency or bankruptcy act.

### Section 8.03 Notice of Default/Cure Period

Rocky Mountain Power and Licensee will provide written notice of the default to the other party and the other party must cure the default within thirty (30) days from receipt of notice of default.

### Section 8.04 Remedies for Default

Rocky Mountain Power may utilize any and all remedies available to it at law and in equity in the event the Licensee fails to cure a default within the cure period set forth above. Such remedies may include, without limitation: (a) refusal to authorize any additional Attachments until the default is cured; (b) termination, in whole or in part, of this Agreement; and (c) cure the default at Licensee’s sole cost and expense.

Licensee may use any and all remedies available to it at law and equity if Rocky Mountain Power fails to cure a default within the applicable cure period set forth above. Such remedies may include, without limitation: (a) termination, in whole or in part, of this Agreement; and (b) cure the default at Rocky Mountain Power’s sole cost and expense.

## Article IX. GENERAL PROVISIONS

### Section 9.01 Confidentiality

Licensee agrees to keep strictly confidential the terms of this Agreement, and not to disclose the same except: (a) to its employees, agents and representatives to the extent necessary to perform its obligations under this Agreement, (b) to the extent required by law or the rules of any regulatory agency, or (c) if compelled by order of any court or governmental agency of competent jurisdiction, provided that with respect to (b) and (c) above, Licensee gives Rocky Mountain Power prompt prior written notice of any disclosure request, application for court order, court order or other governmental process, before making any disclosure and gives Rocky Mountain Power an opportunity to object to and seek to prevent or omit such disclosure.

### Section 9.02 Entire Agreement

This Agreement constitutes the entire Agreement of the Parties for Small Cell and Wi-Fi Attachments and supersedes any existing agreements for Small Cell and Wi-Fi Attachments but does not supersede existing agreements between the Parties for attachments under existing agreements for macro cell, street light only poles or wireline Attachments. Any amendments to this Agreement must be in writing and signed by the Parties.

### Section 9.03 Choice of Law/Venue

This Agreement and performance under this Agreement will be construed, interpreted, regulated and enforced under the laws of Utah. The state and federal courts within Salt Lake County, Utah will be the sole proper venue for resolution of disputes under this Agreement and the Parties agree to submit to such jurisdiction.

### Section 9.04 Changes in Law

The Parties agree to negotiate in good faith any changes to this Agreement necessitated to conform to applicable law.

### Section 9.05 Severability

If any provision or part of this Agreement is or becomes invalid under any applicable statute, regulation, or law and such invalidity does not materially alter the essence of this Agreement with respect to either Party, the invalidity shall not render this entire Agreement unenforceable and such provision or part shall be deemed void.

### Section 9.06 Encumbrances

Licensee must prevent any and all liens or other encumbrances from attaching to Rocky Mountain Power's property as a result of Licensee's activities under this Agreement.

### Section 9.07 Headings and Exhibits

The captions and headings used in this Agreement are for convenience in reference only and not for interpretation purposes. All exhibits referred to herein and recitals are incorporated by reference.

Section 9.08      Force Majeure

Except for the payment of monies due under this Agreement, neither Party shall be deemed in default under this Agreement to the extent that any delay or failure in the performance of its obligations is caused by an event of Force Majeure, including acts of the United States of America or any state, territory or political subdivision thereof, acts of God or a public enemy, fire, flood, freight embargos, civil disturbances or any other cause beyond the reasonable control of the Party claiming Force Majeure. The Party claiming Force Majeure must provide prompt written notice to the other Party and will immediately commence cure and so notify the other Party after it is reasonably practicable to do so.

Section 9.09      Assignments

Licensee must not voluntarily or involuntarily assign, transfer, sublease or sublet this Agreement, in whole or in part, or any right, privilege or obligation under this Agreement, without Rocky Mountain Power's prior written consent, at which time Rocky Mountain Power may require that the proposed assignee or successor enter into a new agreement or other reasonable conditions. Approval of assignment may require Application to remove from each Pole by the assignor and an Application to attach to each Pole by assignee if the record of Attachments is in dispute. Notwithstanding anything to the contrary, Licensee may sell, assign or transfer this Agreement without any approval or consent of Rocky Mountain Power to Licensee's principal, affiliates, subsidiaries of its principal or to any entity which acquires all or substantially all of Licensee's assets in the market defined by the Federal Communications Commission in which the Property is located by reason of a merger, acquisition or other business reorganization provided that Licensee is not in default hereunder, and the assignee or transferee, in each case, (i) executes an agreement to be bound by the terms and conditions herein applicable to Licensee and to assume all liabilities related to then-existing conditions (including all non-conforming conditions) of the Attachments, in such form as is acceptable to Rocky Mountain Power; and (ii) delivers a replacement Security meeting the requirements of Section 7.03.

Section 9.10      Waiver

Failure by either Party to enforce any of the terms or provisions of this Agreement shall not be construed as a waiver hereunder.

Section 9.11      Time is of Essence

Time is of essence with respect to every term and provision of this Agreement.

Section 9.12      No Partnership

Nothing herein shall be construed to create a partnership, trust, joint venture, or association between the Parties.

Section 9.13      No Third-party Beneficiaries

This Agreement shall not be construed for the benefit of any third-party, including without limitation, customers of either Party.

Section 9.14      Attorneys' Fees

If either Party files any action or brings any proceeding against the other arising from or related to this Agreement, the prevailing Party will be entitled to recover, in addition to any judgment or

decree for costs, such reasonable attorneys' fees as it may have incurred in such suit, action, or other legal proceeding, together with other reasonable litigation expenses.

Section 9.15      Waiver of Jury Trial

TO THE FULLEST EXTENT PERMITTED BY LAW, EACH OF THE PARTIES HERETO WAIVES ANY RIGHT IT MAY HAVE TO A TRIAL BY JURY IN RESPECT OF LITIGATION DIRECTLY OR INDIRECTLY ARISING OUT OF, UNDER OR IN CONNECTION WITH THIS AGREEMENT. EACH PARTY FURTHER WAIVES ANY RIGHT TO CONSOLIDATE ANY ACTION IN WHICH A JURY TRIAL HAS BEEN WAIVED WITH ANY OTHER ACTION IN WHICH A JURY TRIAL CANNOT BE OR HAS NOT BEEN WAIVED.

Section 9.16      Agreement Notices

Any notice regarding this Agreement must be in writing, addressed to the Party to be notified as set forth below or at such other address as a Party may designate for itself from time to time by written notice, and be transmitted by United States mail, by regularly scheduled overnight delivery, electronic mail or by personal delivery:

Rocky Mountain Power:  
Joint Use Administration-Contracts  
825 NE Multnomah St., Suite 1700  
Portland, Oregon 97232  
[jointusecontracts@pacificorp.com](mailto:jointusecontracts@pacificorp.com)

Licensee:  
Wasatch Utah RSA No. 2 Limited Partnership  
d/b/a Verizon Wireless  
180 Washington Valley Road  
Bedminster, New Jersey 07921  
Attention: Network Real Estate  
[noc.support@one.verizon.com](mailto:noc.support@one.verizon.com)

Section 9.17      Operational Notice

All notices regarding permitting and other communications regarding day-to-day operations will be submitted by the Parties via ENS if designated by the Utah Commission or Rocky Mountain Power, or via e-mail at the addresses set forth below or at such other address as a Party may designate for itself from time to time by written notice.

Rocky Mountain Power:  
[jointuse@pacificorp.com](mailto:jointuse@pacificorp.com)

Licensee:

noc.support@one.verizon.com

In the case of emergency work, as prescribed in Section 3.19 each Party will notify the other Party via the emergency contact information set forth below in addition to the operational contact notice in writing.

Rocky Mountain Power:  
(888) 221-7070

Licensee:  
Network Operations Center (800) 264-6620

When an Emergency Condition arises under Section 4.05, Rocky Mountain Power will notify Licensee's contact below:

Licensee's 24 hour phone/cellphone number: (800) 264-6620  
Licensee's contact name (if appropriate): Network Operations Center  
Licensee's e-mail: noc.support@one.verizon.com

IN WITNESS WHEREOF, the Parties have caused this Agreement to be executed by their duly authorized officers as of the date first herein written.

LICENSEE  
WASATCH UTAH RSA NO. 2  
LIMITED PARTNERSHIP d/b/a  
VERIZON WIRELESS

PACIFICORP, doing business as  
ROCKY MOUNTAIN POWER

  
\_\_\_\_\_  
Signed  
**Steve LeVar**  
\_\_\_\_\_  
Printed  
Director Network Field Engineering  
\_\_\_\_\_  
Title  
2/26/2018  
\_\_\_\_\_  
Date Signed

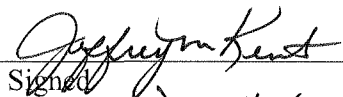
  
\_\_\_\_\_  
Signed  
Director Distribution Support  
\_\_\_\_\_  
Printed  
Jeffrey M. Kent  
\_\_\_\_\_  
Title  
3/13/2018  
\_\_\_\_\_  
Date Signed

**Exhibit A**

See attached Rocky Mountain Power Electric Service Schedule No. 4

**The remainder of this page is left intentionally blank**





---

ROCKY MOUNTAIN POWER  
ELECTRIC SERVICE SCHEDULE NO. 4

STATE OF UTAH

---

Pole Attachments

---

**AVAILABILITY:** To public utilities, wireless providers, cable television companies, communications companies, or other entities that provide information or telecommunications services or any other services whose operation requires that cables, wires, and other appurtenances be placed on Company utility poles. This Schedule shall be available only upon the following three conditions:

1. The execution of a Pole Attachment Agreement between an "attaching entity" as defined by Utah Admin. Code § R746-345-2 and the Company for permission to place equipment on the Company's poles; or, in the event that such an agreement has not been reached, the attaching entity is subject to the provisions of the standard Attachment Agreement approved by the Utah Public Service Commission ("Standard Agreement").
2. The approval by the Company of the attaching entity's application, as required under the agreement between the Company and the attaching entity, for permission to place equipment on Company poles.
3. The availability of utility poles located on the Company's interconnected system in the state of Utah, which are of sufficient size and capacity to accommodate the equipment to be installed in accordance with the National Electric Safety Code, the applicable pole attachment agreement and applicable Utah Administrative Code provisions.

**APPLICATION:** The rate specified in this Electric Service Schedule shall apply to all Company-owned poles.

(continued)



P.S.C.U. No. 50

First Revision of Sheet No. 4.2  
Canceling Original Sheet No. 4.2

---

**ELECTRIC SERVICE SCHEDULE NO. 4 - Continued**

**ANNUAL CHARGE:** For each Company pole on which the attaching entity has placed an attachment, \$5.76 per foot of space used by the attaching entity. "Space used" is determined under the provisions of Utah Admin. Code § R746-345-5.A.3.

**SCHEDULE OF NON-RECURRING FEES:** For each Company pole on which the attaching entity has placed or requests to place an attachment, the following fees may be applied.

**1. Per Pole Application Fee: \$55.64 per Pole**

This fee is applicable when Licensee's submit application for permission to attach to the Company's poles. This fee covers the expected costs for performing the work necessary to determine what make-ready work must be done to accommodate the application. The fee shall be based on a state specific allocation of costs.

**2. Unauthorized Attachment Charge: \$100.00 + Back Rent, per Pole**

This fee is applicable when the Company discovers a Licensee attachment on a Company pole where the Company has no record of approving the attachment. Back Rent shall consist of 5 years of rent at the current rental rate unless credible evidence supports a lesser period. The Unauthorized Attachment Fee shall be waived if Licensee presents credible evidence of any of the following: approval by and payment of rent to a putative pole owner; good faith belief of pole ownership; or of attaching in good faith. The Unauthorized Attachment Fee shall also be waived if Licensee presents credible evidence the attachment was in place prior to January 1, 2007.

**3. Other Miscellaneous Fees:** To be invoiced at the Company's actual cost. This fee is applicable to recover the cost of work necessitated by Licensee requests not otherwise recovered in the Annual Charge or other fee categories, such as actual or estimated charges for make-ready work and labor for emergency restoration work.

**TERMS, CONDITIONS, LIABILITIES:** The terms, conditions, and liabilities for service under this Schedule shall be those specified in the applicable pole attachment agreement between the Company and the attaching entity. The annual charge rate specified by the agreement shall be in accordance with the rate specified in this Schedule and shall be subject to periodic adjustment in accordance with the applicable agreement and the rules established by the Public Service Commission of Utah and subject to its approval.

**ELECTRIC SERVICE REGULATIONS:** Service under this Schedule will be in accordance with the terms of the Pole Attachment Agreement or the Standard Agreement between the Company and the attaching entity. The Electric Service Regulations of the Company on file with and approved by the Public Service Commission of Utah, including future applicable amendments, will be considered as forming a part of and incorporated in said Agreement. In case of any conflict between any of the provisions of the Pole Attachment Agreement or Standard Agreement, this Rate Schedule, and the Electric Service Regulations, the provisions of this Rate Schedule will take precedence followed by the provisions of the Pole Attachment Agreement or the Standard Agreement, whichever is applicable.

---

Issued by authority of Report and Order of the Public Service Commission of Utah in Advice No. 14-11

**FILED:** November 25, 2014

**EFFECTIVE:** December 25, 2014

**Exhibit B**

See attached Small Cell Antenna Installation Guidelines

**The remainder of this page is left intentionally blank**

# BHE DSG-JU-01—Small Cell Antenna Installation Guidelines

## 1. Scope

All small cell antenna installations must meet, at a minimum, the current applicable NESC standards, FCC, and FAA rules and regulations. The administrative authority may have additional requirements depending on the location of the installation. This guideline is intended to:

- Provide guidance on install locations on a distribution pole according to Federal Communications Commission (FCC) 11-50 and 47 U.S.C. (United States Code) 224
- Provide assistance to company personnel in evaluating correct installation of telecommunications equipment to avoid system operation problems
- Supplement published company distribution construction standards, policies, and procedures
- Implement common minimum practices throughout the company's service territory that comply with applicable codes, ordinances, and tariffs

## 2. Changes or Conflicts in Requirements

Where city, county, state, regulatory agency, or other administrative authority requirements exceed the company's requirements, the more stringent requirements shall apply.

Exceptions to the requirements shall not be permitted except when physical restrictions make compliance impractical, when required by an administrative authority, or where all parties involved are in agreement.

Depending on the local operating and weather conditions, deviations from this guideline may be required as determined by local engineering and operations. It is incumbent on those performing the design and site work to fully understand the requirements necessary to complete the installation safely and in compliance with federal, state, and local regulations.

## 3. Definitions and Acronyms

### 3.1. Definitions

**Administrative Authority:** The governmental authority exercising jurisdiction over the installation.

**Company:** Refers to MidAmerican Energy, NV Energy (NV Energy North and NV Energy South), PacifiCorp (Pacific Power and Rocky Mountain Power), and other subsidiaries of Berkshire Hathaway Energy providing electric supply services in the United States.

**Small Cell:** Types of small cells include femtocells, picocells and microcells – broadly increasing in size from femtocells (the smallest) to microcells (the largest). Any or all of these small cells can be based on 'femtocell technology' – i.e. the collection of standards, software, open interfaces, chips, and know-how that have powered the growth of femtocells. 'Small cell' is an umbrella term for operator-controlled, low-powered radio access nodes, including those that operate in licensed spectrum and unlicensed carrier-grade Wi-Fi. Small cells typically have a range from 10 meters to several hundred meters.

**Note:** This definition of small cell is derived from the Small Cell Forum, <http://www.smallcellforum.org/>.

### 3.2. Acronyms

**FAA:** Federal Aviation Administration  
**FCC:** Federal Communications Commission  
**NEC:** National Electrical Code  
**NESC:** National Electrical Safety Code  
**OSHA:** Occupational Safety and Health Administration

## 4. Coordination Between the Company and the Telecommunications Company

Close coordination will be necessary with the telecommunications company to complete the installation. In addition, company personnel use terminology unfamiliar to the communications industry; be aware of the resulting gap in understanding. This guideline may be shared with the telecommunications company prior to designing the installation so that the telecommunications company may be aware of the company's basic requirements.

## 5. Supplemental Information

This guideline is not considered all-inclusive. The company may have additional installation requirements. In addition, the administrative authority responsible for approving specific installations may have additional requirements not covered by this guideline.

The company's joint use department may provide assistance with the application process.

## 6. Pole Selection Criteria

Installation of communications equipment is limited to poles carrying electrical distribution facilities only with voltage level of 34.5 kV and below. The selected distribution pole is not encumbered by electrical equipment that includes, but is not limited to, an air break switch, transformers, capacitor banks, regulators, reclosers, down guys, or risers. Installation of communication equipment on distribution poles are at the sole discretion of the company. The priority of selection of appropriate pole candidates for small cell antenna attachments is as follows (in order of preference):

### 6.1. Secondary or Service Pole (with or without Streetlight)

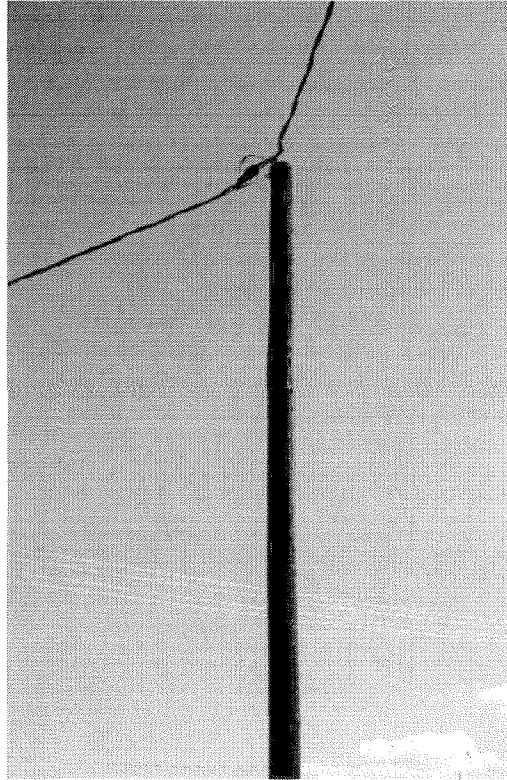

**Figure 1—Secondary/Service Pole, Example**

## 6.2. Single-Phase Primary Pole

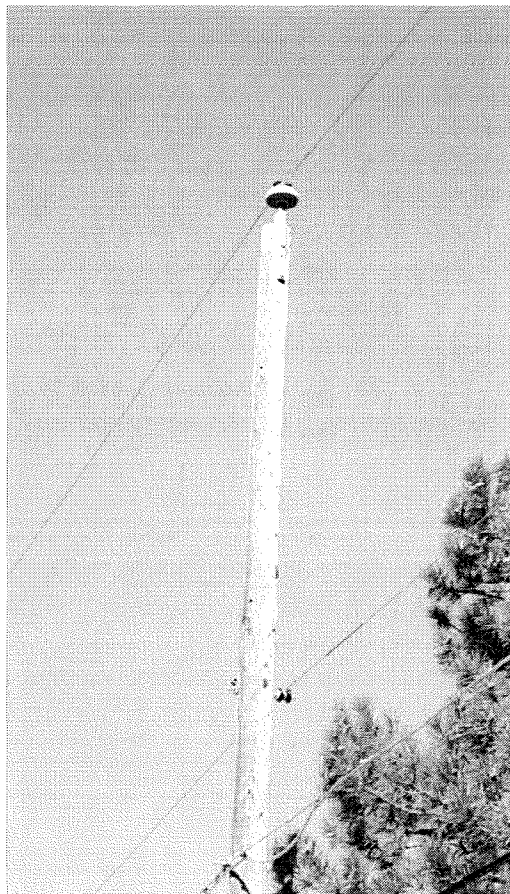

**Figure 2—Single-Phase Primary Pole, Example**

**Design Guide**

BHE DSG-JU-01—Small Cell Antenna Installation Guidelines

Published Date: 25 Aug 17

Last Reviewed: 25 Aug 17

### 6.3. Two-Phase Primary Pole

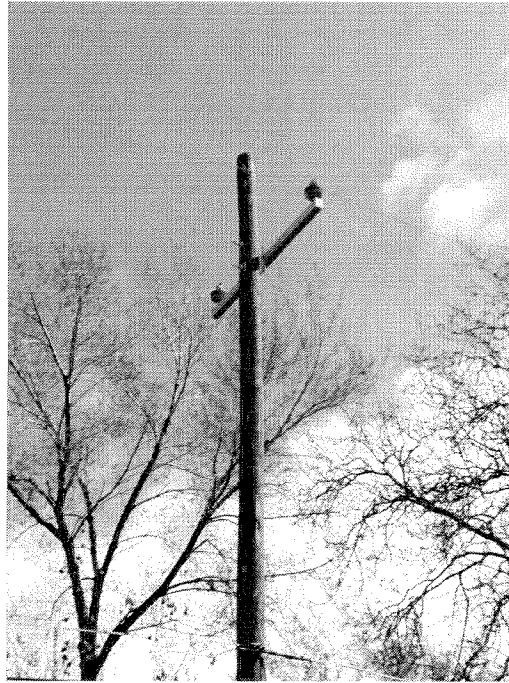

**Figure 3—Two-Phase Primary Pole, Example**



## 6.4. Three-Phase Primary Pole

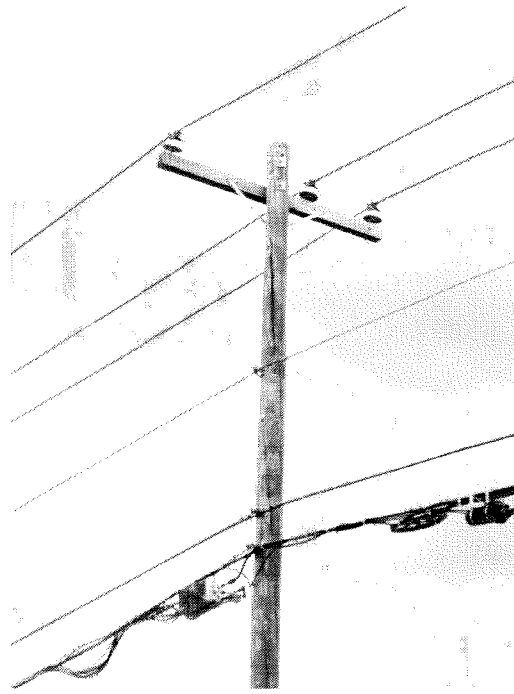

**Figure 4—Three-Phase Primary Pole, Example**

**Design Guide**

BHE DSG-JU-01—Small Cell Antenna Installation Guidelines

Published Date: 25 Aug 17

Last Reviewed: 25 Aug 17

Page 6 of 12



*Printed versions of this specification may be out of date. Please consult the online specifications for the most recent version. This document shall be used and duplicated only in support of Berkshire Hathaway Energy projects. ©2017 by PacifiCorp.*

## 7. General Installation Requirements

The following covers the basic installation requirements for small cell antenna attachments. This list may not include all requirements needed for installation:

- Only one antenna array attachment installed per pole.
- Installation is on a “clean” pole. The pole is not encumbered by an air break switch, transformers, capacitor banks, regulators, reclosers, down guys, risers, or other electrical equipment.
- Distribution facilities are nearby for providing electrical service.
- All work is performed by an authorized qualified worker if the installation is in the supply space.
- Power outages needed for equipment installation must be coordinated with the company.
- Zoning, clearance, building permit, easements, and other required permits or approvals by the administrative authority are obtained by the telecommunications company.
- The company retains the right to remove the antenna equipment if requested by the administrative authority.
- The telecommunications company shall perform a TOWAIR (or Landing Slope Facility Calculator) study. The study shall be provided to the company to be filed with the FAA. If the FAA requires the structure to be registered, an Antenna Structure Registration number must be obtained from the FCC. The telecommunications company is responsible for all FAA requirements.
- The telecommunications company shall provide estimated electrical load information of the installation to the company.
- Antenna array wind loading information is provided to the company. A separate pole loading calculation study may be required to be submitted by the telecommunications company.
- A disconnect switch on the electrical service to the installed antenna system is provided by the telecommunications company to de-energized the entire antenna system.
- The telecommunications company must notify the surrounding residents and landowners when the pole modifications will be made.
- The telecommunications equipment owner shall incur the cost of removing the equipment from a pole in the event that the equipment is abandoned.
- The telecommunications company must notify the company at least 45 days in advance when an outage will be required to service an installed antenna.

## 8. Antenna Locations

Figure 5 depicts the possible installation locations of small cell antenna array on a distribution pole. No antennas shall be installed if existing electrical equipment is installed on the pole:

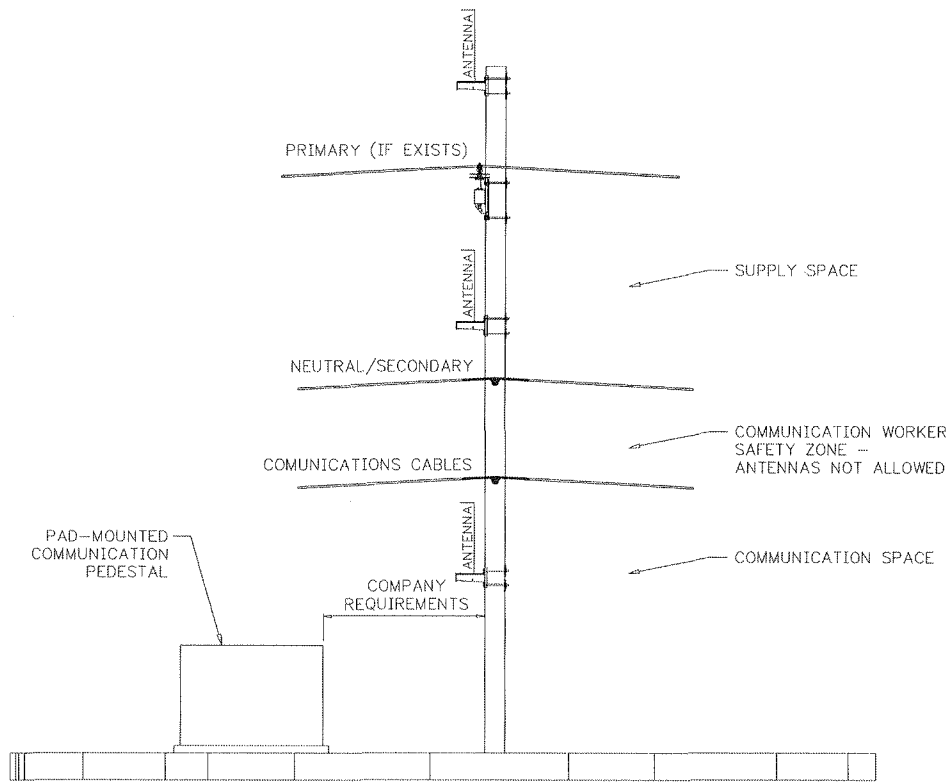

**Figure 5—Possible Antenna Locations on Distribution Pole**

### 8.1. Supply Space

Antenna installation above the communications worker safety zone is considered to be an installation in the supply space. All work in this space must be done by an authorized qualified worker in accordance with NESC and OSHA rules.

Pole-top extensions may not be used to extend the height of the pole for antenna array installation.

### 8.2. Communication Space

Antenna installations within the communications space shall be performed by a qualified communications worker.

### 8.3. Communications Worker Safety Zone

No antennas or equipment shall be installed within the communications worker safety zone per NESC rules.

**Design Guide**

BHE DSG-JU-01—Small Cell Antenna Installation Guidelines

Published Date: 25 Aug 17

Last Reviewed: 25 Aug 17

## 9. Additional Equipment Requirements

### 9.1. Communication Pedestal

The company requires that all additional equipment associated with the antenna system not critical to the antenna signal transmission be installed in a pad-mounted communication pedestal as illustrated in Figure 5. Other equipment critical to antenna transmission maybe installed on the pole at the discretion of the company. This pedestal is located at a distance specified by the company to ensure it does not block access to the pole. Conduits shall run underground between the pole and the pedestal.

The disconnect switch to completely de-energize the antenna system and metering equipment, if applicable, for the electrical service shall also be housed in this pedestal.

### 9.2. Grounding

The telecommunications company must install their own NEC-approved ground and bond it to the company's ground. If a ground is not available on the pole, the telecommunications company must request the company install a ground.

The telecommunications company is responsible for providing adequate lightning and over/under voltage protection to protect their antenna system from damage due to system voltage variations.

## 10. Climability

### 10.1. Climbing Space

All communications equipment on the distribution pole must be installed in a manner that maintains climbing space according to the NESC. The antenna installation must not impede the climbing space on the pole.

### 10.2. Bracket

Standoff brackets must provide at least 4.5 inches of clear space from the surface of the pole.

The company prefers all additional antenna equipment be installed in the communication pedestal. If it is necessary to install an additional communications equipment cabinet on the pole, it must be mounted on the pole using a standoff bracket if the height of the equipment is over 12 inches. The allowable size of the cabinet will be limited based on its total wind loading. Any communications equipment exceeding the maximum wind loading of the pole shall be installed in the communication pedestal. Only one communications equipment cabinet may be installed on the pole.

### 10.3. Conduit

All conduits on the pole must not interfere with a lineman's ability to safely climb the pole. Conduits less than two inches in diameter may be banded to the pole. Conduits must be mounted on standoff brackets in instances where a conduit is larger than two inches in diameter, or where there are more than two conduits.

Where a single-phase primary dip is already on the pole, the communications conduit standoffs shall be mounted jointly with the company.

All communications conduit entering the supply space must be non-conductive per NESC. All metallic conduit outside of the utility space installed on a pole must be bonded to the pole ground.

### 10.4. Steel Poles

If a steel pole is used for an antenna attachment, communication cables need to be routed inside the steel pole. There may be additional requirements specified by the company for this pole configuration.

## 11. Radio Frequency

The telecommunications company shall affix a sign near the base of the pole reading "High Energy Field – RF Monitors Must Be Worn." If the disconnect switch is installed on the pole, this sign shall be affixed near the disconnect switch equipment box.

The installation must be in compliance with the FCC Office of Engineering and Technology (OET) Bulletin 65, "Evaluating Compliance with FCC Guidelines for Human Exposure to Radiofrequency Electromagnetic Fields."

## 12. Drawings

The telecommunications company shall provide drawings for the proposed small cell antenna attachment installation. The drawings should not be conceptual drawings, but location specific and complete for the proposed installation. Drawings shall include, at a minimum, but not be limited to:

1. Pole location (address, area map)
2. Pole photos
3. Customer-owned conduit, wire, cable, and service route details (for underground service)
4. Existing and proposed clearances on the structure
5. Down guys where required
6. Equipment cabinet sizes and mounting locations
7. Metering and electric service facilities and its proposed locations
8. Antenna array size
9. Wind loading information
10. Pole loading calculation study (if required)
11. Estimated electrical load for all equipment

## 13. Design Guide Issuing Department

The engineering standards and technical services department of the company published this document. Questions regarding editing, revision history and document output may be directed to the lead editor at [eampub@pacificorp.com](mailto:eampub@pacificorp.com). Technical questions and comments may be directed to joint use or distribution standards engineering. This design guide shall be used and duplicated only in support of company projects.

This page is left blank intentionally.

**Design Guide**

BHE DSG-JU-01—Small Cell Antenna Installation Guidelines

Published Date: 25 Aug 17

Last Reviewed: 25 Aug 17

Page 12 of 12



**Exhibit C**

**Wi-Fi Antenna Installation Guidelines**

**The remainder of this page is intentionally blank**



## 2U.2—Wi-Fi Antenna Installation Guidelines

### 1 Scope

This document covers the installation of wi-fi type antennas on distribution and streetlight poles. The guidelines contained herein are intended to avoid operational problems and to ensure installations comply with existing laws and regulations. This guide is not considered to be all-inclusive. Depending on the local operating and weather conditions, deviations from this document may be required as determined by local operations staff.

### 2 Special Conditions

Any attachment to supply-line or fiber systems where a wireless terminal is attached in the supply space and a tail or lead traverses the distance from the supply space into the communication space of the attached structure is prohibited. If the wireless device must connect to supply-line or fiber systems in the communications space, it shall be installed on a separate structure unless the wireless device is also permitted in the communication space.

### 3 Coordination between PacifiCorp and the Attaching Entity

Close coordination with the attaching entity will be necessary to complete the installation. This guideline may be shared with the attaching entity prior to designing the installation so that they may be aware of PacifiCorp's basic requirements. Following are detailed requirements for attachments to PacifiCorp poles. For a checklist of deliverables due to the PacifiCorp Joint Use department, see Section NO TAG.

#### 3.1 Attachment agreement

Entities wishing to install any equipment on PacifiCorp's poles shall have a signed Attachment Agreement in effect prior to making application for attachment. If such an agreement is not currently executed, please contact PacifiCorp's Joint Use department to arrange one.

#### 3.2 Making an Application

All requests from any attaching entity wishing to install a wi-fi antenna on any PacifiCorp facility shall be sent to the PacifiCorp Joint Use department in Portland, Oregon. Prior to installing any equipment on PacifiCorp's pole, the attaching entity shall make application and receive written approval from PacifiCorp to attach the antenna. PacifiCorp may accept a proposed location, require changes to allow the installation at the attaching entity's expense, or decline the proposed location.

No installation shall commence until written approval is given from PacifiCorp's Joint Use department. The request shall identify the applicant, the installation contractor, the

address of the pole, the facility point number (from the pole tag) if present, and a photograph of the upper portion of the pole or streetlight, including the surrounding wires and aerial space. In addition, the following information is required:

### **3.2.1 Wi-Fi Antenna Information**

Requester shall provide PacifiCorp a copy of the wi-fi antenna's physical and electrical information. This document shall have information on radio frequency (RF) exposure from the wi-fi antenna. The antenna's RF shall be in accordance with the Federal Communications Commission (FCC) regulations regarding RF exposure from antennas to workers. Also, requester shall clearly and conspicuously post signs indicating:

- Safe working distance (approach distances) from the device; and
- Contact information for field workers, including information for temporary disabling of antenna at the site.

### **3.2.2 Electrical Load Information**

Requester shall supply information for electrical connection, such as demand in kW, voltage required, and method of connection to source. PacifiCorp is not responsible for possible poor performance of the electrical supply due to incorrect information provided by the customer.

### **3.2.3 Physical Information for Devices**

Requester shall provide physical dimensions for the device and antennae as well as weight information. A typical installation drawing or photo shall be submitted which demonstrates that the antenna is designed so as not to experience wind loading of more than four pounds per square foot based on 40 MPH wind.

## **3.3 Zoning and Permits**

Requester is wholly responsible for obtaining all government-required permits and approvals. Furthermore, requester is responsible for removing the equipment if requested by the local authority.

## **3.4 Removal cost**

The equipment owner shall incur all costs of removing the equipment from a pole in the event that the equipment is abandoned or no longer in service.

# **4 General Installation Requirements**

This section identifies the basic requirements for a wi-fi antenna installation on a distribution or streetlight pole. For further detail on installation requirements, see the PacifiCorp Distribution Construction Standards, *EU—Joint Use*.

#### 4.1 Installation on Streetlight-Only Poles

Antennas may be installed on streetlight-only poles without any utility primary wires or Joint Use attachments, provided the installation does not interfere with maintenance of the structure or streetlight.

All installations shall be made and maintained in compliance with the current National Electrical Safety Code (NESC), or if in California, General Order 95 (GO 95).

No additional devices are allowed on the pole without prior approval from the PacifiCorp Joint Use department.

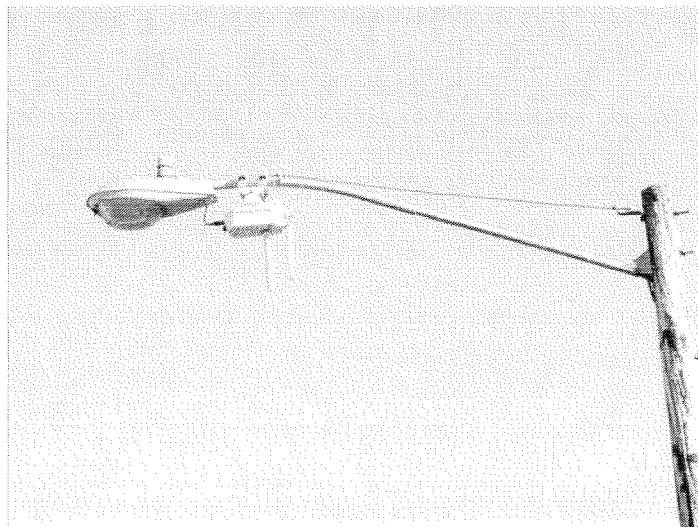

Figure 1—Typical Wi-Fi Antenna Installation on Streetlight Pole

#### 4.2 Installation on Distribution Poles

Antennas may be installed on primary and/or secondary distribution poles, either: 1) on the streetlight mast, provided the streetlight is located in the power supply space, or 2) on the pole in the communication space, using extension arm or crossarm construction, provided material and strength specifications are suitable and approved for such installations.

All installations shall be made and maintained in compliance with the current NESC, or if in California, GO 95.

No additional devices are allowed on the pole without prior approval from the PacifiCorp Joint Use department

The following figures illustrate proper antenna installation on distribution poles.

Antenna shall be installed by qualified workers on streetlights located in the power supply space.

Clearance in any direction will be based on rule 235I, table 235-6, row 1b (3" to neutral, 3" to secondary, and 6" plus 0.4" per KV in access of 8.7 KV line to line primary voltage).

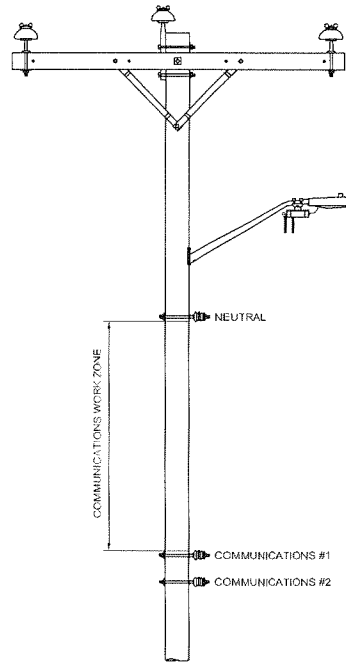

Figure 2—Antenna Installed in Power Supply Space

No antenna shall be attached to streetlights located in the communication worker safety zone, as described in rules 235C4 and 238E of NESC.

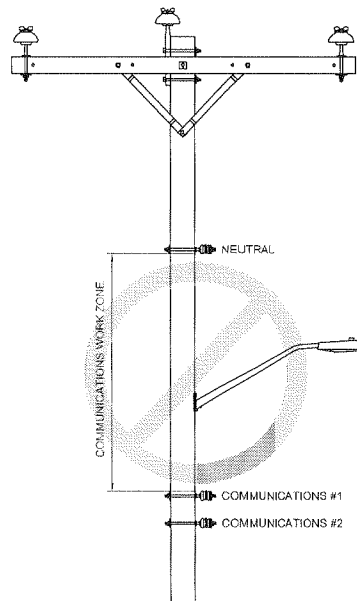

Figure 3—No Antennas on Streetlights in Communication Worker Safety Zone

Antenna may be installed in the communication space if attached to the pole. Antennas may not be installed on light fixtures located in the communication space

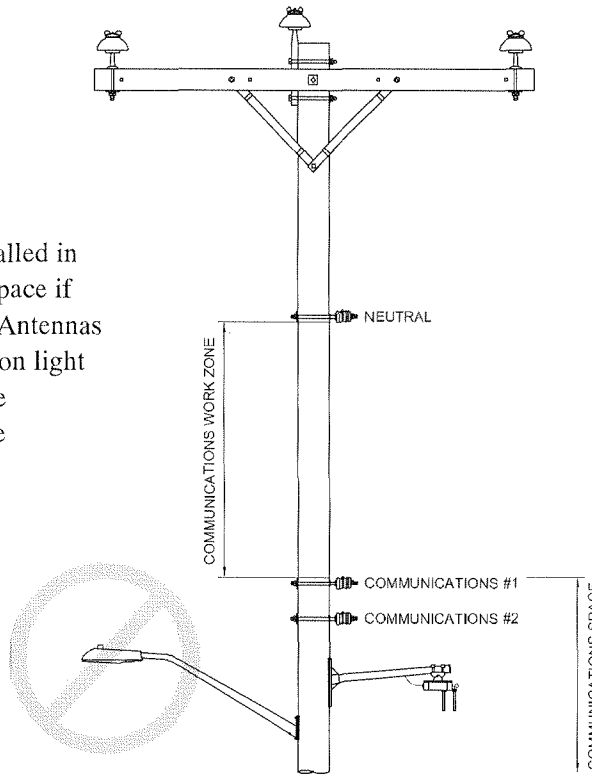

Figure 4—Antenna Installed on Pole in Communication Space

Installations shall not impede the climbing space on the pole. The climbing space is intended to provide adequate clearances on the pole for safe ascent and descent by the crew. The climbing space must extend 40" (48" in California) above and below the communication circuit.

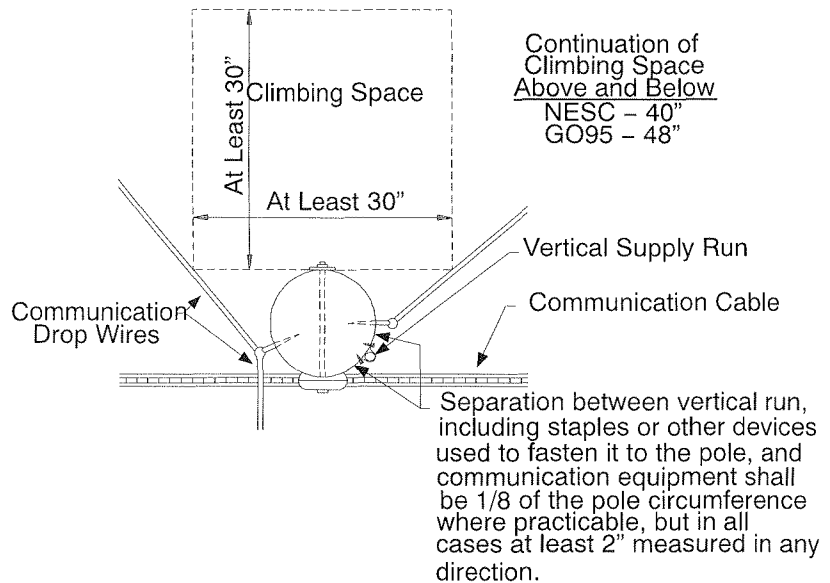

Figure 5—Climbing Space

## 5 Code requirements

### 5.1 Compliance with safety codes and rules

All attachments and work performed shall meet or exceed the requirements of the latest edition of the NESC (for example, rules 224A, 230C, 235C, 235I, 236, 238B, 238E, 239H, Section 42, Section 44 and 420Q); the Occupational Safety and Health Administration (rules 1910.268, 1910.097); applicable bulletins (FCC Bulletin 65 & IEEE C95.1, published in 1999); and the rules of any state agencies having jurisdiction.

### 5.2 Climbing Space

All facilities shall be installed in a manner that maintains adequate climbing space. The NESC defines the climbing space as a series of boxes 30 inches wide by 30 inches deep extending up the pole. See Figure 5 for more details.

### 5.3 Clearances

Local operations personnel may require a greater clearance distance to ensure that the approach distance is not compromised.

The following provides the minimum clearance from any part of the antenna to other equipment on the pole or ground surfaces. Refer to the latest copy of the NESC for other requirements or further detail:

1. Over the roadway, clearances shall exceed 16 feet.
2. Over driveways, parking lots, and alleys, clearances shall exceed 16 feet.
3. Over the pedestrian walkway, clearances shall exceed 12 feet.
4. Clearance to any supply wire shall be at least 48 inches.
5. Clearance to any other communications wire or equipment shall be 2 feet or more.
6. Horizontal clearance to pole surface shall be at least 2 feet.
7. The climbing space shall not be obstructed (see PacifiCorp Construction Standards *EU—Joint Use*).
8. Any antenna in the supply space shall be installed and maintained by workers authorized and qualified to work in the supply space.
9. All antennas shall be installed so as not to obstruct traffic control devices, signs, or vehicle sight lines.
10. No attachment method shall promote rust or decay of any kind to the pole or structure.
11. Some streetlights may have a wind rod attached above the arm. The wind rod must be considered part of the bracket-carrying luminaries as discussed in NESC rule 238C; therefore, clearances must be measured from this rod.

## 6 Checklist for Wi-Fi Attachments to PacifiCorp Facilities

Prior to attaching wi-fi devices to PacifiCorp facilities, the following must be provided to PacifiCorp's Joint Use department:

- Attachment Contract executed with PacifiCorp.
- All installation locations, including:
  - Pole number (from PacifiCorp pole plate);
  - Height of attachment;
  - Direction of any antennae (if applicable);
  - Address; and
  - Photographs of the top section of each pole showing streetlight and all attached wires/equipment.
- Employer's statement regarding qualification of employees performing installation (for installations in the supply space).
- Physical and electrical information, including:
  - Dimensions of device and antennae;
  - Weight;
  - Method of connecting to power source (e.g., photocell socket, etc.);
  - Maximum electrical demand in kW;
  - Voltage desired; and
  - Statement on size of RF field and worker-exposure limitations (include safe working distances and maximum exposure durations).
- Typical installation drawing or photo.
- Copies of applicable permits.

After PacifiCorp review:

- Corrections made either to the application or facilities in the field, if required by PacifiCorp.
- Receipt of Permit to Attach from PacifiCorp.

Post-Installation:

- Notification that installation is complete (to trigger post-installation inspection).
- Receipt of post-inspection results and required corrections.
- Receipt and payment of invoice for any billable work performed by PacifiCorp.

Maintenance:

- Any future pole attachments and/or equipment additions or replacements (where physical/electrical properties or location are altered) must be approved by the PacifiCorp Joint Use department.

## 7 Handbook Issuing Department

The Standards Engineering Documentation Department of PacifiCorp is responsible for issuing this document. Comments and suggestions are welcome. Additional copies may be obtained from:

Standards Engineering Documentation, Lloyd Center Tower  
825 NE Multnomah St., Suite 1600, Portland, Oregon 97232  
Telephone: (503) 813-5293 Fax: (503) 813-6804

Technical questions regarding the content of this document may be directed to PacifiCorp Standards Engineering, (503) 813-6883. Publication and use of this document is authorized by the Manager of Standards Engineering when the block below has been signed.

Approved:   
Dave Asgharian  
Standards Engineering

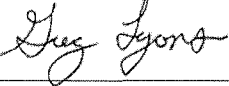
Approved:   
Greg Lyons, Manager  
Standards Engineering and Technology Development



**Exhibit D**

**Sample Application**

**The remainder of this page is intentionally blank**



**CERTIFICATE OF SERVICE**

Docket No. 18-035-14

I hereby certify that on April 24, 2018, a true and correct copy of the foregoing was served by electronic mail to the following:

**Utah Office of Consumer Services**

Cheryl Murray [cmurray@utah.gov](mailto:cmurray@utah.gov)

Michele Beck [mbeck@utah.gov](mailto:mbeck@utah.gov)

**Division of Public Utilities**

Christopher Parker [chrisparker@utah.gov](mailto:chrisparker@utah.gov)

William Powell [wpowell@utah.gov](mailto:wpowell@utah.gov)

Erika Tedder [etedder@utah.gov](mailto:etedder@utah.gov)

**Assistant Attorney General**

Patricia Schmid [pschmid@agutah.gov](mailto:pschmid@agutah.gov)

Justin Jetter [jjetter@agutah.gov](mailto:jjetter@agutah.gov)

Robert Moore [rmoore@agutah.gov](mailto:rmoore@agutah.gov)

Steven Snarr [stevensnarr@agutah.gov](mailto:stevensnarr@agutah.gov)

**Rocky Mountain Power**

Data Request Response Center [datarequest@pacificorp.com](mailto:datarequest@pacificorp.com)

Jana Saba [jana.saba@pacificorp.com](mailto:jana.saba@pacificorp.com)

[utahdockets@pacificorp.com](mailto:utahdockets@pacificorp.com)

Daniel Solander [daniel.solander@pacificorp.com](mailto:daniel.solander@pacificorp.com)

  
Jennifer Angell  
Supervisor, Regulatory Operations