

August 15, 2013

The Honorable Kimberly D. Bose
Secretary
Federal Energy Regulatory Commission
888 Second Street, N.E.
Washington, DC 20426

RE: *PacifiCorp*
Docket No. ER13-____-000

Dear Secretary Bose:

Pursuant to Section 205 of the Federal Power Act, 16 U.S.C. § 824d (2006), Part 35 of the Federal Energy Regulatory Commission's ("Commission") regulations, 18 C.F.R. Part 35 (2012), and Order No. 714¹ regarding electronic filing of tariff submittals, PacifiCorp hereby tenders for filing the following jurisdictional agreement:

- Memorandum of Understanding for Operation of a Common Metered Tie Point ("MOU Agreement"), dated August 6, 2013, between PacifiCorp and the Salt River Project Agricultural Improvement and Power District, ("SRP"), to be designated as PacifiCorp Rate Schedule No. 698.

1. Background and Reason for Filing

On August 6, 2013, SRP and PacifiCorp entered into the MOU Agreement. It sets forth the operational roles and responsibilities between the parties. It specifies metering, data and communication arrangements associated with the Cove Fort generation facility, as related to the common metered tie point. Accordingly, PacifiCorp respectfully requests that the Commission accept the MOU Agreement, attached hereto, for filing.

2. Effective Date and Request for Waiver

In accordance with 18 C.F.R. § 35.3(a)(1), PacifiCorp respectfully requests that the Commission establish an effective date of October 15, 2013 for the MOU Agreement.

¹ *Electronic Tariff Filings*, Order No. 714, 124 FERC ¶ 61,270 (2008).

To the extent that any filing requirement in Part 35 of the Commission's regulations is not satisfied by this filing and the materials enclosed herewith, PacifiCorp respectfully requests waiver of such requirements.

3. Designation

PacifiCorp respectfully requests that the MOU Agreement attached herewith be designated as PacifiCorp Rate Schedule No. 698.

4. Enclosures

The following enclosures are attached hereto:

Enclosure 1 MOU Agreement between SRP and PacifiCorp, to be designated as PacifiCorp Rate Schedule No. 698

5. Communications

All communications and correspondence regarding this filing should be forwarded to the following persons:

Patrick C. Cannon
Senior Counsel
PacifiCorp
825 N.E. Multnomah, Suite 1800
Portland, OR 97232
(503) 813-5613
(503) 813-7252 (facsimile)
Patrick.Cannon@PacifiCorp.com

Rick Vail
Vice President, Transmission
PacifiCorp
825 N.E. Multnomah, Suite 1600
Portland, OR 97232
(503) 813- 6938
(503) 813- 6893 (facsimile)
Richard.Vail@PacifiCorp.com

6. Service List

Pursuant to Rule 2010 of the Commission's Rules of Practice and Procedure, a copy of this filing is being served on the following:

Salt River Project
Margaret Rostker, Esq.
MS 207
PO 52025
Phoenix, AZ 85072
Marostke@srpnet.com

Utah Public Service Commission
Heber M. Wells Building
160 East 300 South
Salt Lake City, UT 84114
psc@utah.gov

The Honorable Kimberly D. Bose
August 15, 2013
Page 3

If you have any questions, or if I can be of further assistance, please do not hesitate to contact me.

Respectfully Submitted,

/s/ Patrick C. Cannon
Patrick C. Cannon

Attorney for PacifiCorp

CERTIFICATE OF SERVICE

I hereby certify that I have on this day caused a copy of the foregoing document to be served via first-class mail or electronic mail upon each of the parties listed in the enclosed Service List.

Dated at Portland, Oregon this 15th day of August, 2013.

/s/ Patrick C. Cannon

Patrick C. Cannon
PacifiCorp
825 N.E. Multnomah, Suite 1800
Portland, OR 97232
(503) 813-5613
(503) 813-7252 (facsimile)
patrick.cannon@pacificorp.com

Memorandum of Understanding
For Operation of a Common Metered Tie Point
Between
Salt River Project Agricultural Improvement and Power District
And
PacifiCorp

This Memorandum of Understanding for Operation of a Common Metered Tie Point (“MOU”) sets forth the operational roles and responsibilities as between the Salt River Project Agricultural Improvement and Power District (“SRP”) and PacifiCorp. The MOU further specifies metering, data and communication arrangements associated with the Cove Fort generation facility, as related to the common metered tie point. SRP and PacifiCorp hereinafter may also be referred to individually as a “Party” and collectively as “Parties.”

WHEREAS:

- A.** Cove Fort generating facility (“Cove Fort”) is a planned 65 MW geothermal plant located in Beaver County, Utah, owned by Enel Green Power (“Enel”) and interconnected to the PacifiCorp transmission system.
- B.** Cove Fort is planned to be completed in two (2) phases, with Phase I built to generate 25 MW and Phase II planned for 40 MW.
- C.** This MOU is applicable to Phase I only.
- D.** Each of the Parties is a Balancing Authority (BA) and as such, operate its respective Balancing Authority Area (BAA).
- E.** PacifiCorp has requested and SRP has agreed that Cove Fort Phase will be located in the SRP BAA (see Exhibit 1).
- F.** The Parties wish to establish between their respective BAAs a common metered tie point to provide shared, or common, meter data. Cove Fort, within SRP’s BAA will transmit its energy output to interconnection facilities in the PacifiCorp BAA (See Exhibit 1). From such interconnection facilities, other arrangements

will be made for further transmission service, including ultimately into the SRP BA.

- G.** The common metered tie point will facilitate the sharing of data for the Parties' respective uses in Balancing Authority activities and obligations.

NOW THEREFORE, in consideration of the mutual covenants set forth herein, THE PARTIES AGREE as follows:

- 1. Terms** – Capitalized terms can be found in the NERC Glossary of Terms located on the NERC website.

2. Description of Cove Fort Interconnection

- a. The Cove Fort generation facility, owned by Enel, is connected to an appurtenant electrical facility, the 12.47kV/138kV Sulpherdale Substation, which is also owned by Enel. Sulpherdale is in the SRP BAA. A 1700 foot 138kV transmission line, owned and operated by PacifiCorp, transmits Cove Fort generation to the 138 kV Tushar Substation (“Tushar”)(see Exhibit 2 – One Line Diagram). The common metered tie point is located at Tushar. Tushar is part of PacifiCorp’s transmission system, is located in PacifiCorp’s BAA, and houses the meters and remote terminal units (“RTUs”) associated with the common metered tie point. Data from Cove Fort will be transferred to Sulpherdale and then to the Tushar RTUs.

3. Metering and RTUs

- a. PacifiCorp will design, procure, install, own and maintain two revenue quality meters within Tushar. One meter will be designated a primary meter and the second meter will be used as a backup meter. The primary meter will be used as the common meter for the common metered tie point between PacifiCorp’s BAA and SRP’s BAA.
- b. PacifiCorp will procure, install and maintain the Tushar primary and backup RTUs.
- c. See Exhibit 3 for a Communications Diagram.

4. Communication Paths and Data Access

- a. Each Party bears responsibility for establishing its own communication paths to access the Tushar RTUs and transfer such data into each Party's Energy Management System ("EMS").
- b. PacifiCorp Communication Path(s): PacifiCorp will provide a channel from the Tushar RTU to PacifiCorp's equipment at Arizona Public Service's (APS) Four Corners substation. SRP will be responsible to bring a communications channel from the Four Corners substation to the SRP control center.
- c. SRP Communication Paths: SRP requires two communication paths. SRP will establish one communication path to/from the Tushar RTU and SRP's EMS. The other communication path will be via ICCP (InterControl Center Communications Protocol) over the WON (WECC Operation Network). Data transferred via ICCP will flow from PacifiCorp's EMS to SRP's EMS. SRP needs to receive MW analog (best update frequency rate available), MWhr (pulse accumulator), and Unit On/Off line status.
- d. PacifiCorp Data Access: PacifiCorp will port to the Tushar RTU and transfer the real time data to its EMS. This data shall consist of MW analog (2 second update frequency rate), MWhr (pulse accumulator), and Unit On/Off line status.
- e. SRP Data Access: SRP will port to the Tushar RTU for access to the real time data needed for its EMS. This data shall consist of MW analog (2 second update frequency rate), MWhr (pulse accumulator), and Unit On/Off line status.
- f. Billing Data: SRP will have direct phone access to the metering located at Tushar. This connection will be separate from PacifiCorp's MV-90 data stream. Enel will supply direct access phone line to Cove Fort Admin Building. PacifiCorp will supply a channel to connect this phone line between Cove Fort Admin Building and Tushar substation to provide for the SRP meter connection. This phone line will tie into a PacifiCorp-supplied and owned multiplexing device.

5. Cost Responsibility

The following items are the sole cost obligation of PacifiCorp.

- i. Costs directly associated with the creation and maintenance of the ICCP association used to transfer data from the PacifiCorp EMS to the SRP EMS.
- ii. Maintenance of SRP's communication path from Tushar/PacifiCorp RTU to PacifiCorp's equipment at APS's Four Corners substation via PacifiCorp's Lake Mountain Communication Site.
- iii. Cost of the directly connected phone line from the metering at Tushar substation, back to the associated multiplexer at Cove Fort Admin Building. The phone line is to be procured by Enel.
- iv. Installation, maintenance and upgrades of the Tushar/PacifiCorp RTU.
- v. Maintenance of PacifiCorp's communication path from the Tushar/PacifiCorp RTU to PacifiCorp's EMS.

6. Tagging and Settlements

- a. The Parties will comply with all applicable WECC and NERC Reliability Standards, including those for Balancing Authority Interchange.
- b. SRP, as the source and sink BA and the Load Serving Entity ("LSE"), shall issue a Pseudo-Tie tag type for day-ahead energy scheduling. The Pseudo-Tie tag will be adjusted hour ahead by SRP if the day ahead energy profile deviates by more than +/- 25 MW in accordance with NERC Reliability Standards. In addition, the Pseudo-Tie tag will be adjusted by SRP after the fact to reflect the actual integrated hourly MW value.
- c. SRP shall register Cove Fort as a Source within the SRP BA in the Electric Industry Registry (webRegistry software).
- d. SRP shall establish an adjacency with PacifiCorp in the WECC Interchange Tool (WIT).
- e. The Pseudo-Tie tag shall be used for day ahead and hour ahead estimates and end-of-hour adjusted totals.
- f. Hourly settlement – As adjacent BAAs the Parties will perform routine hourly end-of-hour settlement of net interchange.

7. BAA Responsibilities and Acknowledgments

- a. SRP has the responsibility for generation planning, reporting, outage coordination and WECC outage notification.
- b. PacifiCorp will be the Planning Authority for the Cove Fort and the common metered tie- line.

8. Contingency Response

Should electronic communications fail, and SRP is no longer receiving data from both the Tushar RTU and via ICCP, PacifiCorp will provide to SRP, by telephone, the current level of Cove Fort generation as frequently as practical until the telemetry communications has been restored.

9. Effective Date and Termination

- a. This MOU is effective upon the date it is accepted by the Federal Energy Regulatory Commission.
- b. This MOU will continue until terminated by the written mutual agreement of the Parties.

10. Jury Waiver

TO THE FULLEST EXTENT PERMITTED BY LAW, EACH OF THE PARTIES HERETO WAIVES ANY RIGHT IT MAY HAVE TO A TRIAL BY JURY IN RESPECT OF LITIGATION DIRECTLY OR INDIRECTLY ARISING OUT OF, UNDER OR IN CONNECTION WITH THIS AGREEMENT. EACH PARTY FURTHER WAIVES ANY RIGHT TO CONSOLIDATE, OR TO REQUEST THE CONSOLIDATION OF, ANY ACTION IN WHICH A JURY TRIAL HAS BEEN WAIVED WITH ANY OTHER ACTION IN WHICH A JURY TRIAL CANNOT BE OR HAS NOT BEEN WAIVED.

APPROVAL

The Parties hereby approve this Agreement to become effective as of the date signed by both Parties.

**SALT RIVER PROJECT
AGRICULTURAL IMPROVEMENT
AND POWER DISTRICT**

PacifiCorp

/s/ Mark Avery
By
Manager, Trans Services
Title

23 July 2013
Date

/s/ Rick Vail
By
VP - Transmission
Title

8/6/13
Date

Exhibit 1 – Cove Fort Common Metered Tie Point

[See scanned pdf for image]

Exhibit 2 – One Line Diagram

[See scanned pdf for image]

Exhibit 3 – Communications Diagram

[See scanned pdf for image]

Memorandum of Understanding
For Operation of a Common Metered Tie Point
Between
Salt River Project Agricultural Improvement and Power District
And
PacifiCorp

This Memorandum of Understanding for Operation of a Common Metered Tie Point (“MOU”) sets forth the operational roles and responsibilities as between the Salt River Project Agricultural Improvement and Power District (“SRP”) and PacifiCorp. The MOU further specifies metering, data and communication arrangements associated with the Cove Fort generation facility, as related to the common metered tie point. SRP and PacifiCorp hereinafter may also be referred to individually as a “Party” and collectively as “Parties.”

WHEREAS:

- A. Cove Fort generating facility (“Cove Fort”) is a planned 65 MW geothermal plant located in Beaver County, Utah, owned by Enel Green Power (“Enel”) and interconnected to the PacifiCorp transmission system.
- B. Cove Fort is planned to be completed in two (2) phases, with Phase I built to generate 25 MW and Phase II planned for 40 MW.
- C. This MOU is applicable to Phase I only.
- D. Each of the Parties is a Balancing Authority (BA) and as such, operate its respective Balancing Authority Area (BAA).
- E. PacifiCorp has requested and SRP has agreed that Cove Fort Phase will be located in the SRP BAA (see Exhibit 1).
- F. The Parties wish to establish between their respective BAAs a common metered tie point to provide shared, or common, meter data. Cove Fort, within SRP’s BAA will transmit its energy output to interconnection facilities in the PacifiCorp BAA (See Exhibit 1). From such interconnection facilities, other arrangements will be made for further transmission service, including ultimately into the SRP BA.
- G. The common metered tie point will facilitate the sharing of data for the Parties’ respective uses in Balancing Authority activities and obligations.

JUL 26 2000

NOW THEREFORE, in consideration of the mutual covenants set forth herein, THE PARTIES AGREE as follows:

1. **Terms** – Capitalized terms can be found in the NERC Glossary of Terms located on the NERC website.

2. **Description of Cove Fort Interconnection**

a. The Cove Fort generation facility, owned by Enel, is connected to an appurtenant electrical facility, the 12.47kV/138kV Sulpherdale Substation, which is also owned by Enel. Sulpherdale is in the SRP BAA. A 1700 foot 138kV transmission line, owned and operated by PacifiCorp, transmits Cove Fort generation to the 138 kV Tushar Substation (“Tushar”)(see Exhibit 2 – One Line Diagram). The common metered tie point is located at Tushar. Tushar is part of PacifiCorp’s transmission system, is located in PacifiCorp’s BAA, and houses the meters and remote terminal units (“RTUs”) associated with the common metered tie point. Data from Cove Fort will be transferred to Sulpherdale and then to the Tushar RTUs.

3. **Metering and RTUs**

- a. PacifiCorp will design, procure, install, own and maintain two revenue quality meters within Tushar. One meter will be designated a primary meter and the second meter will be used as a backup meter. The primary meter will be used as the common meter for the common metered tie point between PacifiCorp’s BAA and SRP’s BAA.
- b. PacifiCorp will procure, install and maintain the Tushar primary and backup RTUs.
- c. See Exhibit 3 for a Communications Diagram.

4. **Communication Paths and Data Access**

- a. Each Party bears responsibility for establishing its own communication paths to access the Tushar RTUs and transfer such data into each Party’s Energy Management System (“EMS”).
- b. PacifiCorp Communication Path(s): PacifiCorp will provide a channel from the Tushar RTU to PacifiCorp’s equipment at Arizona Public Service’s (APS) Four Corners substation. SRP will be responsible to bring a communications channel from the Four Corners substation to the SRP control center.
- c. SRP Communication Paths: SRP requires two communication paths. SRP will establish one communication path to/from the Tushar RTU and SRP’s

JUL 26 RECD

EMS. The other communication path will be via ICCP (InterControl Center Communications Protocol) over the WON (WECC Operation Network). Data transferred via ICCP will flow from PacifiCorp's EMS to SRP's EMS. SRP needs to receive MW analog (best update frequency rate available), MWhr (pulse accumulator), and Unit On/Off line status.

- d. PacifiCorp Data Access: PacifiCorp will port to the Tushar RTU and transfer the real time data to its EMS. This data shall consist of MW analog (2 second update frequency rate), MWhr (pulse accumulator), and Unit On/Off line status.
- e. SRP Data Access: SRP will port to the Tushar RTU for access to the real time data needed for its EMS. This data shall consist of MW analog (2 second update frequency rate), MWhr (pulse accumulator), and Unit On/Off line status.
- f. Billing Data: SRP will have direct phone access to the metering located at Tushar. This connection will be separate from PacifiCorp's MV-90 data stream. Enel will supply direct access phone line to Cove Fort Admin Building. PacifiCorp will supply a channel to connect this phone line between Cove Fort Admin Building and Tushar substation to provide for the SRP meter connection. This phone line will tie into a PacifiCorp-supplied and owned multiplexing device.

5. Cost Responsibility

The following items are the sole cost obligation of PacifiCorp.

- i. Costs directly associated with the creation and maintenance of the ICCP association used to transfer data from the PacifiCorp EMS to the SRP EMS.
- ii. Maintenance of SRP's communication path from Tushar/PacifiCorp RTU to PacifiCorp's equipment at APS's Four Corners substation via PacifiCorp's Lake Mountain Communication Site.
- iii. Cost of the directly connected phone line from the metering at Tushar substation, back to the associated multiplexer at Cove Fort Admin Building. The phone line is to be procured by Enel.
- iv. Installation, maintenance and upgrades of the Tushar/PacifiCorp RTU.
- v. Maintenance of PacifiCorp's communication path from the Tushar/PacifiCorp RTU to PacifiCorp's EMS.

6. Tagging and Settlements

- a. The Parties will comply with all applicable WECC and NERC Reliability Standards, including those for Balancing Authority Interchange.
- b. SRP, as the source and sink BA and the Load Serving Entity (“LSE”), shall issue a Pseudo-Tie tag type for day-ahead energy scheduling. The Pseudo-Tie tag will be adjusted hour ahead by SRP if the day ahead energy profile deviates by more than +/- 25 MW in accordance with NERC Reliability Standards. In addition, the Pseudo-Tie tag will be adjusted by SRP after the fact to reflect the actual integrated hourly MW value.
- c. SRP shall register Cove Fort as a Source within the SRP BA in the Electric Industry Registry (webRegistry software).
- d. SRP shall establish an adjacency with PacifiCorp in the WECC Interchange Tool (WIT).
- e. The Pseudo-Tie tag shall be used for day ahead and hour ahead estimates and end-of-hour adjusted totals.
- f. Hourly settlement – As adjacent BAAs the Parties will perform routine hourly end-of-hour settlement of net interchange.

7. BAA Responsibilities and Acknowledgments

- a. SRP has the responsibility for generation planning, reporting, outage coordination and WECC outage notification.
- b. PacifiCorp will be the Planning Authority for the Cove Fort and the common metered tie- line.

8. Contingency Response

Should electronic communications fail, and SRP is no longer receiving data from both the Tushar RTU and via ICCP, PacifiCorp will provide to SRP, by telephone, the current level of Cove Fort generation as frequently as practical until the telemetry communications has been restored.

9. Effective Date and Termination

- a. This MOU is effective upon the date it is accepted by the Federal Energy Regulatory Commission.
- b. This MOU will continue until terminated by the written mutual agreement of the Parties.

10. Jury Waiver

TO THE FULLEST EXTENT PERMITTED BY LAW, EACH OF THE PARTIES HERETO WAIVES ANY RIGHT IT MAY HAVE TO A TRIAL BY JURY IN RESPECT OF LITIGATION DIRECTLY OR INDIRECTLY ARISING OUT OF, UNDER OR IN CONNECTION WITH THIS AGREEMENT. EACH PARTY FURTHER WAIVES ANY RIGHT TO CONSOLIDATE, OR TO REQUEST THE CONSOLIDATION OF, ANY ACTION IN WHICH A JURY TRIAL HAS BEEN WAIVED WITH ANY OTHER ACTION IN WHICH A JURY TRIAL CANNOT BE OR HAS NOT BEEN WAIVED.

APPROVAL

The Parties hereby approve this Agreement as of the date signed by both Parties.

**SALT RIVER PROJECT
AGRICULTURAL IMPROVEMENT
AND POWER DISTRICT**

PacifiCorp

MARKS AVERY

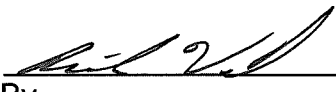
By _____
MANAGER, TRANS SERVICES
Title _____

By _____
VP-Transmission
Title _____

23 July 2013
Date _____

8/6/13
Date _____

Exhibit 1 – Cove Fort Common Metered Tie Point

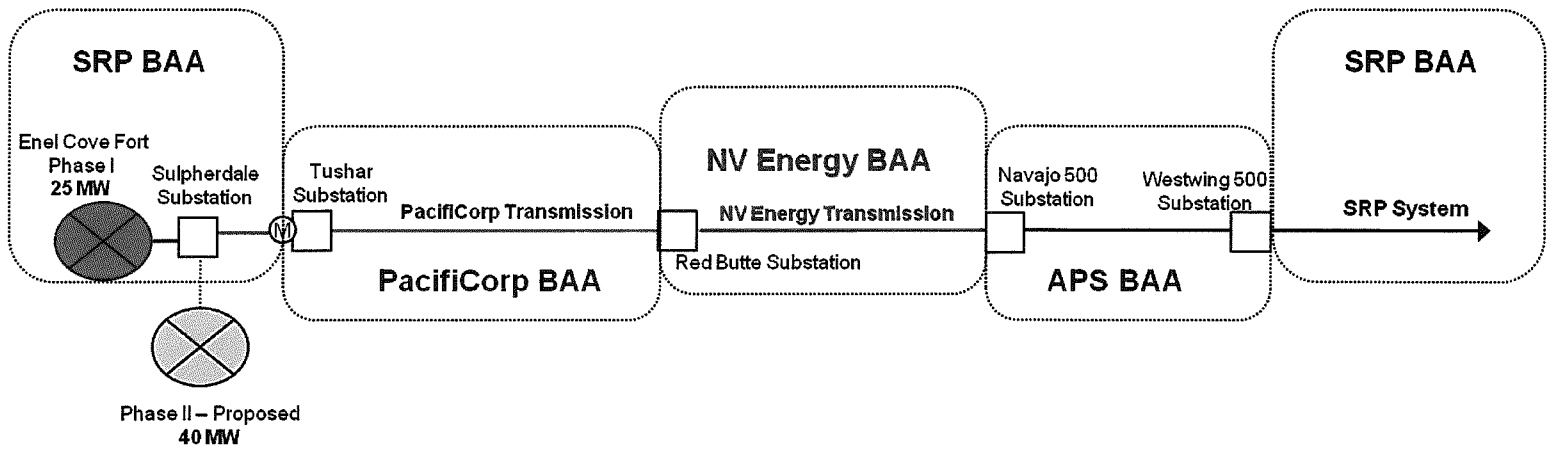

Exhibit 2 – One Line Diagram

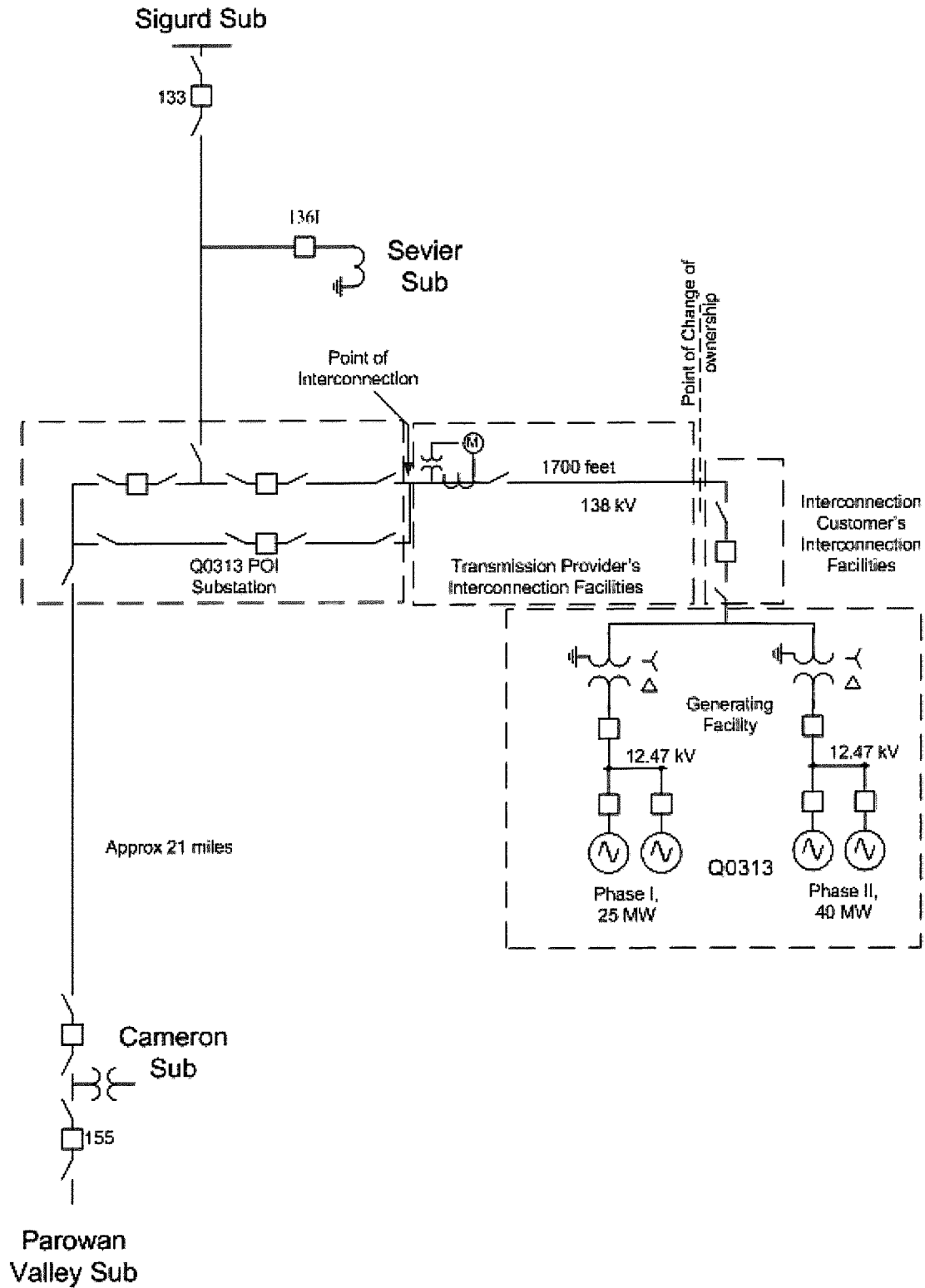
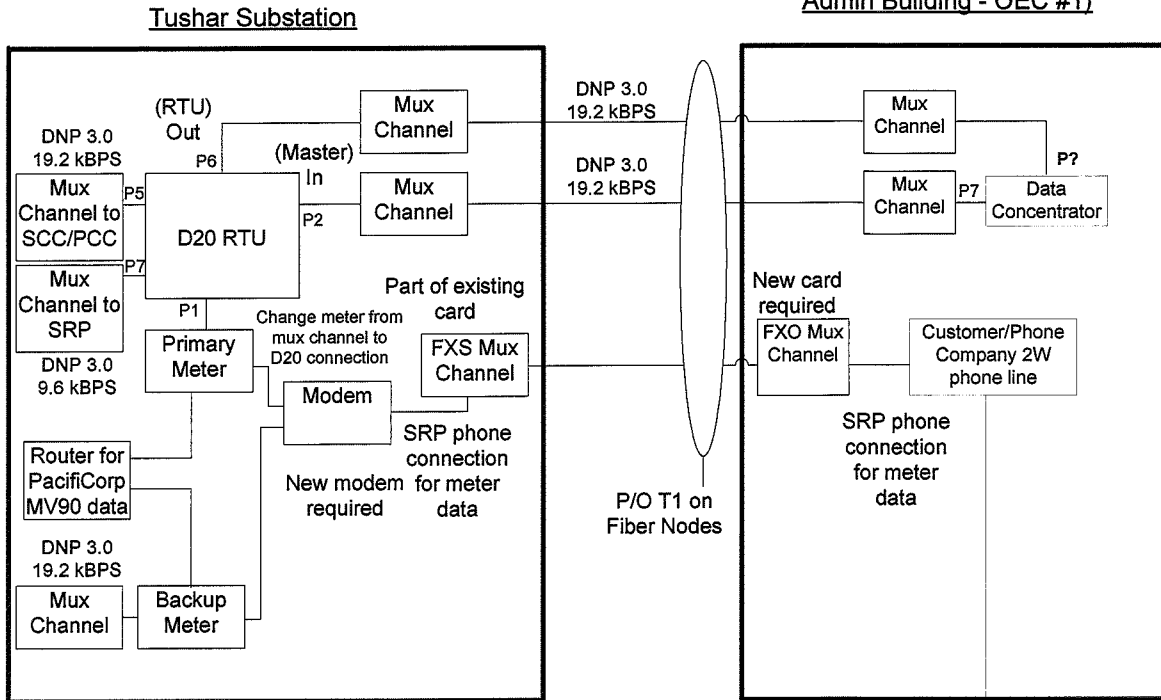

Exhibit 3 – Communications Diagram

ENEL Cove Fort – Tushar RTU/meter communications with SRP

Sulphurdale Substation (Cove Fort Admin Building - OEC #1)



- Provided by PacifiCorp
- - - Provided by Customer

Phone Company T1 line