

EU - Joint Use**Table of Contents*****Information Standards***

| <u>Standard</u> | <u>Title</u> | <u>Revision Date</u> |
|-----------------|---|----------------------|
| EU 001 | Joint Use—General Information | 10 Nov 98 |
| EU 101 | Joint Use—Pole Space Allocation | 22 Mar 07 |
| EU 211 | Joint Use—Climbing Space Through Communication Circuits | 31 May 93 |
| EU 221 | Joint Use—Clearances, Communication to Supply Circuits | 8 Nov 07 |
| EU 231 | Joint Use—Clearances, Communication Above Ground, Roadway or Water | 17 Mar 00 |
| EU 241 | Joint Use—Clearances, Communication Equipment to Risers | 17 Mar 00 |
| EU 251 | Joint Use—Clearances, Communication Equipment to Transformers | 17 Mar 00 |
| EU 261 | Joint Use—Clearances, Communication Equipment to Street Lights | 17 Mar 00 |
| EU 281 | Joint Use—Clearances, Low Voltage Service Drops | 31 May 93 |
| EU 401 | Joint Use—CATV on Poles | 22 Mar 07 |

EU

Table of Contents



Distribution Construction Standards

This page is left blank intentionally.

Joint Use—General Information

A. Scope

Joint use agreements with other utilities include standards covering the attachments involved. This section contains drawings covering joint use of poles by supply and communications circuits and equipment. These drawings conform with the applicable requirements of joint pole practices for supply and communications circuits: National Electrical Safety Code, ANSI C2–1997 (NESC); California Public Utility Commission General Order No. 95 (G.O. 95); and other state and local requirements.

B. General

The drawings in this section specify the clearances required and the typical arrangement of attachments.

Questions concerning conflicts or impaired clearances between supply circuits and communications circuits, including community antenna TV cables, which are not adequately covered by the scope or detail of this section, shall be referred to the area engineer.



These standards apply to all other utilities and other entities who own facilities which contact or are supported by equipment owned by PacifiCorp, including attachments not covered by joint use agreements.

Any trolley circuits attached to company-owned power poles will require special joint use agreements and drawings showing clearances. Trolley circuit attachments will require distribution engineering approval on a case-by-case basis.

Over-lashing of communication cables is an acceptable practice and will follow the same policy as any other attachment request. The application will be reviewed by PacifiCorp and the party being over-lashed, to determine any upgrades that may be required. The requesting party, the party that is being over-lashed, and PacifiCorp will agree to payment of the cost of any needed upgrades and the attachment fees.

The addition of the new cable will place additional loading requirements on poles and down guys and will impact the sag of the existing cable. These items will need to be reviewed to see if pole change-outs or guy replacements will be necessary.

**Distribution
Construction Standard**
© 1998 by PacifiCorp. All rights reserved.

Engineer (S. Waddoups): 
Stds Team Leader (D. Jones): 

**Joint Use
General Information**



10 Nov 98

EU 001
Page 1 of 2

EU 001

This page is left blank intentionally.



EU 001
Page 2 of 2

10 Nov 98

**Joint Use
General Information**

**Distribution
Construction Standard**

© 1998 by PacifiCorp. All rights reserved.

Engineer (S. Waddoups):

Stds Team Leader (D. Jones):

Joint Use—Pole Space Allocation

A. Scope

This standard provides information regarding the allocation of space on joint use poles for attachment of telephone, cable TV, and PacifiCorp facilities.

B. General

1. Compliance with Safety Codes and Rules

It is intended that all construction will meet or exceed the requirements of the latest edition of the National Electrical Safety Code (NESC). All work will be performed in a safe manner which complies with the rules of the NESC, the Occupational Safety and Health Administration (OSHA) and the rules of any state agencies having jurisdiction.

2. Communication Includes Telephone and Cable TV

The term “communication” is considered to include both telephone and cable TV. This is how the term is used by the NESC.

3. Available Pole Space

The setting depth of a pole in normal soil is approximately 10% of the pole length plus 2 feet. Thus a 40-foot pole will be set 6 feet into the ground with 34 feet remaining above ground; and a 45-foot pole will be set 6 1/2 feet deep with 38 1/2 feet above ground.

4. Joint Use Agreements

Some of the joint use agreements do not match all conditions set forth in the EU section of the distribution construction standards. A specific joint use agreement may spell out a different method of sharing costs of taller poles. In that case, the agreement takes precedence over this standard.

5. Bonding of Communication or Cable Equipment to Ground

When a pole ground is required by the communication utility and does not exist on the pole, the communication utility shall request the installation of a pole ground by PacifiCorp. This allows PacifiCorp to ground the neutral conductor attached to the pole. The communication company shall pay for all expenses incurred. At no time shall the communication utility personnel be in PacifiCorp’s pole space.

6. Guying and Anchoring

The communication utility shall not attach their guy wires to PacifiCorp’s anchors unless explicit written permission is given for each specific location. Anchor rod auxiliary eyes are not permitted on PacifiCorp anchors. Additionally, all guy wires installed on PacifiCorp anchors to support communication utility’s equipment or cable shall be insulated as defined by Rule 279A2a of the NESC and in accordance with PacifiCorp standard practice. This practice meets code and also prevents galvanic corrosion of anchors. The insulator shall meet NESC flashover and strength requirements. If, by written permission, PacifiCorp allows the guy wire to be bonded at the pole, an insulator is still required that meets NESC strength requirements as stated in NESC Rules 279A3 and 279A1c.



Distribution Construction Standard
 © 2007 by PacifiCorp. All rights reserved.
 Engineer (D. Asgharian): *DDA*
 Standards Manager (G. Lyons): *GL*

Joint Use Pole Space Allocation



PACIFICORP
A MIDAMERICAN ENERGY HOLDINGS COMPANY
 22 Mar 07 **EU 101**
 Page 1 of 6

EU 101

All guy wires attached to the communication utility's own anchors shall meet NESC requirements.

7. Replacing an existing pole

When PacifiCorp has need to replace an existing pole with joint use attachments and the attachment cannot immediately be transferred directly to the new pole, an alternative method of attachment may be used to reduce crew and traveling time. The following criteria must be satisfied prior to such action:

1. The pole is positioned close enough to allow attachment by this method.
2. The condition of the old pole section will maintain the integrity of the attachments.
3. No other issues are apparent that sacrifice proper clearances, safety, or working conditions.

This method of attachment should be considered temporary, and affected joint use utilities must remove their facilities within a reasonable time frame. Additionally, the last joint use utility to work on the structure must remove and dispose of the old section of the pole and DA bolts.

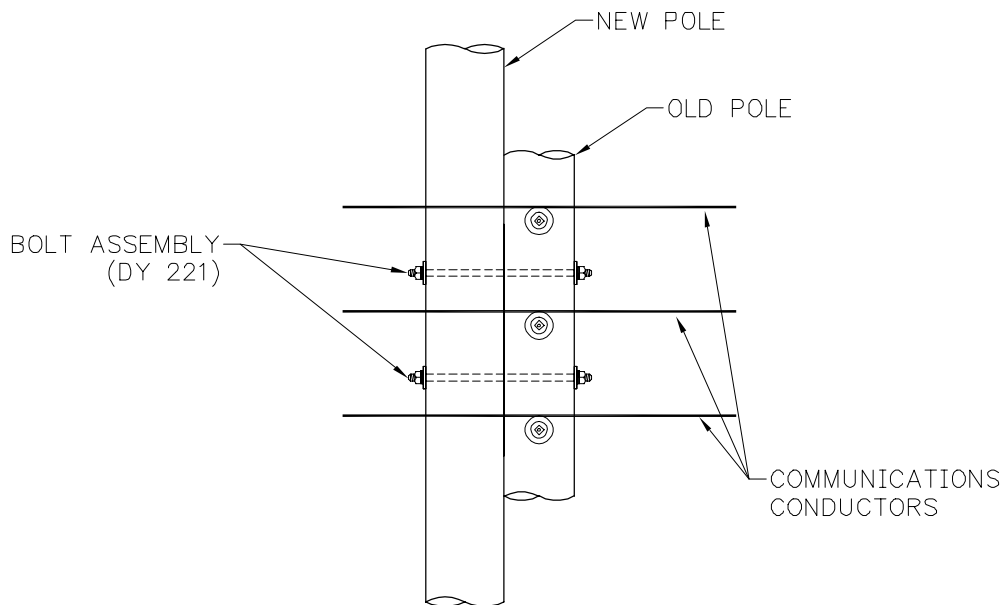

Figure 1—Pole Replacement with Existing Communications Conductors

C. Allocation of Pole Space

1. Separation Space - Permitted Uses

- a) There shall be a minimum of 40 inches of clearance between the surface (not the center) of any supply system conductors or equipment (including support hardware and washers) and any communications system conductors or equipment (including support hardware and washers).
- b) Communication equipment is not permitted to be mounted in the 40-inch separation space.

- c) Street lighting fixtures may be installed in the separation space when necessary to meet mounting height requirements provided that such installations are in accordance with the NESC and other applicable codes. For details, see EU 261. In California, see EU 271.

2. 40-Foot Basic Pole

The allocation of space and the usual points of attachments for telephone, TV cable, and electric facilities depends on the length of the "basic pole". In some areas, the basic pole is 40 feet in length (about 34 feet above ground). Figure 1 shows the space allocations and the usual points of attachment for a 40-foot joint use pole.

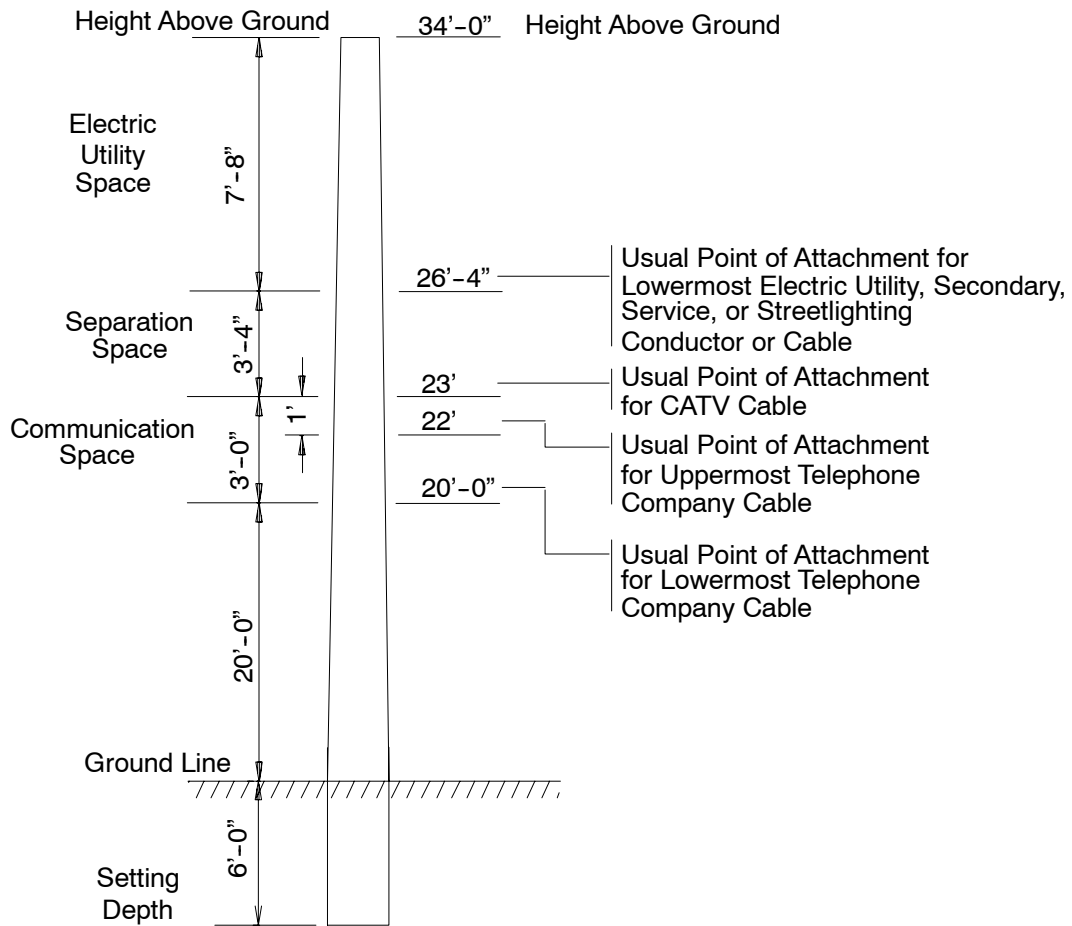

Figure 1 - Space Allocation on 40Foot Basic Joint Use Pole

EU 101

3. Poles Taller Than the 40-Foot Basic Pole

The company requiring extra pole height pays the extra cost and gets to use the extra height, less the 10% used by the deeper pole hole.

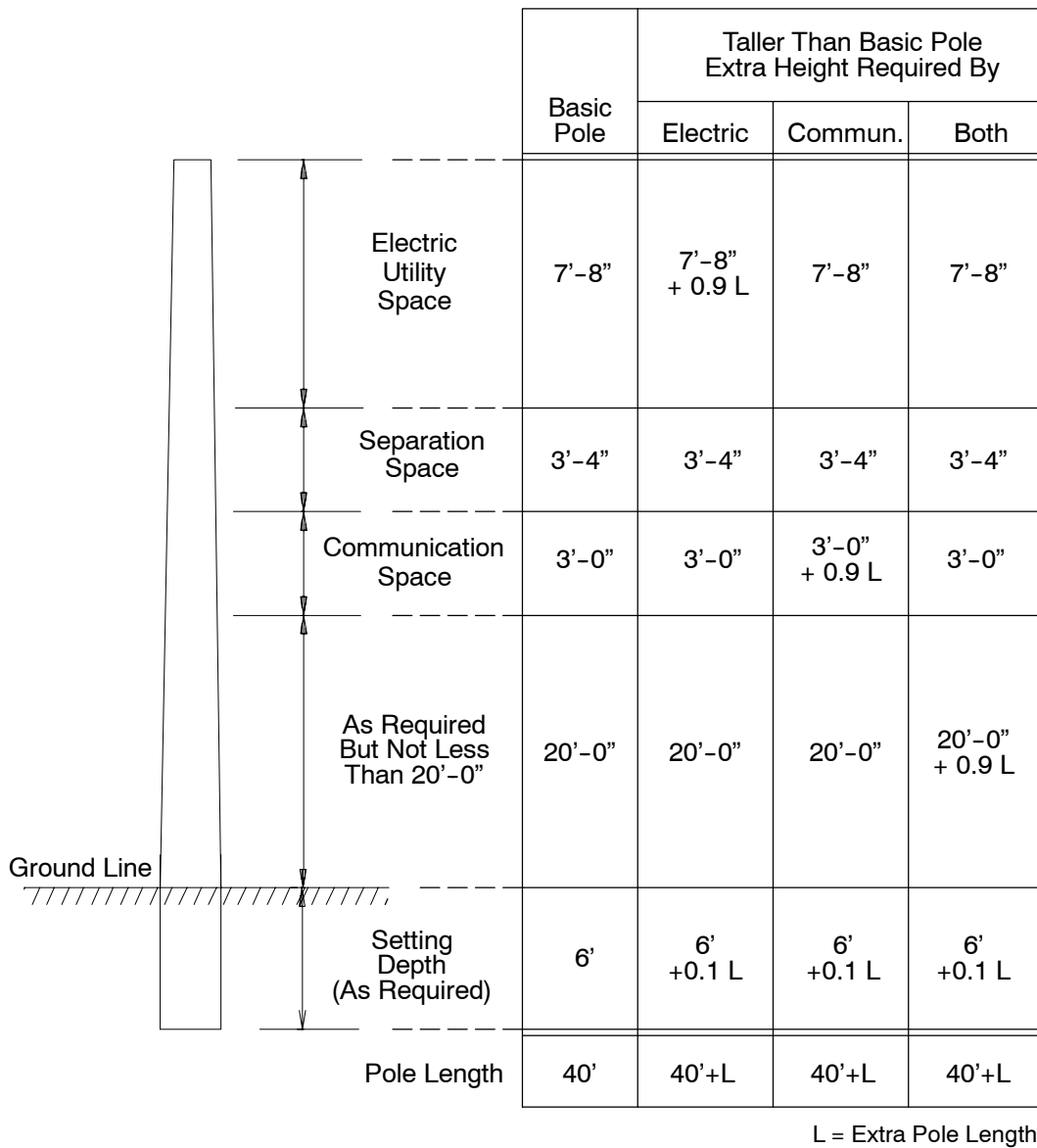

Figure 2 - Space Allocation on Poles Taller Than the 40-Foot Basic Pole



4. 45-Foot Basic Pole

The allocation of space and the usual points of attachments for telephone, TV cable, and electric facilities depends on the length of the "basic pole". In many areas, the basic pole is 45 feet in length (about 38 1/2 feet above ground). Figure 3 shows the space allocations and the usual points of attachment for a 45-foot joint use pole.

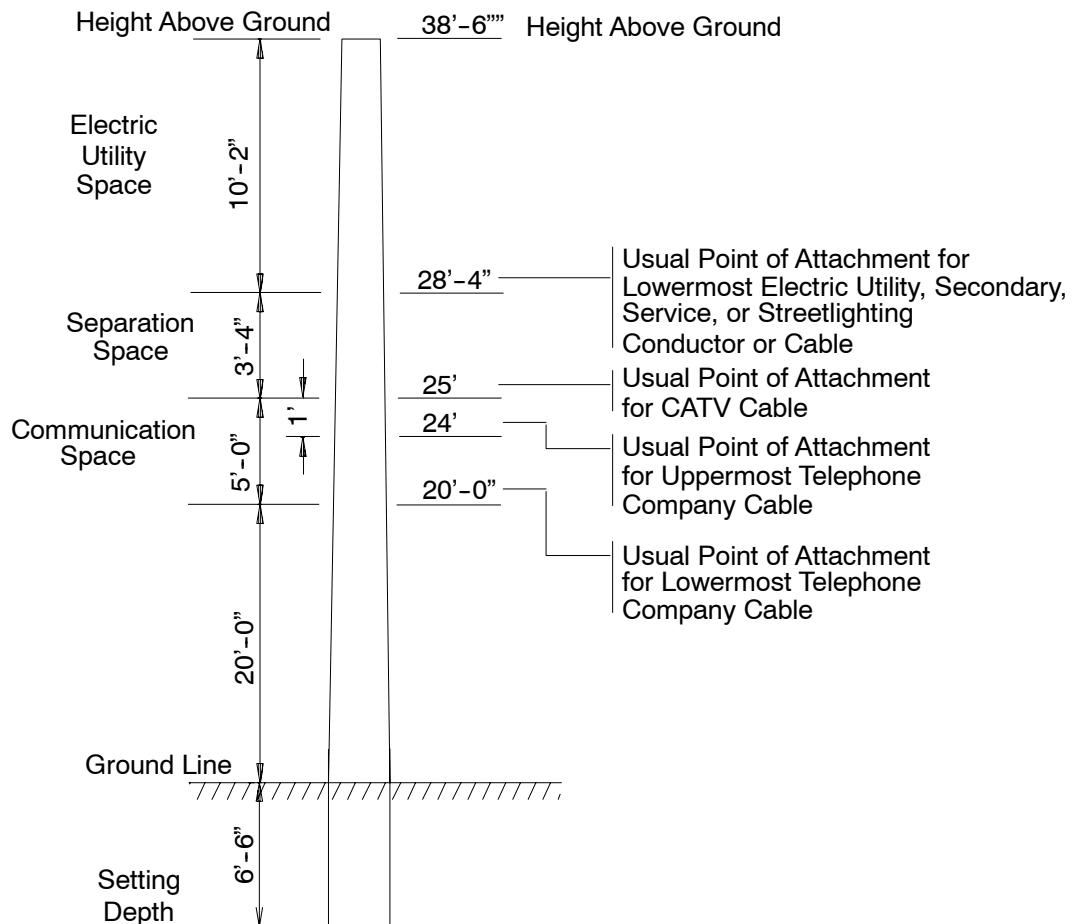

Figure 3 - Space Allocation on the 45-Foot Basic Joint Use Pole

EU 101

5. Poles Taller Than the 45-Foot basic Pole

The company requiring extra pole height pays the extra cost and gets to use the extra height, less the 10% used by the deeper pole hole.

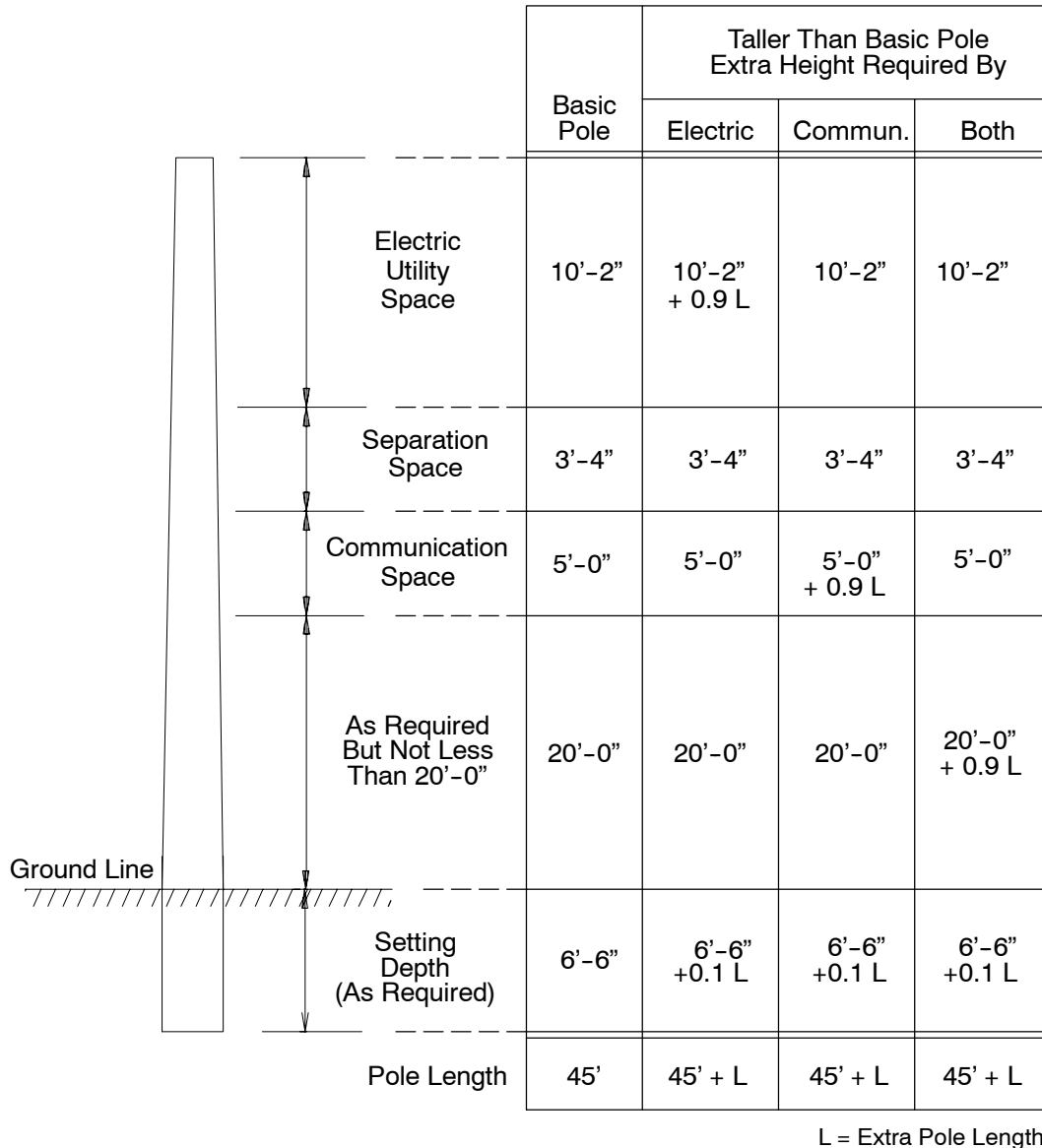

Figure 4 - Space Allocation on Poles Taller Than the 45-Foot Basic Pole



Joint Use—Climbing Space Through Communication Circuits

A. Scope

This standard provides information defining the climbing space requirements for joint use poles through the communication circuit level. Included are communication cables, service drops and vertical runs attached to the pole.

B. General

The climbing space as defined is intended to provide adequate clearances on the pole for safe ascent and descent by line personnel. The climbing space must extend 40 inches above and below the referenced communication—circuit or 48” above and below in California (see Figure 1). If the climbing space is rotated around the pole for continued climbing, the climbing spaces in different quadrants of the pole must overlap.

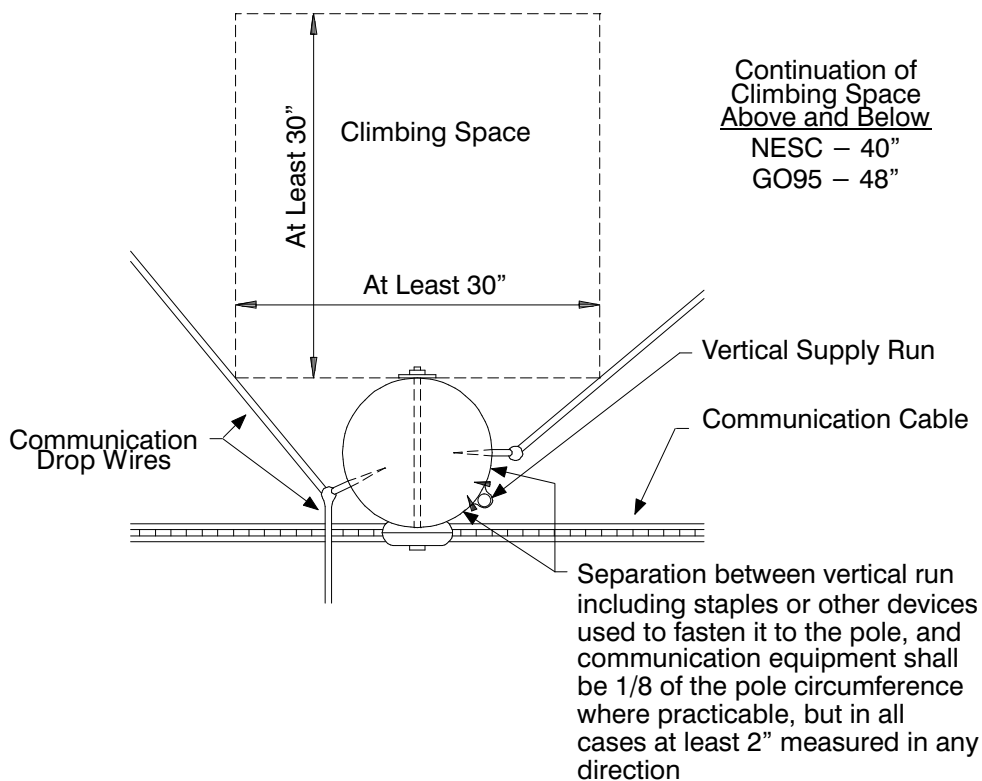

Figure 1 – Climbing Space

**Distribution
Construction Standard**

Engineer (N. J. Johnson):
Distribution Engrg. (D. Horman):
Standards Services (M. Brimhall):

**Joint Use
Climbing Space Through
Communication Circuits**

PACIFICORP
PACIFIC POWER UTAH POWER

31 May 93

EU 211
Page 1 of 1

Joint Use—Clearances, Communication to Supply Circuits

A. Scope

This standard provides information regarding vertical clearances between PacifiCorp supply circuits and joint use facilities. Included are communication circuits, neutral supports and secondary supply supports.

B. General

The vertical clearances between company supply circuits and other utility attachments are specified in this standard.

1. Vertical Spacing - Crossarms

The vertical spacing requirements between company supply circuits and communication circuits varies depending upon the voltage level and NESC and/or state (California and Washington) jurisdiction (see Figure 1 and Table 1 for clearances.).

2. Vertical Spacing - Attachments to Pole

The vertical spacing requirements between company supply circuits attached to the pole and communication circuits depends upon the supply voltage level, effectively grounded cables and NESC and/or state (California and Washington) jurisdiction (see Figure 2 and Table 2 for clearances).

3. Open Wire Communications Circuits

It is not intended that there be any new joint use poles with open wire communications circuits. Clearance to these circuits is shown because some of this type of construction still exists.

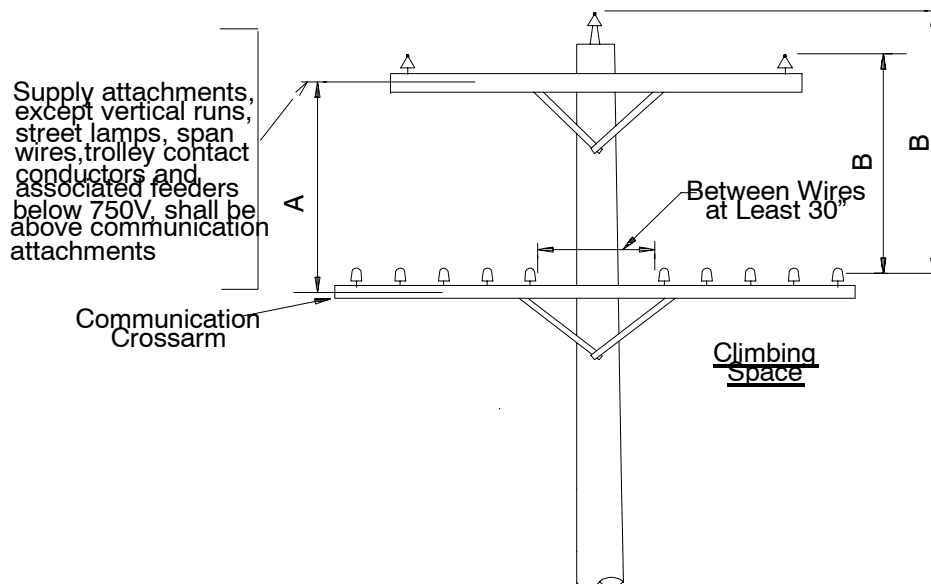

Figure 1 - Vertical Spacing of Crossarms and Circuits, Communication & Supply

EU 221

Table 1 - Vertical Clearance Between Supply and Communication Facilities

| Voltage of Supply Circuit | Min. X-arm Spacing (In.) (Dimension A) | Min. Conductor Spacing (In.) (Dimension B) |
|---------------------------|--|--|
| NESC [1] | | |
| 0-8700 | 48 | 40 |
| 8700-50000 | 72 | 60 |
| Washington [2] | | |
| 0-7500 | 48 | 40 |
| Over 7500 | 84 | 84 |
| California [2] | | |
| 0-7500 | 48 | 48 |
| 7500-75000 | 72 | 72 |

- [1] Voltage is to ground if an effectively grounded circuit, otherwise voltage is highest voltage between any two conductors.
- [2] Voltage is highest voltage between any two conductors.

California G. O. 95 exceptions, Dim. A Rule 92.1B
 0-750V supply on racks—A = 72"
 Supply cables—A = 48"

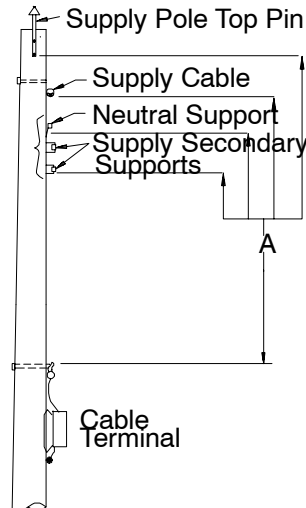

Figure 2 - Vertical Clearances Between Conductors and Noncurrent Carrying Metal Parts of Communication Equipment and Supply Circuits

Table 2 - Vertical Clearances Between Conductors and Noncurrent Carrying Metal Parts of Communication Equipment and Supply Circuits

| Dim. A | Washington | | NESC | | California | |
|--------|---|-----------------------|---|-----------------------|---|-----------------------|
| | Voltage of Supply Circuit Concerned [2] | Min. Clearance Inches | Voltage of Supply Circuit Concerned [1] | Min. Clearance Inches | Voltage of Supply Circuit Concerned [2] | Min. Clearance Inches |
| A | 0- 7500 | 40 | 0-8700 | 40 | 0-7500 | 48 |
| | Over 7500 | 84 | Over 8700 | 60 | 7500-75000 | 72 |



- ① Voltage is to ground if an effectively grounded circuit, otherwise same as ②.
- ② Voltage is highest voltage between any two conductors.

4. Horizontal Spacing

The preferred method of attaching communications cables to poles is to utilize one side of the pole with 12" minimum vertical separation between cables. This allows climbing on the other side of the pole. However, in certain circumstances, PacifiCorp will allow installation of communications cables on both sides of a pole, as long as there is a minimum of 30" horizontal separation between wires for climbing. This separation can be obtained by using fiberglass arms, strong enough to handle physical loads upon them and long enough to provide the needed 30" separation at the point of attachment to the pole (see Figure 1 and Figure 3).

(If Figure 1 is the attachment method being used, 30" horizontal measurements are required between cables. This measurement applies to any cables attached to the crossarm, but must also take into consideration any cable attached directly to the pole.)

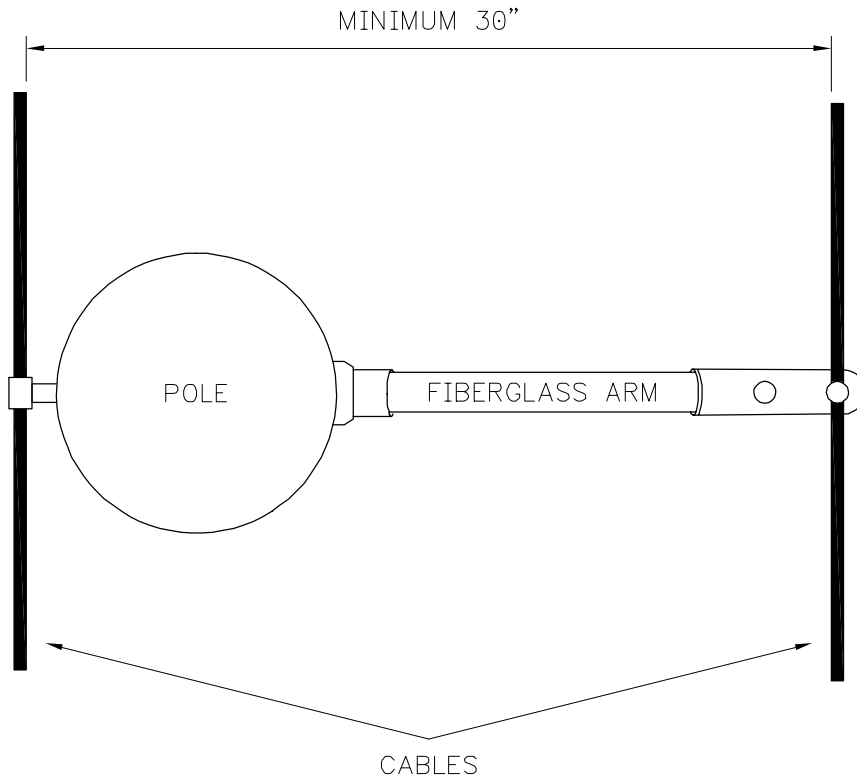

Figure 3 - Horizontal Spacing Using Fiberglass Arm

This page is left blank intentionally.



**Joint Use—Clearances,
Communication to
Supply Circuits**

**Distribution
Construction Standard**

© 2007 by PacifiCorp. All rights reserved.

Engineer (D. Asgharian): *DDA*
Standards Manager (G. Lyons): *GL*

Joint Use—Clearances, Communication Above Ground, Roadway or Water

A. Scope

This standard provides information regarding the minimum clearance required between joint use facilities attached to PacifiCorp structures and ground, roadways, and waterways.

B. General

The vertical clearances of all facilities attached to PacifiCorp structures must meet or exceed the minimum requirements of the National Electrical Safety Code (ANSI C2, current edition), and any applicable state or local codes and the requirements of the PacifiCorp construction standards. These requirements shall apply to communication circuits, fiber optic lines, cable television circuits, messenger wires, guy wires and any other foreign owned facilities attached to PacifiCorp equipment.

In the event that the owner of a foreign facility is not a public utility company, then the attached facility must also comply with the provisions of the National Electrical Code (NFPA 70).

C. Application

1. Clearances shall be maintained at maximum loading conditions as defined by NESC rule 232.
2. PacifiCorp clearance requirements are found in section DC of the Distribution Construction Standards. PacifiCorp ground clearance requirements are found in section DC 111.
3. In the event of conflicting requirements, the requirement which provides more clearance shall apply.

D. Special Requirements by State

1. Utah

For state and federal highways, the following requirements are to be followed:

- a) At intersections, minimum clearances are the applicable NESC clearance plus 13 feet.
- b) At other points adjacent to or crossing a state highway, minimum clearances are NESC clearances plus 8 feet.
- c) Crossing any public roadway, the minimum ground clearance is 18 feet.

2. Washington

Along or crossing a state or federal highway, 24 feet of ground clearance is required.

This page is left blank intentionally.

Joint Use—Clearances, Communication Equipment to Risers

A. Scope

This standard provides information regarding the location of risers and vertical runs on joint use poles. Included are company owned supply risers, communication risers and ground conductors.

B. General

Risers and vertical runs on joint use poles shall be located on poles so as to minimize congestion, provide adequate climbing space and meet clearance requirements. Whenever practicable, risers and vertical runs shall be located on the 'away from'-traffic side of the pole. If supply and communication risers are required on the same pole, they should be installed in the same quadrant away from the climbing space. For typical arrangement of joint risers, see Figure 1. For preferred arrangements of risers and vertical runs on joint poles, see Figure 2. Supply cable risers shall be installed in approved protective conduit (see standard GC 051). Supply cable carried vertically through communication attachments and supply circuits shall be attached to the pole so as to meet or exceed minimum NESC clearance requirements in all areas (see Figure 3).



EU 241

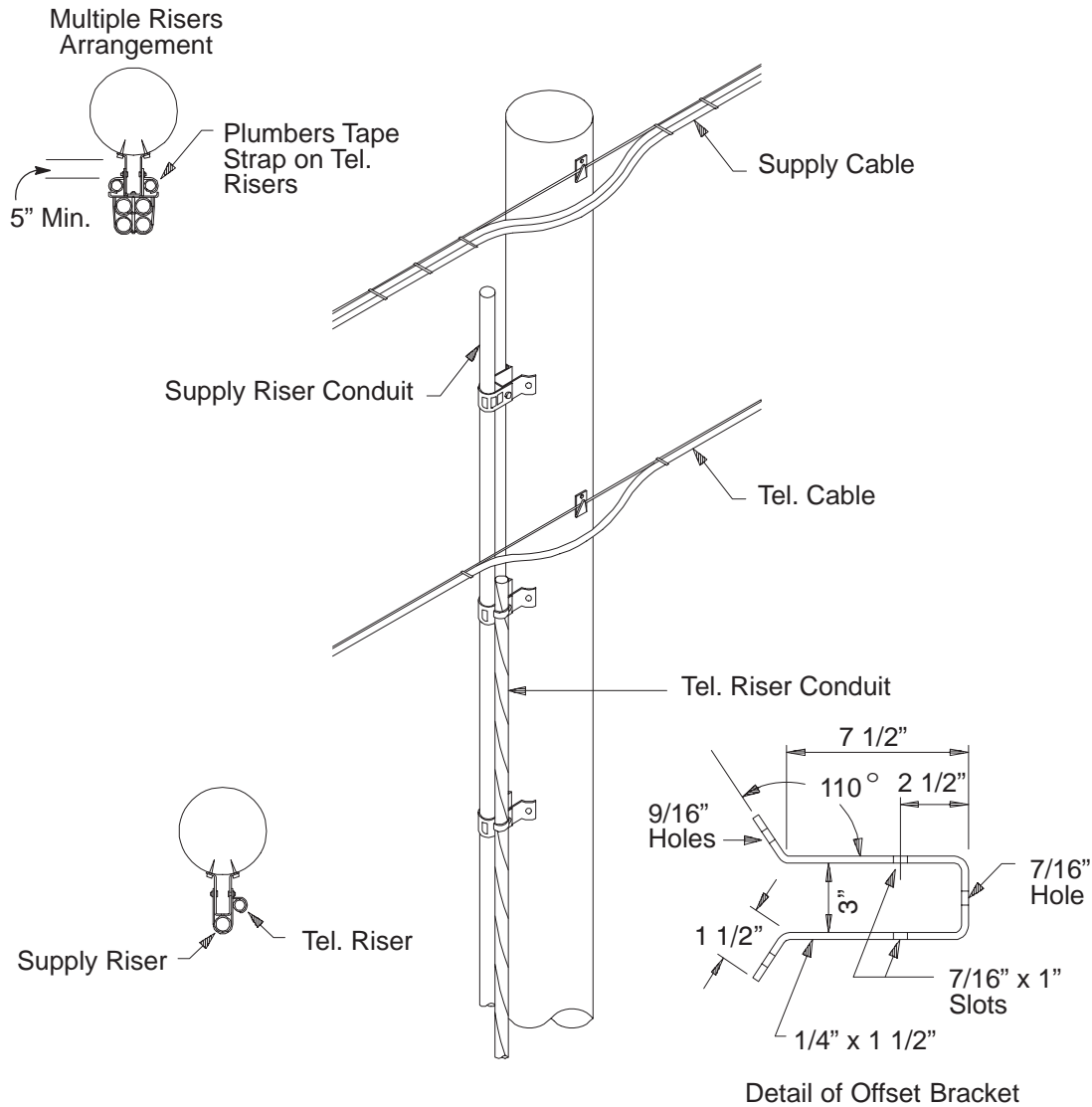

Figure 1 – Typical Arrangement of Supply and Communications Risers

NOTES:

1. Arrangement for joint use of offset bracket for support of one supply riser and one communications riser. The actual offset bracket may be another approved style. Two or more supply riser conduits will always be on offset brackets, in which case the communications riser or risers shall also be on the brackets.
2. All supply riser conduits shall be supported by offset brackets. Multiple risers, supply or communication or both shall be combined on a riser offset bracket. If a supply riser is installed on an offset bracket, the communication riser shall also be on the offset bracket.
3. Spacing between brackets shall not exceed 10 feet and provide as much clearance as possible between pole and conduit surfaces but not less than 5 inches.

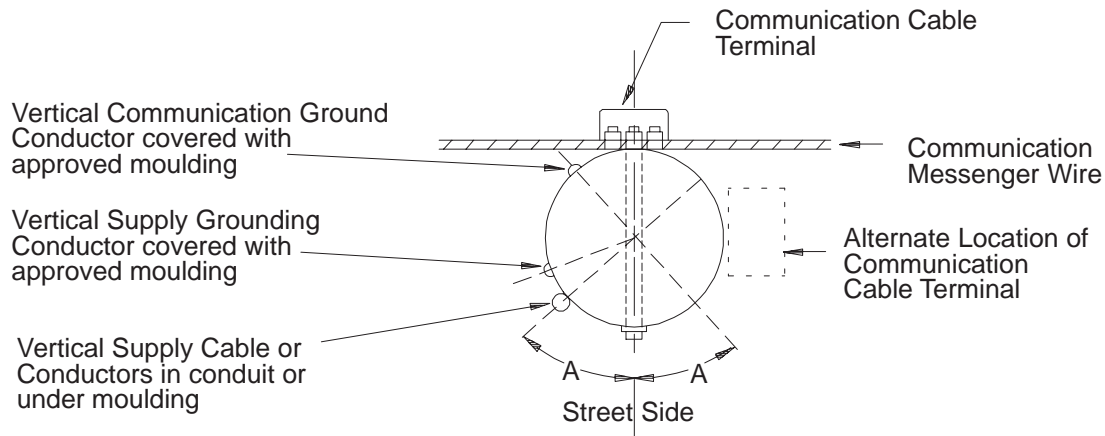

Figure 2 – Preferred Locations for Risers, etc. on Joint Use Poles

NOTES:

1. Whenever practicable, angle A should be approximately 45 degrees. The risers and vertical runs shall be located on the low side of raked and other non-vertical poles.
2. All supply riser conduits shall be supported by offset brackets. Multiple risers, supply or communication or both shall be combined on a riser offset bracket. If a supply riser is installed on an offset bracket, the communication riser shall also be on the offset bracket.
3. Spacing between brackets shall not exceed 10 feet and provide as much clearance as possible between pole and conduit surfaces but not less than 5 inches.
4. The clearance between supply hardware and communications hardware shall be as much as practicable but in no case less than 2 inches in any direction, except if all the following applies:
 - a) The systems and applicable codes involved would permit grounding of the hardware.
 - b) The hardware involved in the reduced clearance is effectively grounded at the location.
 - c) The hardware involved is mechanically and electrically securely bonded.

Distribution Construction Standard

© 2000 by PacifiCorp. All rights reserved.

Engineer (S. Waddoups): 

Stds Team Leader (D. Jones): 

Joint Use Clearances, Communication Equipment to Risers



17 Mar 00

EU 241
Page 3 of 4

EU 241

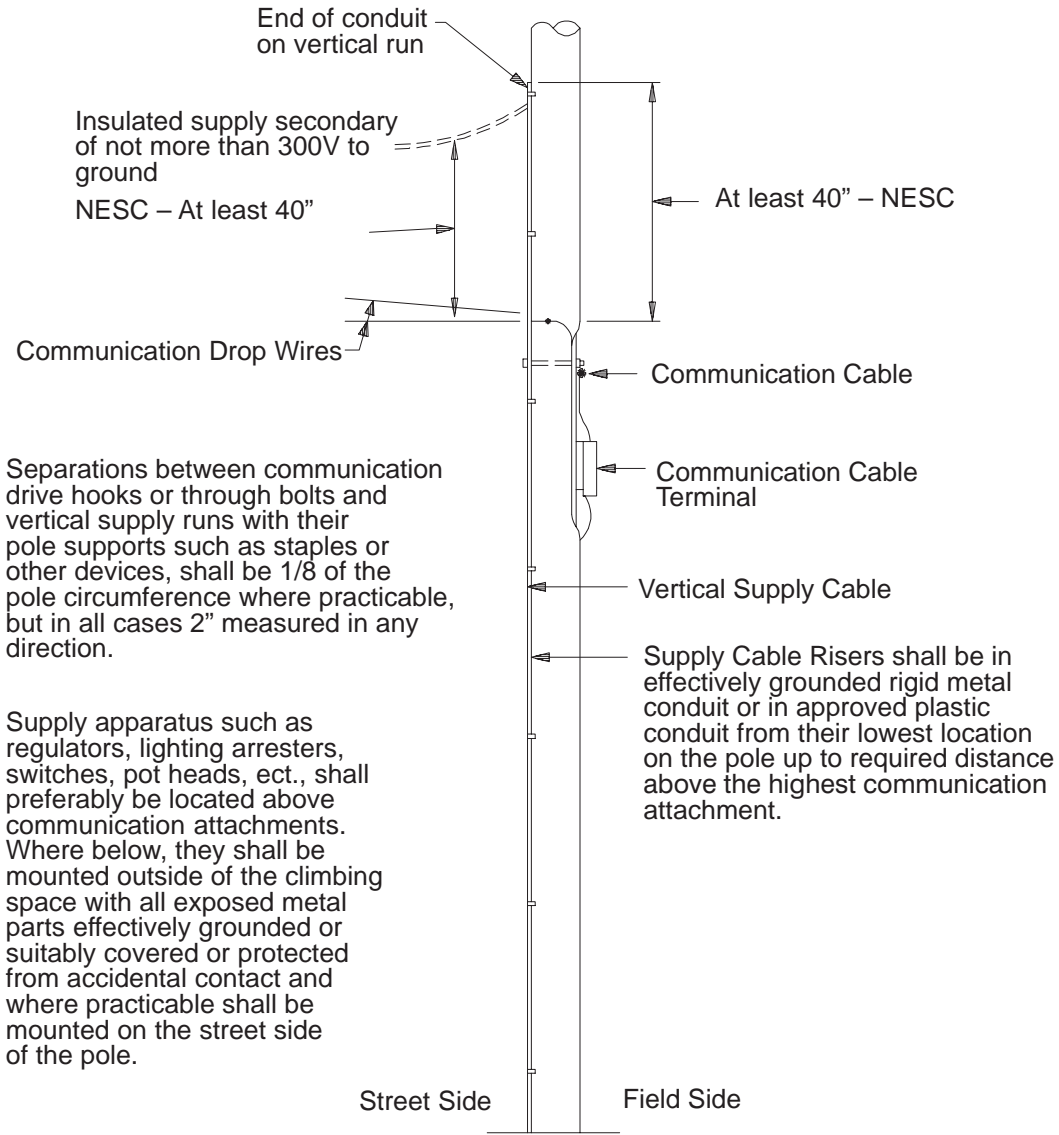

Figure 3 – Supply Riser on Joint Use Pole

Joint Use—Clearances, Communication Equipment to Transformers

A. Scope

This standard provides information regarding clearances between communication cables and supply transformers attached to joint use poles.

B. General

Clearance requirements between communication cables and supply transformers vary according to geographic location and supply system voltage. For typical joint pole arrangement with supply transformer, see Figure 1. NESC and WAC (Washington) supply transformer clearances are identical (see Table 1).

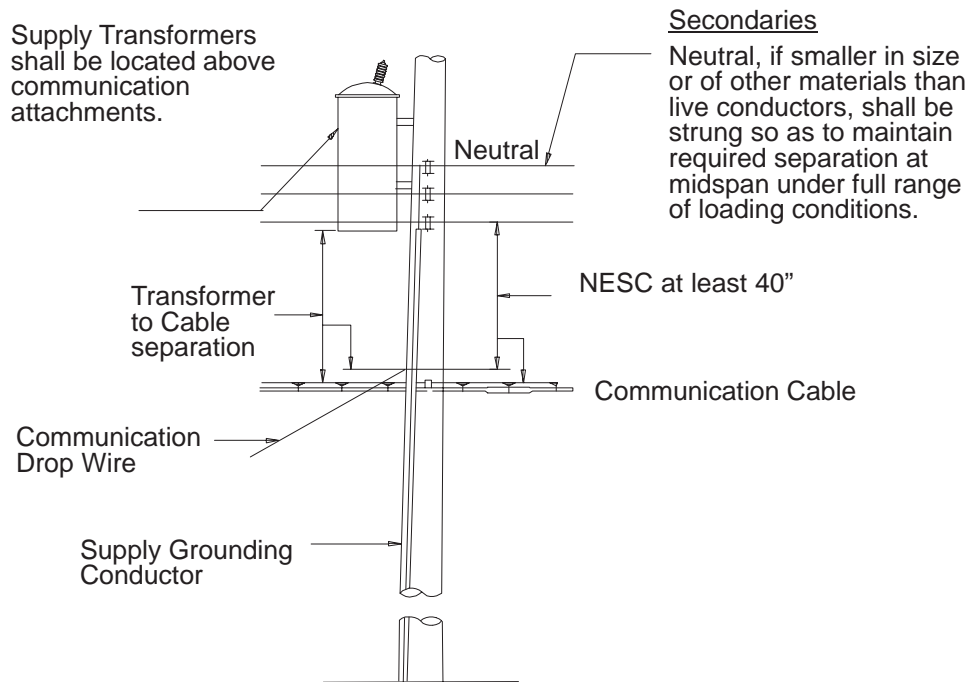

Figure 1 – Clearances Between Transformers and Communications Cables

EU 251

Table 1 – Clearance from Transformers for Communication Cables

| Transformer Primary Voltage | Minimum Clearance In Inches |
|-----------------------------|-----------------------------|
| NESC & Washington | |
| 0–8700 | 40 ¹ |
| 8700–50000 | 60 ¹ |

NOTES:

- ¹ If transformer cases are effectively grounded, these clearances may be reduced to 30 inches.
- ² With guard arm above communication cable, may be reduced to not less than 48 inches.

Joint Use—Clearances, Communication Equipment to Street Lights

A. Scope

This standard provides information regarding vertical clearances between street lights and joint use facilities. Included are clearances from communication circuits and cable T.V. to street lights and street lighting supply drip loops.

B. General

The vertical clearances between street lights, street lighting service drip loops, and communication facility attachments are specified in this standard.

1. Vertical Clearance—Communication Cable

The vertical clearances required between street lighting equipment and communication cables attached to the pole are defined on pages 2 and 4 of this standard. Street lighting may be installed above or below the communication level, provided that required clearances shown on pages 2 through 5 are met.

2. Vertical Clearance—Open Wire Telephone on Crossarm

The vertical and horizontal clearances required between street lighting equipment and open wire communication circuits on wood crossarm are defined on pages 3 and 5 of this standard. Street lighting may be installed above or below open wire communication circuits provided that required clearances shown on pages 2 through 5 are met.

Applicable in All States

**Distribution
Construction Standard**

© 2000 by PacifiCorp. All rights reserved.

Engineer (S. Waddoups): 

Stds Team Leader (D. Jones): 

**Joint Use
Clearances,
Communication
Equipment to Street Lights**



17 Mar 00

EU 261
Page 1 of 6

EU 261

ALL STATES EXCEPT CALIFORNIA

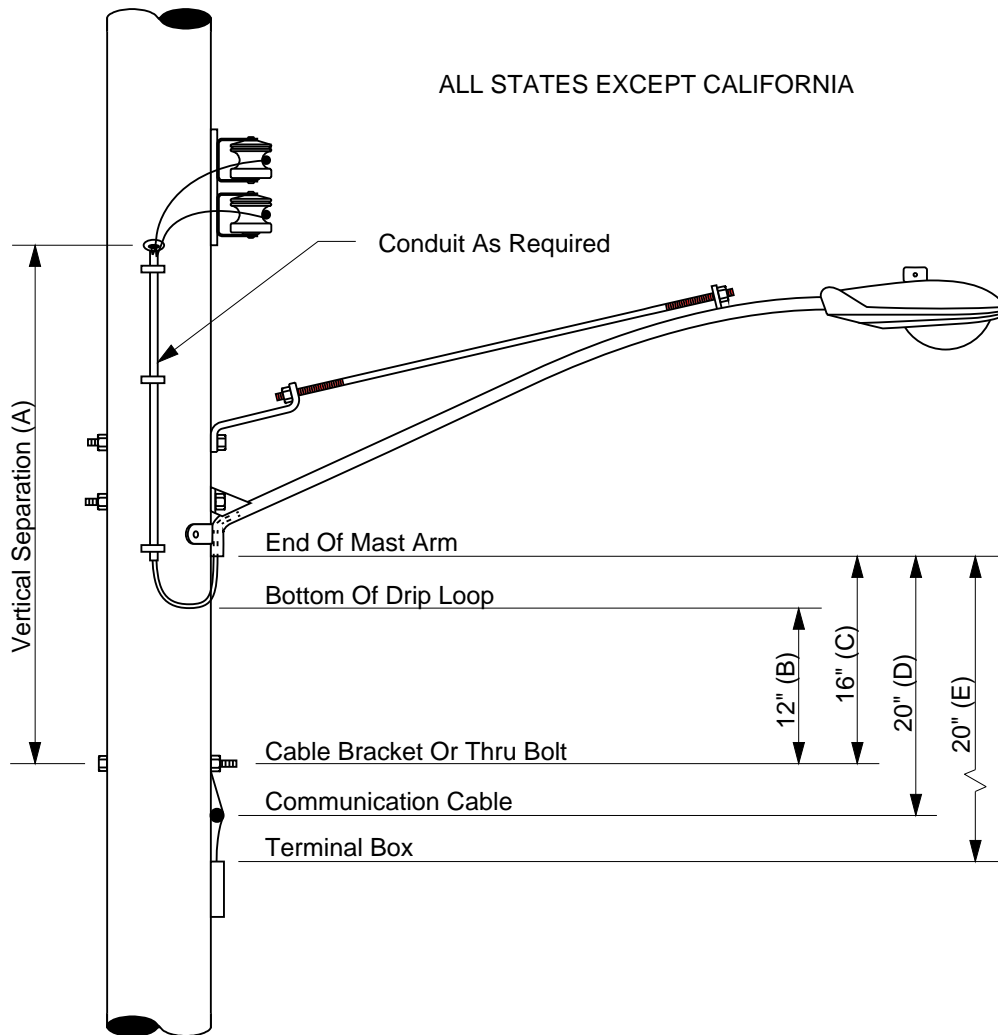

NOTE:

- A. Vertical Separation (NESC SEC. 23, #238-1)**
 40" If supply voltage is 0 – 8700 V
 60" If supply voltage is over 8700 V
- B. Separation from Drip Loops of Street Light Brackets (NESC SEC. 23, #238.D)**
- C. Separation from Communication Brackets (NESC SEC. 23, #238.2)**
- D. Separation from Messengers Carrying Communication Cables (NESC SEC. 23, #238.2)**
- E. Separation from Terminal Box of Communication Cable (NESC SEC. 23, #238.2)**

EXCEPTIONS TO CLEARANCE REQUIREMENTS
 AND ADDITIONAL NOTES, SEE PAGE 6

Figure 1 – Street Lighting Facilities Above Communication

ALL STATES EXCEPT CALIFORNIA

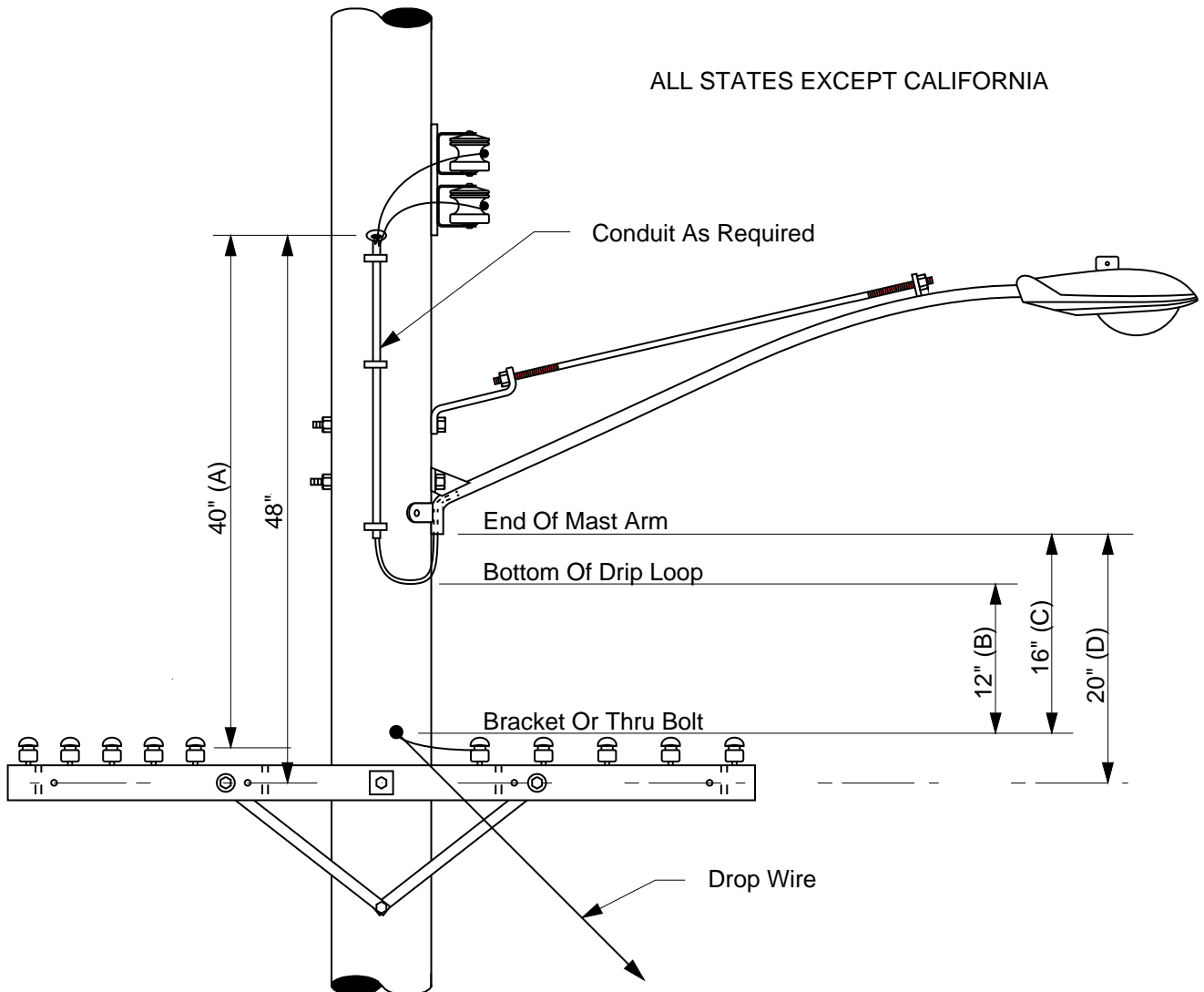

NOTE:

- A. Vertical Separation (NESC SEC. 23, #238-1)**
 40" If supply voltage is 0 – 8700 V
 60" If supply voltage is over 8700 V
- B. Separation from Drip Loops of Street Light Brackets (NESC SEC. 23, #238.D)**
- C. Separation From Communication Brackets (NESC SEC. 23, #238.2)**
- D. Separation above Communication Crossarms (NESC SEC. 23, #238.2)**

EXCEPTIONS TO CLEARANCE REQUIREMENTS
 AND ADDITIONAL NOTES, SEE PAGE 6

Figure 2 – Street Lighting Above Communication Open Wire Crossarm

Distribution Construction Standard
 © 2000 by PacifiCorp. All rights reserved.
 Engineer (S. Waddoups):
 Stds Team Leader (D. Jones):

Joint Use Clearances, Communication Equipment to Street Lights

PACIFICORP
 PACIFIC POWER UTAH POWER
 17 Mar 00
EU 261
 Page 3 of 6

EU 261

ALL STATES EXCEPT CALIFORNIA

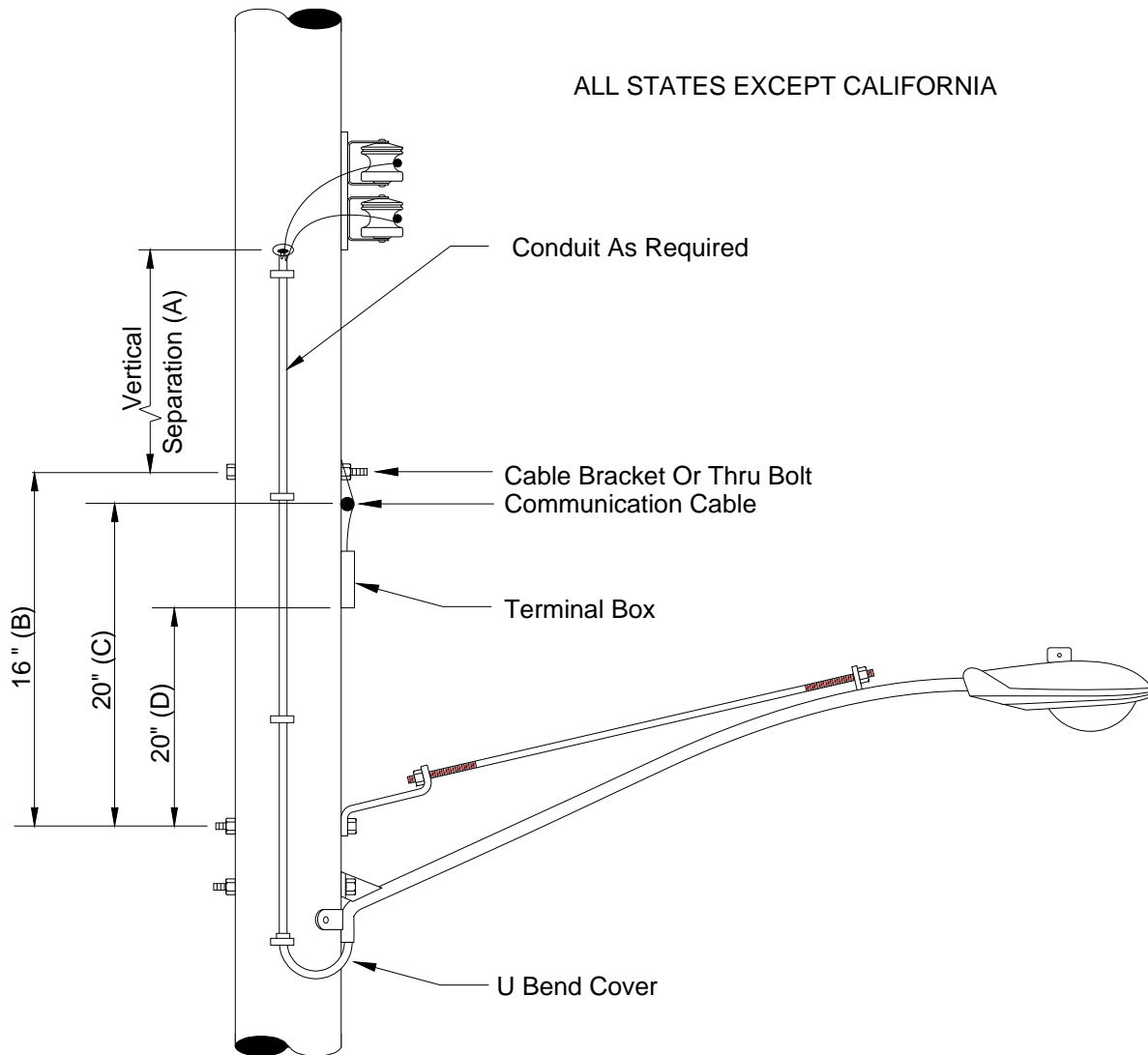

NOTE:

- A. Vertical Separation** (NESC SEC. 23, #238-1)
 40" If supply voltage is 0 – 8700 V
 60" If supply voltage is over 8700 V
- B. Separation from Communication Brackets** (NESC SEC. 23, #238.2)
- C. Separation From Messengers Carrying Communication Cables**
 (NESC SEC. 23, #238.2)
- D. Separation From Terminal Box of Communication Cable** (NESC SEC. 23, #238.2)

EXCEPTIONS TO CLEARANCE REQUIREMENTS
 AND ADDITIONAL NOTES, SEE PAGE 6

Figure 3 – Street Lighting Facilities Below Communication

ALL STATES EXCEPT CALIFORNIA

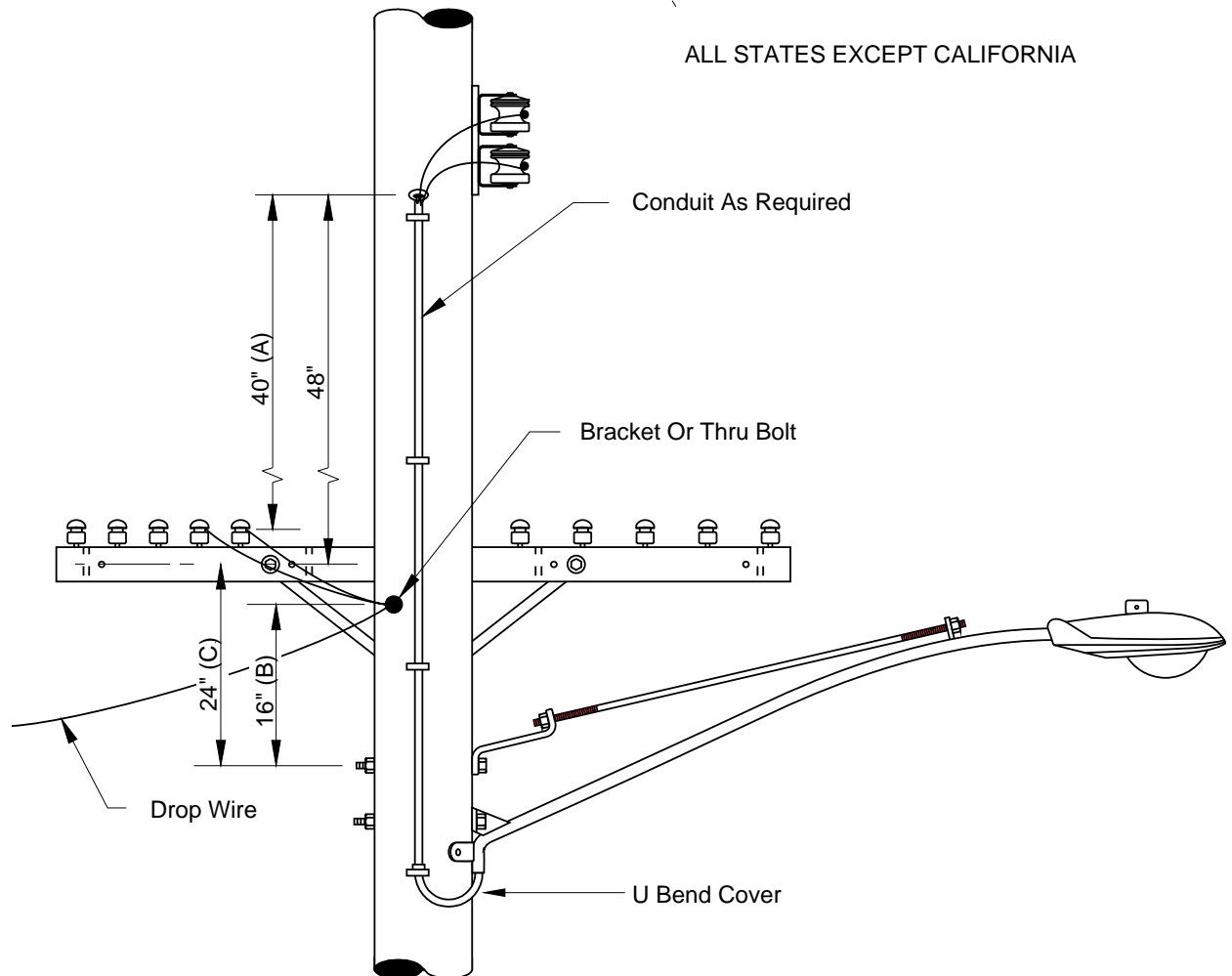



NOTE:

- A. Vertical Separation (NESC SEC. 23, #238-1)**
 40" If supply voltage is 0 – 8700 V
 60" If supply voltage is over 8700 V
- B. Separation from Communication Brackets (NESC SEC. 23, #238.2)**
- C. Separation Below Communication crossarms (NESC SEC. 23, #238.2)**

EXCEPTIONS TO CLEARANCE REQUIREMENTS
 AND ADDITIONAL NOTES, SEE PAGE 6

Figure 4 – Street Lighting Below Communication Open Wire Crossarm

Distribution Construction Standard
 © 2000 by PacifiCorp. All rights reserved.

Engineer (S. Waddoups): 
 Stds Team Leader (D. Jones): 

**Joint Use Clearances,
 Communication Equipment to Street Lights**

 **PACIFICORP**
 PACIFIC POWER UTAH POWER

17 Mar 00

EU 261
 Page 5 of 6

EU 261

C. Exceptions to Clearance Requirements Shown

1. Vertical Separation A as Illustrated on Sheets 2, 3, 4, and 5

Where noncurrent carrying parts of equipment and supply cables are effectively grounded consistently throughout well-defined areas, and where communication is at lower levels, separations may be reduced to 30 inches.

2. Conditions for a Reduction in Required Separation

The following dimensions may be reduced in special cases:

- d) C, D, and E as illustrated on sheet 2
- e) C, and D as illustrated on sheet 3
- f) B, C, and D as illustrated on sheet 4
- g) B, and C as illustrated on sheet 5

These special cases are as follows:

- a) The separation may be reduced to 12 inches for either span wires or metal parts of brackets at points 40 inches or more from the pole surface.
- b) The separation may be reduced to 4 inches if the noncurrent carrying metal parts of the street light assembly are effectively grounded.

3. Other Exceptions

For dimension B of sheets 2 and 3, the distance of 12 inches may be reduced to 3 inches if the loop is covered by a suitable nonmetallic covering which extends at least 2 inches beyond the loop.

Drip loop requirements do not have to be followed if the supply run is in continuous conduit or covered by a U bend.

Applicable in All States





EU 261
Page 6 of 6

17 Mar 00

**Joint Use
Clearances,
Communication
Equipment to Street Lights**

**Distribution
Construction Standard**
© 2000 by PacifiCorp. All rights reserved.

Engineer (S. Waddoups): 
Stds Team Leader (D. Jones): 

Joint Use—Clearances, Communication Equipment to Street Lights—California

A. Scope

This standard provides information regarding clearances between streetlights and communication attachments on joint use poles in the State of California. Included are open wire communication circuits on crossarms, cable attached directly to the pole and secondary supply circuits.

B. General

Joint use clearances for streetlights installed in California are under the jurisdiction of GO 95 which equals or exceeds NESC requirements. Streetlights may be installed above or below communication circuits provided that required clearances are met (see Figure 1 below for clearances).

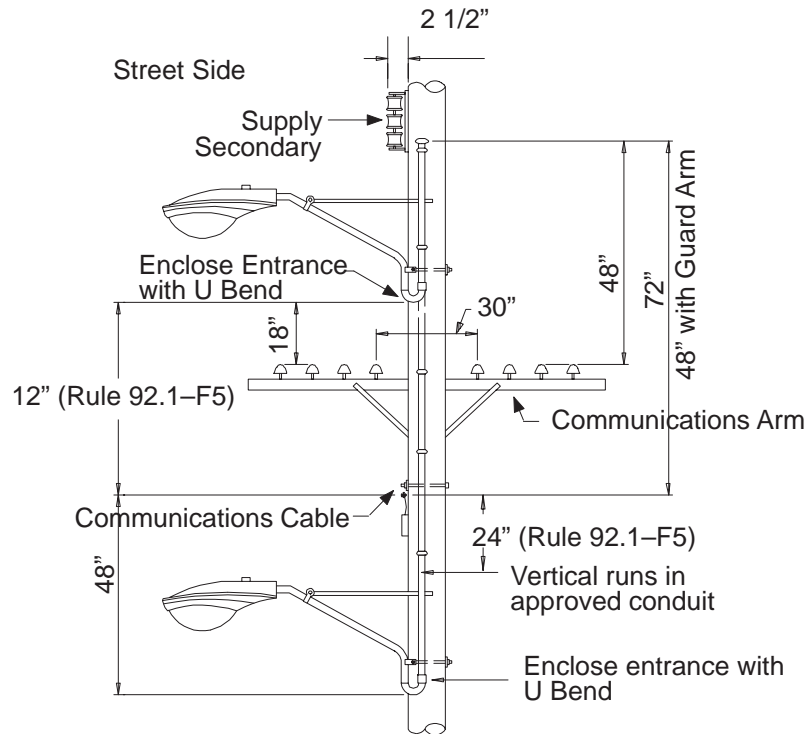

Figure 1 – Clearances Between Street Lights and Communication Attachments

NOTE:

1. Hardware Clearances 2 Inches

**Distribution
Construction Standard**

Engineer (K. M. Shortt): *KS*
 Stds Team Leader (D. Jones): *DJ*
 Standards Services (M. Brimhall): *MB*

**Joint Use
Clearances, Communication
Equipment to Street Lights
California**

PACIFICORP
 PACIFIC POWER UTAH POWER

2 Sep 97

EU 271
 Page 1 of 2

This page is left blank intentionally.



**Joint Use
Clearances, Communication
Equipment to Street Lights
California**

**Distribution
Construction Standard**

Engineer (K. M. Shortt): *KS*
Stds Team Leader (D. Jones): *RDJ*
Standards Services (M. Brimhall): *MB*

Joint Use—Clearances, Low Voltage Service Drops

A. Scope

This standard provides information regarding clearances between company owned supply service drops and communication attachments on joint use poles in California, Washington, and all other service areas.

B. General

This standard includes clearances between supply service drops from 0–750V and open wire communication circuits on crossarms (see Figure 1 below for clearances).

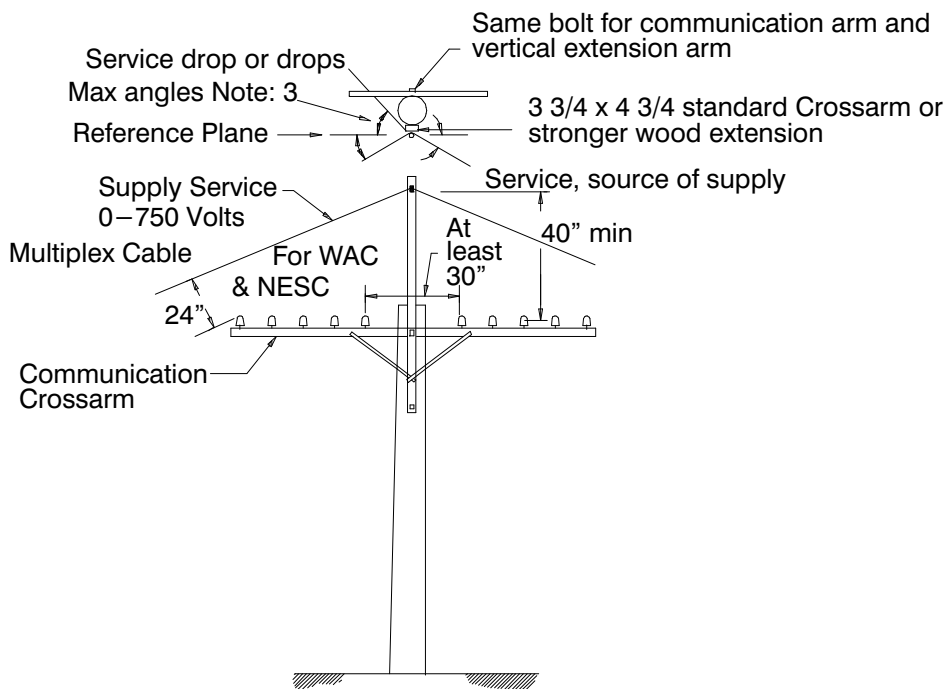

Figure 1 – Service Drop Contacts on Communications Poles

Notes:

1. Use pole top fixture when following conditions exist:
 - a. Not more than 2 branches to service
 - b. Span from supply pole to communication pole not over 100 Ft. and span from communication pole to house not over 100 ft.

**Distribution
Construction Standard**

Engineer (N. J. Johnson):
Distribution Engrg. (D. Horman):
Standards Services (M. Brimhall):

**Joint Use
Clearances, Low
Voltage Service Drops**

PACIFICORP
PACIFIC POWER UTAH POWER

31 May 93

EU 281
Page 1 of 2

EU 281

- c. Maximum size of service wire from communication pole to house is # 2 triplex.
- 2. Where conditions are more severe than shown by drawing or as limited by note 1, then each such case must be individually planned.
- 3. Angle of service crossing and service drop or drops to a plane normal to the alignment of the pole line shall not exceed 45 degrees.



Joint Use Clearances, Low Voltage Service Drops

Distribution Construction Standard

Engineer (N. J. Johnson):
Distribution Engr. (D. Horman):
Standards Services (M. Brimhall):

Joint Use—CATV on Poles

A. Scope

This specification details the clearances, locations and equipment involved in the installation of Community Antenna Television (CATV) auxiliary equipment on PacifiCorp poles.

B. General

1. CATV auxiliary equipment consists mainly of power supplies and separate service protection disconnects. An installation usually consists of a 120V service in conduit to a service disconnect, a metal cabinet with a 120V AC to 60V AC or DC power supply (batteries optional), and a return supply line (usually 1/2-inch coax) to the main CATV cable. An amplifier is usually supported on the CATV cable messenger at least 18 inches away from the pole. The return supply line terminates at the amplifier or other termination device suspended by the CATV messenger.
2. *CATV companies are Licensees and prior to installation, must make special written application to PacifiCorp to use space outside the normal communications space on PacifiCorp poles, as well as application to receive electrical service. PacifiCorp is concerned that additional equipment fastened to the pole not impair PacifiCorp's use of facilities nor lessen the margin of safety for our crews. In order that these conditions may be met, future installations must meet the requirements in Section C. PacifiCorp will reserve the right to decline electrical service until all requirements of this specification are met.*
3. Vertical pole space allocations for joint use distribution poles are given in PacifiCorp Standard EU 101.

C. Installation Requirements

1. All CATV equipment installations on company owned poles shall meet the requirements of the latest edition of the National Electrical Safety Code (NESC) applicable in Oregon, Idaho, Montana, Utah, and Wyoming; GO-95 in California; or the latest edition of the NESC applicable in Washington, except as superseded by the Washington Administrative Code (WAC).
2. CATV auxiliary equipment shall not be installed on poles having conduit risers or poles having gang-operated switches, capacitors, reclosers, or regulators. Any rearrangement of facilities required for auxiliary CATV equipment located outside the normal communication space allocation will be made at PacifiCorp's option and at the Licensee's expense.
3. The maximum size auxiliary equipment cabinet which may be installed on the pole, is limited to 26 inches wide by 26 inches high by 20 inches deep, exclusive of mounting bracket(s). The service disconnect, when attached to one end of the cabinet, is also excluded from these dimensions. No more than one such cabinet may be attached to a pole. A service disconnect may be installed separately above the cabinet, and if so installed, shall be on the same side of the pole. The service disconnect may be attached directly to the pole providing the dimensions of the service disconnect are no greater than 6 inches wide by 12 inches high by 6 inches deep.

**Distribution
Construction Standard**

© 2007 by PacifiCorp. All rights reserved.

Engineer (D. Asgharian): *DDA*
Standards Manager (G. Lyons): *GL*

**Joint Use—CATV on
Poles**



22 Mar 07

EU 401
Page 1 of 4

EU 401

If the auxiliary equipment is to be supplied by a portable generator during outage conditions, the service disconnect shall have a visible-break, double pole, double-throw switch to avoid back-feeding the utility service.

- Equipment mounted on a pole must not restrict the ability of an electric worker to climb past it. If the equipment cabinet is more than 12 inches in height, as shown in Figure 1, it must be mounted on offset brackets that provide a space for the electric worker to use a belt. This space must be at least 4 1/2 inches wide by 6 inches high, as shown in Figure 2. These brackets shall be installed with through bolts. The through bolt ends shall not protrude more than 1 inch beyond the nut on other side of the pole. Use of wood crossarms or plastic mounting brackets is not acceptable. All holes bored in PacifiCorp's poles shall be flooded with a 2 percent solution of copper naphthenate before bolt insertion. Any unused pole holes due to misdrilling or equipment removal shall be flooded and plugged with treated dowels.

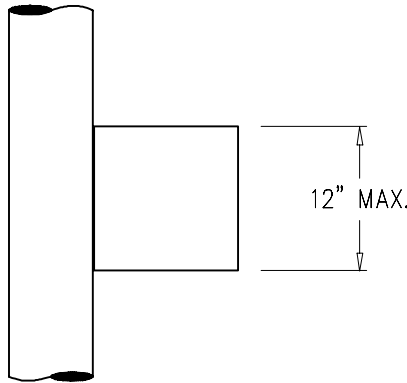

Figure 1 - Maximum Height of Directly Mounted Equipment Cabinet

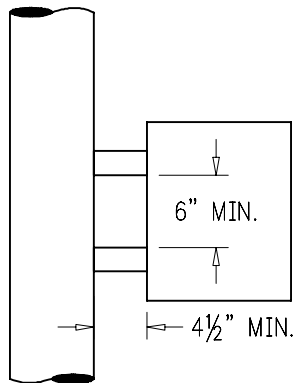

Figure 2 - Equipment Cabinet with Mounting Brackets

- The auxiliary cabinet and associated service equipment shall be installed in an orientation on the pole that allows a 30-inch-square minimum climbing space as shown in Figure 3. This climbing space shall extend vertically 48 inches above the uppermost portion and below the lowest portion of any installed auxiliary equipment.
- If the climbing space is rotated around the pole for continued climbing, the climbing spaces in different quadrants of the pole must overlap. The lowest point of any cabinet,

conduit, or cable shall be 12 feet above the ground. If any part of an enclosure overhangs a roadway shoulder, the minimum distance to the lowest portion shall be 15 feet. Enclosures overhanging roadways shall have at least a 16-foot clearance.

7. All work that is done above the joint use communications space shall be performed only by workers who are trained and qualified to work in the electric utility space, and have PacifiCorp authorization to perform the specific work. The electric service riser shall be provided and installed at the cost of the Licensee. The riser, as shown in Figure 4, shall be run in PVC Schedule 40, electrical grade conduit, attached to the pole at no greater than 30 inch intervals. A PVC service entrance fitting shall also be used. The return supply line from the cabinet to the main CATV cable position shall be covered with plastic or wooden molding, as appropriate, where the supply line is in contact with the pole (see Figure 3).

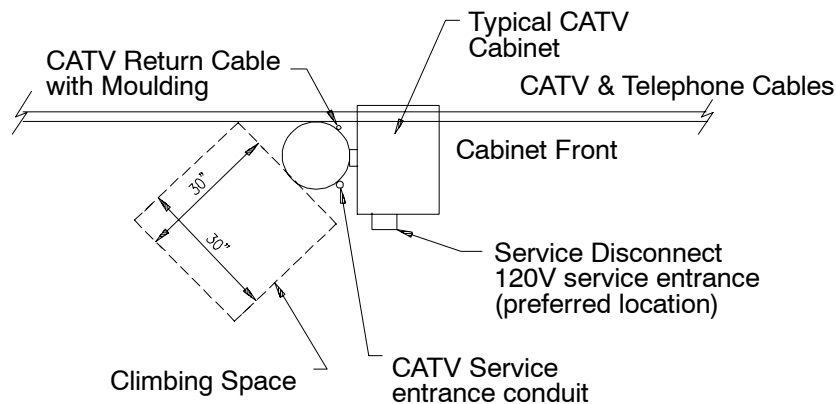

Figure 3 - Climbing Space

8. All metallic enclosures shall be effectively grounded. The minimum grounding conductor size shall be #6 AWG soft drawn copper. The enclosure grounding conductor shall be attached to the power system grounding conductor, if available, by means of a compression connector or other approved fitting. This connection shall be in the communications space only. If the pole ground is not available, the communication utility shall request the installation of a pole ground by PacifiCorp. The Licensee shall provide and install any or all of the above grounding material if it is not already existing at the pole (see Figure 4).
9. The communication utility shall not attach their guy wires to PacifiCorp's anchors unless explicit written permission is given for each specific location. Anchor rod auxiliary eyes are not permitted on PacifiCorp anchors. Additionally, all guy wires installed on PacifiCorp anchors to support communication utility's equipment or cable shall be insulated as defined by Rule 279A2a of the NESC, and in accordance with PacifiCorp standard practice. In addition to meeting code, this practice prevents galvanic corrosion of anchors. The insulator shall meet NESC flashover and strength requirements. If, by written permission, PacifiCorp allows the guy wire to be bonded at the pole, an insulator is still required that meets NESC strength requirements as stated in NESC Rules 279A3 and 279A1c.
10. All guy wires attached to the communication utility's own anchors shall meet NESC requirements.

EU 401

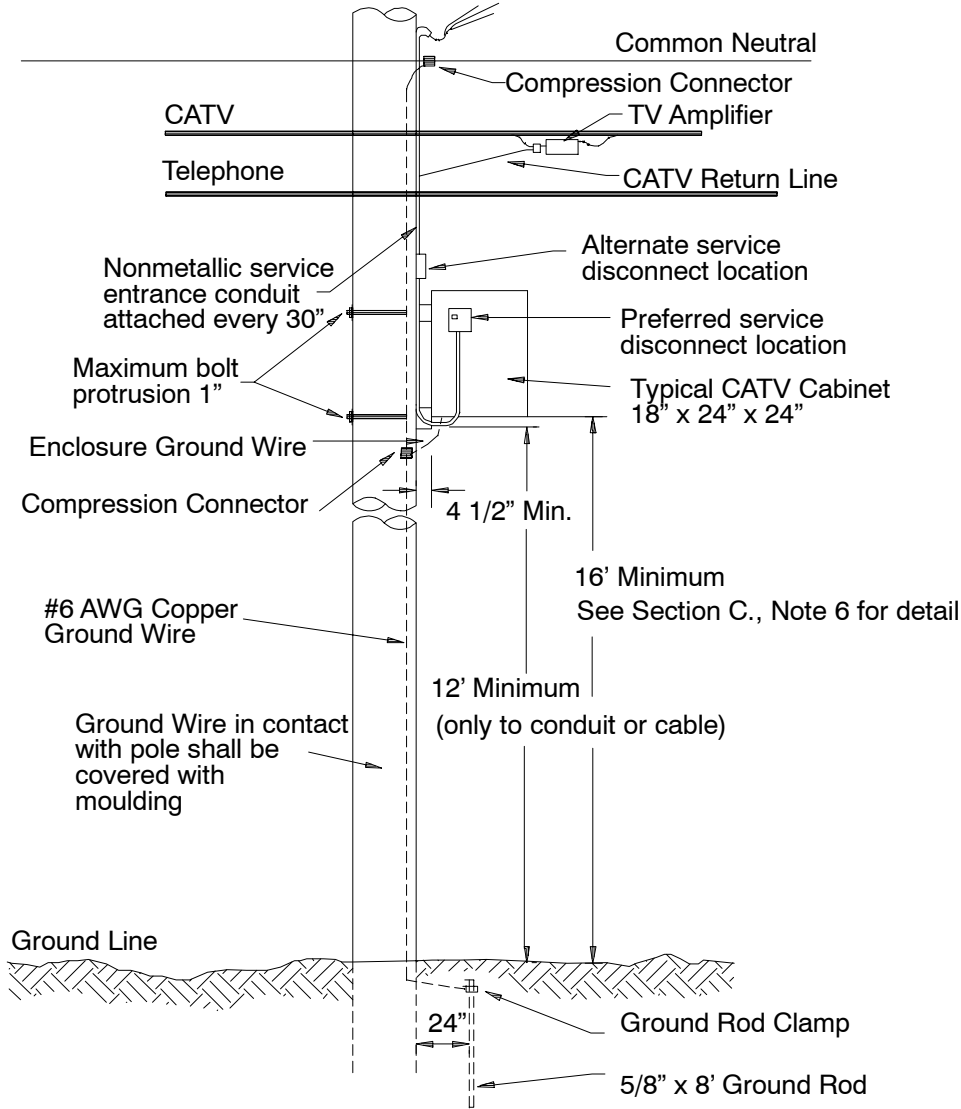

Figure 4 - Typical Installation of CATV Auxiliary Equipment with Grounding

