

NON-FIRM POWER PURCHASE AGREEMENT

BETWEEN

TESORO REFINING AND MARKETING COMPANY

AND

PACIFICORP

THIS AGREEMENT, entered into this ____ day of October 2012, is by and between Tesoro Refining and Marketing Company ("**Seller**") and PacifiCorp (individually, a "**Party**" and collectively, the "**Parties**").

RECITALS

A. Seller owns, operates, and maintains a natural gas-fired cogeneration facility for the generation of electric power located in Salt Lake City, Salt Lake County, Utah with a Nameplate Capacity Rating of 25.0-megawatts ("**MW**") ("**Facility**"); and

B. Seller intends to operate the Facility as a Qualifying Facility (as such term is defined in Section 3.2.6 below), commencing delivery under this Agreement at 00:00:01 MPT on January 1, 2013 ("**Initial Delivery Date**"); and

C. Seller estimates that the average annual Delivered Energy to be delivered by the Facility to PacifiCorp is 49,000 megawatt-hours (MWh) subject to any limitations created pursuant to any maintenance schedules in **Exhibit D** hereto; and

D. Seller desires to sell and PacifiCorp desires to purchase the Delivered Energy from the Facility in accordance with the terms and conditions of this Agreement; and

E. PacifiCorp shall sell and Seller shall purchase backup energy and capacity in accordance with the terms and conditions of a separate agreement between the parties modeled after Utah Schedule 31; and

F. The Agreement constitutes a "New QF Contract" under the PacifiCorp Interjurisdictional Cost Allocation Protocol ("**Protocol**"), previously filed with the Commission pursuant to a stipulation in Docket No. 02-035-04.

NOW, THEREFORE, the Parties mutually agree as follows:

SECTION 1: DEFINITIONS

When used in this Agreement, the following terms shall have the following meanings:

1.1 "**Billing Period**" means the time period between PacifiCorp's reading of its power purchase billing meters at the Facility in the normal course of PacifiCorp's business. Such periods typically range between twenty-seven (27) and thirty-four (34) days and may or may not coincide with calendar months.

1.2 "**Commission**" means the Public Service Commission of Utah.

1.3 "**Contract Year**" means a twelve (12) month period commencing 00:00:01 Mountain Prevailing Time ("MPT") on January 1 and ending at 24:00:00 MPT on December 31 of the calendar year 2013.

1.4 "**Delivered Energy**" is defined in Section 4.2 of this Agreement.

1.5 "**Facility**" means Seller's natural gas-fired cogeneration facility as described in the Recitals and **Exhibit A** of this Agreement.

1.6 "**Generation Interconnection Agreement**" means the generation interconnection agreements identified in **Exhibit C** entered into separately between Seller and PacifiCorp's transmission department, providing for the construction, operation, and maintenance of the interconnection facilities.

1.7 "**Initial Delivery Date**" means the earliest date Seller may deliver Delivered Energy under this Agreement, as set forth in Recital B.

1.8 "**Master Electric Service Agreement**" means the MASTER ELECTRIC SERVICE AGREEMENT entered into on the 18th day of December 2007, by and between PacifiCorp and Seller.

1.9 "**Nameplate Capacity Rating**" means the maximum capacity of the Facility, expressed in MW, when operated consistent with the manufacturer's recommended power factor and operating parameters, as set forth in **Exhibit A**.

1.10 "**Net Dependable Capacity**" means the maximum capacity the Facility can sustain over a specified period modified for seasonal limitations and reduced by the capacity required for station service or auxiliaries. For purposes of this Agreement, Net Dependable Capacity shall be the Nameplate Capacity Rating less the capacity required for station service or auxiliaries.

1.11 "**Net Output**" means all energy produced by the Facility, less station use and less transformation and transmission losses and other adjustments, if any.

1.12 "**On-Peak**" means the following:

October through April inclusive
7:00 a.m. to 11:00 p.m., Monday thru Friday, except holidays.
May through September inclusive
1:00 p.m. to 9:00 p.m., Monday thru Friday, except holidays.

Holidays include only New Year's Day, President's Day, Memorial Day, Independence Day, Pioneer Day, Labor Day, Thanksgiving Day, and Christmas Day. When a holiday falls on a Saturday or Sunday, the Friday before the holiday (if the holiday falls on a Saturday) or the Monday following the holiday (if the holiday falls on a Sunday) will be considered a holiday and consequently Off-Peak.

1.13 “**Off-Peak**” means those hours that are not On-Peak hours.

1.14 “**Point of Delivery**” means the high side of the generation step-up transformer(s) located at the Point of Interconnection between the Facility and PacifiCorp’s transmission system, as defined and specified in the Generation Interconnection Agreement and in **Exhibit B**.

1.15 “**Prime Rate**” means the then effective US Prime Rate as published in the Eastern print edition of the Wall Street Journal.

1.16 “**Prudent Electrical Practices**” means any of the practices, methods and acts engaged in or approved by a significant portion of the electrical utility industry or any of the practices, methods or acts, which, in the exercise of reasonable judgment in the light of the facts known at the time a decision is made, could have been expected to accomplish the desired result at the lowest reasonable cost consistent with reliability, safety and expedition. Prudent Electrical Practices is not intended to be limited to the optimum practice, method or act to the exclusion of all others, but rather to be a spectrum of possible practices, methods or acts.

1.17 “**Scheduled Maintenance Periods**” means those times, as reflected in **Exhibit D**, during which the Facility is anticipated to be shut down for routine maintenance with the advance notice to PacifiCorp as provided in Section 6.2.

SECTION 2: TERM

2.1 This Agreement shall become effective upon the occurrence of both: (1) execution by both Parties; and, (2) after approval by the Commission whereby the Commission determines that the prices to be paid for energy and capacity sold to PacifiCorp are just and reasonable and in the public interest (“**Effective Date**”). Energy delivery under this Agreement shall not commence prior to the Initial Delivery Date. For purposes of inter-jurisdictional cost allocation, this Agreement constitutes a “New QF Contract” under the PacifiCorp Inter-Jurisdictional Cost Allocation Protocol and, as such, the costs of those QF provisions are allocated as a system resource unless any portion of those costs exceed the cost

PacifiCorp would have otherwise incurred acquiring comparable resources. In that event, the Revised Protocol assigns those excess costs on a *situs* basis to the State of Utah. The rates, terms and conditions in this Agreement are in accordance with the rates, terms and conditions approved by the Commission in Docket No. 03-035-14 for purchases from qualifying facilities. In addition, for the purposes of inter-jurisdictional cost allocation, PacifiCorp represents that the costs of this Agreement do not exceed the costs PacifiCorp would have otherwise incurred acquiring resources in the market that are defined as “Comparable Resources” in Appendix A to the Inter-Jurisdictional Cost Allocation Revised Protocol. In the event that the Commission order approving this Agreement contains any condition, that is materially adverse to either Party, the Party adversely impacted by the condition may terminate this Agreement by providing the other Party notice within ninety (90) days of the entry of the Commission's order.

2.2. Unless terminated sooner as provided herein, this Agreement shall terminate at 24:00:00 MPT on December 31, 2013.

SECTION 3: REPRESENTATIONS AND WARRANTIES

3.1 PacifiCorp represents, covenants, and warrants to Seller that:

3.1.1 PacifiCorp is duly organized and validly existing under the laws of the State of Oregon.

3.1.2 PacifiCorp has the requisite corporate power and authority to enter into this Agreement and to perform according to the terms of this Agreement.

3.1.3 PacifiCorp has taken all corporate actions required to be taken by it to authorize the execution, delivery and performance of this Agreement and the consummation of the transactions contemplated hereby.

3.1.4 Subject to Commission approval, the execution and delivery of this Agreement does not contravene any provision of, or constitute a default under, any indenture, mortgage, or other material agreement binding on PacifiCorp or any valid order of any court, or any regulatory agency or other body having authority to which PacifiCorp is subject.

3.1.5 Subject to Commission approval, this Agreement is a valid and legally binding obligation of PacifiCorp, enforceable against PacifiCorp in accordance with its terms (except as the enforceability of this Agreement may be limited by bankruptcy, insolvency, bank moratorium or similar laws affecting creditors' rights generally and laws restricting the availability of equitable remedies and except as the enforceability of this Agreement may be subject to general principles of equity, whether or not such enforceability is considered in a proceeding at equity or in law).

3.2 Seller represents, covenants, and warrants to PacifiCorp that:

3.2.1 Seller is a Delaware corporation having a place of business within the State of Utah, in and about the town of Salt Lake City, Utah and located within the County of Salt Lake and is authorized to conduct its business in Utah.

3.2.2 Seller has the requisite power and authority to enter into this Agreement and to perform according to the terms hereof, including all required Generation Interconnection Agreements, and regulatory authority to make wholesale sales from the Facility.

3.2.3 Seller's directors and officers/other management have taken all actions required to authorize the execution, delivery and performance of this Agreement and the consummation of the transactions contemplated hereby.

3.2.4 The execution and delivery of this Agreement does not contravene any provision of, or constitute a default under, any indenture, mortgage, or other material agreement binding on Seller or any valid order of any court, or any regulatory agency or other body having authority to which Seller is subject.

3.2.5 Subject to Commission approval, this Agreement is a valid and legally binding obligation of Seller, enforceable against Seller in accordance with its terms (except as the enforceability of this Agreement may be limited by bankruptcy, insolvency, bank moratorium or similar laws affecting creditors' rights generally and laws restricting the availability of equitable remedies and except as the enforceability of this Agreement may be subject to general principles of equity, whether or not such enforceability is considered in a proceeding at equity or in law).

3.2.6 The Facility is and shall for the term of this Agreement continue to be a "**Qualifying Facility**" ("**QF**") as that term is defined in the version of 18 C.F.R. Part 292 in effect on the Effective Date. Seller has provided the appropriate QF certification, which may include a Federal Energy Regulatory Commission ("**FERC**") self-certification to PacifiCorp prior to PacifiCorp's execution of this Agreement. At any time during the term of this Agreement, PacifiCorp may, at Seller's sole expense, require Seller to provide PacifiCorp with a written legal opinion from an attorney in good standing in the state of Utah stating that the Facility is a QF and providing sufficient proof (including copies of all documents and data as PacifiCorp may request) demonstrating that Seller has maintained and will continue to maintain the Facility as a QF.

SECTION 4: DELIVERY OF POWER

4.1 Commencing on the Initial Delivery Date and continuing through the term of this Agreement, Seller shall sell and make available to PacifiCorp, and PacifiCorp shall purchase, the Delivered Energy from the Facility at the Point of Delivery as more particularly described in Section 4.2 hereto.

4.2 Commencing on the Initial Delivery Date, Seller shall have the option, but not the obligation, to provide and deliver all or a portion of the Net Output to PacifiCorp at the Point of Delivery. The amount of Net Output that Seller actually delivers to PacifiCorp at the Point of Delivery shall be referred to herein as the “**Delivered Energy**”. Seller shall not deliver energy at a rate exceeding the Nameplate Capacity Rating on an hour average basis and such excess energy, if any, shall not constitute Delivered Energy. PacifiCorp may accept energy delivered at a rate exceeding the Nameplate Capacity Rating, but shall not pay for it. PacifiCorp shall take all Delivered Energy at the Point of Delivery

4.3 Seller shall have no minimum delivery obligation, however Seller shall not sell Net Output to any entity other than PacifiCorp prior to the termination date specified in Section 2.2, *supra*. Seller may elect to self supply its own power usage at the same location as the Facility with any portion of Net Output instead of selling such Net Output to PacifiCorp as Delivered Energy under this Agreement. For purposes of this Agreement, PacifiCorp shall assume, unless given notice by Seller otherwise, that Seller desires to sell to PacifiCorp only those quantities of Net Output that exceed Seller’s own power usage at the same location.

4.4 Seller shall not increase the Nameplate Capacity Rating above that specified in Exhibit A or increase the ability of the Facility to deliver Net Output at a rate exceeding the Nameplate Capacity Rating through any means including, but not limited to, replacement of, modification of, or addition of existing equipment, except with the written consent of PacifiCorp. To the extent not otherwise provided in the Generation Interconnection Agreement, all costs associated with the modifications to PacifiCorp's interconnection facilities or electric system occasioned by or related to the interconnection of the Facility with PacifiCorp’s system, or any increase in generating capability of the Facility, or any increase of the Net Dependable Capacity from the Facility, shall be borne by Seller.

SECTION 5: PURCHASE PRICE

5.1 PacifiCorp shall pay to Seller the Total Payment per Billing Period for the Delivered Energy, calculated as follows:

Total Payment per Billing Period (\$) = Σ Total On-Peak Payment (\$) and Total Off-Peak Payment (\$).

Where:

Total On-Peak Payment (\$) = On-Peak Energy Price (\$/MWh) * Delivered Energy during On-Peak periods in each Billing Period (MWh) * Line Loss Factor

and

Total Off-Peak Payment (\$) = Off-Peak Energy Price (\$/MWh) * Delivered Energy during Off-Peak periods in each Billing Period (MWh) * Line Loss Factor

“On-Peak Energy Price” is the price set forth in Exhibit E for the applicable month in which the Delivered Energy was delivered.

“Off-Peak Energy Price” is the price set forth in Exhibit E for the applicable month in which the Delivered Energy was delivered.

The “Line Loss Factor” shall be 1.0413, and shall account for avoided line losses in accordance with the Commission approved methodology. This adjustment factor is based on a rate of 5.00% for real power losses for voltage of 46 kV or greater as set forth in Schedule 10 of PacifiCorp’s proposed revised Open Access Transmission Tariff (OATT) filed with the Federal Energy Regulatory Commission (FERC) on May 26, 2011 in Docket No. ER11-3643-000. In the event FERC approves a different line loss rate for real power losses for voltage of 46 kV or greater with an effective date during the term of this Agreement, PacifiCorp shall re-calculate the adjustment factor for avoided line losses consistent with the FERC approved line loss rate for real power losses for voltage of 46 kV or greater. The re-calculated adjustment factor for avoided line losses shall apply from the FERC effective date for such approved line loss rate.

5.2 The amount of Delivered Energy purchased by PacifiCorp in any Billing Period will be calculated as follows:

Delivered Energy (MWh) = the sum of the hourly kW out meter reads for meter LR 77614

Delivered Energy is the Net Output from the Facility less the internal retail energy usage at Seller’s Facility.

SECTION 6: OPERATION AND CONTROL

6.1 Seller shall operate and maintain the Facility in a safe manner in accordance with the Generation Interconnection Agreement, Prudent Electrical Practices and in accordance with the requirements of all applicable federal, state and local laws and the National Electric Safety Code as such laws and code may be amended from time to time. PacifiCorp shall have no obligation to purchase Net Output from the Facility to the extent the interconnection between the Facility and PacifiCorp’s electric system is disconnected, suspended or interrupted, in whole or in part, pursuant to the Generation Interconnection Agreement, or to the extent generation curtailment is required as a result of Seller’s non-compliance with the Generation Interconnection Agreement.

6.2 After the Initial Delivery Date, Seller may cease operation of the entire Facility or individual units, if applicable, for Scheduled Maintenance Periods not to exceed a total of sixty (60) days each Contract Year at such times as are provided in the monthly maintenance schedule set forth as Exhibit D.

6.3 If the Facility ceases operation for unscheduled maintenance, then as soon as is commercially reasonable, Seller shall notify PacifiCorp of the necessity of such unscheduled

maintenance, the time when such shutdown has occurred or will occur, and the anticipated duration of such shutdown. Seller shall take all reasonable measures and exercise its best efforts to avoid unscheduled maintenance, to limit the duration of such unscheduled maintenance, and to perform unscheduled maintenance during Off-Peak hours.

6.4 For each month commencing on the Initial Delivery Date, Seller shall provide PacifiCorp estimates of Delivered Energy to be delivered. Seller shall provide such estimates, and any changes thereto, to PacifiCorp on the first business day of the month preceding the month of the estimated delivery, or as soon thereafter as practicable. Seller shall provide such estimates and changes thereto to PacifiCorp's scheduling personnel per Section 22. Such estimates shall be based on the best information available. The Parties agree that the estimates are only estimates and, therefore, are not binding on Seller.

6.5 Seller does not guarantee availability of the Facility; however, Seller agrees to notify PacifiCorp of unplanned outages and will use reasonable commercial efforts to keep the Facility operating at highest availability for providing Delivered Energy to PacifiCorp.

SECTION 7: FUEL/MOTIVE FORCE

7.1 PacifiCorp shall have no obligation to procure or pay for any fuel that might be used in the operation of the Facility.

7.2 Seller shall procure and pay for gas in the natural gas marketplace and/or use gas generated by Seller and have it delivered to the Facility by a pipeline serving the Facility or, in the case of gas generated by Seller, by Seller's pipeline. The only pipeline currently available for marketplace gas is owned by Questar Gas Company and may be supplemented by subsequently constructed and operational pipeline capable of serving the Facility.

SECTION 8: [INTENTIONALLY LEFT BLANK]

SECTION 9: METERING

9.1 PacifiCorp shall design, furnish, install, own, inspect, test, maintain and replace all metering equipment required pursuant to the Generation Interconnection Agreement, and section 5.2 of this Agreement.

9.2 Metering shall be performed at the location and in the manner specified in the Generation Interconnection Agreement, and section 5.2 of this Agreement.

9.3 The metering equipment will be inspected, tested, repaired and replaced as provided in the Generation Interconnection Agreement. If any of the inspections or tests discloses Inaccurate Metering as defined in the Generation Interconnection Agreement, a correction will be made as provided in that agreement. Any correction in billings or payments

resulting from a correction in the meter records shall be settled and netted in accordance with Section 10 of this Agreement.

9.4 To the extent not otherwise provided in the Generation Interconnection Agreement, all PacifiCorp's costs relating to all metering equipment installed to accommodate Seller's Facility shall be borne by Seller.

SECTION 10: BILLINGS, COMPUTATIONS AND PAYMENTS

10.1 On or before the thirtieth (30th) day following the end of each Billing Period, PacifiCorp shall send to Seller payment for Seller's deliveries of Delivered Energy to PacifiCorp, together with computations supporting such payment. PacifiCorp shall offset any amounts then due to it under the Master Electric Service Agreement and may offset any such payment to reflect amounts owing from Seller to PacifiCorp pursuant to this Agreement, the Generation Interconnection Agreement, or any other agreement between the Parties or otherwise.

10.2 In the event that a Party disputes in good faith a portion of a bill or adjustment arising hereunder the disputing Party shall notify the other Party and pay the portion not in dispute when due. Seller and PacifiCorp shall seek to make a determination on any disputed amount within sixty (60) days after issuance of Seller's notice of dispute. Nothing herein shall be construed to preclude a Party from resorting to any remedy available at law or in equity.

10.3 Any amounts owing after the due date thereof, including amounts disputed under Section 10.2, shall bear interest at the Prime Rate plus two percent (2%) from the date due until paid; provided, however, that the interest rate shall at no time exceed the maximum rate allowed by applicable law.

SECTION 11: DEFAULT AND REMEDIES

11.1 The following events shall constitute defaults under this Agreement:

11.1.1 Failure of a Party to perform any material obligation imposed upon that Party by this Agreement (including but not limited to breach of Section 4.3 and failure to make a payment when due) or breach by a Party of a representation or warranty set forth in this Agreement, if such failure or breach is not cured within thirty (30) days following written notice;

11.1.2 Filing of a petition in bankruptcy by or against a Party if such petition is not withdrawn or dismissed within sixty (60) days after it is filed;

11.1.3 Seller's failure to cure any default under the Generation Interconnection Agreement within the time allowed for a cure under such agreement.

11.2 In the event of any default hereunder that is not cured in the manner provided for in the Agreement, the non-defaulting Party may terminate this agreement at its sole discretion by

delivering written notice to the other Party and may pursue any and all legal or equitable remedies provided by law or pursuant to this Agreement. The rights provided in this Section 11 are cumulative such that the exercise of one or more rights shall not constitute a waiver of any other rights.

11.3 In the event this Agreement is terminated because of Seller's default and Seller wishes to again sell Net Output to PacifiCorp following such termination, PacifiCorp in its sole discretion may require that Seller shall do so subject to the terms of this Agreement, including but not limited to the contract prices, until the termination date set forth in Section 2.2.

11.4 Upon an event of default or termination event under this Agreement, in addition to and not in limitation of any other right or remedy under contract or applicable law (including any right to set-off, counterclaim, or otherwise withhold payment), the non-defaulting Party may at its option set-off, against any amounts owed to the defaulting Party, any amounts owed by the defaulting Party under any contract or agreement between the Parties. The obligations of the Parties shall be deemed satisfied and discharged to the extent of any such set-off. The non-defaulting Party shall give the defaulting Party written notice of any set-off, but failure to give such notice shall not affect the validity of the set-off.

SECTION 12: INDEMNIFICATION, LIABILITY AND INSURANCE

12.1 Seller and PacifiCorp shall release, indemnify, protect and hold harmless each other as follows:

12.1.1 Seller shall release, indemnify, protect, and hold harmless PacifiCorp, its directors, officers, agents, representatives, successors, and assigns from and against any and all loss, claims, actions or suits, including costs and attorney's fees, resulting from, or arising out of or in any way connected with, the energy delivered by Seller hereunder to and at the Point of Delivery, including without limitation any loss, claim, action or suit, for or on account of injury, bodily or otherwise, to, or death of, persons, or for damage to, or destruction or economic loss of property belonging to PacifiCorp, Seller or others, excepting only such loss, claim, action or suit as may be caused solely by the fault or gross negligence of PacifiCorp, its directors, officers, employees, agents or representatives..

12.1.2 PacifiCorp shall release, indemnify, protect, and hold harmless Seller, its directors, officers, agents, representatives, successors, and assigns from and against any and all loss, claims, actions or suits, including costs and attorney's fees, resulting from, or arising out of or in any way connected with the energy delivered by Seller hereunder after the Point of Delivery, including without limitation any loss, claim, action or suit, for or on account of injury, bodily or otherwise, to, or death of, persons, or for damage to, or destruction or economic loss of property belonging to PacifiCorp, Seller or others, excepting only such loss, claim, action or suit as may be caused solely by the fault or gross negligence of Seller, its directors, officers, employees, agents or representatives.

12.2 Nothing in this Agreement shall be construed to create any duty to, any standard of care with reference to, or any liability to any person not a Party to this Agreement. No undertaking by one Party to the other under any provision of this Agreement shall constitute the dedication of that Party's system or any portion thereof to the other Party or to the public, nor affect the status of PacifiCorp as an independent public utility corporation or Seller as an independent individual or entity.

12.3 NEITHER PARTY SHALL BE LIABLE TO THE OTHER PARTY FOR SPECIAL, PUNITIVE, INDIRECT OR CONSEQUENTIAL DAMAGES, WHETHER ARISING FROM CONTRACT, TORT (INCLUDING NEGLIGENCE), STRICT LIABILITY, OR OTHERWISE.

12.4 Without limiting any liabilities or any other obligations of either Party, each Party shall comply with all applicable worker's compensation and employer's liability acts and shall furnish a certificate of insurance, in a form reasonably satisfactory to the other Party, prior to connection of the Facility to PacifiCorp's electric system.

12.5 Maintenance of Insurance Coverage. Without limiting any liabilities or any other obligations of Seller or PacifiCorp, each Party shall, prior to connection of the Facility to PacifiCorp's electric system, secure and continuously carry with insurers acceptable to PacifiCorp (which will not be unreasonably withheld), or self insure, the following insurance coverage:

12.5.1 Workers' Compensation (Statutory limit) and Employers' Liability insurance with a minimum limit of \$ 1,000,000 applicable to each accident/disease.

12.5.2 Commercial General Liability insurance, to include contractual liability, premises and operations, and broad form property damage, with a minimum single limit of \$1,000,000 each occurrence/\$2,000,000 general aggregate to protect against and from loss by reason of injury to persons or damage to property based upon and arising out of the activity under this Agreement.

12.5.3 Umbrella \ Excess Liability insurance with a single limit of at least \$10,000,000 each occurrence/aggregate, where applicable, to be in excess of the coverages and limits required in Employers' Liability insurance and Commercial General Liability insurance, above. A Party shall notify the other Party, and may be required to purchase additional limits of coverage, if at any time this minimum umbrella limit is not available during the term of this Agreement.

12.5.4 Commercial Automobile Liability, to include coverage for all owned and non-owned, hired or otherwise utilized vehicles with minimum combined single limit of \$1,000,000 per occurrence for bodily injury and property damage liability.

12.5.5 The Commercial General Liability and the Umbrella / Excess Liability policies required herein shall include i) provisions or endorsements naming the other Party, its Board of Directors, Officers and employees as additional insureds, and ii) cross liability coverage so that the insurance applies separately to each insured against whom

claim is made or suit is brought, even in instances where one insured claims against or sues another insured.

12.5.6 All liability policies required by this Agreement shall include provisions that such insurance is primary insurance with respect to the interests of the other Party and that any other insurance maintained by the other Party is excess and not contributory insurance with the insurance required hereunder, and provisions that such policies shall not be canceled or their limits of liability reduced without 1) ten (10) days prior written notice to the other Party if canceled for nonpayment of premium, or 2) thirty (30) days prior written notice to the other Party if canceled for any other reason. A certificate in a form satisfactory to the other Party certifying to the issuance of such insurance, shall be furnished to the other Party (Certificates sent to PacifiCorp shall be sent to the "All Notices" address, in Section 21.1, and shall state "Attn: Risk Management") . Commercial General Liability coverage written on a "claims-made" basis, if any, shall be specifically identified on the certificate. Insurance coverage provided on a "claims-made" basis shall be maintained by each Party for a minimum period of five (5) years after the completion of this Agreement.

12.5.7 Each Party, at its option, may self-insure for any or all of the coverage described above. In the event and to the extent a Party so elects, that Party shall advise the other Party in writing. For all such self-insurance maintained by a Party, that Party agrees to provide the other Party all the benefits that would otherwise be available and provided under an insurance policy in accordance with the requirements set forth above in this Section 12.5, including but not limited to defense of claims.

SECTION 13: FORCE MAJEURE

13.1 As used in this Agreement, "Force Majeure" or "an event of Force Majeure" means any cause beyond the reasonable control of the Seller or of PacifiCorp which, despite the exercise of due diligence, such Party is unable to prevent or overcome. By way of example, Force Majeure may include but is not limited to acts of God, flood, storms, wars, hostilities, civil strife, strikes, and other labor disturbances, earthquakes, fires, lightning, epidemics, sabotage, restraint by court order or other delay or failure in the performance as a result of any action or inaction on behalf of a public authority which is in each case (i) beyond the reasonable control of such Party, (ii) by the exercise of reasonable foresight such Party could not reasonably have been expected to avoid and (iii) by the exercise of due diligence, such Party shall be unable to prevent or overcome. Force Majeure, however, specifically excludes the cost or availability of fuel or motive force to operate the Facility or changes in market conditions that affect the price of energy or transmission. If either Party is rendered wholly or in part unable to perform its obligation under this Agreement because of an event of Force Majeure, both Parties shall be excused from whatever performance is affected by the event of Force Majeure, provided that:

13.1.1 the non-performing Party shall, within two (2) weeks after the occurrence of the Force Majeure, give the other Party written notice describing the particulars of the occurrence; and

13.1.2 the suspension of performance shall be of no greater scope and of no longer duration than is required by the Force Majeure; and

13.1.3 the non-performing Party uses its reasonable commercial efforts to remedy its inability to perform.

13.2 No obligations of either Party which arose before the Force Majeure causing the suspension of performance shall be excused as a result of the Force Majeure.

13.3 Neither Party shall be required to settle any strike, walkout, lockout or other labor dispute on terms which, in the sole judgment of the Party involved in the dispute, is contrary to the Party's best interests.

13.4 PacifiCorp may terminate the Agreement if Seller fails to remedy Seller's inability to perform, due to a Force Majeure event, within six months after the occurrence of the event.

SECTION 14: REGULATORY TERMINATION

PacifiCorp may terminate this Agreement if Seller (i) suspends operations at the Facility for more than thirty (30) days as the result of a regulatory or legal action by either the State of Utah or the United States Environmental Protection Agency which has become final without further appeal or (ii) loses its QF certification.

SECTION 15: SEVERAL OBLIGATIONS

Nothing contained in this Agreement shall ever be construed to create an association, trust, partnership or joint venture or to impose a trust or partnership duty, obligation or liability between the Parties. If Seller includes two or more parties, each such party shall be jointly and severally liable for Seller's obligations under this Agreement.

SECTION 16: CHOICE OF LAW

This Agreement shall be interpreted and enforced in accordance with the laws of the state of Utah, excluding any choice of law rules which may direct the application of the laws of another jurisdiction.

SECTION 17: PARTIAL INVALIDITY

It is not the intention of the Parties to violate any laws governing the subject matter of this Agreement. If any of the terms of the Agreement are finally held or determined to be invalid, illegal or void as being contrary to any applicable law or public policy, all other terms of the Agreement shall remain in effect. If any terms are finally held or determined to be invalid, illegal or void, the Parties shall enter into negotiations concerning the terms affected by such decision for the purpose of achieving conformity with requirements of any applicable law and the intent of the Parties to this Agreement.

SECTION 18: WAIVER

Any waiver at any time by either Party of its rights with respect to a default under this Agreement or with respect to any other matters arising in connection with this Agreement must be in writing, and such waiver shall not be deemed a waiver with respect to any subsequent default or other matter.

SECTION 19: GOVERNMENTAL JURISDICTION AND AUTHORIZATIONS

This Agreement is subject to the jurisdiction of those governmental agencies having control over either Party or this Agreement. PacifiCorp's compliance with the terms of this Agreement is conditioned on Seller's submission to PacifiCorp prior to the Initial Delivery Date and maintaining thereafter copies of all local, state and federal licenses, permits and other approvals as then may be required by law for the construction, operation and maintenance of the Facility.

SECTION 20: SUCCESSORS AND ASSIGNS

This Agreement and all of the terms hereof shall be binding upon and inure to the benefit of the respective successors and assigns of the Parties. No assignment hereof by either Party shall become effective without the written consent of the other Party being first obtained and such consent shall not be unreasonably withheld. Notwithstanding the foregoing, either Party may assign this Agreement without the other Party's consent to a lender as part of a financing transaction or as part of (a) a sale of all or substantially all of the assigning Party's assets, or (b) a merger, consolidation or other reorganization of the assigning Party.

SECTION 21: ENTIRE AGREEMENT

This Agreement supersedes all prior agreements, proposals, representations, negotiations, discussions or letters, whether oral or in writing, regarding PacifiCorp's purchase of Delivered Energy from the Facility commencing on the Initial Delivery date. No modification of this Agreement shall be effective unless it is in writing and signed by both Parties.

SECTION 22: NOTICES

22.1 All notices except as otherwise provided in this Agreement shall be in writing, shall be directed as follows and shall be considered delivered if delivered in person or when deposited in the U.S. Mail, postage prepaid by certified or registered mail and return receipt requested.

To PacifiCorp:

All Notices: Street: 825 NE Multnomah Street City: Portland, OR 97232 Attn: Contract Administration, Suite 600 Phone: (503) 813 - 5952 Facsimile: (503) 813 - 6291 Duns: 00-790-9013 Federal Tax ID Number: 93-0246090	Payments: Attn: Wholesale Sales PO Box 5504 Portland, OR 97228 Wire Transfer: To be provided by PacifiCorp to Tesoro in separate letter
Invoices: Attn: Back Office, Suite 600 Phone: (503) 813 - 5578 Facsimile: (503) 813 - 5580	Credit and Collections: Attn: Credit Manager, Suite 400 Phone: (503) 813 - 5684 Facsimile: (503) 813 - 5609
Scheduling: Attn: Resource Planning, Suite 600 Phone: (503) 813 - 6090 Facsimile: (503) 813 - 6265	With additional Notices of an Event of Default or Potential Event of Default to: Attn: Dean S. Brockbank, Esq. Phone: (801) 220-4568 Facsimile: (801) 220-3299

To Tesoro:

All Notices: Tesoro Refining and Marketing Company Attn: Procurement/Strategic Sourcing David Barge Mail Stop TX1-032 19100 Ridgewood Parkway San Antonio, TX 78259-1828 Telephone Number: (210) 626-7499 Fax: (210) 745-4453	And to: Tesoro Refining and Marketing Company Attn: Technical Manager Raymond Lahti 474 West 900 North Salt Lake City, UT 84103 Telephone Number: (801) 521-4871 Facsimile Number: (801) 521-4925
--	---

david.a.barge@tsocorp.com	
With a copy to: Tesoro Refining and Marketing Company Attn: Legal Department Mail Stop TX1-101 19100 Ridgewood Parkway San Antonio, TX 78259-1828 Telephone Number: (210) 626-4712 Facsimile Number: (210) 745-4659	Wire Transfer: To be provided by Tesoro to PacifiCorp in separate letter

22.2 The Parties may change the person to whom such notices are addressed, or their addresses, by providing written notices thereof in accordance with this Section 22.

SECTION 23: COUNTERPARTS

This Agreement may be executed in counterparts. Signed copies of such counterparts may be transmitted to the Parties via facsimile or electronic mail. Electronically transmitted signed counterparts shall have the same effect as originals as between the Parties.

SECTION 24: JURY TRIAL WAIVER

TO THE FULLEST EXTENT PERMITTED BY LAW, EACH OF THE PARTIES HERETO WAIVES ANY RIGHT IT MAY HAVE TO A TRIAL BY JURY IN RESPECT OF LITIGATION DIRECTLY OR INDIRECTLY ARISING OUT OF, UNDER OR IN CONNECTION WITH THIS AGREEMENT. EACH PARTY FURTHER WAIVES ANY RIGHT TO CONSOLIDATE ANY ACTION IN WHICH A JURY TRIAL HAS BEEN WAIVED WITH ANY OTHER ACTION IN WHICH A JURY TRIAL CANNOT BE OR HAS NOT BEEN WAIVED.

IN WITNESS WHEREOF, the Parties hereto have caused this Agreement to be executed in their respective names as of the Effective Date.

PACIFICORP

By: _____
Name: Bruce Griswold
Title: Director, Short-Term Origination

TESORO REFINING AND MARKETING COMPANY

By: _____
Name: David Kirshner
Title: SVP, Commercial

EXHIBIT A
DESCRIPTION OF SELLER'S FACILITY

Seller's Facility consists of two (2) gas fired generators manufactured by Solar Turbines with a total combined Nameplate Capacity Rating of 25,000kW. More specifically, the Facilities Description is Appendix D of the Generation Interconnection Facilities Agreement between PacifiCorp and Tesoro Refining and Marketing Company dated March 17, 2004.

Location of the Facility: The Facility is located in the vicinity of the Tesoro Refinery in Salt Lake County, Utah. The location is more particularly described as follows:

Beginning at a point North 24°22'53" West 27.45 feet from the Northeast Corner of Lot 32, Block 11, Lake View Subdivision: thence North 24°22'53" West 428.4 feet; thence Southwesterly along a curve to the left 226.39 feet ;thence South 0°01'01" West 16.5 feet; thence North 89°59'37" West 27 feet; South 24°22'53" East 210.7 feet: thence South 89°59'34" East 3.3 Feet; thence South 0°01'01" East 25 feet; thence North 89°59'34" West 28.15 feet; thence South 24°22'53" East 118 feet; thence South 89°59'34" East 170 feet; thence North 24°22'52" West 118 feet; Thence South 89°59'34" East 133.784 feet to the point of Beginning.

EXHIBIT B
POINT OF DELIVERY / PARTIES' INTERCONNECTION FACILITIES

Point of Delivery is generally described in the Generation Interconnection Facilities Agreement dated March 17, 2004, and in Appendix D to that agreement (copied below), as the "Point of Interconnection".

Appendix D
One-Line Diagram

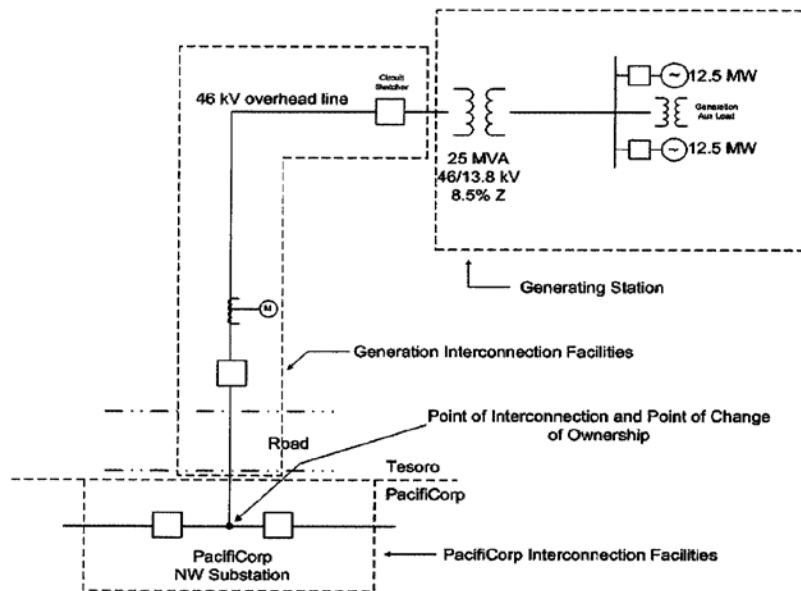

EXHIBIT C
REQUIRED FACILITY DOCUMENTS

GENERATION INTERCONNECTION FACILITIES AGREEMENT between
PACIFICORP and TESORO REFINING AND MARKETING COMPANY dated March
17, 2004

GENERATION INTERCONNECTION OPERATION AND MAINTENANCE
AGREEMENT between PACIFICORP and TESORO REFINING AND MARKETING
COMPANY dated July 23, 2004

PROOF OF COMPLIANCE WITH SECTION 12 OF THIS AGREEMENT

PROOF OF QF SELF-CERTIFICATION

EXHIBIT D
MONTHLY MAINTENANCE SCHEDULES

Scheduled Maintenance Periods are tentatively scheduled for:

Planned 6-day outage in May 2013
Planned 6-day outage in October 2013

Additionally, Tesoro plans for a two week outage for unit 2 in March and a two week outage for unit 1 in April as part of the Power Supply Reliability Improvement Project.

These schedules are tentative and may be adjusted by Seller with thirty (30) day written notice to PacifiCorp.

EXHIBIT E

PRICING (\$/MWh)

Month	On-Peak	Off-Peak
Jan-13	\$30.46	\$25.43
Feb-13	\$30.46	\$25.43
Mar-13	\$30.46	\$25.43
Apr-13	\$30.46	\$25.43
May-13	\$40.53	\$25.43
Jun-13	\$40.53	\$25.43
Jul-13	\$40.53	\$25.43
Aug-13	\$40.53	\$25.43
Sep-13	\$40.53	\$25.43
Oct-13	\$30.46	\$25.43
Nov-13	\$30.46	\$25.43
Dec-13	\$30.46	\$25.43