

VIA ETARIFF

December 13, 2022

The Honorable Kimberly D. Bose
Secretary
Federal Energy Regulatory Commission
888 First Street, N.E.
Washington, DC 20426

RE: *PacifiCorp*
Docket No. ER23-____-000

Dear Secretary Bose:

Pursuant to Federal Power Act Section 205, 16 U.S.C. § 824d, and Section 35.13 of the Rules and Regulations of the Federal Energy Regulatory Commission (“Commission” or “FERC”)¹ and Order No. 714² regarding electronic filing of tariff submittals, PacifiCorp hereby tenders for filing the following agreement:

Amended and Restated Project Construction Agreement Project Title: Tri-State Generation & Transmission Association Inc. / Pinto Substation Backup/Emergency Interconnection: (“Amended and Restated Construction Agreement”) between Tri-State Generation & Transmission Association Inc. (“Tri-State”), Empire Electric Association (“EEA”) and PacifiCorp, to be designated as Third Revised PacifiCorp Rate Schedule No. 754.

As discussed further below, PacifiCorp respectfully requests the Commission accept this Amended and Restated Construction Agreement effective on February 12, 2023.

1. Background and Reason for Filing

On November 12, 2020, Tri-State, EEA and PacifiCorp (collectively referred to herein as the “Parties”) entered into a Project Construction Agreement (“Construction Agreement”). EEA is a Tri-State member and takes wholesale service from Tri-State to provide distribution service to its consumers in southwestern Colorado and southeastern Utah. During maintenance and emergency conditions, Tri-State is unable to provide sub-Transmission level service to portions of EEA’s distribution system. On behalf of EEA, Tri-State requested PacifiCorp perform certain work to provide intermittent service during maintenance and/or emergency conditions. PacifiCorp agreed to perform the work required. On November 24, 2020, PacifiCorp filed the Construction Agreement as Rate Schedule No. 754, in Docket No. ER21-472. On January 4, 2021, the Commission accepted the Construction Agreement.³ On May 7, 2021, PacifiCorp filed the amended Construction Agreement as First Revised Rate Schedule No. 754, in Docket No. ER21-

¹ 18 C.F.R. § 35.13 (2021).

² *Electronic Tariff Filings*, Order No. 714, 124 FERC ¶ 61,270 (2008).

³ *PacifiCorp*, Letter Order, Docket No. ER21-472-000 (January 4, 2021).

1870. On June 14, 2021, the Commission accepted the amended Construction Agreement.⁴ On June 17, 2022, PacifiCorp filed an additional amended Construction Agreement as Second Revised Rate Schedule No. 754, in Docket No. ER22-2147. On August 12, 2022, the Commission accepted the amended Construction Agreement.⁵

The Construction Agreement was subsequently amended on December 6, 2022, and consequently, PacifiCorp is filing the amended Construction agreement with the Commission. The basis for the current revisions relates to Section 4.3 of the Construction Agreement, pursuant to which PacifiCorp sent a notice to UAMPS and EEA that the estimated Project costs will exceed the original estimated costs. Pursuant to Section 4.3, PacifiCorp requested that Tri-State approve and pay the additional estimated costs. On October 26, 2022, Tri-State notified PacifiCorp of its approval and agreement to pay the additional estimated costs. The Amended and Restated Construction Agreement reflects the new estimated costs. In particular, Sections 4.3 and 4.4 have been amended to reflect the new costs. Other minor revisions have been made, as well. . PacifiCorp respectfully requests that the Commission accept the Amended and Restated Construction Agreement, attached hereto, for filing.

2. Effective Date and Request for Waiver

PacifiCorp requests an effective date of February 12, 2023 for the Amended and Restated Construction Agreement. To the extent that any filing requirement in Part 35 of the Commission's regulations is not satisfied by this filing and the materials enclosed herewith, PacifiCorp respectfully requests waiver of such requirements.

3. Designation

PacifiCorp requests that the Amended and Restated Construction Agreement be designated as Third Revised PacifiCorp Rate Schedule No. 754.

4. Enclosures

The following enclosures are attached hereto:

Enclosure 1 Amended and Restated Construction Agreement between Tri-State, EEA and PacifiCorp, to be designated as Third Revised PacifiCorp Rate Schedule No. 754.

Enclosure 2 Redline of Third Revised Rate Schedule No. 754, as compared to Second Revised Rate Schedule No. 754.

5. Communications

All communications and correspondence regarding this filing should be forwarded to the following persons:

⁴ *PacifiCorp*, Letter Order, Docket No. ER21-1870-000 (June 14, 2021).

⁵ *PacifiCorp*, Letter Order, Docket No. ER22-2147-000 (August 12, 2022).

Matthew P. Loftus
Assistant General Counsel
PacifiCorp
825 N.E. Multnomah, Suite 2000
Portland, OR 97232
(503) 813-5620
Matthew.Loftus@PacifiCorp.com

Rick Vail
Vice President, Transmission
PacifiCorp
825 N.E. Multnomah, Suite 1600
Portland, OR 97232
(503) 813- 6938
Richard.Vail@PacifiCorp.com

6. Notice

Pursuant to 18 C.F.R. § 35.2(e), a copy of this filing is being served on the following:

Joel Bladow
Tri-State Generation and Transmission
Association, Inc.
1100 W. 116th Ave.
Westminster, CO 80234
jbladow@tristategt.org

Josh Dellinger
Empire Electric Association, Inc.
801 N. Broadway
PO Box K
Cortez, CO 81321-0676
Josh.dellinger@eea.coop

Utah Public Service Commission
Heber M. Wells Building
160 East 300 South
Salt Lake City, UT 84114
psc@utah.gov

7. Conclusion

For the reasons described herein, PacifiCorp respectfully requests the Commission accept this Revised Construction Agreement for filing with an effective date of February 12, 2023.

Respectfully submitted,



Matthew Loftus
Assistant General Counsel
PacifiCorp
825 N.E. Multnomah, Suite 1600
Portland, OR 97232
(503) 813-5620
Matthew.Loftus@PacifiCorp.com
Attorney for PacifiCorp

CLEAN

**AMENDED AND RESTATED PROJECT CONSTRUCTION AGREEMENT
PROJECT TITLE: TRI-STATE GENERATION AND TRANSMISSION ASSOCIATION
INC. / PINTO SUBSTATION BACKUP/EMERGENCY INTERCONNECTION**

This Amended and Restated Project Construction Agreement (“Agreement”) is made and entered into this 6th day of December, 2022, among Tri-State Generation and Transmission Association, Inc. (“Tri-State”), PacifiCorp and Empire Electric Association (“EEA”), for work to be performed by Tri-State, PacifiCorp and EEA at Pinto Substation. Hereinafter, Tri-State, PacifiCorp and EEA may be individually referred to as a “Party” or collectively referred to as the “Parties.”

RECITALS:

1. WHEREAS, PacifiCorp is a transmission provider which owns and operates certain facilities for the transmission of electric power and energy located in Utah; and
2. WHEREAS, Tri-State is a member cooperative which owns and operates certain facilities for the transmission of electric power and energy located in Colorado and surrounding areas; and
3. WHEREAS, EEA is a Tri-State member and takes wholesale service from Tri-State in order to provide distribution service to its consumers in southwestern Colorado and southeastern Utah; and
4. WHEREAS, during maintenance and/or emergency conditions Tri-State is unable to provide sub-transmission level service to portions of EEA’s distribution system; and
5. WHEREAS, on behalf of EEA, Tri-State has requested PacifiCorp to construct and interconnect one (1) 69 kV sub-transmission line bay and associated equipment and facilities and also to install, in compliance with PacifiCorp’s Meter Engineering Policy 500 for Third-Party Access to Revenue Class Meter Data, two (2) revenue meters (one primary, and one backup), (1) clone meter (to which Tri-State will have access to via cellular modem; PacifiCorp will own and maintain the cellular modem, and Tri-State will own and maintain the cellular modem’s SIM Card) and associated equipment at PacifiCorp’s Pinto Substation to provide intermittent service during maintenance and/or emergency conditions (collectively referred to as the “Project” and as further described in Exhibit B);
6. WHEREAS, in the original Project Construction Agreement dated November 12, 2020 (“Original Agreement”), the Amended Project Construction Agreement dated April 21, 2021 (“First Amended Agreement”), as well as the Amended and Restated Project Construction Agreement dated June 9, 2022, (“Second Amended Agreement”), Section 4.2 provides for the estimated cost of the Project. On October 21, 2022, pursuant to Section 4.3, PacifiCorp sent official notice to Tri-State and EEA that PacifiCorp determined that the estimated Project costs will exceed the

original estimated costs and requested that Tri-State approve and pay the additional estimated costs. On October 26, 2022, Tri-State notified PacifiCorp of its approval and agreement to pay the additional estimated costs. ; and

7. WHEREAS, the Parties have agreed to perform the work required to complete the Project.

NOW THEREFORE, in consideration of and subject to the mutual covenants contained herein, the Parties agree that this Agreement amends, supersedes, and completely restates the Original Agreement, the First Amended Agreement, and the Second Amended Agreement, and that the Original Agreement, the First Amended Agreement, and the Second Amended Agreement shall be of no further force and effect, as of the effective date established pursuant to Section 2, below, and that the parties further agree as follows:

1. DEFINITIONS.

Applicable Laws and Regulations shall mean all duly promulgated applicable federal, state and local laws, regulations, rules, ordinances, codes, decrees, judgments, directives, or judicial or administrative orders, permits and other duly authorized actions of any Governmental Authority.

Applicable Reliability Standards shall mean the requirements and guidelines of the North American Electric Reliability Corporation (“NERC”), the Applicable Reliability Council, and the Control Area of the Transmission System to which the Tri-State and/or EEA are directly interconnected.

Good Utility Practice shall mean any of the practices, methods and acts engaged in or approved by a significant portion of the electric utility industry during the relevant time period, or any of the practices, methods and acts which, in the exercise of reasonable judgment in light of the facts known at the time the decision was made, could have been expected to accomplish the desired result at a reasonable cost consistent with good business practices, reliability, safety and expedition. Good Utility Practice is not intended to be limited to the optimum practice, method, or act to the exclusion of all others, but rather to be acceptable practices, methods, or acts generally accepted in the region.

Governmental Authority shall mean any federal, state, local or other governmental regulatory or administrative agency, court, commission, department, board, or other governmental subdivision, legislature, rulemaking board, tribunal, or other governmental authority having jurisdiction over the Parties, their respective facilities, or the respective services they provide, and exercising or entitled to exercise any administrative, executive, police, or taxing authority or power; provided, however, that such term does not include Parties or any Affiliate thereof.

Project Costs shall mean the costs of facilities or portions of facilities that are constructed by PacifiCorp for the sole use/benefit of Tri-State and EEA.

2. TERM & TERMINATION. This Agreement shall be effective upon the later of the following: (1) the date of execution by the Parties, or (2) the effective date established by FERC

upon acceptance for filing. This Agreement shall terminate ninety (90) calendar days after the earliest of the following to occur:

- a. PacifiCorp's receipt of final payment of actual costs by Tri-State; or
- b. PacifiCorp's refund of overpayment to Tri-State, pursuant to Section 4 of this Agreement. In the event that neither an invoice nor a refund is required, this Agreement shall terminate ninety (90) calendar days following PacifiCorp's determination of actual costs after completion of construction; or
- c. Termination of the Agreement as provided in Section 4.3 of this Agreement (Authorization of Additional Amounts for Project Costs); or
- d. Termination of the Agreement as provided in Section 12 of this Agreement (Right to Stop Work).
- e. Notwithstanding the above, the termination of this Agreement is subject to acceptance by the FERC, which filing will be made by PacifiCorp in accordance with 18 C.F.R. § 35.15.

3. SCOPE AND PERFORMANCE OF WORK:

3.1. **Project Description and Scope.** As further described in Exhibit B, PacifiCorp shall design, procure, install, test and own the new 69 kV Monticello Rural line bay including a 69 kV circuit breaker, associated disconnect switches, deadend steel tower, 69 kV interchange metering, line protection, circuit breaker controls, and SCADA additions.

3.2. **PacifiCorp Responsibilities.** PacifiCorp agrees to design, procure, and install the Project as depicted in the attached Exhibit B, Estimated Scope of Work.

3.3. **EEA and Tri-State Responsibilities.** EEA and Tri-State agree to design, procure, and install other facilities as specified in the attached Exhibit B, Estimated Scope of Work.

3.4. **Performance Standards.** Each Party shall perform all its obligations under this Agreement in accordance with Applicable Laws and Regulations, Applicable Reliability Standards, and Good Utility Practice (as such terms are defined in this Agreement). To the extent a Party is required or prevented or limited in taking any action by such regulations and standards, such Party shall not be deemed to be in breach of this Agreement for compliance therewith.

4. OWNERSHIP/RESPONSIBILITY FOR COSTS:

4.1. Ownership. Each Party shall retain ownership and maintain equipment installed by the respective Party.

4.2. Estimated Costs. PacifiCorp's estimated cost for PacifiCorp's Scope of Work for the Project is \$1,547,062.

The estimated cost includes engineering, labor, materials, subcontracts, and applicable overheads. The cost estimate is based on the following assumptions: Estimate assumes no

exceptional site preparation will be needed; Estimate assumes project will be built during normal hours and will not require schedule compression or overtime; and Estimate assumes no new permitting, property, right of way or easements will be required by PacifiCorp.

4.3. Authorization of Additional Amounts for Project Costs. In the event that PacifiCorp determines the Project Costs may exceed \$1,547,062, PacifiCorp shall notify Tri-State and request that Tri-State provide written approval authorizing such additional amounts for Project Costs within thirty (30) days of such notice. PacifiCorp's obligation to proceed with the Project associated with such additional amounts shall be contingent upon receipt of such approval, along with a prepayment in such additional amount. Tri-State shall be responsible for such estimated costs, as increased pursuant to such written authorization. If Tri-State does not authorize such additional amounts within such thirty (30) day period, this Agreement shall terminate after PacifiCorp gives Tri-State written notice and an additional fifteen (15) days to cure. If Tri-State agrees to the cost increase, a modification to this Agreement will be prepared to indicate the additional funding amount.

4.4. Payment of Actual Costs. In consideration of the work to be performed by PacifiCorp, Tri-State agrees to pay the total estimated costs of \$1,547,062. As of the date of execution of this Agreement by the Parties, Tri-State has already paid to PacifiCorp \$1,047,400 for this Project, resulting in a balance due of \$499,662. All remaining funds owed by Tri-State to PacifiCorp for this Project will be submitted from Tri-State to PacifiCorp per this Section 4.4 upon execution of this Agreement.

Tri-State shall reimburse PacifiCorp for the actual cost to complete the work. Following completion of the Project, PacifiCorp shall determine its actual costs for the Project identified in the Scope of Work. PacifiCorp's actual costs shall include all direct costs plus applicable overheads. If the actual costs are more than the estimated costs, PacifiCorp will forward a copy of the actual costs to Tri-State along with an invoice for the additional amount within one hundred twenty (120) calendar days after completion of construction. If the actual costs are less than the estimated costs, PacifiCorp will forward a copy of the actual costs to Tri-State along with a refund to cover the overage within one hundred twenty (120) calendar days after completion of construction. Tri-State will have thirty (30) calendar days after receiving any invoice to make payment in full.

PacifiCorp shall keep accurate and complete accounting records in support of all cost billings and claims in accordance with generally accepted accounting principles. Upon request, PacifiCorp shall provide accounting records to Tri-State following completion of Project.

5. TAXES:

5.1. Tri-State's Payments Not Taxable. The Parties intend that all payments made by Tri-State to PacifiCorp for the installation of the Project shall be non-taxable, either as contributions to capital, or as an advance, in accordance with the Internal Revenue Code ("IRC") and any applicable state income tax laws and shall not be taxable as contributions in aid of construction or otherwise under the IRC and any applicable state income tax laws.

5.2. Indemnification for the Cost Consequences of Current Tax Liability Imposed Upon PacifiCorp. Notwithstanding Section 5.1, Tri-State shall protect, indemnify and hold harmless PacifiCorp from the cost consequences of any current tax liability imposed against PacifiCorp as the result of payments made by Tri-State to PacifiCorp under this Agreement for the Project, as well as any interest and penalties, other than interest and penalties attributable to any delay caused by PacifiCorp.

PacifiCorp shall not include a gross-up for the cost consequences of any current tax liability in the amounts it charges Tri-State under this Agreement unless (i) PacifiCorp has determined, in good faith, that the payments or property transfers made by Tri-State to PacifiCorp should be reported as income subject to taxation or (ii) any Governmental Authority directs PacifiCorp to report payments or property as income subject to taxation. Tri-State shall reimburse PacifiCorp for such costs on a fully grossed-up basis, in accordance with Section 5.3, within thirty (30) calendar days of receiving written notification from PacifiCorp of the amount due, including detail about how the amount was calculated.

5.3. Tax Gross-up Amount. Tri-State's liability for the cost consequences of any current tax liability under this Section 5 shall be calculated on a fully grossed-up basis. Except as may otherwise be agreed to by the parties, this means that Tri-State will pay PacifiCorp, in addition to the amount paid for the Project, an amount equal to (1) the current taxes imposed on PacifiCorp ("Current Taxes") on the excess of (a) the gross income realized by PacifiCorp as a result of payments made by Tri-State to PacifiCorp under this Agreement (without regard to any payments under this Article) (the "Gross Income Amount") over (b) the present value of future tax deductions for depreciation that will be available as a result of such payments (the "Present Value Depreciation Amount"), plus (2) an additional amount sufficient to permit PacifiCorp to receive and retain, after the payment of all Current Taxes, an amount equal to the net amount described in clause (1).

For this purpose, (i) Current Taxes shall be computed based on PacifiCorp's composite federal and state tax rates at the time the payments or property transfers are received and PacifiCorp will be treated as being subject to tax at the highest marginal rates in effect at that time (the "Current Tax Rate"), and (ii) the Present Value Depreciation Amount shall be computed by discounting PacifiCorp's anticipated tax depreciation deductions as a result of such payments by PacifiCorp's current weighted average cost of capital. Thus, the formula for calculating PacifiCorp's liability to PacifiCorp pursuant to this Article can be expressed as follows:

(Current Tax Rate x (Gross Income Amount – Present Value of Tax Depreciation)) / (1- Current Tax Rate).

5.4. Contests. In the event any Governmental Authority determines that PacifiCorp's receipt of payments or property constitutes income that is subject to taxation, PacifiCorp shall notify Tri-State, in writing, within thirty (30) calendar days of receiving notification of such determination by a Governmental Authority. Upon the timely written request by

TRI-STATE and at TRI-STATE's sole expense, PacifiCorp may appeal, protest, seek abatement of, or otherwise oppose such determination. Upon TRI-STATE's written request and sole expense, PacifiCorp may file a claim for refund with respect to any taxes paid under this Section 5.4, whether or not it has received such a determination. PacifiCorp reserves the right to make all decisions with regard to the prosecution of such appeal, protest, abatement or other contest, including the selection of counsel and compromise or settlement of the claim, but PacifiCorp shall keep TRI-STATE informed, shall consider in good faith suggestions from TRI-STATE about the conduct of the contest, and shall reasonably permit TRI-STATE or its representative to attend contest proceedings. TRI-STATE shall pay to PacifiCorp on a periodic basis, as invoiced by PacifiCorp, PacifiCorp's documented reasonable costs of prosecuting such appeal, protest, abatement or other contest. At any time during the contest, PacifiCorp may agree to a settlement either with TRI-STATE's consent or after obtaining written advice from nationally-recognized tax counsel, selected by PacifiCorp, but reasonably acceptable to TRI-STATE, that the proposed settlement represents a reasonable settlement given the hazards of litigation. TRI-STATE's obligation shall be based on the amount of the settlement agreed to by TRI-STATE, or if a higher amount, so much of the settlement that is supported by the written advice from nationally-recognized tax counsel selected under the terms of the preceding sentence. The settlement amount shall be calculated on a fully grossed-up basis to cover any related cost consequences of the current tax liability. Any settlement without TRI-STATE's consent or such written advice will relieve TRI-STATE from any obligation to indemnify Transmission Provider for the tax at issue in the contest.

5.5. Refund. In the event that (a) a private letter ruling is issued to PacifiCorp which holds that any amount paid by Tri-State to PacifiCorp under the terms of this Agreement is not subject to federal income taxation, (b) any legislative change or administrative announcement, notice, ruling or other determination makes it reasonably clear to PacifiCorp in good faith that any amount paid by Tri-State to PacifiCorp under the terms of this Agreement is not taxable to PacifiCorp, (c) any abatement, appeal, protest, or other contest results in a determination that any payments made by Tri-State to PacifiCorp are not subject to federal income tax, or (d) if PacifiCorp receives a refund from any taxing authority for any overpayment of tax attributable to any payment by Tri-State to PacifiCorp pursuant to this Agreement, PacifiCorp shall promptly refund to Tri-State the following:

- a. any payment made by Tri-State under this Section 5 for taxes that is attributable to the amount determined to be non-taxable, together with interest thereon;
- b. interest on any amounts paid by Tri-State to PacifiCorp for such taxes which PacifiCorp did not submit to the taxing authority, calculated in accordance with the methodology set forth in FERC's regulations at 18 C.F.R. § 35.19a(a)(2)(iii) from the date payment was made by Tri-State to the date PacifiCorp refunds such payment to Tri-State; and
- c. with respect to any such taxes paid by PacifiCorp, any refund or credit PacifiCorp receives or to which it may be entitled from any governmental authority, interest (or that portion thereof attributable to the payment described in clause (i), above)

owed to PacifiCorp for such overpayment of taxes (including any reduction in interest otherwise payable by PacifiCorp to any governmental authority resulting from an offset or credit); provided, however, that PacifiCorp will remit such amount promptly to Tri-State only after and to the extent that PacifiCorp has received a tax refund, credit or offset from any governmental authority for any applicable overpayment of income tax related to PacifiCorp's Project.

The intent of this provision is to leave the Parties, to the extent practicable, in the event that no taxes are due with respect to any payment for the Project hereunder, in the same position they would have been in had no such tax payments been made.

6. PROJECT SCHEDULE. The Parties have agreed to the Estimated Schedule and Milestones attached as Exhibit C, Estimated Schedule and Milestones, for the completion of the Project. All Project schedule milestones shall be good faith estimates of the time required to complete each Party's task at the time the schedule was developed.

7. STANDARD OF WORK. All work performed pursuant to this Agreement by a Party or their agents shall be performed in a good and workmanlike manner in accordance with Good Utility Practice and with any and all prudent and Applicable Reliability Standards and Applicable Laws and Regulations.

8. CHANGES IN SCOPE OF WORK. The Parties may at any time, in writing, mutually agree to changes and/or additions within the general scope of this Agreement or any amendment hereto, direct the omission of or variation in work, or alter the schedule. If such direction results in a material change in the amount or character of the work, an equitable adjustment in estimated costs and other such provisions of this Agreement as may be affected shall be made and this Agreement shall be modified in writing accordingly.

No change shall be binding upon the Parties until the Parties modify the Agreement in accordance with Section 30 of this Agreement. The issuance of information, advice, approvals, or instructions verbally or by an exchange of e-mail or in any other manner short of a writing executed by both Parties in accordance with Section 30 of this Agreement shall not constitute an authorized change order pursuant to this provision.

9. INSPECTION. Tri-State and EEA may, at their discretion and expense, inspect PacifiCorp's construction work of the Project in progress upon reasonable notice and with supervision by PacifiCorp. PacifiCorp may, at its discretion and Tri-State's expense, inspect Tri-State's and EEA's construction work of the Project in progress upon reasonable notice and with supervision by Tri-State or EEA depending on the part of the Project. EEA will provide applicable testing results to PacifiCorp as specified in the technical specifications.

10. TESTING. Before the new facilities required for the Project are energized, such new facilities shall be tested by PacifiCorp to ensure their safe and reliable operation in accordance with Good Utility Practice, all applicable FERC, NERC and Western Electricity Coordinating Council criteria and requirements, and all applicable federal, state, and local law, regulations, and requirements. If testing indicates that modifications are required, Tri-State shall bear the cost of

all such modifications in accordance with the cost allocation in Section 4 above, except to the extent that any such modifications are required as a result of PacifiCorp's or its agents' or its subcontractors' negligence, willful misconduct, or failure to comply with Good Utility Practice.

11. ACCESS. Each Party shall grant the other Parties reasonable escorted access to the Project consistent with such access rights as established in prior agreements between the Parties, provided that each Party provides reasonable notice and complies with the other Parties' safety and security rules. PacifiCorp acknowledges that the equipment to be installed by Tri-State is within the scope of the license contained in Exhibit 1 to the Master Installation, Operation and Maintenance Agreement for Metering Equipment between PacifiCorp and Tri-State identified as Contract No. TS-15-0160.

12. RIGHT TO STOP WORK. Tri-State and EEA collectively reserve the right, upon thirty (30) days advance written notice to PacifiCorp, to require PacifiCorp at any time to stop all work by PacifiCorp pursuant to this Agreement, provided that such stop-work order is the result of suspension or termination of the Project. Issuance of any such stop-work order shall terminate this Agreement. Upon issuance of any such stop-work order, Tri-State shall pay the Project Costs PacifiCorp has incurred prior to the stoppage of work, including, without limitation, the costs incurred in connection with the cancellation of third-party contracts and any cancellation costs for equipment that is already ordered for the Project.

13. GOVERNING LAW. Enforcement or interpretation of this Agreement shall be in the state court of the State of Utah, and all parties hereby submit to the jurisdiction of said court for the stated purpose. Furthermore, this Agreement shall be governed by and construed in accordance with the laws of the State of Utah.

14. NO PARTNERSHIP. This Agreement shall not be interpreted or construed to create an association, joint venture, agency relationship, or partnership between the Parties or to impose any partnership obligation or partnership liability upon either Party. Neither Party shall have any right, power or authority to enter into any agreement or undertaking for, or act on behalf of, or to act as or be an agent or representative of, or to otherwise bind, the other Party.

15. ASSIGNMENT. PacifiCorp may at any time assign its rights and delegate its obligations under this Agreement, in whole or in part, including, without limitation, transferring its rights and obligations under this Agreement to any: (i) affiliate; (ii) successor in interest with respect to the Project, or (iii) corporation or any other business entity in conjunction with a merger, consolidation or other business reorganization to which PacifiCorp is a party. Affiliate of PacifiCorp includes any entity in which Berkshire Hathaway, Inc. owns more than a 5% interest, over which Berkshire Hathaway exercises management control. Should such assignment take place, PacifiCorp will provide written notice to Tri-State. Tri-State and EEA shall not assign their rights, nor delegate their obligations, under this agreement without the prior written consent of PacifiCorp, which shall not be unreasonably withheld, and any attempted transfer in violation of this Section 15 shall be void; provided, however, that either Tri-State or EEA may mortgage, create or provide for a security interest in, or convey in trust, all or a part of its rights in this Agreement, under deeds of trust, mortgages, indentures or security agreements, as security for its present or future bonds or other obligations, without the need for notice to or consent of the PacifiCorp.

16. PROVISIONAL REMEDIES. A Party may seek provisional legal remedies, if in such Party's judgment such action is necessary to avoid irreparable damage or preserve the status quo.

17. ENTIRE CONTRACT. This Agreement constitutes the entire agreement between the Parties with respect to the subject matter hereof and there are no oral or written understandings, representations or commitments of any kind, express or implied, which are not expressly set forth herein.

18. NOTICES. Any correspondence regarding this work shall be directed to the appropriate party (or parties) as shown below:

Tri-State: Vice President, Transmission Engineering
Tri-State Generation and Transmission Association, Inc.
1100 W. 116th Ave.
Westminster, CO 80234

EEA: System Engineer
Empire Electric Association, Inc.
801 N. Broadway
P.O. Box K
Cortez, CO 81321-0676

PacifiCorp: Vice President, Transmission Services
825 NE Multnomah St., Suite 1600
Portland, OR 97232

19. PAYMENT. Payments shall be sent to:

US Mail Deliveries: PacifiCorp Transmission
P.O. Box 2757
Portland, OR 97208

Other Deliveries: PacifiCorp Transmission
Attn: Central Cashiers
825 NE Multnomah, Suite 550
Portland, OR 97232

20. INDEMNIFICATION. Except as otherwise provided in Section 21 below, each Party (each, an "Indemnifying Party") agrees to protect, defend, indemnify and hold harmless each of the other Parties, its officers, employees and agents (individually the "Indemnified Party" or collectively, the "Indemnified Parties") against and from any and all liability, suits, loss, damage, claims, actions, costs and expenses of any nature, including court costs and attorney's fees, even if such actions or claims are completely groundless, growing out of injury to or death of the Indemnifying Party or its subcontractors of any tier, its employees, agents or guests, or any other person or persons, or any and all destruction, loss or damage to property arising in any way in connection with, or related to, the Indemnifying Party's performance of any work or any of its

obligations under the Agreement, except as to injury to persons or damage to property on the work site to the extent caused by the sole negligence of any of the Indemnified Parties.

The indemnification obligations set forth herein shall not be limited by amounts or types of damages, compensation or benefits payable by or for the Indemnifying Party, contractors, subcontractors, sub-subcontractors, material suppliers or any person or entity for which any of them may be liable, under workers compensation acts, or any disability or employee benefit acts, in the event claims are asserted against persons or entities indemnified under this section by an employee of the Indemnifying Party, a contractor, a subcontractor, a sub-subcontractor, a material supplier, anyone directly or indirectly employed by any of them or anyone (or for whose acts they may be liable.)

Moreover, at the request of an Indemnified Party, the Indemnifying Party shall defend any action, claim or suit asserting a claim that might be covered by this indemnity. The Indemnifying Party shall pay all costs and expenses that may be incurred by an Indemnified Party in enforcing this indemnity and defense agreement, including attorney's fees actually paid by an Indemnified Party.

21. LIMITATION OF LIABILITY. Except as otherwise expressly provided in this Agreement, each Party's liability to the other Parties for any loss, cost, claim, injury, damage, liability, or expense, including reasonable attorney's fees, relating to or arising from any act or omission in its performance of this Agreement, shall be limited to the amount of direct damage actually incurred. In no event shall a Party be liable to another Party for any indirect, special, consequential, or punitive damages, except as specifically authorized by this Agreement.

22. FORCE MAJEURE. A Party shall not be subject to any liability or damages for inability to meet its obligations under this Agreement to the extent that such failure shall be due to causes beyond the control of the Party, including, but not limited to the following: (a) the operation and effect of any new or modified rules, regulations and orders promulgated by the Commission, any applicable state public utility commission, any municipality, or any governmental agency of the United States, or subdivision thereof (so long as the claiming party has not applied for or assisted in the application for, and has opposed where and to the extent reasonable, such government action); (b) restraining order, injunction or similar decree of any court; (c) any Force Majeure event.

Force Majeure shall mean any act of God, labor disturbance, act of the public enemy, war, insurrection, riot, fire, storm or flood, explosion, breakage or accident to machinery or equipment, any order, regulation or restriction imposed by governmental, military or lawfully established civilian authorities, or any other cause beyond a Party's control. A Force Majeure event does not include acts of negligence or intentional wrongdoing by the Party claiming Force Majeure.

Provided, the Party claiming Force Majeure shall make every reasonable attempt to remedy the cause thereof as diligently and expeditiously as possible. Except for the obligation to pay amounts owed when due, time periods for performance obligations of a Party herein shall be extended for the period during which Force Majeure was in effect.

23. SUCCESSORS. This Agreement will be binding upon the Parties and will inure to the

benefit of their respective successors.

24. SEVERABILITY. If any provision or portion of this Agreement shall for any reason be held or adjudged to be invalid or illegal or unenforceable by any court of competent jurisdiction or other Governmental Authority, (1) such portion or provision shall be deemed separate and independent, (2) the Parties shall negotiate in good faith to restore insofar as practicable the benefits to each Party that were affected by such ruling, and (3) the remainder of this Agreement shall remain in full force and effect.

25. WAIVER OF JURY TRIAL. TO THE FULLEST EXTENT PERMITTED BY LAW, EACH OF THE PARTIES HERETO WAIVES ANY RIGHT IT MAY HAVE TO A TRIAL BY JURY IN RESPECT OF LITIGATION DIRECTLY OR INDIRECTLY ARISING OUT OF, UNDER OR IN CONNECTION WITH THIS AGREEMENT. EACH PARTY FURTHER WAIVES ANY RIGHT TO CONSOLIDATE, OR TO REQUEST THE CONSOLIDATION OF, ANY ACTION IN WHICH A JURY TRIAL HAS BEEN WAIVED WITH ANY OTHER ACTION IN WHICH A JURY TRIAL CANNOT BE OR HAS NOT BEEN WAIVED.

26. MULTIPLE COUNTERPARTS. This Agreement may be executed in counterparts, each of which is deemed an original but all constitute one and the same instrument.

27. CONTRACTORS AND SUBCONTRACTORS. Nothing in this Agreement shall prevent Parties from utilizing the services of any third party contractor or subcontractor as it deems appropriate to perform its obligations under this Agreement; provided, however, that each Party shall require their third party contractor and subcontractor to comply with all applicable terms and conditions of this Agreement in providing such services and each Party shall remain primarily liable to the other Parties for the performance of such third party contractor and subcontractor.

28. NO THIRD-PARTY BENEFICIARIES. This Agreement is not intended to and does not create rights, remedies, or benefits of any character whatsoever in favor of any persons, corporations, associations, or entities other than the Parties, and the obligations herein assumed are solely for the use and benefit of the Parties, their successors in interest and where permitted, their assigns.

29. SURVIVAL. All payment obligations and liabilities incurred before the termination or expiration of this Agreement, will survive its termination or expiration.

30. MODIFICATIONS OR AMENDMENTS. No modification or amendment of any provision of this Agreement shall be effective unless set forth in a written document signed by authorized representative of the Parties. All modifications or amendments to this Agreement, if originally filed at FERC, will be filed by PacifiCorp and Tri-State as an amended and restated agreement.

31. RECITALS. The above stated recitals are incorporated into and made part of this Agreement by this reference to the same extent as if these recitals were set forth in full at this point.

32. WAIVER. Waiver of any right, privilege, claim, obligation, condition, or default shall be

in writing and signed by the waiving Party. No waiver by a Party of any breach of this Agreement shall be a waiver of any preceding or succeeding breach, and no waiver by a Party of any right under this Agreement shall be construed as a waiver of any other right.

33. DISPUTE RESOLUTION.

- 33.1. Submission. In the event a Party has a dispute, or asserts a claim, that arises out of or in connection with this Agreement, such Party (the "disputing Party") shall provide the other Parties with written notice of the dispute or claim ("Notice of Dispute"). Such dispute or claim shall be referred to a designated senior representative of each Party for resolution on an informal basis as promptly as practicable after receipt of the Notice of Dispute by the other Party. In the event the designated representatives are unable to resolve the claim or dispute through unassisted or assisted negotiations within thirty (30) calendar days of the other Parties' receipt of the Notice of Dispute, such claim or dispute may, upon mutual agreement of the Parties, be submitted to arbitration and resolved in accordance with the arbitration procedures set forth below. In the event the Parties do not agree to submit such claim or dispute to arbitration, each Party may exercise whatever rights and remedies it may have in a Federal court under Federal law.
- 33.2. Arbitration Procedures. Any arbitration initiated under these procedures shall be conducted before a single neutral arbitrator appointed by the Parties. If the Parties fail to agree upon a single arbitrator within ten (10) calendar days of the submission of the dispute to arbitration, each Party shall choose one arbitrator who shall sit on a three-member arbitration panel. The two arbitrators so chosen shall within twenty (20) calendar days select a third arbitrator to chair the arbitration panel. In either case, the arbitrators shall be knowledgeable in electric utility matters, including electric transmission and bulk power issues, and shall not have any current or past substantial business or financial relationships with any Party to the arbitration (except prior arbitration). The arbitrator(s) shall provide each of the Parties an opportunity to be heard and, except as otherwise provided herein, shall conduct the arbitration in accordance with the Commercial Arbitration Rules of the American Arbitration Association.
- 33.3. Arbitration Decisions. Unless otherwise agreed by the Parties, the arbitrator(s) shall render a decision within ninety (90) calendar days of appointment and shall notify the Parties in writing of such decision and the reasons therefore. The arbitrator(s) shall be authorized only to interpret and apply the provisions of this Agreement and shall have no power to modify or change any provision of this Agreement in any manner. The decision of the arbitrator(s) shall be final and binding upon the Parties, and judgment on the award may be entered in any court having jurisdiction. The decision of the arbitrator(s) may be appealed solely on the grounds that the conduct of the arbitrator(s), or the decision itself, violated the standards set forth in the Federal Arbitration Act or the Administrative Dispute Resolution Act. The final decision of the arbitrator must also be filed with FERC if it affects jurisdictional rates, terms, and conditions of service.

33.4. Costs. Each Party shall be responsible for its own costs incurred during the arbitration process and for the following costs, if applicable: (1) the cost of the arbitrator chosen by the Party to sit on the three member panel and one half of the cost of the third arbitrator chosen; or (2) one half the cost of the single arbitrator jointly chosen by the Parties.

IN WITNESS WHEREOF, the Parties hereto have entered into this Agreement effective as of the day and year first herein above written.

PACIFICORP

Rick Vail Digitally signed by Rick Vail
Date: 2022.12.06 05:56:40
-08'00'

Signature

Rick Vail
Printed Name of Signor

Vice President, Transmission
Title of Signor

12/06/2022
Date

TRI-STATE GENERATION AND TRANSMISSION ASSOCIATION, INC.

chris pink
chris pink (Nov 30, 2022 12:44 MST)

Signature

Chris Pink
Printed Name of Signor

Vice President, Transmission Engineering
Title of Signor

Nov 30, 2022
Date

EMPIRE ELECTRIC ASSOCIATION, INC.

Signature

Josh Dellinger
Printed Name of Signor

12-05-2022
Date

Exhibit A One-Line Diagram

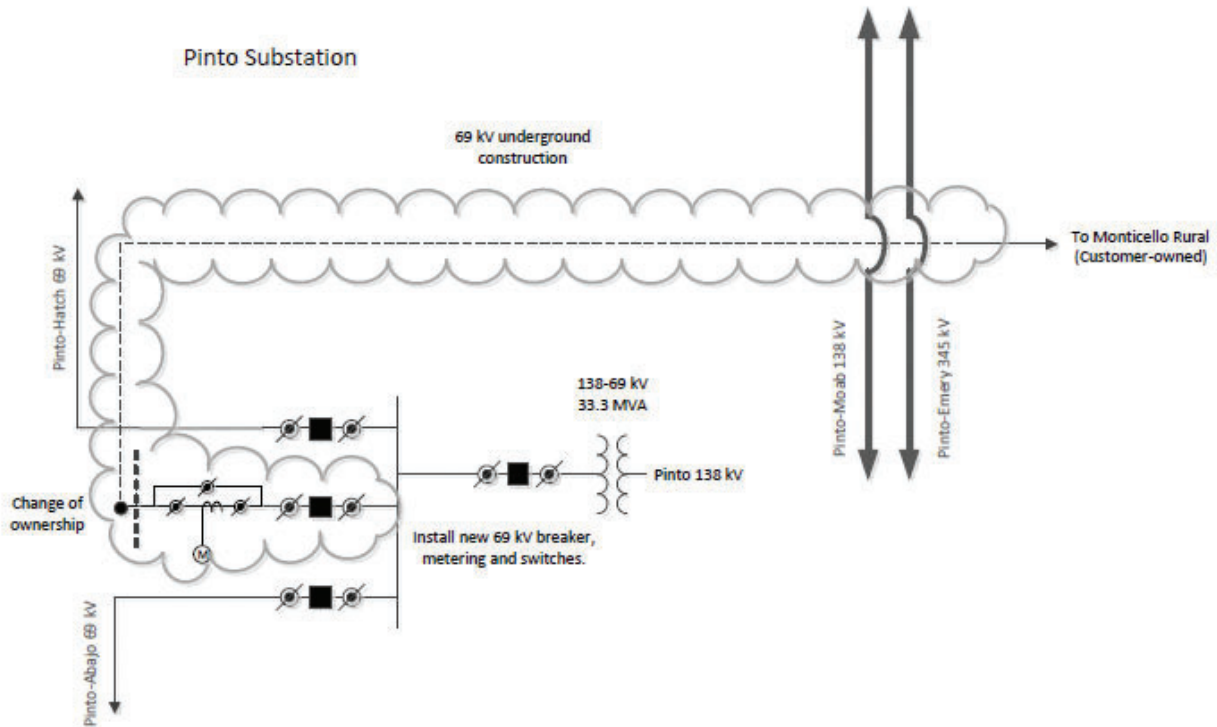

Exhibit B
Estimated Scope of Work

Equipment to be installed/constructed, responsibilities, and requirements under this exhibit may be adjusted upon mutual agreement by all Parties pursuant to project design outcomes.

At Tri-State's expense, PacifiCorp shall:

- Design, procure, construct, own and maintain the additional breaker bay in Pinto substation. This will include the installation of the following major equipment:
 1. (1) – 69 kV, circuit breaker
 2. (2) – 69 kV, switch, group operated
 3. (6) – 69 kV, switch, hook stick operated
 4. (3) – 69 kV, combined CT/VT metering unit of a high accuracy, extended range model type (0.15s B1.8, 1-200% I (rated) or higher).
 5. (3) – 69 kV, arrester
- Design, provide, and install a 69 kV breaker in the vacant bay on the Pinto 69 kV bus assembly.
- Design, provide, and install 69 kV metering on the line side of the breaker in compliance with PacifiCorp's Meter Engineering Policy 500 for Third-Party Access to Revenue Class Meter Data
- Expand the Pinto Substation to accommodate the installation of a substation outboard dead-end structure.
- Perform a CDEGS grounding analysis and modify ground grid as required.
- Modify the bus differential relay system for the connection to the EEA's load.
- Design, provide, install, and or modify the relays for the EEA's tie line.
- Procure and install communications equipment.
- Include the following data points into the Pinto substation RTU:
 1. Analogs:
 - a. MW
 - b. MV
 - c. Line Voltage A
 - d. Line Voltage B
 - e. Line Voltage C
 - f. Line Fault Location
 2. Status:
 - a. Breaker Status
- Design, procure and install 69 kV revenue metering equipment for the Project including two (2) revenue quality meters (primary and backup), test switch, instrument transformers, metering panels, junction box and secondary metering wire.
- Design, procure and install clone meter and cellular modem for Tri-State's meter data access, per PacifiCorp's Policy 500.
- Develop an Ethernet connection for retail sales and generation accounting via the MV-90 translation system.

- Review, and mitigate the design of those portions of the EEA sub-transmission line which reside on PacifiCorp property and on PacifiCorp right of way.
- Construction of the last span from the EEA underground riser structure to the Pinto Substation tower using PacifiCorp standard hardware supplied and standard conductor shield wire.
- Provide PacifiCorp standards as requested by Tri-State and/or EEA subject to PacifiCorp authorization.

At EEA's expense, EEA shall:

- Design, construct and own the 69 kV sub-transmission line from the point of interconnection and change of ownership at the Pinto Substation to EEA's Monticello substation.
- Provide and install conductor, shield wire and line hardware in sufficient quantities to allow the PacifiCorp to construct the last span of the EEA tie line from the EEA riser structure to the Pinto Substation dead end structure tower steel.
- Model, design, provide and install the sub-transmission line to avoid conflicts with the PacifiCorp facilities.
- Procure all necessary permits, property rights and/or the rights of way for the new Monticello-Pinto sub-transmission line.

Exhibit C
Estimated Schedule and Milestones

The estimated schedule and milestones are driven by the below timeframes which may be adjusted through the course of the Project. If there is a delay in any of the below activities, there will be, at a minimum, a day for day slip in the entire schedule. Any delays in the Project have the potential to affect the entire schedule.

| Milestones | Estimated Date |
|---|-----------------------|
| Tri-State Provision of Financial Security | December 1, 2020 |
| Transmission Provider Permitting and Property Design Support Commence | January 15, 2021 |
| EEA Acquired Property/Permits/ROW Complete | March 31, 2021 |
| Transmission Provider Acquired Property/Permits/ROW Complete | March 31, 2021 |
| Transmission Provider Engineering & Procurement Commences | January 15, 2021 |
| Interconnection Customers Design Information Provided | January 15, 2021 |
| Energy Imbalance Market Modeling Data Submittal | June 16, 2021 |
| Transmission Provider Engineering Design Complete | October 15, 2021 |
| Construction Begins | November 14, 2022 |
| Construction Complete | March 29, 2023 |
| EEA's Facilities Receive Load | April 14, 2023 |

MARKED

AMENDED AND RESTATED PROJECT CONSTRUCTION AGREEMENT
PROJECT TITLE: TRI-STATE GENERATION AND TRANSMISSION ASSOCIATION
INC. / PINTO SUBSTATION BACKUP/EMERGENCY INTERCONNECTION

This Amended and Restated Project Construction Agreement (“Agreement”) is made and entered into this 96th day of ~~June~~December, 2022, among Tri-State Generation and Transmission Association, Inc. (“Tri-State”), PacifiCorp and Empire Electric Association (“EEA”), for work to be performed by Tri-State, PacifiCorp and EEA at Pinto Substation. Hereinafter, Tri-State, PacifiCorp and EEA may be individually referred to as a “Party” or collectively referred to as the “Parties.”

RECITALS:

1. WHEREAS, PacifiCorp is a transmission provider which owns and operates certain facilities for the transmission of electric power and energy located in Utah; and
2. WHEREAS, Tri-State is a member cooperative which owns and operates certain facilities for the transmission of electric power and energy located in Colorado and surrounding areas; and
3. WHEREAS, EEA is a Tri-State member and takes wholesale service from Tri-State in order to provide distribution service to its consumers in southwestern Colorado and southeastern Utah; and
4. WHEREAS, during maintenance and/or emergency conditions Tri-State is unable to provide sub-transmission level service to portions of EEA’s distribution system; and
5. WHEREAS, on behalf of EEA, Tri-State has requested PacifiCorp to construct and interconnect one (1) 69 kV sub-transmission line bay and associated equipment and facilities and also to install, in compliance with PacifiCorp’s Meter Engineering Policy 500 for Third-Party Access to Revenue Class Meter Data, two (2) revenue meters (one primary, and one backup), (1) clone meter (to which Tri-State will have access to via cellular modem; PacifiCorp will own and maintain the cellular modem, and Tri-State will own and maintain the cellular modem’s SIM Card) and associated equipment at PacifiCorp’s Pinto Substation to provide intermittent service during maintenance and/or emergency conditions (collectively referred to as the “Project” and as further described in Exhibit B);
6. WHEREAS, in the original Project Construction Agreement dated November 12, 2020 (“Original Agreement”), ~~as well as the Amended Project Construction Agreement dated April 21, 2021 (“First Amended Agreement”), Exhibit B listed work to be done by Tri State at its own expense; however, the Parties subsequently determined that work is no longer needed and hereby amend Exhibit B to remove such work~~ as well as the Amended and Restated Project Construction

Agreement dated June 9, 2022, (“Second Amended Agreement”), Section 4.2 provides for the estimated cost of the Project. On October 21, 2022, pursuant to Section 4.3, PacifiCorp sent official notice to Tri-State and EEA that PacifiCorp determined that the estimated Project costs will exceed the original estimated costs and requested that Tri-State approve and pay the additional estimated costs. On October 26, 2022, Tri-State notified PacifiCorp of its approval and agreement to pay the additional estimated costs. ; and

7. WHEREAS, the Parties have agreed to perform the work required to complete the Project.

NOW THEREFORE, in consideration of and subject to the mutual covenants contained herein, the Parties agree that this Agreement amends, supersedes, and completely restates ~~both~~ the Original Agreement ~~and~~ the First Amended Agreement, and the Second Amended Agreement, and that the Original Agreement ~~and~~ the First Amended Agreement, and the Second Amended Agreement shall be of no further force and effect, as of the effective date established pursuant to Section 2, below, and that the parties further agree as follows:

1. DEFINITIONS.

Applicable Laws and Regulations shall mean all duly promulgated applicable federal, state and local laws, regulations, rules, ordinances, codes, decrees, judgments, directives, or judicial or administrative orders, permits and other duly authorized actions of any Governmental Authority.

Applicable Reliability Standards shall mean the requirements and guidelines of the North American Electric Reliability Corporation (“NERC”), the Applicable Reliability Council, and the Control Area of the Transmission System to which the Tri-State and/or EEA are directly interconnected.

Good Utility Practice shall mean any of the practices, methods and acts engaged in or approved by a significant portion of the electric utility industry during the relevant time period, or any of the practices, methods and acts which, in the exercise of reasonable judgment in light of the facts known at the time the decision was made, could have been expected to accomplish the desired result at a reasonable cost consistent with good business practices, reliability, safety and expedition. Good Utility Practice is not intended to be limited to the optimum practice, method, or act to the exclusion of all others, but rather to be acceptable practices, methods, or acts generally accepted in the region.

Governmental Authority shall mean any federal, state, local or other governmental regulatory or administrative agency, court, commission, department, board, or other governmental subdivision, legislature, rulemaking board, tribunal, or other governmental authority having jurisdiction over the Parties, their respective facilities, or the respective services they provide, and exercising or entitled to exercise any administrative, executive, police, or taxing authority or power; provided, however, that such term does not include Parties or any Affiliate thereof.

Project Costs shall mean the costs of facilities or portions of facilities that are constructed by PacifiCorp for the sole use/benefit of Tri-State and EEA.

2. **TERM & TERMINATION.** This Agreement shall be effective upon the later of the following: (1) the date of execution by the Parties, or (2) the effective date established by FERC upon acceptance for filing. This Agreement shall terminate ninety (90) calendar days after the earliest of the following to occur:

- a. PacifiCorp's receipt of final payment of actual costs by Tri-State; or
- b. PacifiCorp's refund of overpayment to Tri-State, pursuant to Section 4 of this Agreement. In the event that neither an invoice nor a refund is required, this Agreement shall terminate ninety (90) calendar days following PacifiCorp's determination of actual costs after completion of construction; or
- c. Termination of the Agreement as provided in Section 4.3 of this Agreement (Authorization of Additional Amounts for Project Costs); or
- d. Termination of the Agreement as provided in Section 12 of this Agreement (Right to Stop Work).
- e. Notwithstanding the above, the termination of this Agreement is subject to acceptance by the FERC, which filing will be made by PacifiCorp in accordance with 18 C.F.R. § 35.15.

3. **SCOPE AND PERFORMANCE OF WORK:**

3.1. **Project Description and Scope.** As further described in Exhibit B, PacifiCorp shall design, procure, install, test and own the new 69 kV Monticello Rural line bay including a 69 kV circuit breaker, associated disconnect switches, deadend steel tower, 69 kV interchange metering, line protection, circuit breaker controls, and SCADA additions.

3.2. **PacifiCorp Responsibilities.** PacifiCorp agrees to design, procure, and install the Project as depicted in the attached Exhibit B, Estimated Scope of Work.

3.3. **EEA and Tri-State Responsibilities.** EEA and Tri-State agree to design, procure, and install other facilities as specified in the attached Exhibit B, Estimated Scope of Work.

3.4. **Performance Standards.** Each Party shall perform all its obligations under this Agreement in accordance with Applicable Laws and Regulations, Applicable Reliability Standards, and Good Utility Practice (as such terms are defined in this Agreement). To the extent a Party is required or prevented or limited in taking any action by such regulations and standards, such Party shall not be deemed to be in breach of this Agreement for compliance therewith.

4. **OWNERSHIP/RESPONSIBILITY FOR COSTS:**

4.1. **Ownership.** Each Party shall retain ownership and maintain equipment installed

by the respective Party.

4.2. Estimated Costs. PacifiCorp's estimated cost for PacifiCorp's Scope of Work for the Project is ~~\$1,052,400~~1,547,062.

The estimated cost includes engineering, labor, materials, subcontracts, and applicable overheads. The cost estimate is based on the following assumptions: Estimate assumes no exceptional site preparation will be needed; Estimate assumes project will be built during normal hours and will not require schedule compression or overtime; and Estimate assumes no new permitting, property, right of way or easements will be required by PacifiCorp.

4.3. Authorization of Additional Amounts for Project Costs. In the event that PacifiCorp determines the Project Costs may exceed ~~\$1,052,400~~1,547,062, PacifiCorp shall notify Tri-State and request that Tri-State provide written approval authorizing such additional amounts for Project Costs within thirty (30) days of such notice. PacifiCorp's obligation to proceed with the Project associated with such additional amounts shall be contingent upon receipt of such approval, along with a prepayment in such additional amount. Tri-State shall be responsible for such estimated costs, as increased pursuant to such written authorization. If Tri-State does not authorize such additional amounts within such thirty (30) day period, this Agreement shall terminate after PacifiCorp gives Tri-State written notice and an additional fifteen (15) days to cure. If Tri-State agrees to the cost increase, a modification to this Agreement will be prepared to indicate the additional funding amount.

4.4. Payment of Actual Costs. In consideration of the work to be performed by PacifiCorp, Tri-State agrees to pay the total estimated costs of ~~\$1,052,400 within thirty (30) calendar days after the Effective Date of this Agreement~~1,547,062. As of the date of execution of this Agreement by the Parties, Tri-State has already paid to PacifiCorp \$1,047,400 for this Project, resulting in a balance due of \$499,662. ~~Any~~All remaining funds, ~~anticipated by Tri State to be approximately \$5,000,~~ owed by Tri-State to PacifiCorp for this Project will be submitted from Tri-State to PacifiCorp per this Section 4.4 upon execution of this Agreement.

Tri-State shall reimburse PacifiCorp for the actual cost to complete the work. Following completion of the Project, PacifiCorp shall determine its actual costs for the Project identified in the Scope of Work. PacifiCorp's actual costs shall include all direct costs plus applicable overheads. If the actual costs are more than the estimated costs, PacifiCorp will forward a copy of the actual costs to Tri-State along with an invoice for the additional amount within one hundred twenty (120) calendar days after completion of construction. If the actual costs are less than the estimated costs, PacifiCorp will forward a copy of the actual costs to Tri-State along with a refund to cover the overage within one hundred twenty (120) calendar days after completion of construction. Tri-State will have thirty (30) calendar days after receiving any invoice to make payment in full.

PacifiCorp shall keep accurate and complete accounting records in support of all cost

billings and claims in accordance with generally accepted accounting principles. Upon request, PacifiCorp shall provide accounting records to Tri-State following completion of Project.

5. TAXES:

5.1. Tri-State's Payments Not Taxable. The Parties intend that all payments made by Tri-State to PacifiCorp for the installation of the Project shall be non-taxable, either as contributions to capital, or as an advance, in accordance with the Internal Revenue Code ("IRC") and any applicable state income tax laws and shall not be taxable as contributions in aid of construction or otherwise under the IRC and any applicable state income tax laws.

5.2. Indemnification for the Cost Consequences of Current Tax Liability Imposed Upon PacifiCorp. Notwithstanding Section 5.1, Tri-State shall protect, indemnify and hold harmless PacifiCorp from the cost consequences of any current tax liability imposed against PacifiCorp as the result of payments made by Tri-State to PacifiCorp under this Agreement for the Project, as well as any interest and penalties, other than interest and penalties attributable to any delay caused by PacifiCorp.

PacifiCorp shall not include a gross-up for the cost consequences of any current tax liability in the amounts it charges Tri-State under this Agreement unless (i) PacifiCorp has determined, in good faith, that the payments or property transfers made by Tri-State to PacifiCorp should be reported as income subject to taxation or (ii) any Governmental Authority directs PacifiCorp to report payments or property as income subject to taxation. Tri-State shall reimburse PacifiCorp for such costs on a fully grossed-up basis, in accordance with Section 5.3, within thirty (30) calendar days of receiving written notification from PacifiCorp of the amount due, including detail about how the amount was calculated.

5.3. Tax Gross-up Amount. Tri-State's liability for the cost consequences of any current tax liability under this Section 5 shall be calculated on a fully grossed-up basis. Except as may otherwise be agreed to by the parties, this means that Tri-State will pay PacifiCorp, in addition to the amount paid for the Project, an amount equal to (1) the current taxes imposed on PacifiCorp ("Current Taxes") on the excess of (a) the gross income realized by PacifiCorp as a result of payments made by Tri-State to PacifiCorp under this Agreement (without regard to any payments under this Article) (the "Gross Income Amount") over (b) the present value of future tax deductions for depreciation that will be available as a result of such payments (the "Present Value Depreciation Amount"), plus (2) an additional amount sufficient to permit PacifiCorp to receive and retain, after the payment of all Current Taxes, an amount equal to the net amount described in clause (1).

For this purpose, (i) Current Taxes shall be computed based on PacifiCorp's composite federal and state tax rates at the time the payments or property transfers are received and PacifiCorp will be treated as being subject to tax at the highest marginal rates in effect at

that time (the "Current Tax Rate"), and (ii) the Present Value Depreciation Amount shall be computed by discounting PacifiCorp's anticipated tax depreciation deductions as a result of such payments by PacifiCorp's current weighted average cost of capital. Thus, the formula for calculating PacifiCorp's liability to PacifiCorp pursuant to this Article can be expressed as follows:

(Current Tax Rate x (Gross Income Amount – Present Value of Tax Depreciation)) / (1-Current Tax Rate).

5.4. Contests. In the event any Governmental Authority determines that PacifiCorp's receipt of payments or property constitutes income that is subject to taxation, PacifiCorp shall notify Tri-State, in writing, within thirty (30) calendar days of receiving notification of such determination by a Governmental Authority. Upon the timely written request by TRI-STATE and at TRI-STATE's sole expense, PacifiCorp may appeal, protest, seek abatement of, or otherwise oppose such determination. Upon TRI-STATE's written request and sole expense, PacifiCorp may file a claim for refund with respect to any taxes paid under this Section 5.4, whether or not it has received such a determination. PacifiCorp reserves the right to make all decisions with regard to the prosecution of such appeal, protest, abatement or other contest, including the selection of counsel and compromise or settlement of the claim, but PacifiCorp shall keep TRI-STATE informed, shall consider in good faith suggestions from TRI-STATE about the conduct of the contest, and shall reasonably permit TRI-STATE or its representative to attend contest proceedings. TRI-STATE shall pay to PacifiCorp on a periodic basis, as invoiced by PacifiCorp, PacifiCorp's documented reasonable costs of prosecuting such appeal, protest, abatement or other contest. At any time during the contest, PacifiCorp may agree to a settlement either with TRI-STATE's consent or after obtaining written advice from nationally-recognized tax counsel, selected by PacifiCorp, but reasonably acceptable to TRI-STATE, that the proposed settlement represents a reasonable settlement given the hazards of litigation. TRI-STATE's obligation shall be based on the amount of the settlement agreed to by TRI-STATE, or if a higher amount, so much of the settlement that is supported by the written advice from nationally-recognized tax counsel selected under the terms of the preceding sentence. The settlement amount shall be calculated on a fully grossed-up basis to cover any related cost consequences of the current tax liability. Any settlement without TRI-STATE's consent or such written advice will relieve TRI-STATE from any obligation to indemnify Transmission Provider for the tax at issue in the contest.

5.5. Refund. In the event that (a) a private letter ruling is issued to PacifiCorp which holds that any amount paid by Tri-State to PacifiCorp under the terms of this Agreement is not subject to federal income taxation, (b) any legislative change or administrative announcement, notice, ruling or other determination makes it reasonably clear to PacifiCorp in good faith that any amount paid by Tri-State to PacifiCorp under the terms of this Agreement is not taxable to PacifiCorp, (c) any abatement, appeal, protest, or other contest results in a determination that any payments made by Tri-State to PacifiCorp are not subject to federal income tax, or (d) if PacifiCorp receives a refund from any taxing authority for any overpayment of tax attributable to any payment by

Tri-State to PacifiCorp pursuant to this Agreement, PacifiCorp shall promptly refund to Tri-State the following:

- a. any payment made by Tri-State under this Section 5 for taxes that is attributable to the amount determined to be non-taxable, together with interest thereon;
- b. interest on any amounts paid by Tri-State to PacifiCorp for such taxes which PacifiCorp did not submit to the taxing authority, calculated in accordance with the methodology set forth in FERC's regulations at 18 C.F.R. § 35.19a(a)(2)(iii) from the date payment was made by Tri-State to the date PacifiCorp refunds such payment to Tri-State; and
- c. with respect to any such taxes paid by PacifiCorp, any refund or credit PacifiCorp receives or to which it may be entitled from any governmental authority, interest (or that portion thereof attributable to the payment described in clause (i), above) owed to PacifiCorp for such overpayment of taxes (including any reduction in interest otherwise payable by PacifiCorp to any governmental authority resulting from an offset or credit); provided, however, that PacifiCorp will remit such amount promptly to Tri-State only after and to the extent that PacifiCorp has received a tax refund, credit or offset from any governmental authority for any applicable overpayment of income tax related to PacifiCorp's Project.

The intent of this provision is to leave the Parties, to the extent practicable, in the event that no taxes are due with respect to any payment for the Project hereunder, in the same position they would have been in had no such tax payments been made.

6. PROJECT SCHEDULE. The Parties have agreed to the Estimated Schedule and Milestones attached as Exhibit C, Estimated Schedule and Milestones, for the completion of the Project. All Project schedule milestones shall be good faith estimates of the time required to complete each Party's task at the time the schedule was developed.

7. STANDARD OF WORK. All work performed pursuant to this Agreement by a Party or their agents shall be performed in a good and workmanlike manner in accordance with Good Utility Practice and with any and all prudent and Applicable Reliability Standards and Applicable Laws and Regulations.

8. CHANGES IN SCOPE OF WORK. The Parties may at any time, in writing, mutually agree to changes and/or additions within the general scope of this Agreement or any amendment hereto, direct the omission of or variation in work, or alter the schedule. If such direction results in a material change in the amount or character of the work, an equitable adjustment in estimated costs and other such provisions of this Agreement as may be affected shall be made and this Agreement shall be modified in writing accordingly.

No change shall be binding upon the Parties until the Parties modify the Agreement in accordance with Section 30 of this Agreement. The issuance of information, advice, approvals, or instructions verbally or by an exchange of e-mail or in any other manner short of a writing executed by both

Parties in accordance with Section 30 of this Agreement shall not constitute an authorized change order pursuant to this provision.

9. INSPECTION. Tri-State and EEA may, at their discretion and expense, inspect PacifiCorp's construction work of the Project in progress upon reasonable notice and with supervision by PacifiCorp. PacifiCorp may, at its discretion and Tri-State's expense, inspect Tri-State's and EEA's construction work of the Project in progress upon reasonable notice and with supervision by Tri-State or EEA depending on the part of the Project. EEA will provide applicable testing results to PacifiCorp as specified in the technical specifications.

10. TESTING. Before the new facilities required for the Project are energized, such new facilities shall be tested by PacifiCorp to ensure their safe and reliable operation in accordance with Good Utility Practice, all applicable FERC, NERC and Western Electricity Coordinating Council criteria and requirements, and all applicable federal, state, and local law, regulations, and requirements. If testing indicates that modifications are required, Tri-State shall bear the cost of all such modifications in accordance with the cost allocation in Section 4 above, except to the extent that any such modifications are required as a result of PacifiCorp's or its agents' or its subcontractors' negligence, willful misconduct, or failure to comply with Good Utility Practice.

11. ACCESS. Each Party shall grant the other Parties reasonable escorted access to the Project consistent with such access rights as established in prior agreements between the Parties, provided that each Party provides reasonable notice and complies with the other Parties' safety and security rules. PacifiCorp acknowledges that the equipment to be installed by Tri-State is within the scope of the license contained in Exhibit 1 to the Master Installation, Operation and Maintenance Agreement for Metering Equipment between PacifiCorp and Tri-State identified as Contract No. TS-15-0160.

12. RIGHT TO STOP WORK. Tri-State and EEA collectively reserve the right, upon thirty (30) days advance written notice to PacifiCorp, to require PacifiCorp at any time to stop all work by PacifiCorp pursuant to this Agreement, provided that such stop-work order is the result of suspension or termination of the Project. Issuance of any such stop-work order shall terminate this Agreement. Upon issuance of any such stop-work order, Tri-State shall pay the Project Costs PacifiCorp has incurred prior to the stoppage of work, including, without limitation, the costs incurred in connection with the cancellation of third-party contracts and any cancellation costs for equipment that is already ordered for the Project.

13. GOVERNING LAW. Enforcement or interpretation of this Agreement shall be in the state court of the State of Utah, and all parties hereby submit to the jurisdiction of said court for the stated purpose. Furthermore, this Agreement shall be governed by and construed in accordance with the laws of the State of Utah.

14. NO PARTNERSHIP. This Agreement shall not be interpreted or construed to create an association, joint venture, agency relationship, or partnership between the Parties or to impose any partnership obligation or partnership liability upon either Party. Neither Party shall have any right, power or authority to enter into any agreement or undertaking for, or act on behalf of, or to act as or be an agent or representative of, or to otherwise bind, the other Party.

15. ASSIGNMENT. PacifiCorp may at any time assign its rights and delegate its obligations under this Agreement, in whole or in part, including, without limitation, transferring its rights and obligations under this Agreement to any: (i) affiliate; (ii) successor in interest with respect to the Project, or (iii) corporation or any other business entity in conjunction with a merger, consolidation or other business reorganization to which PacifiCorp is a party. Affiliate of PacifiCorp includes any entity in which Berkshire Hathaway, Inc. owns more than a 5% interest, over which Berkshire Hathaway exercises management control. Should such assignment take place, PacifiCorp will provide written notice to Tri-State. Tri-State and EEA shall not assign their rights, nor delegate their obligations, under this agreement without the prior written consent of PacifiCorp, which shall not be unreasonably withheld, and any attempted transfer in violation of this Section 15 shall be void; provided, however, that either Tri-State or EEA may mortgage, create or provide for a security interest in, or convey in trust, all or a part of its rights in this Agreement, under deeds of trust, mortgages, indentures or security agreements, as security for its present or future bonds or other obligations, without the need for notice to or consent of the PacifiCorp.

16. PROVISIONAL REMEDIES. A Party may seek provisional legal remedies, if in such Party's judgment such action is necessary to avoid irreparable damage or preserve the status quo.

17. ENTIRE CONTRACT. This Agreement constitutes the entire agreement between the Parties with respect to the subject matter hereof and there are no oral or written understandings, representations or commitments of any kind, express or implied, which are not expressly set forth herein.

18. NOTICES. Any correspondence regarding this work shall be directed to the appropriate party (or parties) as shown below:

Tri-State: Senior Manager Transmission Engineering and Construction
Tri-State Generation and Transmission Association, Inc.
1100 W. 116th Ave.
Westminster, CO 80234

EEA: System Engineer
Empire Electric Association, Inc.
801 N. Broadway
P.O. Box K
Cortez, CO 81321-0676

PacifiCorp: Vice President, Transmission Services
825 NE Multnomah St., Suite 1600
Portland, OR 97232

19. PAYMENT. Payments shall be sent to:

US Mail Deliveries: PacifiCorp Transmission
P.O. Box 2757

Portland, OR 97208

Other Deliveries: PacifiCorp Transmission
Attn: Central Cashiers
825 NE Multnomah, Suite 550
Portland, OR 97232

20. INDEMNIFICATION. Except as otherwise provided in Section 21 below, each Party (each, an “Indemnifying Party”) agrees to protect, defend, indemnify and hold harmless each of the other Parties, its officers, employees and agents (individually the “Indemnified Party” or collectively, the “Indemnified Parties”) against and from any and all liability, suits, loss, damage, claims, actions, costs and expenses of any nature, including court costs and attorney’s fees, even if such actions or claims are completely groundless, growing out of injury to or death of the Indemnifying Party or its subcontractors of any tier, its employees, agents or guests, or any other person or persons, or any and all destruction, loss or damage to property arising in any way in connection with, or related to, the Indemnifying Party’s performance of any work or any of its obligations under the Agreement, except as to injury to persons or damage to property on the work site to the extent caused by the sole negligence of any of the Indemnified Parties.

The indemnification obligations set forth herein shall not be limited by amounts or types of damages, compensation or benefits payable by or for the Indemnifying Party, contractors, subcontractors, sub-subcontractors, material suppliers or any person or entity for which any of them may be liable, under workers compensation acts, or any disability or employee benefit acts, in the event claims are asserted against persons or entities indemnified under this section by an employee of the Indemnifying Party, a contractor, a subcontractor, a sub-subcontractor, a material supplier, anyone directly or indirectly employed by any of them or anyone (or for whose acts they may be liable.)

Moreover, at the request of an Indemnified Party, the Indemnifying Party shall defend any action, claim or suit asserting a claim that might be covered by this indemnity. The Indemnifying Party shall pay all costs and expenses that may be incurred by an Indemnified Party in enforcing this indemnity and defense agreement, including attorney’s fees actually paid by an Indemnified Party.

21. LIMITATION OF LIABILITY. Except as otherwise expressly provided in this Agreement, each Party's liability to the other Parties for any loss, cost, claim, injury, damage, liability, or expense, including reasonable attorney's fees, relating to or arising from any act or omission in its performance of this Agreement, shall be limited to the amount of direct damage actually incurred. In no event shall a Party be liable to another Party for any indirect, special, consequential, or punitive damages, except as specifically authorized by this Agreement.

22. FORCE MAJEURE. A Party shall not be subject to any liability or damages for inability to meet its obligations under this Agreement to the extent that such failure shall be due to causes beyond the control of the Party, including, but not limited to the following: (a) the operation and effect of any new or modified rules, regulations and orders promulgated by the Commission, any applicable state public utility commission, any municipality, or any governmental agency of the

United States, or subdivision thereof (so long as the claiming party has not applied for or assisted in the application for, and has opposed where and to the extent reasonable, such government action); (b) restraining order, injunction or similar decree of any court; (c) any Force Majeure event.

Force Majeure shall mean any act of God, labor disturbance, act of the public enemy, war, insurrection, riot, fire, storm or flood, explosion, breakage or accident to machinery or equipment, any order, regulation or restriction imposed by governmental, military or lawfully established civilian authorities, or any other cause beyond a Party's control. A Force Majeure event does not include acts of negligence or intentional wrongdoing by the Party claiming Force Majeure.

Provided, the Party claiming Force Majeure shall make every reasonable attempt to remedy the cause thereof as diligently and expeditiously as possible. Except for the obligation to pay amounts owed when due, time periods for performance obligations of a Party herein shall be extended for the period during which Force Majeure was in effect.

23. SUCCESSORS. This Agreement will be binding upon the Parties and will inure to the benefit of their respective successors.

24. SEVERABILITY. If any provision or portion of this Agreement shall for any reason be held or adjudged to be invalid or illegal or unenforceable by any court of competent jurisdiction or other Governmental Authority, (1) such portion or provision shall be deemed separate and independent, (2) the Parties shall negotiate in good faith to restore insofar as practicable the benefits to each Party that were affected by such ruling, and (3) the remainder of this Agreement shall remain in full force and effect.

25. WAIVER OF JURY TRIAL. TO THE FULLEST EXTENT PERMITTED BY LAW, EACH OF THE PARTIES HERETO WAIVES ANY RIGHT IT MAY HAVE TO A TRIAL BY JURY IN RESPECT OF LITIGATION DIRECTLY OR INDIRECTLY ARISING OUT OF, UNDER OR IN CONNECTION WITH THIS AGREEMENT. EACH PARTY FURTHER WAIVES ANY RIGHT TO CONSOLIDATE, OR TO REQUEST THE CONSOLIDATION OF, ANY ACTION IN WHICH A JURY TRIAL HAS BEEN WAIVED WITH ANY OTHER ACTION IN WHICH A JURY TRIAL CANNOT BE OR HAS NOT BEEN WAIVED.

26. MULTIPLE COUNTERPARTS. This Agreement may be executed in counterparts, each of which is deemed an original but all constitute one and the same instrument.

27. CONTRACTORS AND SUBCONTRACTORS. Nothing in this Agreement shall prevent Parties from utilizing the services of any third party contractor or subcontractor as it deems appropriate to perform its obligations under this Agreement; provided, however, that each Party shall require their third party contractor and subcontractor to comply with all applicable terms and conditions of this Agreement in providing such services and each Party shall remain primarily liable to the other Parties for the performance of such third party contractor and subcontractor.

28. NO THIRD-PARTY BENEFICIARIES. This Agreement is not intended to and does not create rights, remedies, or benefits of any character whatsoever in favor of any persons, corporations, associations, or entities other than the Parties, and the obligations herein assumed are solely for the use and benefit of the Parties, their successors in interest and where permitted, their assigns.

29. SURVIVAL. All payment obligations and liabilities incurred before the termination or expiration of this Agreement, will survive its termination or expiration.

30. MODIFICATIONS OR AMENDMENTS. No modification or amendment of any provision of this Agreement shall be effective unless set forth in a written document signed by authorized representative of the Parties. All modifications or amendments to this Agreement, if originally filed at FERC, will be filed by PacifiCorp and Tri-State as an amended and restated agreement.

31. RECITALS. The above stated recitals are incorporated into and made part of this Agreement by this reference to the same extent as if these recitals were set forth in full at this point.

32. WAIVER. Waiver of any right, privilege, claim, obligation, condition, or default shall be in writing and signed by the waiving Party. No waiver by a Party of any breach of this Agreement shall be a waiver of any preceding or succeeding breach, and no waiver by a Party of any right under this Agreement shall be construed as a waiver of any other right.

33. DISPUTE RESOLUTION.

33.1. Submission. In the event a Party has a dispute, or asserts a claim, that arises out of or in connection with this Agreement, such Party (the "disputing Party") shall provide the other Parties with written notice of the dispute or claim ("Notice of Dispute"). Such dispute or claim shall be referred to a designated senior representative of each Party for resolution on an informal basis as promptly as practicable after receipt of the Notice of Dispute by the other Party. In the event the designated representatives are unable to resolve the claim or dispute through unassisted or assisted negotiations within thirty (30) calendar days of the other Parties' receipt of the Notice of Dispute, such claim or dispute may, upon mutual agreement of the Parties, be submitted to arbitration and resolved in accordance with the arbitration procedures set forth below. In the event the Parties do not agree to submit such claim or dispute to arbitration, each Party may exercise whatever rights and remedies it may have in a Federal court under Federal law.

33.2. Arbitration Procedures. Any arbitration initiated under these procedures shall be conducted before a single neutral arbitrator appointed by the Parties. If the Parties fail to agree upon a single arbitrator within ten (10) calendar days of the submission of the dispute to arbitration, each Party shall choose one arbitrator who shall sit on a three-member arbitration panel. The two arbitrators so chosen shall within twenty (20) calendar days select a third arbitrator to chair the

arbitration panel. In either case, the arbitrators shall be knowledgeable in electric utility matters, including electric transmission and bulk power issues, and shall not have any current or past substantial business or financial relationships with any Party to the arbitration (except prior arbitration). The arbitrator(s) shall provide each of the Parties an opportunity to be heard and, except as otherwise provided herein, shall conduct the arbitration in accordance with the Commercial Arbitration Rules of the American Arbitration Association.

33.3. Arbitration Decisions. Unless otherwise agreed by the Parties, the arbitrator(s) shall render a decision within ninety (90) calendar days of appointment and shall notify the Parties in writing of such decision and the reasons therefore. The arbitrator(s) shall be authorized only to interpret and apply the provisions of this Agreement and shall have no power to modify or change any provision of this Agreement in any manner. The decision of the arbitrator(s) shall be final and binding upon the Parties, and judgment on the award may be entered in any court having jurisdiction. The decision of the arbitrator(s) may be appealed solely on the grounds that the conduct of the arbitrator(s), or the decision itself, violated the standards set forth in the Federal Arbitration Act or the Administrative Dispute Resolution Act. The final decision of the arbitrator must also be filed with FERC if it affects jurisdictional rates, terms, and conditions of service.

33.4. Costs. Each Party shall be responsible for its own costs incurred during the arbitration process and for the following costs, if applicable: (1) the cost of the arbitrator chosen by the Party to sit on the three member panel and one half of the cost of the third arbitrator chosen; or (2) one half the cost of the single arbitrator jointly chosen by the Parties.

IN WITNESS WHEREOF, the Parties hereto have entered into this Agreement effective as of the day and year first herein above written.

PACIFICORP

TRI-STATE GENERATION AND TRANSMISSION ASSOCIATION, INC.

/s/ Rick Vail

/s/ ~~Mary Ann Zehr~~ Chris Pink

Signature

Signature

Rick Vail

~~Mary Ann Zehr~~ Chris Pink

Printed Name of Signor

Printed Name of Signor

~~VP~~ Vice President, Transmission
~~Business Strategy~~ Engineering

Vice President, Transmission

Title of Signor

Title of Signor

12/06/2022

Date

Nov 30. 2022

Date

EMPIRE ELECTRIC ASSOCIATION, INC.

/s/ Josh Dellinger

Signature

Josh Dellinger, ~~General Manager~~

Printed Name of Signor

June 8, 2022

12-05-2022

Date

Exhibit A One-Line Diagram

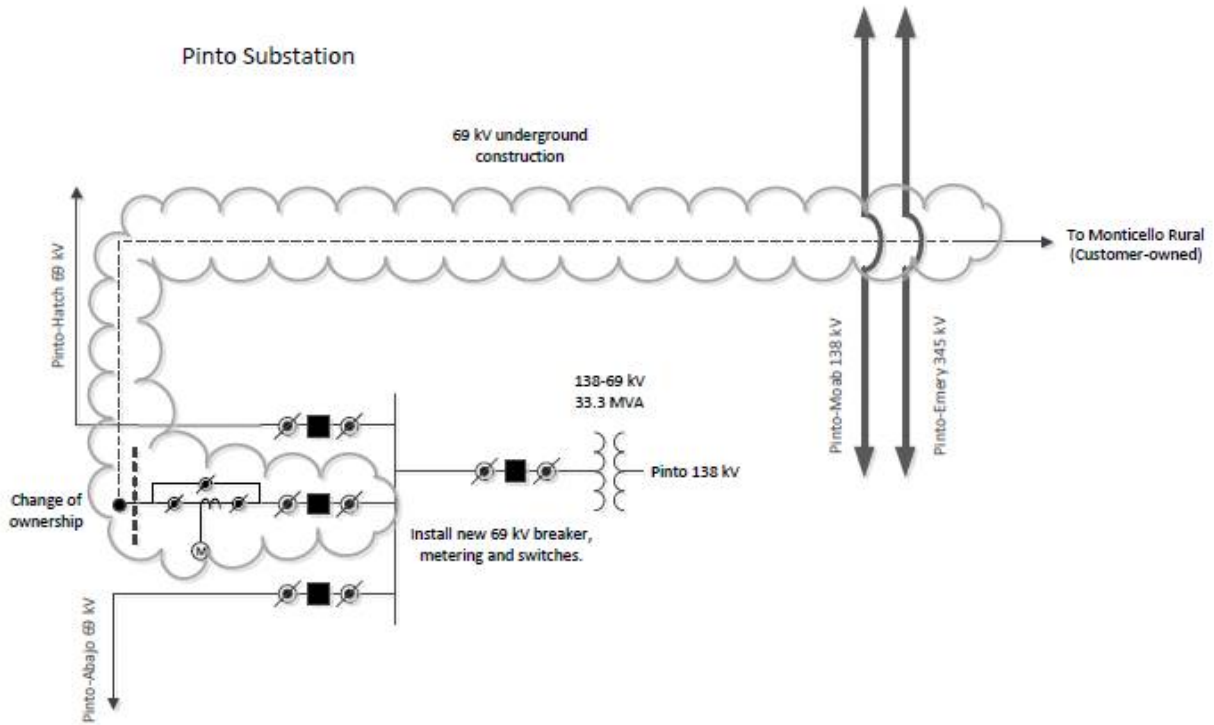

Exhibit B

Estimated Scope of Work

Equipment to be installed/constructed, responsibilities, and requirements under this exhibit may be adjusted upon mutual agreement by all Parties pursuant to project design outcomes.

At Tri-State's expense, PacifiCorp shall:

- Design, procure, construct, own and maintain the additional breaker bay in Pinto substation. This will include the installation of the following major equipment:
 1. (1) – 69 kV, circuit breaker
 2. (2) – 69 kV, switch, group operated
 3. (6) – 69 kV, switch, hook stick operated
 4. (3) – 69 kV, combined CT/VT metering unit of a high accuracy, extended range model type (0.15s B1.8, 1-200% I (rated) or higher).
 5. (3) – 69 kV, arrester
- Design, provide, and install a 69 kV breaker in the vacant bay on the Pinto 69 kV bus assembly.
- Design, provide, and install 69 kV metering on the line side of the breaker in compliance with PacifiCorp's Meter Engineering Policy 500 for Third-Party Access to Revenue Class Meter Data
- Expand the Pinto Substation to accommodate the installation of a substation outboard dead-end structure.
- Perform a CDEGS grounding analysis and modify ground grid as required.
- Modify the bus differential relay system for the connection to the EEA's load.
- Design, provide, install, and or modify the relays for the EEA's tie line.
- Procure and install communications equipment.
- Include the following data points into the Pinto substation RTU:
 1. Analogs:
 - a. MW
 - b. MV
 - c. Line Voltage A
 - d. Line Voltage B
 - e. Line Voltage C
 - f. Line Fault Location
 2. Status:
 - a. Breaker Status
- Design, procure and install 69 kV revenue metering equipment for the Project including two (2) revenue quality meters (primary and backup), test switch, instrument transformers, metering panels, junction box and secondary metering wire.
- Design, procure and install clone meter and cellular modem for Tri-State's meter data access, per PacifiCorp's Policy 500.

- Develop an Ethernet connection for retail sales and generation accounting via the MV-90 translation system.
- Review, and mitigate the design of those portions of the EEA sub-transmission line which reside on PacifiCorp property and on PacifiCorp right of way.
- Construction of the last span from the EEA underground riser structure to the Pinto Substation tower using PacifiCorp standard hardware supplied and standard conductor shield wire.
- Provide PacifiCorp standards as requested by Tri-State and/or EEA subject to PacifiCorp authorization.

At EEA's expense, EEA shall:

- Design, construct and own the 69 kV sub-transmission line from the point of interconnection and change of ownership at the Pinto Substation to EEA's Monticello substation.
- Provide and install conductor, shield wire and line hardware in sufficient quantities to allow the PacifiCorp to construct the last span of the EEA tie line from the EEA riser structure to the Pinto Substation dead end structure tower steel.
- Model, design, provide and install the sub-transmission line to avoid conflicts with the PacifiCorp facilities.
- Procure all necessary permits, property rights and/or the rights of way for the new Monticello-Pinto sub-transmission line.

Exhibit C
Estimated Schedule and Milestones

The estimated schedule and milestones are driven by the below timeframes which may be adjusted through the course of the Project. If there is a delay in any of the below activities, there will be, at a minimum, a day for day slip in the entire schedule. Any delays in the Project have the potential to affect the entire schedule.

| Milestones | Estimated Date |
|--|--|
| Tri-State Provision of Financial Security December 1, 2020 | |
| Transmission Provider Permitting and & Property Design Support Commence 2021 | January 15, |
| EEA Acquired Property/Permits/ROW Complete March 31, 2021 | |
| Transmission Provider Acquired Property/Permits/ROW Complete 2021 | March 31, |
| Transmission Provider Engineering & Procurement Commences January 15, 2021 | |
| Interconnection Customers Design Information Provided January 15, 2021 | |
| Energy Imbalance Market Modeling Data Submittal June 16, 2021 | |
| Transmission Provider Engineering Design Complete October 15, 2021 | |
| Construction Begins | January 1 <u>November 14, 2021</u> <u>2022</u> |
| Construction Complete | December 1 <u>March 29, 2022</u> <u>2023</u> |
| EEA's Facilities Receive Load | December 15 <u>April 14, 2022</u> <u>2023</u> |