

ROBERT C. KELLER (4861)
DANI CEPERNICH (14051)
SNOW CHRISTENSEN & MARTINEAU
10 Exchange Place, 11th Floor
Salt Lake City, Utah 84145
Telephone: (801) 521-9000
rck@scmlaw.com
dnc@scmlaw.com

Attorneys for Petitioner

BEFORE THE PUBLIC SERVICE COMMISSION

**IN THE MATTER OF LOGAN CITY'S
PETITION REQUESTING
INVESTIGATION INTO UNION
PACIFIC RAILROAD COMPANY'S
ADMINISTRATION OF AGREEMENTS
AND MAINTENANCE PROVISIONS**

**SUR-REBUTTAL TESTIMONY OF
THOMAS DICKINSON FOR LOGAN
CITY & LOGAN EXHIBITS 14-16**

Docket No. 21-888-01

1 **Q. Mr. Dickinson, are you familiar with Travis Bailey's testimony indicating that**
2 **Union Pacific may not have given AECOM final approval of the design for the 1400**
3 **North project?**

4 A. Yes.

5 **Q. On what was your prior testimony that Union Pacific had given AECOM final**
6 **approval of the design based?**

7 A. It was based on my experience working with AECOM on this project, including
8 discussions with Mr. Bailey, who at the time was working with AECOM. These
9 discussions included a November 9, 2018, email from Mr. Bailey that explained his
10 understanding of the status of the project was that a final interconnection report had been

11 sent to Lance, a Union Pacific project engineer, the day before Lance was let go and “[w]ith
12 Lance’s approval this project was ready to go for estimates.” A copy of that email is
13 attached to my testimony as Logan Exhibit 14. As Mr. Bailey testified, that report was later
14 issued by RailPros on January 24, 2019. My understanding is also consistent with
15 AECOM’s project tracking document for this project that shows “Railroad Approval” on
16 February 2, 2019. A copy of that document is attached to my testimony as Logan Exhibit
17 15.

18 **Q. Is there anything else that lead you to believe that Union Pacific had in fact given**
19 **approval of the design for the project?**

20 A. I would note that my understanding is consistent with Union Pacific’s Public Projects
21 Manual. Section 2.1 of that manual outlines the typical steps during the design stage. It
22 provides that after the “Applicant . . . submit[s] the final design for UP design approval”
23 and “UP . . . perform[s] final review for compliance with the Railroad and Regulatory
24 Agency requirements,” “UP will estimate the cost of the work to be done by UP.” It then
25 provides, “Once UP and the Applicant have reached concurrence on comments [to the
26 plans], the design submittal will be approved, and may move onto the agreement phase
27 followed by the construction phase, discussed in Section 14.0.” The associated Figure 2.1
28 is a flowchart of the design review process. It indicates that once Union Pacific determines
29 the plans meet design standards, the “Design [is] approved for next Plan Submittal.” Union
30 Pacific then “Approves 90% + Plans,” after which “Applicant Submits Plat Map & Legals,”
31 and then “UP Real Estate Begins Drafting Agreement & Easement.” Based on this manual,
32 my understanding is that the project would not progress to the phase of obtaining a crossing

33 estimate like we got in September 2019 or a proposed at-grade crossing agreement like we
34 got in March 2020 if the design was not approved.

35 **Q. Attached to your written testimony is Logan Exhibit 16. Is that the manual you just**
36 **referenced?**

37 A. Yes.

38 **Q. Are you familiar with Mr. Bailey's testimony that it is his opinion that Logan City**
39 **created the safety concerns you have previously addressed and those concerns could**
40 **have been mitigated without the railroad improvements?**

41 A. Yes.

42 **Q. Do you agree with that testimony?**

43 A. No.

44 **Q. Can you please explain why?**

45 A. The concerns raised in paragraphs 1 and 4 of the July 28, 2020, letter to the AG's office,
46 which is Logan Exhibit 6, addressed safety concerns that existed before construction at the
47 1400 N crossing and were part of the motivation for doing the project in the first place.
48 The concern raised in paragraph 2 would have been similar had Logan City not turned on
49 the signal, because the yield sign would still result in the cars backing up and stacking on
50 the railroad tracks as discussed in paragraph 1. Although the construction that occurred
51 outside of the right-of-way led to the concern discussed in paragraph 3, Logan City had no
52 reason to believe that there would be such a delay in entering into a crossing agreement,
53 and specifically that Union Pacific would refuse to abide by the original R 930-5-8 and
54 would continue to do so even after that rule was clarified.

55 **Q. Does this conclude your testimony?**

56 **A. Yes.**

I declare under criminal penalty under the law of Utah that the foregoing is true and correct.

DATED this 25th day of April, 2022, in Cache County, Utah.



Thomas Dickinson



tom.dickinson <tom.dickinson@loganutah.org>

DOT# 806354Y, 1400 North, Logan

Bailey, Travis (Salt Lake City) <Travis.Bailey@aecom.com>

Fri, Nov 9, 2018 at 1:42 PM

To: "Chris T. Keckeisen" <CTKECKEI@up.com>

Cc: "Karen Hankinson (karen.hankinson@railpros.com)" <karen.hankinson@railpros.com>, "tom.dickinson@loganutah.org" <tom.dickinson@loganutah.org>

Chris,

One of the projects I mentioned on the phone today was DOT# 806354Y. My understanding was that the finalized report was sent to Lance the day before he was let go. With Lance's approval this project was ready to go for estimates. Please send this on for estimates. I will send a separate email about the other project.

Thanks,

Travis C Bailey, PE

Transportation Engineer

D 1.801.904.4178

C 1.801.550.8037

travis.bailey@aecom.com

AECOM

756 East Winchester Street, Suite 400, Salt Lake City, UT 84107

T 1.801.904.4000 F 1.801.904.4100

www.aecom.com

Railroad Progress Tracking

Current Date:

10/8/2020

Days from Diagnostic 7
 Days sent to Eric 7
 Days from signature 0
 Days from Diagnostic 14
 Days from Agency Signature 2
 Days from Submittal 14
 Days from UPRR Signature 0
 Days from UPRR Signature 14
 Days from Submittal 150
 Days from Comments 30
 Days from Submittal 150
 Days from Comments 30
 Days from Submittal 30
 Days from Approval 150
 Days from Estimate 14
 Days from Agency Signature 7
 Days from Submittal 60
 Days from UPRR Signature 14
 Days from Comptroller Signature 3

PIN	Project Name	Railroad	DOT#	Concept Development										Project Execution							Final Agreement							
				Surveillance Report				Preliminary Engineering Agreement						Scheduled Submittal	Plans			Preemption Calculations				Railroad Approval	Estimate Received	Final Agreement				
				Diagnostic Review	Sent to Eric	Signed by Eric	Report Distribution	Signed by Agency	Sent to Railroad	Signed by Railroad	Railroad NTP	Signed by Comptroller	Submit to Railroad		Railroad Comments Received	Final Submittal to Railroad	Submit to Railroad	Railroad Comments Received	Final Submittal to Railroad	Signed by Agency	Sent to Railroad			Signed by Railroad	Signed by Comptroller	Railroad NTP		
	Safety Projects				4	7	3	14*	3	14	3	14			150	30	3	150	30	30	150	14	7	60	14	3		
	1400 North 600 West	UPRR	806354Y						12/8/16	12/14/16	12/14/16	NA	4/10/18	4/10/18	9/7/18	12/11/18	4/10/19	9/7/18	12/11/18	2/2/19	9/22/19							

* Days from diagnostic review
 On Schedule
 Behind Schedule
 Greater than 2X behind schedule

Union Pacific Railroad Public Projects Manual



Version 001, July 30, 2021



Disclaimer: This Union Pacific Railroad Public Projects Manual should not be considered an all-inclusive reference document; rather, it is intended to be a guidance document used as a general resource. Nothing identified in this Union Pacific Railroad Public Projects Manual can be taken as authority to construct on or near the Union Pacific Railroad property. This manual is provided for reference only and is subject to revision without notice. Union Pacific Railroad approval of Construction Documents, execution of a Construction and Maintenance Agreement, and execution of a Right of Entry Agreement (if applicable) are required prior to beginning construction. Individual projects will be subject to analysis of all factors leading to formal agreements among all project parties.

Copyright © 2021, All rights reserved. Union Pacific Railroad, 1400 Douglas Street, Omaha, NE 68179



Contents at a Glance

Introduction to this Manual

Introduction to this Manual (Sec. 1) and a summary of the Public Projects process (Sec. 2)

Active Grade Crossing Warning Systems

Active Grade Crossing Warning Systems, including Preemption requirements (Sec. 3)

Highway-Rail Grade Crossings

Surface replacement (Sec. 4.1); widening and reconstruction (Sec. 4.2); new and closures (Sec. 4.3 & 4.4), and private crossing to public (Sec. 4.5)

Maintenance Consent Process

Maintenance activities for existing at-grade and grade separations (Sec. 12.1.3)

Grade Separations

Grade separation projects, either overpass or underpass (Sec. 5)

Sidewalks and Pathways

Coordination related to any bicycle, pedestrian, or multi-use pathway crossings perpendicular or adjacent to the railroad (Sec. 6)

Parallel Roadway & Adjacent Construction

Projects that are parallel to the railroad (Sec. 7)

Construction Monitoring

Construction monitoring requirements (Sec. 14)

UP's Cost Reimbursements and Insurance

Reimbursement of cost and expenses (Sec. 11), and insurance requirements for public projects (Sec. 11.5)

Agreements and Right of Entry onto or across Railroad Property

Entry onto UP Right of Way property (Sec. 12)

Railroad Flagging

Railroad flagging for activities on or near UP Right of Way property (Sec. 13)

Engineering Review Requirements and Schedules

Requirements for engineering review, and review schedule (Sec. 10)

Utilities

Signal and communications cable locates and protection, and utility crossings (Sec. 15)

Painting and Maintenance

Bridge painting, graffiti abatement, Railroad Property beautification (Sec. 9.1 and 9.2), and maintenance within Railroad Property (Sec. 9.3)

Quiet Zones

UP's involvement and FRA's quiet zone rule (Sec. 8)

Additional Resources and Glossary

Additional external sources that might be helpful and a glossary of terms found in this Manual (Sec. 17)



Detailed Contents

Section 1 Introduction to this Manual	1-1	2.2.4 Diagnostic Team meeting Minutes	2-12
1.1 Public Project Examples	1-1	2.2.5 Diagnostic Review Form	2-12
1.2 Important Information	1-2	2.2.6 State Department of Transportation and/or Public Utilities Commission Requirements	2-12
1.3 Project Location	1-2	2.3 UP Fourth Quarter Construction Moratorium	2-12
1.4 Public Projects Staff, General Roles, Contacts, and Territory	1-4	2.4 Approval Expiration	2-12
1.5 Additional UP Resources and Contacts	1-4	Section 3 Active Grade Crossing Warning Systems including Preemption Requirements	3-13
1.5.1 Union Pacific Contact List	1-5	3.1 Overview	3-13
1.5.2 Public Notices	1-5	3.2 Design Considerations	3-14
1.5.3 Reporting Emergencies, Unusual or Suspicious Occurrences, and Environmental Hazards	1-5	3.3 Operation of the Active Grade Crossing Warning System	3-15
1.5.4 Reporting Rough or Damaged Grade Crossings or other non-emergencies	1-5	3.4 Engineering, Cost Estimation, Installation, and Maintenance	3-15
1.5.5 UP Public Affairs	1-5	3.5 Traffic Signal Interconnect / Railroad Preemption	3-16
1.5.6 Other Public Information	1-5	3.5.1 Traffic Signalized Intersection	3-16
1.5.7 Key Partnership Requests	1-5	3.5.2 Stop Controlled Intersection	3-16
1.5.8 Community Events Requests:	1-6	3.5.3 Exit Gates and Exit Gate Management Systems	3-17
1.5.9 Requesting Train Counts	1-6	3.5.4 Advance Warning Device Flashing Signal Interconnect	3-17
1.5.10 Photo and Video Guidelines	1-6	3.5.5 Annual Preemption Inspection	3-17
1.5.11 Unmanned Aerial Systems - Drone Policy	1-6	Section 4 Grade Crossings	4-18
1.5.12 Oversize/Overweight Transport Vehicle Requests	1-7	4.1 Surface (Planking) Replacement Only	4-18
Section 2 Process Summary for Public Projects	2-8	4.2 Roadway Reconstruction and /or Widening	4-20
2.1 Typical Steps for Design Review	2-8	4.3 New Crossing	4-21
2.2 Field Diagnostic	2-10	4.3.1 Grade Crossing Safety	4-21
2.2.1 Attendees	2-10	4.3.2 New Highway-Rail Grade Crossing Application Procedure	4-21
2.2.2 Diagnostic Review Preparation	2-11		
2.2.3 Diagnostic Review Process	2-11		



4.3.4 Temporary Grade Crossing / Haul-Road Crossing.....	4-22	5.9 Summary.....	5-31
4.4 Crossing Closures and Consolidation.....	4-22	Section 6 Sidewalks and Pathways.....	6-32
4.5 Conversion of Private Crossing to Public.....	4-24	6.1 Sidewalks.....	6-32
4.6 Temporary Traffic Control in proximity to Highway-Rail Grade Crossing.....	4-24	6.2 Bicycle/Pedestrian Pathways.....	6-32
4.7 Grade Crossing Maintenance Responsibilities.....	4-24	6.3 Multi-Use or Recreational Pathways.....	6-33
Section 5 Grade Separation Projects.....	5-25	Section 7 Parallel Corridor and Other Projects.....	7-34
5.1 Overview.....	5-25	7.1 Overview.....	7-34
5.2 Key Understandings.....	5-26	7.2 General Guidelines.....	7-34
5.3 Temporary and Permanent Construction Clearances...5-27		7.3 Key Considerations.....	7-35
5.3.1 Permanent Clearances.....	5-27	7.4 Commercial Developments or Parallel Project Environmental Reviews.....	7-36
5.3.2 Permanent Vertical Clearance (Under an Overpass Grade Separation).....	5-28	7.5 Levee / Flood Walls.....	7-36
5.3.3 Permanent Horizontal Clearance (Under an Overpass Structure).....	5-28	7.6 Alternative Delivery.....	7-38
5.3.4 Permanent Vertical Clearance (Under an Underpass Structure).....	5-28	7.7 Commuter / Passenger Transit Projects.....	7-38
5.3.5 Permanent Horizontal and Vertical Clearances (on an Underpass Structure).....	5-29	7.7.1 Commuter Design.....	7-38
5.3.6 Sacrificial Impact Protection Devices.....	5-29	Section 8 Quiet Zones (QZ).....	8-39
5.3.7 Temporary Vertical Clearance.....	5-29	8.1 Quiet Zone Rule.....	8-39
5.3.8 Temporary Horizontal Clearance.....	5-29	8.2 Minimum Requirements for a QZ.....	8-39
5.4 Temporary Shoring.....	5-29	8.2.1 Minimum Length.....	8-39
5.5 Shoofly or Detour Track Design.....	5-29	8.2.2 Active Warning Devices.....	8-39
5.6 Pathway Grade Separations.....	5-30	8.2.3 Advance Warning Signs.....	8-39
5.7 Roadway Signs and Utilities Installed on UP Bridges...5-30		8.2.4 Bells.....	8-40
5.8 Maintenance Responsibilities.....	5-30	8.2.5 Private or Pedestrian Crossings.....	8-40
5.8.1 Overpass Grade Separation Maintenance.....	5-31	8.2.6 MUTCD Compliance.....	8-40
5.8.2 Underpass Grade Separation Maintenance.....	5-31	8.3 How to Initiate a QZ at UP Crossings.....	8-40
		8.3.1 Pre-diagnostic Call.....	8-40
		8.3.2 Field Diagnostic.....	8-40
		8.4 QZ Designation.....	8-41



8.4.1 Public Authority Designation.....	8-41	10.12 Checklist for Projects with Culverts, Drainage Pipes, or Conduits.....	10-51
8.4.2 Public Authority Application.....	8-41	10.13 Review Submittals and Schedules.....	10-52
8.5 Notices Required to Establish a QZ.....	8-42	10.14 Requests for Exception Variance.....	10-54
8.5.1 Notice of Intent (NOI).....	8-42	Section 11 Payment of UP's Cost, Expenses, and Insurance.....	11-55
8.5.2 Notice of Establishment (NOE).....	8-42	11.1 UP's Design Review Cost Reimbursement.....	11-55
8.6 General Costs of Safety Measures.....	8-43	11.2 UP's Railroad Improvement Costs.....	11-55
8.7 Contact Information.....	8-43	11.3 UP's Flagging Costs.....	11-55
8.8 Union Pacific Project Agreements.....	8-43	11.4 UP's Real Estate Fees.....	11-55
Section 9 Bridge Painting, Railroad Property Beautification, and Maintenance.....	9-44	11.5 Insurance Requirement for Public Projects.....	11-55
9.1 Bridge Painting – Anti-Graffiti.....	9-44	11.5.1 Railroad Protective Liability Insurance.....	11-57
9.2 Railroad Property Beautification.....	9-44	Section 12 Agreements and Rights of Entry.....	12-58
9.3 Maintenance.....	9-44	12.1 Agreements.....	12-58
Section 10 Engineering Submittal Requirements and Review Schedule.....	10-45	12.1.1 Reimbursement Agreement.....	12-58
10.1 Plan Set Description.....	10-45	12.1.2 Construction and Maintenance Agreement.....	12-59
10.2 Checklist for All Plan Sets.....	10-45	12.1.3 Maintenance Consent Letter Agreement.....	12-59
10.3 Checklist for Construction Project or Development Adjacent to UP ROW.....	10-46	12.1.4 Master Agreement.....	12-59
10.4 Checklist for Projects with Traffic Control Plans.....	10-46	12.2 Entry onto UP Right of Way or Property.....	12-59
10.5 Checklist for Projects with Overpasses.....	10-47	12.2.1 ROE – Non-Intrusive.....	12-60
10.6 Checklist for Projects with Underpasses.....	10-47	12.2.2 ROE – Temporary Use (Intrusive).....	12-60
10.7 Checklist for Projects with At-Grade Crossings.....	10-47	12.2.3 Railroad ROW Mapping Requests from UP.....	12-61
10.8 Checklist for Projects with Active Grade Crossing Warning Systems.....	10-49	12.3 Real Estate Purchases.....	12-62
10.9 Checklist for Interconnected Crossing Projects with Traffic Signal Preemption.....	10-50	Section 13 Railroad Flagging/Protection for Activities On/Near Railroad Property.....	13-63
10.10 Checklist for Projects with Railroad Crossing Surface / Planking Only.....	10-50	13.1 What is Railroad Flagging/Protection.....	13-63
10.11 Checklist for Projects with Crossing Closures.....	10-51	13.2 Flagging Process.....	13-63
		Section 14 Construction Monitoring Requirements.....	14-64
		14.1 Overview.....	14-64
		14.2 General Guidelines.....	14-64



14.3 Typical Steps for Construction.....	14-64	Appendix A Quick Reference Sheet.....	A-1
14.4 Demolition.....	14-65	Appendix B Contact Center Inquiry Submission Form.....	B-1
14.4.1 Key Considerations.....	14-65	Appendix C Design Review Comment Tracking Spreadsheet.....	C-1
14.4.2 Demolition Plan.....	14-66	Appendix D Crossing Diagnostic Items and Form.....	D-1
14.5 Construction Crane Encroachments.....	14-66	Appendix E Guidance for Sidewalk Improvements.....	E-1
14.5.1 Key Considerations.....	14-66	Appendix F Sample Grade Crossing Plan Sheet RURAL.....	F-1
14.6 Falsework Requirements/Shoring.....	14-67	Appendix G Sample Grade Crossing Plan Sheet URBAN.....	G-1
14.7 Shop Drawings and Material Verifications.....	14-67	Appendix H Structure Site Selection Report Guidelines.....	H-1
Section 15 Utility Locates, Crossings, and Protection.....	15-68	Appendix I Bridge Ownership and Maintenance.....	I-1
15.1 Overview.....	15-68	Appendix J Sample Parallel Encroachment Sheet.....	J-1
15.2 UP Signal and Communication Cable Locates and Protection.....	15-68	Appendix K Drainage Criteria.....	K-1
15.2.2 Utility Guidelines.....	15-68	Appendix L Commuter Access Principles.....	L-1
15.2.3 General Process.....	15-69	Appendix M Special Conditions for Construction Near UP Property.....	M-1
15.3 Utility Locates within UP Right of Way.....	15-69		
15.4 Utility Crossings.....	15-69		
15.4.1 Pipeline Crossings.....	15-70		
15.4.2 Wireline Crossings.....	15-70		
Section 16 Public Safety Initiatives.....	16-71		
16.1 Crossing Assessment Process.....	16-71		
16.2 UP Cares.....	16-72		
16.3 Education.....	16-72		
Section 17 Additional Resources.....	17-73		
17.1 UP Design Standards and Guidance.....	17-73		
17.2 External Sources.....	17-73		
17.3 Glossary.....	17-74		
17.4 Abbreviations.....	17-80		



Figures

Figure 1.1 Contact Center Project Location.....	1-3
Figure 2:1 Design Review Process.....	2-9
Figure 3.1 MUTCD Figure 8C-1.....	3-14
Figure 4.1 Plan View of Surface & Approach Pavement.....	4-19
Figure 4.2 Typical Section of Ballast and Asphalt Detail.....	4-20
Figure 4.3 Plan View of Panel & Joint Weld Location.....	4-20
Figure 4.4 Road Closure – Rural (Minimum).....	4-23
Figure 4.5 Road Closure – Urban with Cul-de-sac.....	4-23
Figure 4.6 Roadway Crossing Maintenance Limits.....	4-24
Figure 5.1 Grade Separation Elevation.....	5-25
Figure 5.2 Agency Grade Separation Ownership & Maintenance Responsibilities.....	5-31
Figure 7.1 Plan View of Parallel Encroachment Removed.....	7-35
Figure 7.2 Section View of Drainage on Parallel Highway.....	7-35
Figure 7.3 3D Model of Flood Wall Gate Closure.....	7-37
Figure 7.4 Section of Flood Wall Gate Closure.....	7-37
Figure 10.1 Table 2C-4 Deceleration to 0mph.....	10-48
Figure 12-1 Reimbursement Agreement Process.....	12-58
Figure 15.1 Encased Non-Flammable Pipeline.....	15-70
Figure 15.2 Gas (Non-Liquid Natural State) Flammable Pipeline.....	15-70
Figure 15.3 Overhead Wireline Crossing.....	15-70

Tables

Table 8.1 QZ Safety Measure Estimated Costs.....	8-43
Table 10.1 Public Project Highway-Rail Grade Crossing Submittals and UP Review Times.....	10-53
Table 11.1 Management and Design Review Costs	11-56





Section 1 Introduction to this Manual

The information contained in this Union Pacific Railroad Public Projects Manual (Manual) is intended to be a guide for assisting communities, highway agencies, other authorities, industries, or private entities, hereinafter referred to as Applicants in administering, coordinating, planning, and implementing construction projects that involve Railroad Property. Applicants are considered a citizen, consultant, contractor, developer, government, industry, railroad, road authority, or UP Customer.

A Union Pacific Railroad (UP, UPRR, or Railroad) Public Project can be defined as any Roadway, bridge, commercial development, parallel corridor, or utility project that is owned or used by the public or by a private entity and that encroaches within Railroad Property. See the [Glossary](#) and the [Abbreviations](#) at the end of this Manual for additional definitions; note defined terms are capitalized throughout this Manual.

This Union Pacific Railroad Public Projects Manual should be used as a reference to instruct and guide Applicants in progressing their Public Projects. It is recommended that prior to initiating contact with the UP Public Projects team, this Manual be reviewed in detail provided it will assist Applicants in coordination with UP.

1.1 Public Project Examples

Some examples of Public Projects include the following:

- **Highway-Rail Grade Crossings:** installation of Flashing-Light Signals and gates, replacement of existing At-Grade Crossing surface, At-Grade Crossing surface, modifications to existing At-Grade Crossing, Signs for At-Grade Crossing, Crossing Surface Replacement, and At-Grade Crossing closures.

- **Entry onto Railroad Property:** temporary rights of entry, temporary Easements, permanent Easements, utility installations, and maintenance activities.
- **Grade Separation Projects:**
 - Overpass (vehicle, pedestrian, commercial-supporting bridges): construction, reconstruction, rehabilitation, repair, removal, and maintenance of bridges over Railroad Property initiated by outside parties.
 - Underpass (train-supporting bridges): construction, reconstruction, rehabilitation, repair, removal, and maintenance of bridges on or near the Railroad Property carrying the Railroad over Roadways and other public properties initiated by outside parties.
- **Private Crossings:** construction, reconstruction, rehabilitation, repair, removal, and maintenance of a Private Crossing by an adjacent property owner who has legal rights to cross the Railroad at-grade for personal or business use; public access is prohibited.
- **Pathway Crossings:** construction, reconstruction, rehabilitation, repair, removal, and maintenance of shared-use paths, multi-use trails, and on or near Railroad Property, that is not included with an adjacent Highway-Rail Grade Crossing.
- **Parallel roads:** construction, reconstruction, modification, removal, and maintenance of parallel roads or other public and commercial development facilities, including Pathways, on or near Railroad Property.
- **Bridge painting and Railroad Property beautification:** painting of structures, regardless of ownership, on or near Railroad Property. Includes the modification of structures on or near Railroad Property involving aesthetic work and the beautification of Railroad Property.
- **Maintenance on Railroad Property:** maintenance or grading activities above, below, or near Railroad Property related to a structure, At-Grade Crossing, or parallel facility.



- **Quiet Zones:** information for an Applicant proposal to establish a new Quiet Zone.
- **Active Grade Crossing Warning Systems including traffic signal Preemption requirements:** adding signal preemption to an existing crossing, adjusting warning times, roadway geometric changes that warrant warning device adjustments.
 - Roadway lane widening: widening the Roadway approaching a Highway-Rail Grade Crossing or Railroad Property.
 - Addition of new Sidewalks: adding Sidewalks on a Roadway corridor that is approaching or wishes to cross a Highway-Rail Grade Crossing.
 - Closure of Highway-Rail Grade Crossing: permanent closure of an existing At-Grade crossing.
 - Other projects involving Railroad Property: publicly sponsored projects involving or altering Railroad Property or UP facilities. These projects may be on, above, adjacent to, near, or otherwise have the potential to impact, Railroad Property and operations.

1.2 Important Information

The users of this Manual should also consider the following important information:

- The safety of UP employees and the public is of paramount importance to UP.
- Always expect a train, from any direction at any time, and look both ways before crossing.
- Only cross the tracks at designated railroad crossings, located where the street intersects with the tracks.
- Never walk between the rails or areas that are not designated railroad crossings.
- Avoid distractions, including loud music, texting, or talking on cell phones, when crossing railroad tracks.
- Stay away from trains and other Railroad Property, including bridge trestles, culverts, Yards, and equipment.

- The specific UP requirements for Public Projects, as described in this Manual, shall be followed at all locations where UP owns and/or operates, regardless of track ownership or whether the track is active or dormant.
- This Manual is provided for reference only and is subject to change without notice.
- All new Public Projects shall be designed in accordance with the most current UP policies, requirements, and standards.
- Any items or project types on or near Railroad Property that are not covered in this Manual are subject to UP's review and approval.

1.3 Project Location

An Applicant should unequivocally determine its project is on or near UP's Property prior to contacting the UP. The information included below should be used by the Applicant to positively find the location of the proposed project. An accurate location reference will help facilitate the overall process:

- The UP Contact Center can be utilized to obtain GPS locate information for a project using the Google Map feature as shown in **Figure 1.1 Contact Center Project Location** on the next page.



Figure 1.1 Contact Center Project Location

Project Location

DOT # (ex. #####X or 430346N) GPS Lat (ex. 35.984135) GPS Long (ex. -101.952345)

Street City State

Location Description *

Complete this field for project locations that do not have a DOT or GPS Lat/Long



Be advised that UP trains, locomotives, railcars, and equipment operate on rail lines owned by UP and over rail lines owned by other railroads; therefore, observations of these types of operations should not be relied on to determine if a specific rail line is owned by UP.

- The FRA database can also be used to obtain crossing location information. Use the following steps to locate specific Highway-Rail Grade Crossings:

- Locate the blue Emergency Notification Sign (ENS) found at every crossing. Each Highway-Rail Grade Crossing has a unique US Department of Transportation (USDOT) inventory number that includes six numbers and one letter which can be found on the ENS.
- Enter this unique USDOT inventory number in the Federal Railroad Administration (FRA) Office of Safety Analysis' Crossing Inventory Database at <https://safetydata.fra.dot.gov/OfficeofSafety/PublicSite/Crossing/Crossing.aspx>



and click on the "Generate Report" button to find additional information about the crossing.

- On the same FRA website, click on the "Generate Map" button to help locate the crossing. Zoom into the crossing in question to locate the USDOT inventory number.
- On the same FRA website, under the heading "Additional Links," click on "Query by Location/Railroad" and enter the state, county/city, and street name to locate the specific crossing.
- To determine whether a specific parcel of land is Railroad Property, contact the local county assessor or consult local courthouse records. Be advised these resources are often a generalization of the property limits, and as such, a legal survey will be required for all property transactions.



UP requires the following information be provided at the top of the page for all correspondence:

- Type of project (Grade Separation, Signal, Surface, Quiet Zone, Closure)
- City and State Location
- FRA USDOT Inventory Number
- Railroad Mile Post and Subdivision Name
- Roadway Authority (Applicant)

1.4 Public Projects Staff, General Roles, Contacts, and Territory

UP operates in 23 states in the western two-thirds of the United States. Headquartered in Omaha, Nebraska, the Railroad operates approximately 32,200 route miles serving nearly 7,300 communities. UP's Public Projects team is involved in a wide variety of Public Projects initiated by various Public Road Authorities and other Applicants across its system.

The primary role of UP's Public Projects team is to be the main point of contact for local communities, public agencies, and other Applicants when they have projects on or near Railroad Property. Public Project examples are included in [Section 1.1](#).

The Manager of Public Projects (MPP) role includes processing projects after the request is made to modify Railroad Property. Any permits, agreements, and other documentation required by UP for the processing of Public Projects work are identified by project type throughout this Manual.

UP utilizes Public Project Engineering Consultants (PP-EC) authorized to represent UP to manage the Public Projects submitted to UP, with the processing, engineering reviews, and license or agreement costs passed through to the Applicant.

The assigned Public Project Engineering Consultant (PP-EC) will have full authority to communicate UP requirements during the Public Project process.

UP's PP-EC is the primary point of contact; however, for most Public Projects, there are several circumstances where UP's Real Estate team will need to also be involved. The PP-EC will coordinate with the UP Real Estate team processing property transactions related to public projects, such as:

- Permits
- Licenses
- Leases
- Easements, both Permanent and Temporary
- Right of Entry for Temporary Use of Railroad Property
- Installation of new utilities both above and below ground
- Transport vehicles or dimensional moves across the tracks (e.g., houses or windmill blades)
- Minor construction work such as soil borings or grading, surveying, and geotechnical engineering.

1.5 Additional UP Resources and Contacts

There are many resources available on the UP Website. Most of the pertinent links have been included in the [Appendix A – Quick Reference Sheet](#).

Many areas of community interest are outside the purview of the UP Public Projects team and the scope of this Manual. This section identifies additional UP resources and contacts that may be helpful on other community matters and public inquiries.

1.5.1 Union Pacific Contact List

The UP [website](#) includes a contact list, but not all company phone numbers and email addresses are listed. Specific department contact list links are included. Mail can be sent to any employee c/o the postal address.

Company Mailing Address and Phone:

Union Pacific Railroad
1400 Douglas Street
Omaha, NE 68179
402-544-5000 or 888-870-8777

1.5.2 Public Notices

The following are the most common types of notices submitted to UP:

- A. A zoning notice will be provided from a City, Town or County in connection with an intended change to land use requirements or in response to a request to make changes to land use.
- B. An annexation notice may be sent to a property owner whose property is the subject of, or may be affected by, a petition to annex land into a municipality.
- C. A special assessment notice may be from a governmental or quasi-governmental entity, which seeks to impose a financial assessment on a particular property or group of properties for a particular purpose such as construction of a road or irrigating infrastructure.
- D. Environmental Reports (e.g., Environmental Impact Statement, Environmental Assessment) may be sent from a government entity seeking input on impacts ass the entity plans a public project.

All public notices shall be submitted to the appropriate UP Real Estate Property Manager through the [website](#). Choose "Property Management" option and then choose the "State" the project is located. This will provide the appropriate UP contact information. Neither the MPP nor the PP-EC process the responses to the Public Notices.

1.5.3 Reporting Emergencies, Unusual or Suspicious Occurrences, and Environmental Hazards

Please call UP Response Management Communication Center (RMCC) 1-888-UPRR COP (877-7267) to report hazardous materials releases, personal injuries, criminal activities, illegal dumping, other environmental incidents or other emergencies.

1.5.4 Reporting Rough or Damaged Grade Crossings or other non-emergencies

Please call 1-800-848-8715 to report Grade Crossing blockages or damage.

1.5.5 UP Public Affairs

The UP Public Affairs team includes **Public Affairs Directors** who address challenges and opportunities at the local, county, and regional government levels, and serve as liaisons with the public and the media. All media inquiries must be directed to the UP Media Team. See UP's **Public Affairs Regional Map** to find the correct contact.

1.5.6 Other Public Information

Other public information related to news media contacts, environmental management contacts, the UP Foundation, the UP Museum, employment, law / risk management, and merchandise is available on our [website](#).

1.5.7 Key Partnership Requests

Key partnerships helps UP support the mission of building safe, prosperous, and vibrant communities by providing large-scale, targeted grants intended to achieve significant, measurable, and sustainable impact focused on our priority cause areas in key communities. Key partnerships incorporate two subgroups, national and regional, and will be selected by invitation only. Additional information about key partnerships is available on the [website](#).



1.5.8 Community Events Requests:

UP's highest priority is safety of our employees and the communities we serve

UP strongly encourages community leaders and event organizers to plan activities so they do not cross railroad tracks or approach railroad property.

Any community event that will utilize a public or private roadway or path desiring to cross the UP ROW must submit a request to UP for approval. Community events include, although are not limited to, the following events:

- Sporting events such as marathons and bicycle rides
- Motorcades including car or motorcycle parades
- County or state fairs, carnivals, and farmers markets
- Parades, celebrations, concerts, rallies, marches or other large gatherings

The Community Event Notification Flyer can be found at the UP webpage below:

https://www.up.com/aboutup/community/safety/community_event/index.htm

1.5.9 Requesting Train Counts

Often times Agencies request the number of trains that traverse through a particular crossing or area. These train counts may be used for a variety of public uses such as grant applications, noise studies, development studies, housing authority applications, traffic studies, and other similar types of needs.

It is not necessary to call the Railroad to determine the number of trains for a particular area. An Applicant should first find the specific location as outlined in Section 1.3 of this Manual then research the FRA inventory database to find the train count information.

The USDOT inventory form includes the number of Total Day Thru Trains, Total Night Thru Trains, Total Switching Trains, and the Total Transit Trains. Additionally it provides the speed of the train at the crossing. The link for the Federal Railroad Administration (FRA) Office of Safety Analysis' Crossing Inventory Database is as follows:
<https://safetydata.fra.dot.gov/OfficeofSafety/PublicSite/Crossing/Crossing.aspx>

Train operations and the number of trains fluctuate depending on many variables including customer activity and necessary re-routing. At a minimum, the Applicant should review USDOT Crossing Inventory Database at least annually when developing a project.

1.5.10 Photo and Video Guidelines

Safety is of paramount importance to UP. Taking photos or videos while on Railroad Property is not allowed. It is important that Agencies report any unsafe motorists or pedestrians to UPRR RMCC, see [Section 1.5.3](#). UP collects data regarding the environment and infrastructure and shares this information with State Agencies. Refer to UP [website](#) link for additional guidance.

1.5.11 Unmanned Aerial Systems - Drone Policy

Unmanned Aerial Systems (UAS), or drones, are a new way of collecting information while keeping individuals out of harms way.



Introduction to this Manual

Process Summary for Public Projects

Active Grade Crossing Warning Systems including Preemption Requirements

Grade Crossings

Grade Separation Projects

Sidewalks and Pathways

Parallel Corridor and Other Projects

Quiet Zones (QZ)

Bridge Painting, Railroad Property Beautification, and Maintenance

Engineering Submittal Requirements and Review Schedule

Payment of UP's Cost, Expenses and Insurance

Agreements and Rights of Entry

Railroad Flagging/Protection for Activities On/Near Railroad Property

Construction Monitoring Requirements

Utility Locates, Crossings, and Protection

Public Safety Initiatives

Additional Resources

All Applicants, Consultants, and Contractors must follow the policies UP has set forth for UAS and obtain permission prior to entering the Railroad ROW or its airspace. Drones may not take off from or land on Union Pacific property unless the pilot is authorized to do so in writing by a specific agreement with the Railroad. See [website](#) link for specific guidance.



Photo credit: UP website – UP Inspector preparing UAS for flight to inspect bridge.

1.5.12 Oversize/Overweight Transport Vehicle Requests

All requests for transporting large items across the Railroad's property should be directly submitted to UP's Real Estate Manager through the Response Management Control Center (RMCC).

Types of requests include the following:

- Moving houses or trailers
- Equipment transportation (windmill blades, industrial oversized loads, etc.)

These requests should be submitted at the link below: https://www.up.com/real_estate/house_moves/index.htm

Real Estate staff will review the request and send it to the MPP to determine potential impacts to the Railroad's infrastructure. Railroad Flagging Protection will likely be required during these dimensional transports.

Introduction to this Manual

Process Summary for Public Projects

Active Grade Crossing Warning Systems including Preemption Requirements

Grade Crossings

Grade Separation Projects

Sidewalks and Pathways

Parallel Corridor and Other Projects

Quiet Zones (QZ)

Bridge Painting, Railroad Property Beautification, and Maintenance

Engineering Submittal Requirements and Review Schedule

Payment of UP's Cost, Expenses and Insurance

Agreements and Rights of Entry

Railroad Flagging/Protection for Activities On/Near Railroad Property

Construction Monitoring Requirements

Utility Locates, Crossings, and Protection

Public Safety Initiatives

Additional Resources



Section 2 Process Summary for Public Projects

This Manual is intended to help communities and other project participants plan, coordinate, and construct improvement projects that may potentially involve Railroad Property. This section provides a general summary of the typical steps for the design and construction of agency and third-party projects that may potentially impact the UP ROW.

2.1 Typical Steps for Design Review

Typical steps during the design stage of the Public Project are listed below and are presented in **Figure 2.1 Design Review Process**.

- The Applicant determines the location of their project on the UP system, as discussed in **Section 1.2**.
- The Applicant notifies the UP Public Projects team of the project by providing location information, conceptual plans, and other available preliminary information through UP's **Public Project Contact Center**. See **Appendix B - Contact Center Inquiry Submission Form**.
- UP will assign a PP-EC to be the point of contact for the Applicant.
- The Applicant must enter into a standard formal Reimbursement Agreement (RA) with UP prior to any design reviews or field Diagnostic Team meetings. See **Section 12 Agreements and Rights of Entry** for more information.
- The RA gives UP the authorization to incur and be reimbursed for engineering and other costs that are actually incurred. UP may need to retain an outside consultants for the engineering and other reviews of the submitted project.
- The Applicant will be required to obtain a Non-Intrusive Permit for survey during the design phase. See **Section 12 Agreements and Right of Entry** for more information.

- The Applicant will submit project concept information, and attend field diagnostic and other meetings (as needed) with the PP-EC.
- The Applicant submits updated plans to UP based upon this Manual and the **Public Project Track Design Guidelines**.
- The PP-EC will coordinate internal UP reviews of the plans and will provide comments to the Applicant.
- Throughout the review process, the Applicant and/or its consultant will be required to complete a UP Review Comment Tracking Sheet. See **Appendix C - Design Review Comment Tracking Spreadsheet**.
- The Applicant will respond to UP comments and adjust the design, if necessary.
- The Applicant will submit the final design for UP design approval.
- UP will perform final review for compliance with Railroad and Regulatory Agency requirements.
- UP will estimate the cost of the work to be done by UP, including flagging.
- Once UP and the Applicant have reached concurrence on comments, the design submittal will be approved, and may move onto the agreement phase followed by the construction phase, discussed in **Section 14.0**.

The approval of the design plans is not the end of the Applicant's submittals. The Real Estate Contract Manager will be assigned to coordinate establishing a new crossing agreement or modifying an existing crossing agreement. The Applicant is required to obtain a Right of Entry Permit (ROE) prior to any work onsite.



BUILDING AMERICA®

- Introduction to this Manual
- Process Summary for Public Projects**
- Active Grade Crossing Warning Systems including Preemption Requirements
- Grade Crossings
- Grade Separation Projects
- Sidewalks and Pathways
- Parallel Corridor and Other Projects
- Quiet Zones (QZ)
- Bridge Painting, Railroad Property Beautification, and Maintenance
- Engineering Submittal Requirements and Review Schedule
- Payment of UP's Cost, Expenses and Insurance
- Agreements and Rights of Entry
- Railroad Flagging/Protection for Activities On/Near Railroad Property
- Construction Monitoring Requirements
- Utility Locates, Crossings, and Protection
- Public Safety Initiatives
- Additional Resources

Figure 2:1 Design Review Process

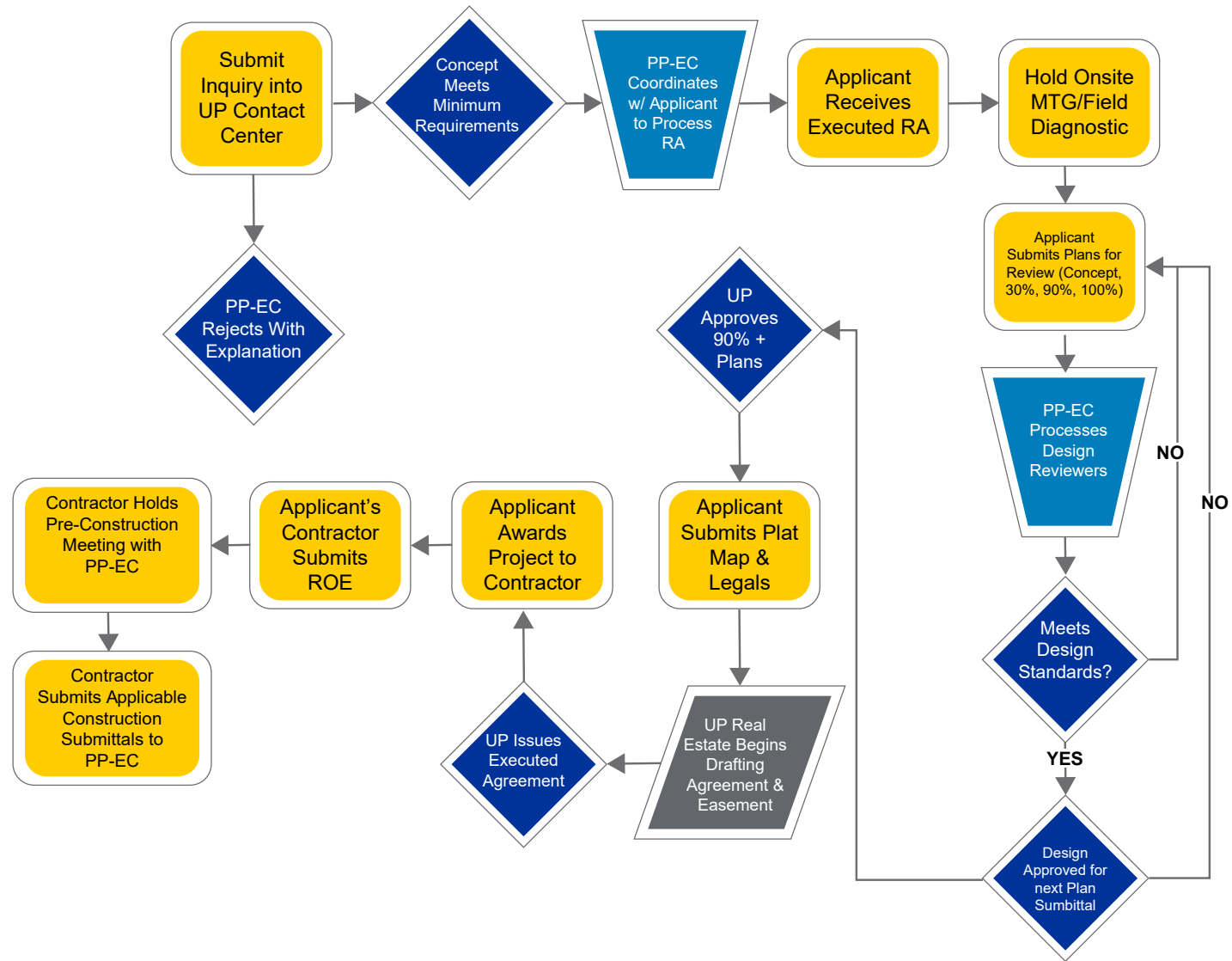

2.2 Field Diagnostic

The field Diagnostic Team meeting is the next step in the Public Project process after entering into an RA. A field Diagnostic Team meeting shall be conducted for each Public Project. The Diagnostic Team approach includes a field survey process comprised of a diverse group of experienced individuals knowledgeable in crossing design, safety, railroad operations, signaling, and traffic engineering.

The goal of this process is for this team to discuss site specific features formulating guidance and recommendations for changes at the crossing.

The Diagnostic Team also provides technical considerations in selection of project alternatives. Initial concept drawings should be prepared for use during the field Diagnostic Team review. The goal is to evaluate the appropriate hazard elimination recommendations.

2.2.1 Attendees

The onsite field Diagnostic Team meeting will be conducted with the stakeholders to assess the condition of the crossing and coordinate important safety issues. The following attendees are necessary:

- Highway agencies or authorities with jurisdiction over the roadway (The Public Road Authority with maintenance responsibility)
- Regulatory Agency with jurisdiction over the crossing, if applicable
- Representative(s) from highway agency or authority with jurisdiction of nearby intersection access to the roadway, if applicable



- Representatives from any utilities that may be affected.
- Other Local Roadway representative, if applicable (i.e., City, if the State is the Roadway Authority and City maintains traffic signals, etc.)
- Roadway designer/consultant on behalf of Applicant, if applicable
- Program manager (for larger corridor-type projects), if applicable.
- Railroad engineering representative (MPP and/or PP-EC). If more than one railroad operates on a certain track, invite each of them.
- Railroad signal maintainer, signal construction supervisor, and/or design personnel



- Introduction to this Manual
- Process Summary for Public Projects**
- Active Grade Crossing Warning Systems including Preemption Requirements
- Grade Crossings
- Grade Separation Projects
- Sidewalks and Pathways
- Parallel Corridor and Other Projects
- Quiet Zones (QZ)
- Bridge Painting, Railroad Property Beautification, and Maintenance
- Engineering Submittal Requirements and Review Schedule
- Payment of UP's Cost, Expenses and Insurance
- Agreements and Rights of Entry
- Railroad Flagging/Protection for Activities On/Near Railroad Property
- Construction Monitoring Requirements
- Utility Locates, Crossings, and Protection
- Public Safety Initiatives
- Additional Resources

- Other Railroad personnel with maintenance or other operational responsibilities, as may be necessary (MSM, MTM, etc.)
- Other Railroad owners/operators. Some Crossings are near adjacent Yard Limits that are operated by other Railroads. (including freight, industry, and LRT)
- Railroad Flagger (to provide positive train protection), if needed
- State Rail Office representative, if applicable
- Regional transportation planning organization, if applicable
- Pedestrian/bicycle coordinator, if applicable
- Representative(s) from public transit and school districts with knowledge of current and future bus routes, if applicable

Attendees should be capable of making decisions regarding design requirements, maintenance, and railroad and traffic signal operations, etc.

2.2.2 Diagnostic Review Preparation

The following items should be prepared prior to the field Diagnostic Team meeting:

- Roadway Design team – prepare the concept plan and print out the FRA Crossing Inventory sheets for the specific USDOT crossing inventory number. Complete traffic signal Preemption request and calculation forms, if applicable.
- Public Road Authority – review and provide incident reports for nearby adjacent intersections, classification, future development plans, current and projected traffic data, and any other relevant site specific information. Contact local government to discuss any current issues or concerns, including future projects. Provide design vehicle information including truck turning templates.
- Railroad (UP) – review and provide reports of broken gates and any incidents reported to UP's Response Management Communication Center (RMCC) including vehicle on track, unsafe motorist reports, unsafe pedestrian reports, etc. Review any prior Interconnect Assessment Report and the Crossing Assessment Process (CAP) information.

2.2.3 Diagnostic Review Process

Diagnostic reviews should include more items than the traditional diagnostic review that might have only reviewed the location of the grade crossing Traffic Control Devices. The Public Road Authority or Agency is responsible for generating and distributing the Diagnostic Review meeting notes.

All participants must wear proper personal protective equipment (PPE) to include a certified hardhat, reflective vest, ANSI certified eye protection and steel toe boots. Participants who do not bring proper PPE will not be permitted within 25 feet of the railroad tracks at any time during the diagnostic except to walk over the crossing as a pedestrian.

During the diagnostic it is the responsibility of the Public Authority to take detailed notes which will later be circulated and finalized by the Diagnostic Team.

The following is a partial list of diagnostic activities for each crossing.

- Review of Public Authority and railroad(s) safety statistics
- Review of current vehicular, pedestrian, bus, truck and train counts
- Observations of crossing users and any trespass activity
- Walk crossing approaches, where safe and practical
- Observe signs and pavement markings
- Discuss proposed safety measures
- State final recommendation for each crossing to be captured by note taker

At the end of each day or upon completion of the diagnostic, a wrap-up meeting will be conducted to summarize findings. This is also intended to assist the Public Authority or the note taker in capturing accurate diagnostic minutes.

Refer to **Appendix D - Crossing Diagnostic Team meeting Items and Form** for detail diagnostic review items, including agenda items and specific discussion items to document.

Introduction to this Manual

Process Summary for Public Projects

Active Grade Crossing Warning Systems including Preemption Requirements

Grade Crossings

Grade Separation Projects

Sidewalks and Pathways

Parallel Corridor and Other Projects

Quiet Zones (QZ)

Bridge Painting, Railroad Property Beautification, and Maintenance

Engineering Submittal Requirements and Review Schedule

Payment of UP's Cost, Expenses and Insurance

Agreements and Rights of Entry

Railroad Flagging/Protection for Activities On/Near Railroad Property

Construction Monitoring Requirements

Utility Locates, Crossings, and Protection

Public Safety Initiatives

Additional Resources

2.2.4 Diagnostic Team meeting Minutes

Within two to three weeks after the diagnostic, the Public Authority should circulate the meeting minutes in Microsoft Word format to the Diagnostic Team for comment. It is important that the minutes are organized, easy to follow, and that the recommendations for each crossing in the order they were reviewed at the diagnostic.

Comments from the Diagnostic Team should be returned to the Public Authority within four to six weeks, depending on the complexity of the meeting minutes provided. The final version of the meeting minutes must be circulated by the Public Authority to the Diagnostic Team.

2.2.5 Diagnostic Review Form

Many states and their Regulatory Agencies/Public Utilities Commission prefer using their own diagnostic review form during the diagnostic review (e.g., California, Texas, and Illinois). The USDOT's Highway-Rail Crossing Handbook, Figure C-2 also contains a sample questionnaire for the Diagnostic Review evaluation. If one is not available, please use the UP form provided in [Appendix D - Crossing Diagnostic Team meeting Items and Form](#).

2.2.6 State Department of Transportation and/or Regulatory Agency Requirements

Applicants should also consider that a Public Project potentially involving Railroad Property may also be subject to specific requirements of a state Department of Transportation (DOT) and/or state Regulatory Agencies. The UP PP-ECs can provide additional information regarding any state-specific project requirements for their respective territories, as appropriate.

2.3 UP Fourth Quarter Construction Moratorium

Applicants should also be mindful that UP has the right to shut down all construction activities on and adjacent to Railroad Property during the fourth quarter of each year to accommodate UP's peak holiday shipping season. An Applicant can request a waiver (sent to the PP-EC assigned to the project) from this moratorium by identifying the type of work to be performed, distance from UP track(s), and work time frame. UP can choose to waive some or all of the moratorium (construction shut down during fall only, for example) if UP determines that the construction activities will not have any impacts on UP peak train traffic. Minor work is often permitted adjacent to UP track(s), but major work (e.g., overhead bridge work) is typically not allowed by UP during the fourth quarter construction moratorium.

2.4 Approval Expiration

Written approval of Public Project submittals will be valid for two (2) years from the date of approval by the Railroad unless otherwise provided in the C&M Agreement. If construction of the approved Highway-Rail Grade Crossing, Utility Crossing or structure has not begun within this period, the Railroad shall have the right to perform a design review, at the cost of the Applicant, to confirm compliance with the Railroad's then-current Guidelines before a Railroad ROE is issued to begin construction.



BUILDING AMERICA®

UP Public Project Manual | 2-12

TOC

Introduction to this Manual

Process Summary for Public Projects

Active Grade Crossing Warning Systems including Preemption Requirements

Grade Crossings

Grade Separation Projects

Sidewalks and Pathways

Parallel Corridor and Other Projects

Quiet Zones (QZ)

Bridge Painting, Railroad Property Beautification, and Maintenance

Engineering Submittal Requirements and Review Schedule

Payment of UP's Cost, Expenses and Insurance

Agreements and Rights of Entry

Railroad Flagging/Protection for Activities On/Near Railroad Property

Construction Monitoring Requirements

Utility Locates, Crossings, and Protection

Public Safety Initiatives

Additional Resources



Section 3 Active Grade Crossing Warning Systems including Preemption Requirements

3.1 Overview

Active Grade Crossing Warning Systems are Traffic Control Devices informing road users of the approach or presence of rail traffic near At-Grade Crossings. These systems include four-quadrant gate systems, automatic gates, flashing-light signals, traffic control signals, actuated blank-out and variable message signs, and other active Traffic Control Devices.

All Traffic Control Devices and Active Grade Crossing Warning Systems must adhere to all applicable laws, regulations, and UP standards.

The highway agency or authority with jurisdiction and the Regulatory Agency with statutory authority, if applicable, jointly determine the need and selection of the Traffic Control Devices for all At-Grade Crossings. Any alterations to Active Grade Crossing Warning System must adhere to all applicable laws, regulations, and federal and state standards.

All requests to UP for a new or modified public Active Grade Crossing Warning System must be initiated by the highway agency or authority with jurisdiction, per the MUTCD, Part 8. The requesting Applicant will be responsible for securing funding of all costs associated with the installation and maintenance of the Active Grade Crossing Warning System.

The MPP and/or the PP-EC will process all projects proposing alterations to Highway-Rail Grade Crossings including, but not limited to adjusting warning systems, projects for opening new crossings, closing existing crossings, modifying or widening existing crossings, installing new warning systems, removing and/or relocating existing warning systems, and modifying or upgrading existing warning systems.

All changes to the Highway-Rail Grade Crossings, including the any Traffic Control Devices, will be subject to a project agreement as outlined in **Section 12 Agreements and Right of Entry**. It is UP's responsibility to maintain all Active Grade Crossing Warning Systems in accordance with federal, state, and local laws and regulations at the Applicant's or Public Road Authority's cost. The Railroad does not determine the adequacy of the Traffic Control Devices at Highway-Rail Grade Crossings; rather, this is determined through a Diagnostic Team meeting led by the Applicant or the Public Road Authority. The Railroad will contribute Railroad-specific information to assist agencies with their decision. See **Section 2.2 Field Diagnostic** for more information.

The coordination of traffic intersection signals with the Active Grade Crossing Warning System will be determined through a Diagnostic Team meeting led by the Applicant and the Public Road Authority.



BUILDING AMERICA®

3.2 Design Considerations

While the Diagnostic Team led by the Public Road Authority, working in conjunction with Railroad, will ultimately determine the type and location of the Active Grade Crossing Warning System, a general Guideline is provided in the MUTCD, specifically Figure 8C-1, reproduced below (Figure 3.1).

Figure 3.1 MUTCD Figure 8C-1

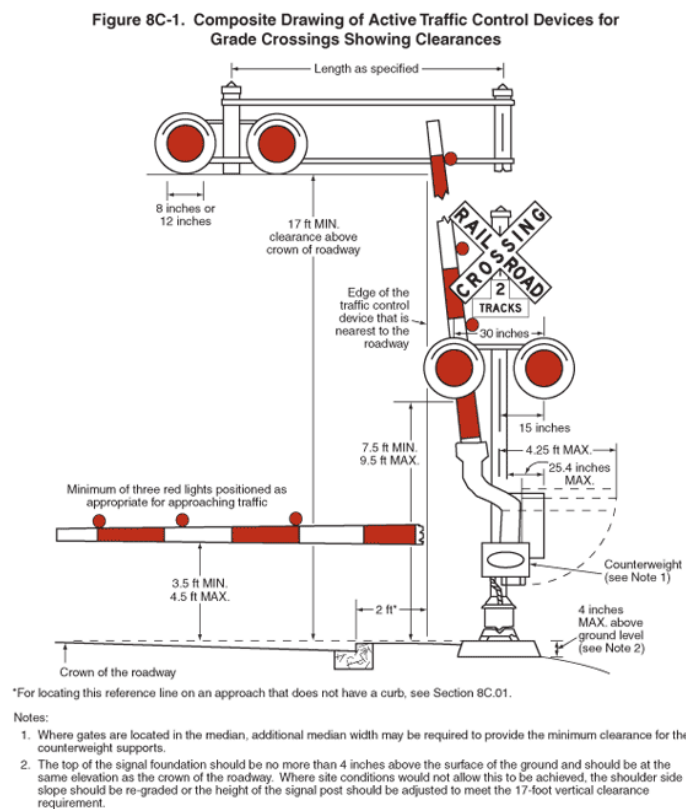

The Applicant should design the Grade Crossing layout based on these general Guidelines, although there are several additional factors to consider.

- The Railroad signal control cabinet (house or bungalow) may require upsizing or relocation. Typically these cabinets are placed a minimum of 25 ft from near rail and 30 ft from roadway travel lane in a location determined by the Diagnostic Team.
- The Active Grade Crossing Warning System (signals and gates) must be offset a minimum of 5 ft - 3 in from the face of non-mountable curb or 9 ft - 3 in from travel way. These are minimums and Diagnostic Team may require larger offsets depending upon geometrics.
- Grade Crossings with sidewalks should align the sidewalks to be at least 4.5 ft behind signal gates to prevent conflicts with the counterweight. Refer to [Appendix E - Guidance for Sidewalk Improvements](#) for more information.
- Gate lengths should be limited to UP's preferred length of 28', measured from center of mast. AREMA maximum recommended gate length is 32'. Smaller gate lengths, up to 12 ft, may not have counterweights. Medians with a minimum width of 10' could be included in the roadway design to provide a 2nd gate for wider roadways.

See [Section 10](#) for additional design information and various checklists. See [Appendix G](#) and [Appendix H](#) for Rural and Urban examples of Grade Crossing Plan Sheets.



Introduction to this Manual

Process Summary for Public Projects

Active Grade Crossing Warning Systems including Preemption Requirements

Grade Crossings

Grade Separation Projects

Sidewalks and Pathways

Parallel Corridor and Other Projects

Quiet Zones (QZ)

Bridge Painting, Railroad Property Beautification, and Maintenance

Engineering Submittal Requirements and Review Schedule

Payment of UP's Cost, Expenses and Insurance

Agreements and Rights of Entry

Railroad Flagging/Protection for Activities On/Near Railroad Property

Construction Monitoring Requirements

Utility Locates, Crossings, and Protection

Public Safety Initiatives

Additional Resources



3.3 Operation of the Active Grade Crossing Warning System

Passive Traffic Control Devices are designed to advise the Roadway users of an At-Grade Highway-Rail Crossing ahead so that users be alert for an approaching train. Active Traffic Control Devices (i.e., bells, flashing lights, and automatic gates) are designed to activate in advance of a train entering the crossing. Constant Warning Time equipment detects the approach and speed of a train and measures its distance from an At-Grade Highway-Rail Crossing in order to activate the Active Grade Crossing Warning System to provide a uniform Minimum Warning Time set forth by the Federal Railroad Administration.

3.4 Engineering, Cost Estimation, Installation, and Maintenance

The Diagnostic Team determines the location and types of traffic control devices to be installed pursuant to the MUTCD (including the possibility of Warrant 9 review), and applicable laws and regulations. Section 130 funding is available from the

Federal Highway Administration (FHWA) for crossing safety improvements and is traditionally managed by a state Public Road Authority. Active Grade Crossing Warning Systems regulate motorists and pedestrians, and are within the jurisdiction of Public Road Authorities. Therefore, they are defined by FHWA as highway control devices, not railroad signals.

Per the MUTCD and applicable law, the Railroad cannot and does not install At-Grade Crossing signals unilaterally without Public Road Authority and, if applicable, Regulatory Agency approval as the Railroad does not have the authority to regulate roadway traffic.

Installation of Traffic Control Devices must be done according to the procedures or process detailed by each state. The Railroad will design the circuitry for each crossing and estimate the cost for each project with the Applicant responsible for any and all costs incurred in completing the project. These costs include, but are not limited to, any environmental assessments, preliminary and final design, and construction of the changes necessary to complete the proposed project. Projects will not have adverse effects, delays, or restrictions on current and future freight transportation and growth, or reduction of Railroad Property that may be affected by the project.

All Railroad-specific engineering and construction must be done under the control of the Railroad, including, but not limited to, engineering, design, and cost estimates for the installation of the Active Grade Crossing Traffic Control Warning System. The Applicant is responsible for all the costs of labor and materials necessary to complete the project. The Applicant should schedule and plan accordingly for any cost estimates to take from 90 to 120 days or more depending on project complexity. The Railroad will not order material nor schedule the project until the final design is complete, a project agreement is executed, and the Applicant's Notice to Proceed has been received. Per collective bargain labor agreements, the Railroad forces will be required to install any Active Grade Crossing Warning System.

While the Railroad is responsible for the physical maintenance of the Active Grade Crossing Warning System the Roadway Authority will be financially responsible for the maintenance.

Introduction to this Manual

Process Summary for Public Projects

Active Grade Crossing Warning Systems including Preemption Requirements

Grade Crossings

Grade Separation Projects

Sidewalks and Pathways

Parallel Corridor and Other Projects

Quiet Zones (QZ)

Bridge Painting, Railroad Property Beautification, and Maintenance

Engineering Submittal Requirements and Review Schedule

Payment of UP's Cost, Expenses and Insurance

Agreements and Rights of Entry

Railroad Flagging/Protection for Activities On/Near Railroad Property

Construction Monitoring Requirements

Utility Locates, Crossings, and Protection

Public Safety Initiatives

Additional Resources

3.5 Traffic Signal Interconnect / Railroad Preemption

In order to effectively control traffic, it may be necessary to interconnect either an adjacent signalized traffic intersection, a traffic pre-signal, or traffic queue cutter signal to the Active Grade Crossing Warning System. Railroad Preemption is complex and must be designed based on the specific location. The Diagnostic Team should determine if Preemption is necessary.

Railroad Preemption of traffic signals requires careful consideration by highway traffic engineers to determine how the traffic signal and the Active Grade Crossing Warning System will provide effective traffic control. During the design stage of the Applicant's project, a Highway-Rail Grade Crossing Traffic Signal Preemption Request form must be submitted to the Railroad. This form will be provided to the Applicant immediately before or following the diagnostic and/or upon request by Applicant. UP utilizes a professional signal consultant/traffic engineer to review and provide comment to the Applicant's submittals including the Highway Rail Grade Crossing Traffic Signal Preemption Request Form, preemption calculations, wiring diagrams and the proposed project plan sheets. The submittals should include:

- Traffic signal with phasing diagrams
- Signing and Striping
- Grade crossing
- Roadway design (plan and profile)
- Any other necessary reports or studies completed for the project provided by the Applicant

A traffic signal timeline scenario worksheet may also be required.

The process for installation and activation of all signal interconnects requires careful coordination. At a minimum, UP's professional signal consultant/traffic engineer(s) will be present for bench testing and during all field installations with all costs borne by the Applicant.

The recommended practices and additional information are available in AREMA manuals, ITE's Preemption of Traffic Signals Near Railroad Crossings, USDOT's Highway-Rail Crossing Handbook, MUTCD, and any documentation developed by state or city DOTs or Regulatory Agency, where applicable. For example, the [Los Angeles DOT has a Railroad Preemption Form](#).

3.5.1 Traffic Signalized Intersection

The Public Road Authority in conjunction with any applicable regulatory agency and in accordance with the diagnostic team recommendations will determine if Preemption is warranted, in accordance with the MUTCD (including the possibility of Warrant 9 review). Pursuant to MUTCD Part 8, Railroad Preemption should be considered at a signalized intersection if motor vehicles have the queue or potential to queue over an At-Grade Crossing. Preemption should also be considered when motor vehicle traffic has the potential to queue over a Highway-Rail Grade Crossing due to other elements such as mid-block crosswalks, heavy motor vehicle traffic, geometry, etc. In these situations, queue prevention management including a queue cutter traffic signal should be considered by the Diagnostic Team to provide queue prevention over the Highway-Rail Grade Crossing.

3.5.2 Stop Controlled Intersection

Pursuant to MUTCD, Part 4, a Traffic Signal should be considered when an engineering study that includes a Traffic Signal Warrant 9, and/or associated criteria is met.

Preemption for the traffic signal may be simultaneous with, or in advance of, the Active Grade Crossing Warning System activation. (Simultaneous Preemption or Advance Preemption)

UPRR's standards align with the AREMA Manual ([Communications and Signals Manual of Recommended Practices, Volume 1, Section 3, Highway-Rail Grade Crossing Warning Systems](#)) This manual recommended practice that provides for a maximum total approach time of 50 seconds, excluding equipment response time.



Introduction to this Manual

Process Summary for Public Projects

Active Grade Crossing Warning Systems including Preemption Requirements

Grade Crossings

Grade Separation Projects

Sidewalks and Pathways

Parallel Corridor and Other Projects

Quiet Zones (QZ)

Bridge Painting, Railroad Property Beautification, and Maintenance

Engineering Submittal Requirements and Review Schedule

Payment of UP's Cost, Expenses and Insurance

Agreements and Rights of Entry

Railroad Flagging/Protection for Activities On/Near Railroad Property

Construction Monitoring Requirements

Utility Locates, Crossings, and Protection

Public Safety Initiatives

Additional Resources

3.5.3 Exit Gates and Exit Gate Management Systems

At some traffic signal crossings, a vehicle detection system is required. By union labor agreement, the Railroad or its Contractor will install and maintain all equipment related to the Highway-Rail Grade Crossing.

Annual maintenance fees for the installation and maintenance of the vehicle detection system and inductive-loop traffic detectors will be the responsibility of the Public Road Authority and invoiced by the Railroad. If utilized, the inductive-loop traffic detectors, if required, will be installed in a milled Roadway with an asphalt overlay, not saw cut into place, with all wiring connections performed by the Railroad. The vehicle detection system design, equipment, and installation will be specified and purchased by the Railroad at the sole cost and expense of the Applicant. Should the vehicle detection system fail or become damaged and no longer function, the Railroad will notify the Applicant and have them replaced at the Applicant's expense. If the Applicant proposes any changes to the vehicle detection system, the intersection configuration, or traffic timing, the Railroad must be immediately notified.

An annual joint inspection is REQUIRED to verify the health and performance of interconnected systems FRA Safety Advisory.

3.5.4 Advance Warning Device Flashing Signal Interconnect

The Diagnostic Team may recommend installation of active advance warning devices interconnected with the Active Grade Crossing Warning System. They types of devices that may be used include a sign with flashing light(s), blank out sign(s), or variable message sign(s) in accordance with the MUTCD.

3.5.5 Annual Preemption Inspection

An annual joint Railroad-Public Road Authority inspection is required to inspect the timing and operation of highway traffic signal systems that are interconnected with Active Grade Crossing Warning System to verify the traffic signal interconnection and railroad preemption is operating as designed. It is the responsibility of the Public Road Authority to prepare an inspection plan, schedule, conduct, and document these annual joint meetings.



BUILDING AMERICA®

Introduction to this Manual

Process Summary for Public Projects

Active Grade Crossing Warning Systems including Preemption Requirements

Grade Crossings

Grade Separation Projects

Sidewalks and Pathways

Parallel Corridor and Other Projects

Quiet Zones (QZ)

Bridge Painting, Railroad Property Beautification, and Maintenance

Engineering Submittal Requirements and Review Schedule

Payment of UP's Cost, Expenses and Insurance

Agreements and Rights of Entry

Railroad Flagging/Protection for Activities On/Near Railroad Property

Construction Monitoring Requirements

Utility Locates, Crossings, and Protection

Public Safety Initiatives

Additional Resources



Section 4 Grade Crossings

A Grade Crossing is any public or private Roadway that is within the Railroad's property and crosses the track. (See also the definition in the glossary for Highway-Rail Grade Crossings.) Various types of Grade Crossing projects are described in this section, including crossing surface (planking) or pavement replacements, Roadway widening or reconstruction, new Grade Crossings, temporary Grade Crossings, Grade Crossing closures, and conversions from Private Crossings to Public Crossings.

All Grade Crossing requests must be routed through the UP's **Public Project Contact Center**. Most requests will require an onsite field Crossing Diagnostic Team meeting. See **Section 2.2 Field Diagnostic** for more information.

All Grade Crossing projects including crossing surface (planking) and track work must provide a full roadway closure with a signed detour. Staged construction of the roadway that might require reversing traffic direction will not be considered.

4.1 Surface (Planking) Replacement Only

The overall ride ability of an existing Grade Crossing may become degraded based on crossing surface (planking) or pavement deterioration. Regular approach pavement maintenance is required by Road Authority to fill in potholes or mill and overlay deteriorating pavement on either side of the crossing surface (planking).

The crossing surface (planking) may also need to be replaced.

Minor maintenance projects for the Roadway approach work could be handled using the Railroad's Maintenance Consent Letter Agreement (MCL) and/or Railroad Reimbursement Agreement. The Applicant should already have a Highway-Rail Grade Crossing Agreement in place for the right for the Roadway to cross the Railroad Property. See **Section 12.1.4** and **Section 12.1.8** for additional information.

See UP Standard Drawings online https://www.up.com/emp/engineering/mapcontent/standards/0304J_PAGE_1_AND_2.pdf for figures below. Crossing Surface material may vary.

Paving approach materials may NOT deviate from UP Standard Drawings.



BUILDING AMERICA®

Figure 4.1 Plan View of Surface & Approach Pavement

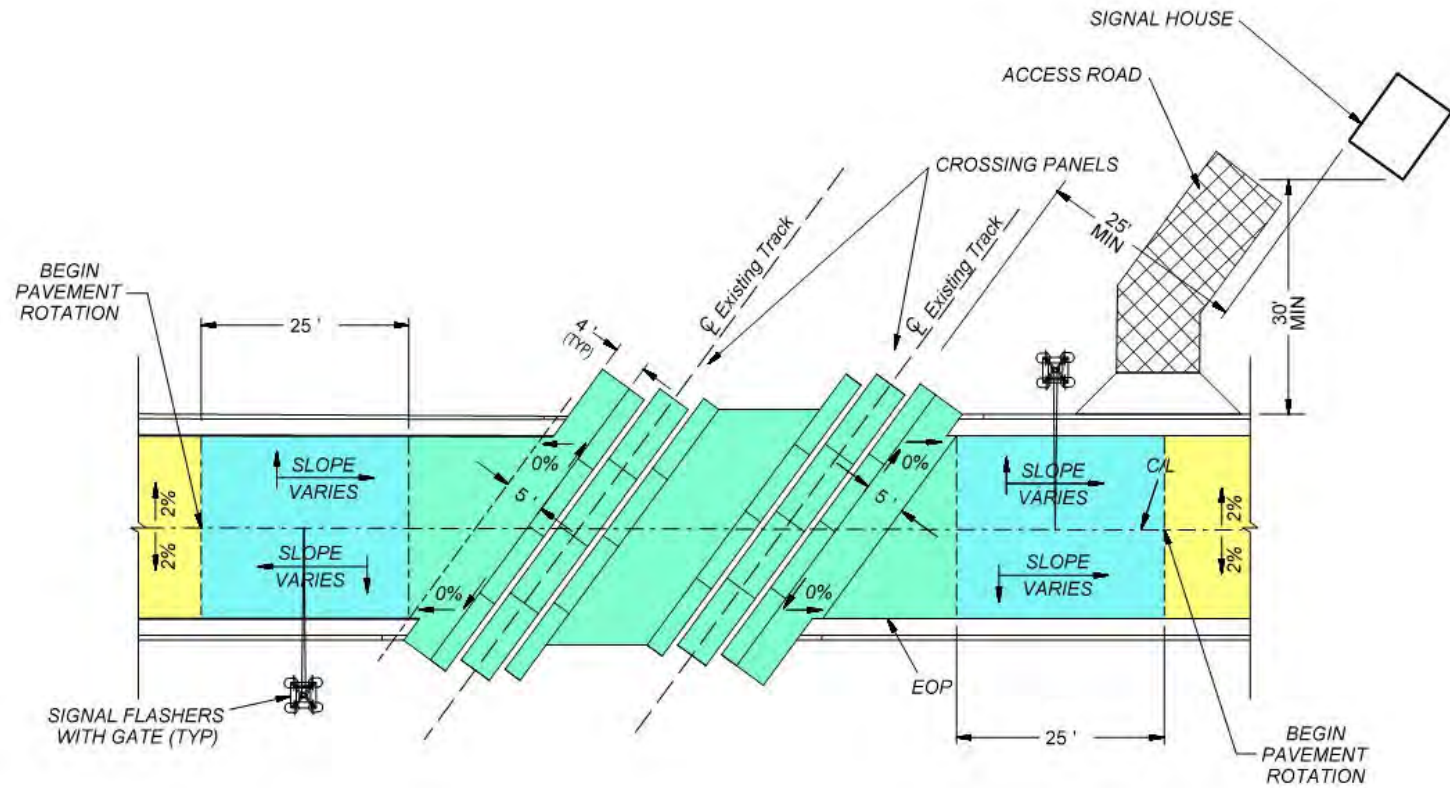

Figure 4.1

█ Depict the planar slopes matching the track crossing surface.

█ Depict the cross slope rotation areas.

█ Depict the normal crown cross slopes.

The 4 ft dimension is a parallel buffer of asphalt paving next to the crossing surface panel. This applies to all types of crossing approaches. Limits of pavement construction for a surface (Planing) replacement only should be noted in the Maintenance Consent Letter.



Figure 4.2 Typical Section of Ballast and Asphalt Detail (UP STD DWG 0304)

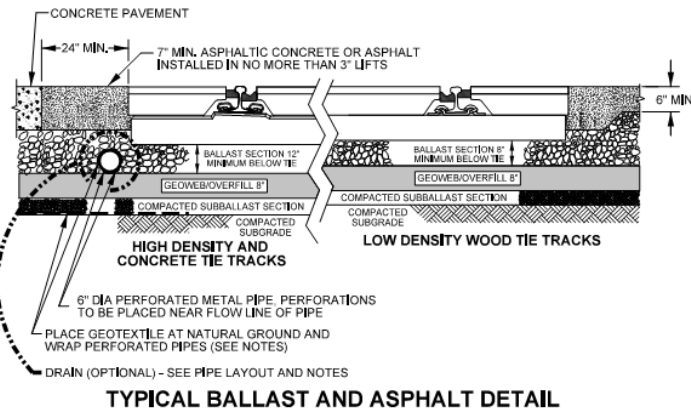
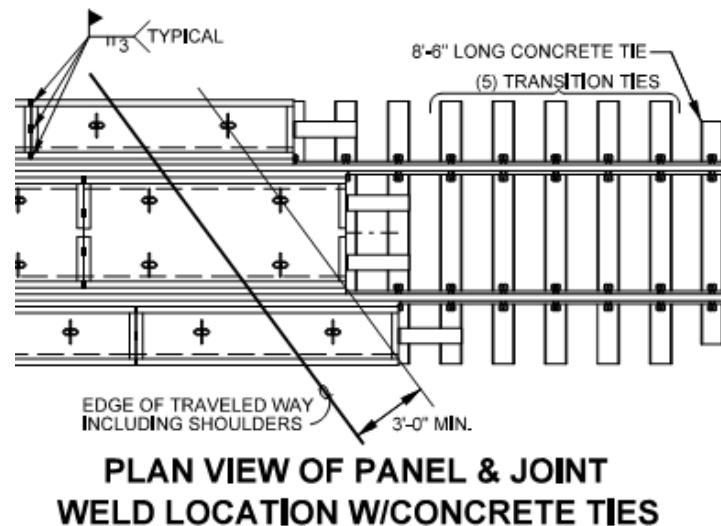

Figure 4.3 Plan View of Panel & Joint Weld Location (UP STD DWG 0304)



4.2 Roadway Reconstruction and /or Widening

The approach roadway at an existing Grade Crossing may require geometric modifications.

Some important items to consider when designing the Grade Crossing:

- A major Roadway reconfiguration or change in use will be reviewed as a New Crossing by UP. See [Appendix G](#) and [Appendix H](#) for examples of modified rural and urban Highway-Rail Grade Crossings.
- The Active Grade Crossing Warning System (signals and gates) must be offset a minimum of 5ft - 3in from the face of non-mountable curb or 9ft - 3in from travel way. See [Section 3 Active Grade Crossing Warning System including Preemption Requirements](#) for more specific information. These are minimums and crossing geometrics may require larger offsets depending upon geometrics.
- Fence placed along the Railroad ROW must not create a pinch point with the signals/gate counterweight. (Four (4ft) minimum separation from signal/gate post is recommended)
- The Railroad signal control cabinet (house or bungalow) may require upsizing or relocation. (Placed a minimum of 25ft from near rail and 30ft from roadway travel way)
- A Railroad access drive required at all four quadrants of the Grade Crossing.
- Updated surface (planking) may be required and/or extended. (increments of 8ft-1.5in or 10ft depending on panel lengths) The surface panels must extend at least 3ft past the pavement or sidewalk.
- Roadway profiles and cross slopes must be rotated to match the Grade Crossing surface. (A profile with a 5ft flat area prior to introducing a vertical curve is recommended for compaction equipment and future track resurfacing maintenance activities.)



- Introduction to this Manual
- Process Summary for Public Projects
- Active Grade Crossing Warning Systems including Preemption Requirements
- Grade Crossings**
- Grade Separation Projects
- Sidewalks and Pathways
- Parallel Corridor and Other Projects
- Quiet Zones (QZ)
- Bridge Painting, Railroad Property Beautification, and Maintenance
- Engineering Submittal Requirements and Review Schedule
- Payment of UP's Cost, Expenses and Insurance
- Agreements and Rights of Entry
- Railroad Flagging/Protection for Activities On/Near Railroad Property
- Construction Monitoring Requirements
- Utility Locates, Crossings, and Protection
- Public Safety Initiatives
- Additional Resources

- Drainage must be reviewed
- Median design should include lengths measured from the gates and the nose of median (face of curb) should be parallel to the track at a ten (10') offset from the track centerline.
- Future track requirements
- Private crossing change in use (commercial or residential expansion, multi-use)
- Full Roadway closure is required for crossing surface replacement, The minimum length of track replacement is usually 100ft without a joint
- Roadway work not completed with full road closure will require traffic phasing plans to be reviewed and approved by the Railroad

Any changes or alterations required to any of the Railroad's tracks, grading, or facilities shall be at the Public Road Authority's sole expense.

4.3 New Crossing

UP, other railroads, USDOT, and most states encourage communities to carefully consider all alternatives, including grade separations, as opposed to the request for creation of new At-Grade Crossings (public or private). The cost of a Grade Separation Project should not outweigh the enhanced safety it would provide for the traveling public. UP endorses the FHWA's stated goal of reducing the number of Grade Crossings per 23 CFR 646.214(c); and MUTCD, Section 8A.05

Every effort must be made to obtain alternative access using grade separations, parallel or other roads leading to existing crossings, and access from other directions.

Union Pacific expects communities to engage in a study to identify crossings for closure. Proposals for establishing a new At-Grade Crossing shall identify three or more crossings for closure for each proposed new crossing opened. These crossings identified shall have the same characteristics as the new proposed at-grade crossing, (i.e., similar average daily traffic / train counts, etc.). In addition, there may be specific engineering or rail operation considerations that would prevent an establishment of a new crossing.

UP's policy is not to permit private or public parallel Roadways within the Railroad's ROW, see [Section 7 Parallel Corridor & Other Projects](#).

4.3.1 Grade Crossing Safety

Nothing is more important to UP than the safety of its employees, customers, and communities. UP believes the safest crossing is no crossing, and an ongoing goal of the Railroad is to reduce the overall number of Grade Crossings to help improve safety for pedestrians, motorists, and UP employees. FRA describes goals for reducing incidents and Grade Crossing safety on its [website](#).

4.3.2 New Highway-Rail Grade Crossing Application Procedure

For safety reasons, UP insists that every entity—public or private—exhaust all options before applying for a new Grade Crossing, including construction of a new grade separated overpass crossing. Additionally, other considerations could include use of other roads leading to existing Grade Separated Crossings, other Grade Crossings, as well as access from other directions.

The Applicant should submit an online inquiry through UP's [Public Project Contact Center](#) to get the process started.

- Introduction to this Manual
- Process Summary for Public Projects
- Active Grade Crossing Warning Systems including Preemption Requirements
- Grade Crossings**
- Grade Separation Projects
- Sidewalks and Pathways
- Parallel Corridor and Other Projects
- Quiet Zones (QZ)
- Bridge Painting, Railroad Property Beautification, and Maintenance
- Engineering Submittal Requirements and Review Schedule
- Payment of UP's Cost, Expenses and Insurance
- Agreements and Rights of Entry
- Railroad Flagging/Protection for Activities On/Near Railroad Property
- Construction Monitoring Requirements
- Utility Locates, Crossings, and Protection
- Public Safety Initiatives
- Additional Resources

4.3.3 New Private Grade Crossing

Section 4.3.2 for Highway-Rail Grade Crossing procedures also apply to Private Grade Crossings, including farm, private, commercial, industrial, or Yard track crossings.

The Applicant should submit an online inquiry through UP's **Public Project Contact Center** to get the process started.

Private crossing use is strictly per the owner's lease agreement.

4.3.4 Temporary Grade Crossing / Haul-Road Crossing

Temporary haul Grade Crossings are discouraged and the Road Authority or their Contractor should explore all other access opportunities prior to making a request to the Railroad. Temporary Grade Crossings may be proposed although will be reviewed and approved on a case-by-case basis, at the sole discretion of the Railroad. A separate temporary or haul-road crossing agreement will be required. These are typically requested by the Contractor.

Any work within Railroad ROW (railroad property) or any work that may encroach within Railroad ROW or any work that has the potential to modify the use of an At-Grade Crossing, a Right of Entry is required.

When a grade crossing exists either within or in the vicinity of a traffic control plan zone, lane restrictions, flagging or other operations shall not create conditions where vehicles can be queued across the tracks. Early coordination with the Railroad should occur before work starts. The Railroad neither approves or rejects traffic control plans.

It is the responsibility of the agency to determine if the Traffic Control Plan has the potential to modify the traffic across the Grade Crossing. See **Section 4.6** for more information.

4.4 Crossing Closures and Consolidation

To enhance Highway-Rail Grade Crossing safety, UP endorses the USDOT/FHWA/FRA goal of reducing the number of at-grade crossings, both public and private, through consolidation, elimination, grade separation, and restriction of the number of new crossings installed. UP may participate in funding for crossing closures and consolidation.

The removal of the crossing should include the following:

1. The Applicant will install the appropriate temporary road closure barriers and advance signing.
2. The Applicant will remove all the paving on the approaches to the edge of the Grade Crossing surface (planking).
3. UP will remove the Active Grade Crossing Warning System, conduits, foundations, and Grade Crossing surface (planking), and will change the ties to be uniform with the track approach ties.
4. The Applicant will revise the finished grading to remove any parallel drainage pipes and will establish a continuous ditch. (There should not be a hump in grading to indicate there was ever a Roadway.)
5. The Applicant will redesign each roadway approach to install the appropriate vehicle (e.g. garbage truck and emergency vehicle) turn around, per the local agency standards. This can be either a circular area (as shown in **Figure 4.5**) or a hammer-head type configuration at the end of a street approach to allow vehicles to turn around.
6. Provide sufficient pedestrian re-routing using various methods, including fencing, to prevent trespassing after roadway is closed.
7. Under certain circumstances, an alternative minimum closure option (**Figure 4.4**) is allowed provided the Applicant will install the permanent end of road barriers and object markers per **UP Standard Drawing 0310 – Type IV Barricade for Road Crossing Closure**.
8. Additional ROW fence may be required to secure the Railroad property and prevent trespassers.

- Introduction to this Manual
- Process Summary for Public Projects
- Active Grade Crossing Warning Systems including Preemption Requirements
- Grade Crossings**
- Grade Separation Projects
- Sidewalks and Pathways
- Parallel Corridor and Other Projects
- Quiet Zones (QZ)
- Bridge Painting, Railroad Property Beautification, and Maintenance
- Engineering Submittal Requirements and Review Schedule
- Payment of UP's Cost, Expenses and Insurance
- Agreements and Rights of Entry
- Railroad Flagging/Protection for Activities On/Near Railroad Property
- Construction Monitoring Requirements
- Utility Locates, Crossings, and Protection
- Public Safety Initiatives
- Additional Resources

Figure 4.4 Road Closure – Rural (Minimum)

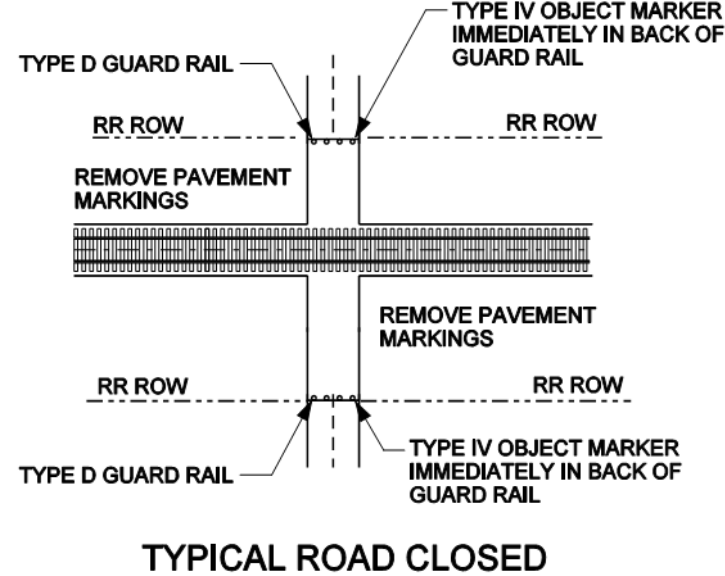
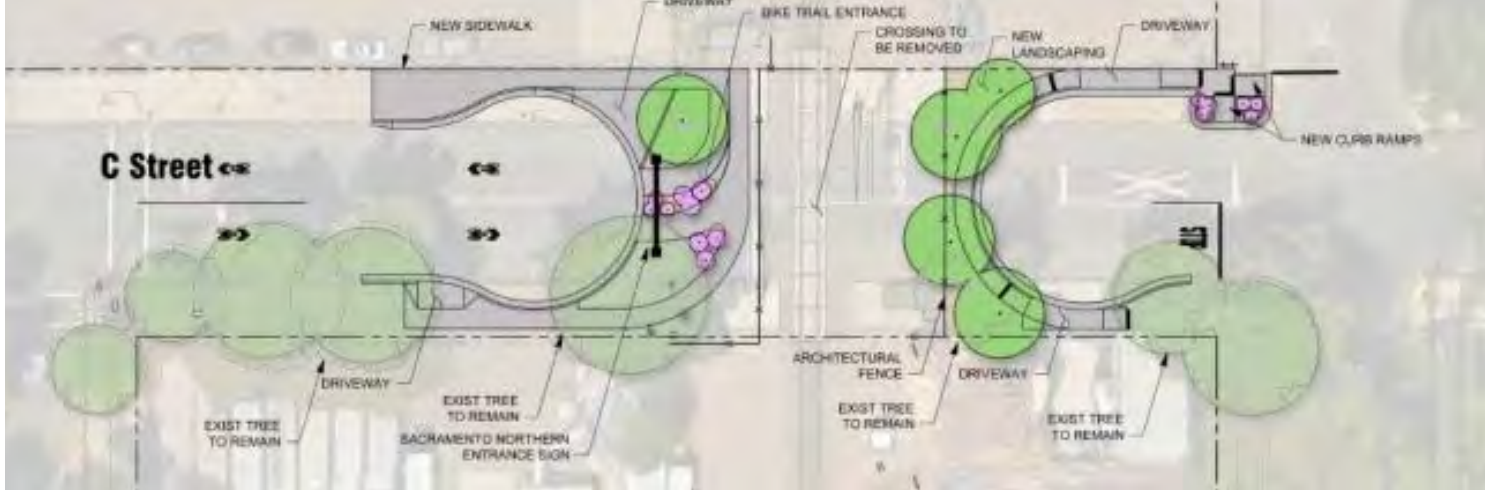

Figure 4.5 Road Closure – Urban with Cul-de-sac



4.5 Conversion of Private Crossing to Public

The process for converting a Private Crossing to a Public Crossing is the same as requesting a new installation of a Public Crossing, as discussed in [Section 4.3.3](#). The real estate agreement for the Private Crossing's use would be terminated and a new agreement established.

4.6 Temporary Traffic Control in Proximity to Highway-Rail Grade Crossing

Some projects that are outside the Railroad ROW need to be aware that staged construction of a roadway with traffic shifted to the opposite side of the existing travel lanes will not be allowed through any Highway-Rail Grade Crossing.

All Highway-Rail Grade Crossing construction will require a full closure of the roadway within the Railroad ROW. Any work within Railroad ROW (railroad property) or any work that may encroach within Railroad ROW or any work that has the potential to modify the use of an At-Grade Crossing, a Right of Entry is required.

When a grade crossing exists either within or in the vicinity of a temporary traffic control plan zone, lane restrictions, flagging or other operations shall not create conditions where vehicles can be queued across the tracks. Early coordination with the Railroad should occur before work starts. The Railroad neither approves nor rejects traffic control plans.

It is the responsibility of the Public Road Authority to determine if the Temporary Traffic Control Plan has the potential to modify traffic across the Grade Crossing.

- Public Road Authority to determine if the proposed temporary traffic control plan has the potential to cause queuing or have any other impacts to vehicular movements over UPRR tracks in accordance with Parts 6 and 8 of the MUTCD. If there is existing queuing, the potential for on-track queuing is possible, or other impacts to vehicular movements are identified, at a minimum, the Public Road Authority shall coordinate with the UPRR PPEC for submission of temporary traffic control plans

and statement of queue prevention mitigation plans, including, but not limited to:

- Roadway flagger(s) upstream of the crossing to prevent queuing on tracks at all times. Show roadway flagger symbol on plans at approximate location and private flagger warning sign on the plans pursuant to MUTCD.
- Installation of "DO NOT STOP ON TRACKS" (R8-8) sign(s) at the crossing.
- Railroad flagger (if needed).
- Verification of any other anticipated impacts to adjacent UPRR crossings due to the proposed temporary traffic control. For example, is the proposed temporary traffic control causing vehicles to reroute to an adjacent UPRR grade crossing? If so, list the adjacent UPRR grade crossings that are being impacted with DOT# and a description of planned traffic mitigations.

Rerouting vehicle traffic to drive counterflow across a grade crossing is typically not allowed by UPRR. When allowed, both RR and roadway flaggers would be required 24 hours/day and throughout the duration of counterflow conditions.

Temporary traffic control plans should include:

- All traffic control devices and layout to conform to the latest MUTCD standards
- Verification that motorists' visibility to existing railroad warning devices and signage will be maintained at all times during construction
- Provide vehicle, pedestrian, and bicycle detours
- Verification of proper vehicle turning movements towards or away from the crossing are accommodated for by the largest design vehicle including turning movements at closely spaced intersections and driveways. Include turning movement templates on plans. Restrict movements if needed



- Verification that existing preemption timing and railroad interconnection will be maintained at all times during construction. Road Authority shall coordinate any work affecting grade crossing operations including existing preemption timing and railroad interconnection to an adjacent signalized intersection.

4.7 Grade Crossing Maintenance Responsibilities

The Railroad is only responsible for maintaining the track roadbed, signal house and track surface/planking. The Public Road Authority is responsible for the maintenance of the roadway approach paving, shoulders, medians, curb and gutter, sidewalks, and warning devices shown in red color. See **Figure 4.6** below:

Figure 4.6 Roadway Crossing Maintenance Limits

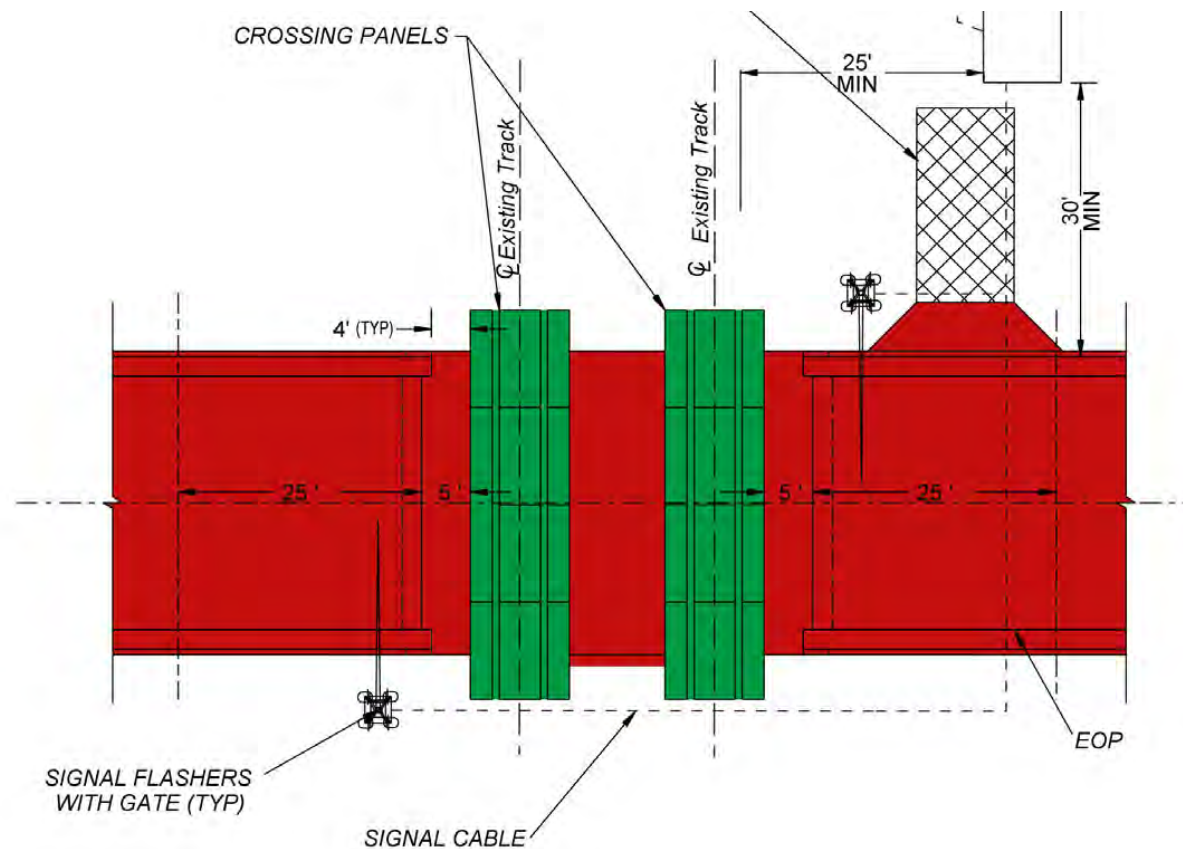



Section 5 Grade Separation Projects

5.1 Overview

Grade Separation Projects are a means of eliminating At-Grade Crossings by constructing Overpass Grade Separations and Underpass Grade Separations. This construction benefits the public by eliminating the potential for train-vehicle collisions and increasing the fluidity of traffic. Given the common need to expand rail operations, it is crucial that the Railroad has the ability to expand its network in the future as business demands require. All design plans for Grade Separation Projects, starting at the conceptual stage, must be reviewed and approved by the Railroad.

The Railroad should be involved early in the project development process to allow required standards to be incorporated into the design of the project.

Figure 5.1 Grade Separation Elevation

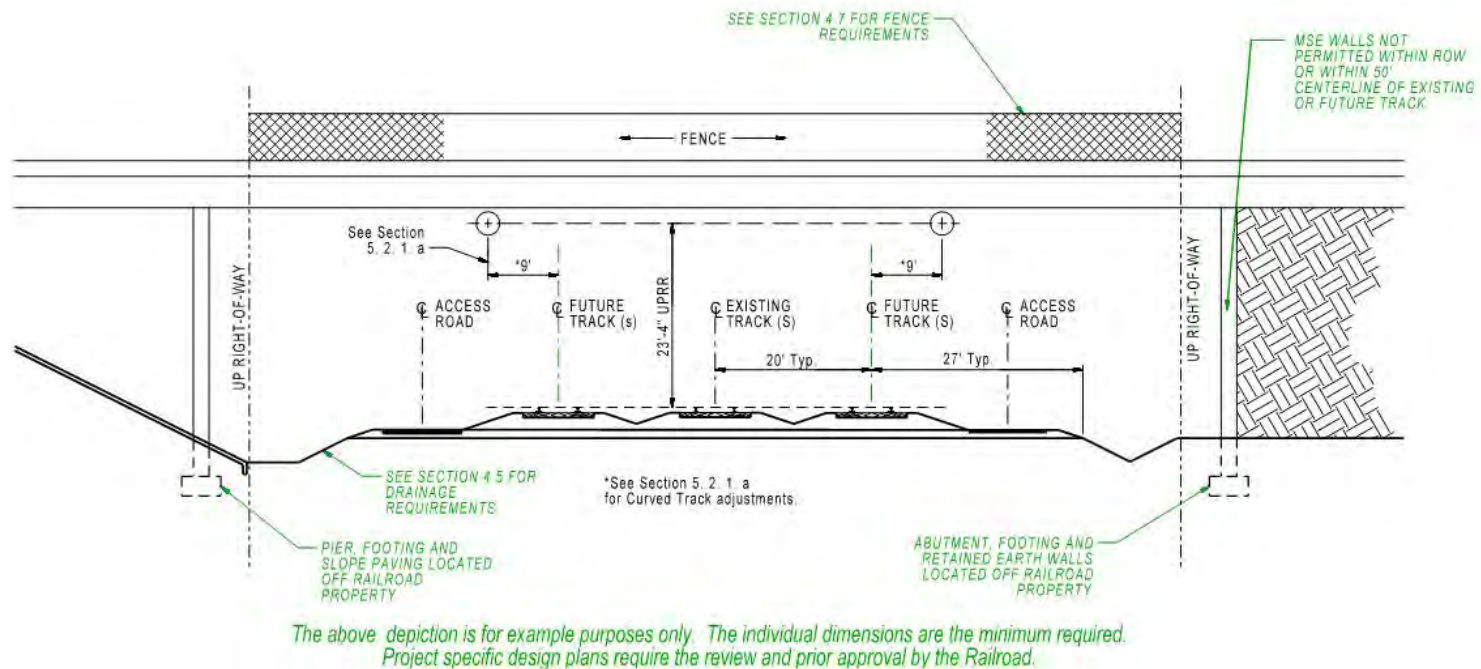

- Introduction to this Manual
- Process Summary for Public Projects
- Active Grade Crossing Warning Systems including Preemption Requirements
- Grade Crossings
- Grade Separation Projects**
- Sidewalks and Pathways
- Parallel Corridor and Other Projects
- Quiet Zones (QZ)
- Bridge Painting, Railroad Property Beautification, and Maintenance
- Engineering Submittal Requirements and Review Schedule
- Payment of UP's Cost, Expenses and Insurance
- Agreements and Rights of Entry
- Railroad Flagging/Protection for Activities On/Near Railroad Property
- Construction Monitoring Requirements
- Utility Locates, Crossings, and Protection
- Public Safety Initiatives
- Additional Resources

As outlined in the joint UP and BNSF Railway (BNSF) **Guidelines for Railroad Grade Separation Projects**, all new Overpass Grade Separation structures (including existing bridge replacements) must span UP's ROW and have a minimum 23-foot, 4-inch Vertical Clearance above the Top of Rail. Furthermore, all Grade Separation Projects must provide accommodations for future operating needs, as determined by the Railroad.

In accordance with Section 2 and Section 10 of this Manual and per the UP and BNSF **Guidelines for Railroad Grade Separation Projects**, Grade Separation Projects will be coordinated by the MPP and/or the PP-EC, including review by various other internal parties. Projects included will be all those that involve the installation of new grade separation structures, removal and/or reconstruction of existing grade separation structures, and modification of grade separation structures. During the review process, the MPP and the assigned PP-EC shall be the points of contact for the Applicant's Grade Separation Project. All design and construction submittal reviews and coordination will be at the cost of the Applicant.

All Grade Separation Projects must comply with the UP and BNSF Guidelines for Railroad Grade Separation Projects.

The Grade Separation Project shall be designed and phased to execute a work plan that enables the track(s) to remain in service and shall cause no interruption to Railroad operations during construction. The roadway below will need to be closed and detoured during the Grade Separation Project's construction. The detour must be reviewed and approved by the local agencies and should consider the increased traffic on the surrounding roadway network and traffic signals; the type of roadway detour needed (state route detour for a state route); notification timelines for coordinating with the public, etc.

5.2 Key Understandings

Key understandings for Grade Separation Projects include the following:

- UPRR does not allow Underpass Grade Separation structures. Every effort should be made to design and construct an Overpass Grade Separation structure rather than an Underpass Grade Separation structure. Additional specific justification for an Underpass Grade Separation structure will be required at the concept phase and must be approved by the Railroad prior to proceeding into preliminary design. (This includes a conceptual design of an Overpass Grade Separation structure that reflects how an overpass is not feasible.)

Any variance to the Railroad standards and guidelines will likely result in added project time and cost to the Applicant's project.

- The Railroad requires a Structure Type Selection Report for any new and reconstructed grade separation. The Railroad does not allow interruption to railroad operations. Any interruption to Railroad operations must include justification. See **Appendix K** for more information on UP's Review Guidelines.
- The Railroad requires that all bridge features, piers, footings, retaining walls, and slope protection be placed outside the UP property.
- Existing bridge encroachments into the Railroad ROW does not constitute the right to perpetuate an encroachment. Any major bridge change, including widening, will require removal of any existing bridge encroachments.
- Reduced temporary construction clearances, which are less than the specified construction clearances, will require special review and prior approval. Special reviews are considered a variance and there is no time limit on how long it takes to progress a variance and approvals could take months to years. If a variance request is approved, they are subject to re-review and rejection prior to construction.

- Introduction to this Manual
- Process Summary for Public Projects
- Active Grade Crossing Warning Systems including Preemption Requirements
- Grade Crossings
- Grade Separation Projects**
- Sidewalks and Pathways
- Parallel Corridor and Other Projects
- Quiet Zones (QZ)
- Bridge Painting, Railroad Property Beautification, and Maintenance
- Engineering Submittal Requirements and Review Schedule
- Payment of UP's Cost, Expenses and Insurance
- Agreements and Rights of Entry
- Railroad Flagging/Protection for Activities On/Near Railroad Property
- Construction Monitoring Requirements
- Utility Locates, Crossings, and Protection
- Public Safety Initiatives
- Additional Resources

- Any Grade Separation Project should be designed to minimize potential interruptions to Railroad operations (e.g. using precast components and avoiding cast in place). Proposed construction phasing shall be reviewed.
- Mechanically Stabilized Earth (MSE) walls are not acceptable for support of a Railroad embankment. Additionally, MSE walls supporting Roadways above track level are not acceptable within the Railroad Property or within 50 feet of the centerline of an existing or future track or any closer than 15' of Railroad ROW.
- Railroad ditches are not designed or intended for conveyance of public water. For projects that change drainage on Railroad Property, temporary and final drainage plans and capacities must be submitted, reviewed, and accepted by the Railroad. Plans shall provide drainage away from the Railroad ROW.
- Access to the Railroad Property must be maintained at all times before, during, and after construction.
- All demolition that may impact Railroad tracks or operations shall comply with the requirements in UP's ***Guidelines for Preparation of a Bridge Demolition and Removal Plan for Structures Over Railroad***.
- The attachment of any public or private utility, such as a wireline, pipeline, or similar, to a Railroad structure is prohibited.
- The Applicant shall submit as-built drawings and supporting documents for all structures to the MPP or PP-EC after completion of the bridge structure and prior to closeout of the Grade Separation Project.
- All new Overpass Grade Separations, including those without Sidewalks, shall include protective fencing along exterior edges of the structure in accordance with UP and BNSF ***Guidelines for Railroad Grade Separation Projects***.

- Any existing structure with the express intent to convey a watershed, must not be altered to provide unauthorized vehicle crossings. This includes adding trails, access drives or pathways that could be utilized by snowmobiles, ATVs, motocross, golf carts, side by sides, bicycles, pedestrians, etc. These uses would require a new crossing, which is not supported, and a new DOT Number.

Cost alone should not be the determining factor in alternative analyses or requests for design variances for an Applicant's project.

5.3 Temporary and Permanent Construction Clearances

The information in this section is summarized from the UP and BNSF ***Guidelines for Railroad Grade Separation Projects*** pertaining to temporary and permanent construction clearances. See those Guidelines for current information regarding these clearances.

5.3.1 Permanent Clearances

All Grade Separation Projects shall include permanent clearance to accommodate future Railroad tracks, future track raises, maintenance Access Roads, and adequate drainage. The proposed permanent Vertical Clearance and horizontal clearance shall be established and possibly adjusted to account for the sight distance to any train control wayside signal. If sight clearance cannot be established and the train control wayside signal must be renewed in an alternative location, the cost associated is the responsibility of the Applicant of the Grade Separation Project.

Introduction to this Manual

Process Summary for Public Projects

Active Grade Crossing Warning Systems including Preemption Requirements

Grade Crossings

Grade Separation Projects

Sidewalks and Pathways

Parallel Corridor and Other Projects

Quiet Zones (QZ)

Bridge Painting, Railroad Property Beautification, and Maintenance

Engineering Submittal Requirements and Review Schedule

Payment of UP's Cost, Expenses and Insurance

Agreements and Rights of Entry

Railroad Flagging/Protection for Activities On/Near Railroad Property

Construction Monitoring Requirements

Utility Locates, Crossings, and Protection

Public Safety Initiatives

Additional Resources



Photo: Wheaton over UP's Geneva Subdivision

5.3.2 Permanent Vertical Clearance (Under an Overpass Grade Separation)

The minimum permanent Vertical Clearance shall be 23 feet, 4 inches measured from the top of the highest rail to the lowest obstruction under the structure. The extent of the permanent Vertical Clearance shall be a minimum of 9 feet, 0 inches to the field side of the outermost existing or future track, measured perpendicular to the centerline of said tracks. In curved track, the above minimum extent of 9 feet shall be increased either 6 inches total or 1.5 inches for every degree of curve, whichever is greater. Added Vertical Clearance may be required for adjustment of sag in vertical curve, future track raise, flood considerations, and construction and maintenance purposes.

5.3.3 Permanent Horizontal Clearance (Under an Overpass Structure)

The Railroad requires all piers and abutments to be located outside the Railroad ROW limits. More clearance may be required for additional future tracks, track spacing and track shifts, or maintenance Access Roads. See the UP and BNSF

Guidelines for Railroad Grade Separation Projects for additional details. Where it is impossible to clear span the Railroad ROW, the Applicant shall provide written justification and request for variance for the proposed design. The request should succinctly describe geometric, structural, and other constraints that make a clear-span alternative unfeasible and shall show that all options have been exhausted. Cost alone should not be the determining factor.

5.3.4 Permanent Vertical Clearance (Under an Underpass Structure)

All Underpass Grade Separations structures shall be designed to ensure that the structure will be protected underneath from oversized or unauthorized loads by providing sufficient Vertical Clearance and protective devices unless otherwise specified by the Railroad. This includes providing a minimum Vertical Clearance over the entire Roadway width for all new or reconstructed structures as follows:

1. 16 feet, 6 inches for steel superstructure with five or more beams, or four or more deck plate girders per track
2. 17 feet, 6 inches for concrete superstructure or steel through plate girders with bolted bottom flanges
3. 20 feet, 0 inches for steel through plate girders without bolted bottom flanges

The Vertical Clearance must not be violated due to the deflection of the superstructure, use of a sacrificial impact protection device, or any other reason. Additional Vertical Clearance may be required by the Railroad. Variance from Vertical Clearances defined above shall require prior review by the Railroad. The variance request shall provide exhaustive justification. Cost shall not be the determining factor. If resurfacing or any other activity is to be performed below the underpass structure, the Public Road Authority must submit a request for approval from the Railroad. This request must provide the existing measured and posted clearances of the structure and the proposed configuration after work is completed.

- Introduction to this Manual
- Process Summary for Public Projects
- Active Grade Crossing Warning Systems including Preemption Requirements
- Grade Crossings
- Grade Separation Projects**
- Sidewalks and Pathways
- Parallel Corridor and Other Projects
- Quiet Zones (QZ)
- Bridge Painting, Railroad Property Beautification, and Maintenance
- Engineering Submittal Requirements and Review Schedule
- Payment of UP's Cost, Expenses and Insurance
- Agreements and Rights of Entry
- Railroad Flagging/Protection for Activities On/Near Railroad Property
- Construction Monitoring Requirements
- Utility Locates, Crossings, and Protection
- Public Safety Initiatives
- Additional Resources

5.3.5 Permanent Horizontal and Vertical Clearances (on an Underpass Structure)

Permanent horizontal and Vertical Clearances on an Underpass Grade Separation structure shall conform to the requirements of AREMA, Manual for Railway Engineering, Chapter 15, Part 1, and the UP and BNSF [Guidelines for Railroad Grade Separation Projects](#), Section 6.9.5. In curved track, the Horizontal Clearances shall be increased either 6 inches total or 1.5 inches for every degree of curve, whichever is greater. Proposed structures that accommodate multiple tracks, both future and existing tracks, with spacing less than 20 feet shall be designed for a minimum of 20-foot spacing measured centerline to centerline.

5.3.6 Sacrificial Impact Protection Devices

All structures with Vertical Clearances less than defined in the UP and BNSF [Guidelines for Railroad Grade Separation Projects](#) shall be protected with a sacrificial device on each side of the structure. Protection may be in the form of a redundant steel or concrete fascia beam. Diaphragms connecting the redundant beam to the adjacent beams shall be designed to limit their impact and damage, if struck, to the adjacent beams. Concrete fascia beams used as walkways shall be installed adjacent to the proposed structure and may also serve as a sacrificial beam. If a concrete fascia beam is used as a sacrificial beam, it shall have a 6-inch by 6-inch by 1-inch embedded steel angle and shall be adequately anchored to the bridge seats.

5.3.7 Temporary Vertical Clearance

Temporary horizontal and vertical construction clearances shall be shown on the plans for all Grade Separation Projects. A minimum temporary vertical construction clearance of 21 feet, 6 inches measured above top of high rail for all tracks shall be provided. The required minimum temporary Vertical Clearance shall not be violated due to deflection of formwork. All overhead wirelines should meet the requirements for temporary clearances found in the UP and BNSF [Guidelines for Railroad Grade Separation Projects](#)

5.3.8 Temporary Horizontal Clearance

A minimum temporary horizontal construction clearance of 15 feet, 0 inches, measured perpendicular from the centerline of the nearest track to all physical obstructions, including, but not limited to, formwork, stockpiled materials, parked equipment, bracing, or other construction supports, shall be provided. In curved track, the temporary horizontal construction clearances shall increase either 6 inches total or 1.5 inches for every degree of curve, whichever is greater. Temporary horizontal construction clearance shall provide sufficient space for drainage ditches parallel to the standard roadbed section or shall provide an alternative system that maintains positive drainage.

5.4 Temporary Shoring

All required temporary shoring shall meet the requirements of UP's [Guidelines for Temporary Shoring](#). The Contractor must not begin construction of any component of the shoring system affecting the Railroad ROW until written Railroad approval has been received.

5.5 Shoofly or Detour Track Design

In many cases, design of a temporary track detour, commonly called a Shoofly track, will be required to maintain rail operations during underpass bridge projects. All costs associated with the Shoofly design, construction, and removal will be the Applicant's responsibility. UP will perform all connections to the Mainline Track.

UP will require a Shoofly phasing design layout similar to the example [Shoofly Phasing Plan](#) online. A full design plan set with plan, profile, typical sections, details, cross sections, and special provisions will be required in addition to the phasing plan. The Shoofly track design should meet the Mainline Track speed. The construction of the Shoofly track should minimize Mainline Track outages or disruptions. See UP's [Technical Resources for Public Projects](#) for more information.

Introduction to this Manual

Process Summary for Public Projects

Active Grade Crossing Warning Systems including Preemption Requirements

Grade Crossings

Grade Separation Projects

Sidewalks and Pathways

Parallel Corridor and Other Projects

Quiet Zones (QZ)

Bridge Painting, Railroad Property Beautification, and Maintenance

Engineering Submittal Requirements and Review Schedule

Payment of UP's Cost, Expenses and Insurance

Agreements and Rights of Entry

Railroad Flagging/Protection for Activities On/Near Railroad Property

Construction Monitoring Requirements

Utility Locates, Crossings, and Protection

Public Safety Initiatives

Additional Resources

5.6 Pathway Grade Separations



Photo: San Obispo Parkway over UP

Per the UP and BNSF [Guidelines for Railroad Grade Separation Projects](#), Section 7, Trails, Pathways will require grade separation from the railroad. Railroad structures are not permitted for Pathway use and crossing. New and existing overhead structures must be designed or modified with protective fencing to prevent objects and debris thrown on the Railroad ROW or at passing trains. Underpass Grade Separation structures that also serve to convey water are not permitted. Dependent on specific site characteristics signs and lighting may also be required.

5.7 Roadway Signs and Utilities Installed on UP Bridges

The attachment of Signs to any Railroad structure is discouraged unless the Signs are directly related to traffic safety. Clearance Signs, advance warning Signs, and other Roadway Signs are generally acceptable with the understanding that they are the maintenance responsibility of the Public Road Authority. These Signs may be attached by the Public Roadway Authority with written concurrence from, plan approval by, and coordination with the MPP or PP-EC. The Signs, mounting fixtures, and related attachments must not interfere with the integrity, clearances, or accessibility of the structure. The attachment of temporary Signs to UP bridges is prohibited.

Lighting of the Railroad ROW may be part of the Public Project, depending on overhead bridge width, and should be maintained by the Road Authority.

No utility or non-traffic safety Sign attachments will be permitted on underpass structures. Existing or future fiber optic lines shall be placed underground and away from bridge structures.

5.8 Maintenance Responsibilities

The Applicant shall own, maintain and replace the proposed Overpass Grade Separation or Underpass Grade Separation at no cost to the Railroad and with no interruption to Railroad operations during construction, maintenance and future replacement of the grade separation, reference the UP and BNSF Guidelines for Railroad Grade Separation Projects. For both grade separation types the Applicant is responsible for graffiti abatement, painting, drainage and snow removal. All drainage runoff and snow removal should be directed away from the Railroad's property. Furthermore the Applicant is responsible for trash and debris removal, fencing included with the project and the removal of trespassers in the vicinity of any structure.

- Introduction to this Manual
- Process Summary for Public Projects
- Active Grade Crossing Warning Systems including Preemption Requirements
- Grade Crossings
- Grade Separation Projects**
- Sidewalks and Pathways
- Parallel Corridor and Other Projects
- Quiet Zones (QZ)
- Bridge Painting, Railroad Property Beautification, and Maintenance
- Engineering Submittal Requirements and Review Schedule
- Payment of UP's Cost, Expenses and Insurance
- Agreements and Rights of Entry
- Railroad Flagging/Protection for Activities On/Near Railroad Property
- Construction Monitoring Requirements
- Utility Locates, Crossings, and Protection
- Public Safety Initiatives
- Additional Resources

5.8.1 Overpass Grade Separation Maintenance

For Overpass Grade Separations, maintenance shall include all maintenance, repair, renewal, seismic retrofits, barrier rail replacement, deck repairs, and inspection, all at the Applicant's expense. Activities requiring design reviews and possibly an Agreement modification, include deck replacement, bridge widening with new piers, addition of access drives, major culvert extensions, etc.

The Applicant is responsible for the entire structure including, although not limited to, the superstructure, substructure, piers, abutments, walls, barrier rails, approaches, grading, drainage, lighting and any sidewalks as included with the new Overpass Grade Separation structure. Care should be taken to avoid snow from being plowed on to the Railroad property.

5.8.2 Underpass Grade Separation Maintenance

For Underpass Grade Separations, maintenance shall include all maintenance, repair, renewal, and inspection, all at the Applicant's expense. The Railroad will have maintenance responsible from above the waterproofing on the structure which generally includes the ballast, railroad tracks and signals. The Applicant is responsible for the entire structure including, although not limited to, the superstructure, substructure, piers,

abutments, walls, approaches, grading, waterproofing and drainage, including any necessary pumps/lift stations, as required for the new structure. See [Appendix I](#) for full image of Figure 5.2 below.

5.9 Summary

Each state DOT and/or Regulatory Agency may have its own requirements for grade separation structures and appropriate clearances. It is recommended that research be conducted to determine any specific requirements. Any infringement within state statutory clearances due to the Applicant's (or its Contractor's) operations must be submitted to the MPP and PP-EC. Construction must not commence until the Railroad has received any necessary written authorization from the appropriate state Road Authority for the variance. No compensation will be allowed if the Applicant's work is delayed pending Railroad approval, and/or the state Road Authority or Regulatory Agency approval. The UP and BNSF [Guidelines for Railroad Grade Separation Projects](#) have detailed information regarding the design requirements for the various types of overpasses or underpasses. See UP's [Grade Separation Bridge Projects website](#) for more information.

Figure 5.2 Agency Grade Separation Ownership & Maintenance Responsibilities

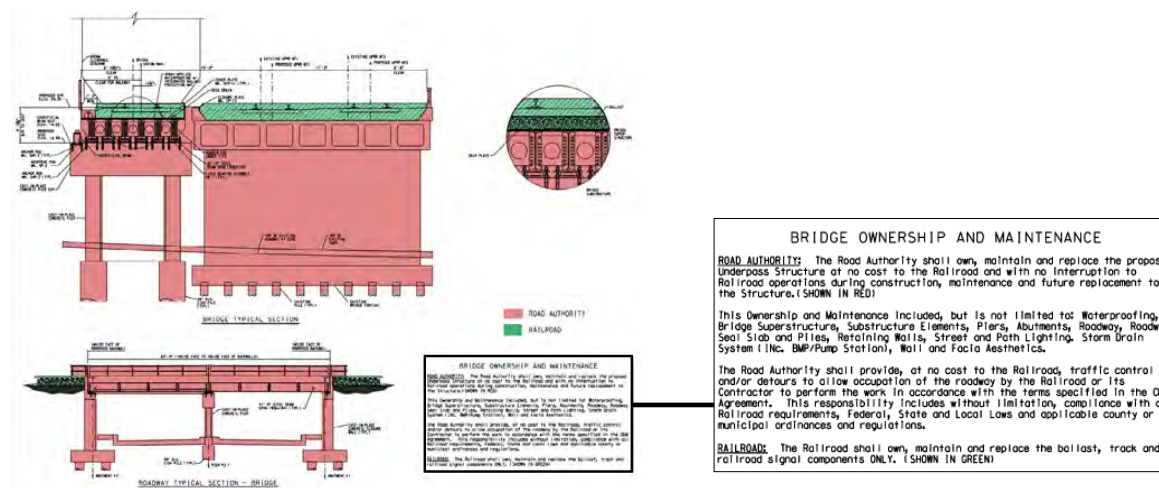

- Introduction to this Manual
- Process Summary for Public Projects
- Active Grade Crossing Warning Systems including Preemption Requirements
- Grade Crossings
- Grade Separation Projects
- Sidewalks and Pathways**
- Parallel Corridor and Other Projects
- Quiet Zones (QZ)
- Bridge Painting, Railroad Property Beautification, and Maintenance
- Engineering Submittal Requirements and Review Schedule
- Payment of UP's Cost, Expenses and Insurance
- Agreements and Rights of Entry
- Railroad Flagging/Protection for Activities On/Near Railroad Property
- Construction Monitoring Requirements
- Utility Locates, Crossings, and Protection
- Public Safety Initiatives
- Additional Resources



Section 6 Sidewalks and Pathways

6.1 Sidewalks

Proposed Sidewalks are reviewed by UP's Public Projects Group. Similar to Highway-Rail Grade Crossings and Grade Separation Projects, a PP-EC will be assigned to shepherd the project through the review process.

The figure below is only one example of a Sidewalk combined with the adjacent Roadway. Specific site conditions may warrant alternative Traffic Control Devices.

Figure 6.1 Guidance for Sidewalk Improvements

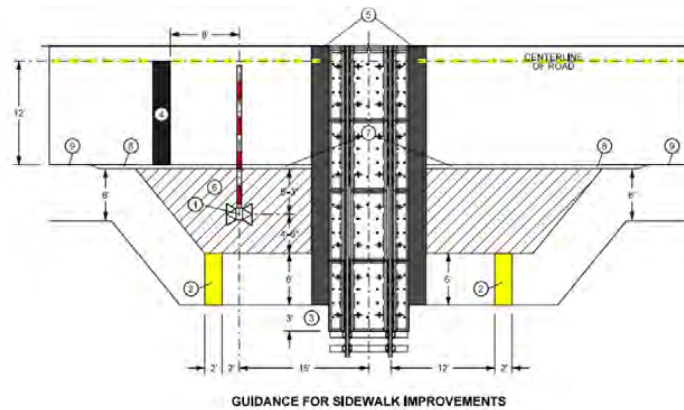

The alignment of the Sidewalk should be as close to perpendicular to the tracks as possible. If the Sidewalk is 25 feet or more away from the edge of Traveled Way of the Roadway, it is considered a separate crossing.

Sidewalks and the Diagnostic review's recommended Warning Device placement should be designed per the MUTCD. UP offers additional guidance in the [Appendix E Guidance For Sidewalk Improvements](#) as it relates to warning device placement.

Only Sidewalk Grade Crossings immediately adjacent to an existing public Highway-Rail Grade Crossing equipped with an Active Grade Crossing Warning System will be considered. Passive Warning Devices may be considered although only in unique situations.

Although the MUTCD allows Sidewalks to be placed in front of the Active Grade Crossing Warning System, UP will not allow this design. UP design preference provides Sidewalks to be placed behind the Active Grade Crossing Warning System at a sufficient distance to not interfere with the gate counterweights. Typically, UP recommends at least 4' from the signal/gate post center to the nearest edge of the sidewalk surface.

6.2 Bicycle/Pedestrian Pathways

UP does NOT allow new At-Grade Pathway Grade Crossings. Alternative plans should be considered to avoid crossing Railroad tracks at-grade. The addition of a bicycle lane or separate pedestrian Pathway should be reviewed for inclusion in the Highway-Rail Grade Crossing immediately adjacent, similar to a Sidewalk. Pathways parallel to the Railroad (inside the Railroad ROW) are not allowed. UP does not allow the use of the Railroad Access Roads for Pathway purposes.

A Railroad structure cannot be used to serve Pathway traffic or support a structure serving Pathway traffic. Similarly, Pathways under a Railroad waterway Structure will not be approved. See [Section 5.6](#) for more detail.

Fences or barriers such as vegetation, ditches, and/or berms shall separate Pathways that are outside the Railroad ROW and running parallel to the track to stop trespassers from entering the ROW.

UP will NOT permit any stand-alone recreational Pathways to cross the Railroad tracks at grade for safety reasons.

- Introduction to this Manual
- Process Summary for Public Projects
- Active Grade Crossing Warning Systems including Preemption Requirements
- Grade Crossings
- Grade Separation Projects
- Sidewalks and Pathways**
- Parallel Corridor and Other Projects
- Quiet Zones (QZ)
- Bridge Painting, Railroad Property Beautification, and Maintenance
- Engineering Submittal Requirements and Review Schedule
- Payment of UP's Cost, Expenses and Insurance
- Agreements and Rights of Entry
- Railroad Flagging/Protection for Activities On/Near Railroad Property
- Construction Monitoring Requirements
- Utility Locates, Crossings, and Protection
- Public Safety Initiatives
- Additional Resources

6.3 Multi-Use or Recreational Pathways

UP does NOT permit private or public multi-use or recreational parallel Pathways within the Railroad ROW.

Recreational stand-alone Pathways will not be permitted to cross the Railroad tracks, at grade, for safety reasons. This includes motorcycle, all-terrain vehicle (AV), and horseback riding trails.

The scope of the proposed Pathway crossing work will be determined by a field Diagnostic Team meeting with knowledgeable representatives of parties of interest in a Highway-Rail Grade Crossing, using crossing safety management principles, to evaluate conditions at a grade crossing to make determinations or recommendations concerning safety needs at the grade crossing. The diagnostic team needs to, at a minimum, include representatives of the Roadway Authority with jurisdiction over the roadway, UP, and any state Regulatory Agency with statutory authority over grade crossings. See [Section 2.2 Field Diagnostics](#), for more information.

All costs associated with the installation of new or modified crossing surface (Planking), and modification or relocation of Active Grade Crossing Warning System, including maintenance, will be borne by the Applicant.

Establishing new Pathways over the railroad track and ROW, not adjacent to existing public Roadways, will require an Overpass Grade Separation structure. Any Pathway over the railroad will require fence to prevent individuals from throwing or jumping onto the tracks.

New Pathways requested across an existing UP bridge or under an existing UP bridge will not be allowed. Grade Separations intended for hydraulic conveyance will not be considered a viable location for a new trail or pedestrian pathway. In rare occasions, new Pathway requests will be considered with the following:

- A hydrologic and hydraulic study, flood elevation for 50-year and 100-year events.
- Concept showing a canopy for falling debris protection extending a minimum of 30 feet on each side of the Railroad structure.

Trails requiring retaining walls or significant excavation adjacent to abutments/piers could lead to over-stressed bridge components and/or failure and will not be allowed. UP does not support the installation of Pathway underpasses.

See the UP and BNSF [Guidelines for Railroad Grade Separation Projects](#), Section 7, Trails, for more specific Guidelines. See also [Section 5, Grade Separation Projects](#), in this Manual for more information.

Trail and sidewalk geometric designs should conform to the Federal-Aid Policy Guide (FAPG) and meet ADA guidelines.

Introduction to this Manual

Process Summary for Public Projects

Active Grade Crossing Warning Systems including Preemption Requirements

Grade Crossings

Grade Separation Projects

Sidewalks and Pathways

Parallel Corridor and Other Projects

Quiet Zones (QZ)

Bridge Painting, Railroad Property Beautification, and Maintenance

Engineering Submittal Requirements and Review Schedule

Payment of UP's Cost, Expenses and Insurance

Agreements and Rights of Entry

Railroad Flagging/Protection for Activities On/Near Railroad Property

Construction Monitoring Requirements

Utility Locates, Crossings, and Protection

Public Safety Initiatives

Additional Resources



Section 7 Parallel Corridor and Other Projects



Photo Source: UP's Sunset Route in Mecca, CA

7.1 Overview

This section generally addresses Applicant sponsored projects that include parallel Roadways on or adjacent to UP ROW. UP's policy is not to permit private or public parallel Roadways within Railroad ROW. This section also generally addresses other types of projects not mentioned elsewhere in the Manual. For example, Alternate Delivery, commuter or transit type projects.

In the interest of public safety, parallel public roads shall be located off UP ROW. Parallel roads involving intersections with existing or proposed Roadways, where Public Crossings or Private Crossings are present, should be aligned to provide sufficient distance from the Grade Crossing for the largest vehicle (Design Vehicle) permitted to use the road. The Design Vehicle shall be able to stop between the Railroad and the parallel road

traffic control Signs, markings, and other Traffic Control Devices without interfering with Railroad operations, obstructing or preventing the operation of Traffic Control Devices, or obstructing the Grade Crossing in any manner. Commercial properties adjacent to Railroad Property must consider the impacts to railroad crossings during development and construction.

7.2 General Guidelines

The design of highways, highway intersections, and configuration of Highway-Rail Grade Crossings is the responsibility of the Applicant. Drainage for highway runoff, the Railroad corridor, and adjacent property must be designed to reduce or maintain existing Railroad drainage and to prevent standing water and potential erosion. Access to UP equipment, Railroad Property, structures, and track cannot be restricted or prevented.



BUILDING AMERICA®

- Introduction to this Manual
- Process Summary for Public Projects
- Active Grade Crossing Warning Systems including Preemption Requirements
- Grade Crossings
- Grade Separation Projects
- Sidewalks and Pathways
- Parallel Corridor and Other Projects**
- Quiet Zones (QZ)
- Bridge Painting, Railroad Property Beautification, and Maintenance
- Engineering Submittal Requirements and Review Schedule
- Payment of UP's Cost, Expenses and Insurance
- Agreements and Rights of Entry
- Railroad Flagging/Protection for Activities On/Near Railroad Property
- Construction Monitoring Requirements
- Utility Locates, Crossings, and Protection
- Public Safety Initiatives
- Additional Resources

Federal and state design manuals, the MUTCD, and AREMA provide additional recommended practices and design information to be considered by the Applicant responsible for the project engineering.

Any changes or alterations required of any of the Railroad's tracks, grading, or facilities shall be at the Public Road Authority's sole expense.

7.3 Key Considerations

Key considerations for parallel corridor projects include the following:

- Parallel roads need to be located off Railroad ROW. Encroachments are not allowed without an approved Lease Agreement.
- The figure below shows a Roadway Encroachment being moved outside of Railroad ROW. For larger scale example, See [Appendix J – Sample Parallel Street Encroachment](#).

Figure 7.1 Plan View of Parallel Encroachment Removed

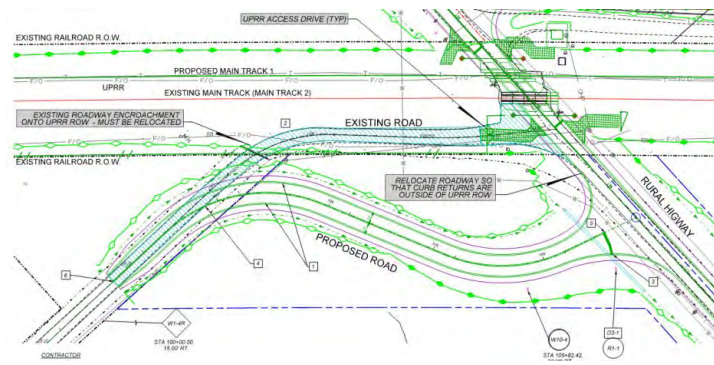

- Parallel roads must not restrict Railroad access to its ROW, tracks, or other facilities.

- Parallel utility construction work that might impact the Railroad must be reviewed and approved by the Railroad. This includes facilities that are centered outside the ROW but require excavation into the ROW. See [Section 15 Utility – Locates, Crossings and Protection](#) and [Section 12.2.6 ROE - Encroachment](#) for more information.
- Any requests for a parallel road on any part of Railroad Property must be made online through the [Public Project Contact Center](#). This will include entering into an [RA](#) as described in [Section 12.1.1](#) and providing detailed proposed Roadway concept layouts.
- Railroad and road drainage must be taken into account and approved by the Railroad. Installation of drainage features may temporarily encroach onto Railroad ROW, as shown in the figure below.

Figure 7.2 Section View of Drainage on Parallel Highway

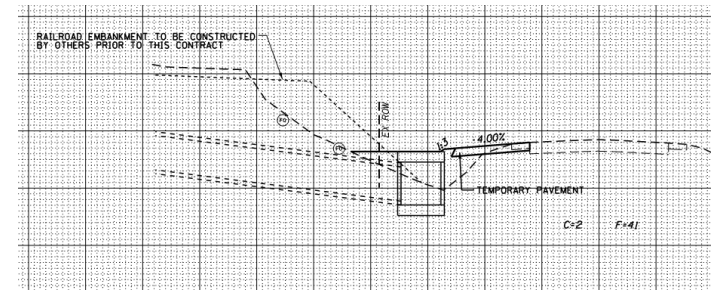

Public Projects should follow the Drainage Criteria shown in [Appendix K](#).

- Retaining walls proposed parallel to the Railroad ROW shall be reviewed by the Railroad. The location of these walls should be sufficiently offset from the Railroad ROW to prevent Encroachment during maintenance operations. The construction of retaining walls may require cranes that, if compromised, could fall within 25 feet of the track. The Applicant would require a ROE and Flagger during all construction operations involving the cranes.

Introduction to this Manual

Process Summary for Public Projects

Active Grade Crossing Warning Systems including Preemption Requirements

Grade Crossings

Grade Separation Projects

Sidewalks and Pathways

Parallel Corridor and Other Projects

Quiet Zones (QZ)

Bridge Painting, Railroad Property Beautification, and Maintenance

Engineering Submittal Requirements and Review Schedule

Payment of UP's Cost, Expenses and Insurance

Agreements and Rights of Entry

Railroad Flagging/Protection for Activities On/Near Railroad Property

Construction Monitoring Requirements

Utility Locates, Crossings, and Protection

Public Safety Initiatives

Additional Resources

7.4 Commercial Developments or Parallel Project Environmental Reviews

UP should be contacted to review development studies and construction drawings for projects adjacent to Railroad ROW. This includes being notified in advance of submitting environmental studies to other public or permitting agencies. For example, an Environmental Impact Statement (EIS) or a 408 permitting application. Developers submitting plans to local Roadway Authority planning departments should also provide their plans to UP for review and comment. UP has a process outlined in [Section 1.5.2](#) to review all Public Notices that may affect railroad ROW or grade crossings and failure to give notice to the Railroad may cause delay or modifications to the planned development. Impacts to Grade Crossing use will require a diagnostic, see [Section 2](#).

7.5 Levee / Flood Walls

Any existing embankment located on Railroad property should not be considered a certified levee nor used to control flood waters in any way. The Railroad discourages the construction of any levees or flood walls on Railroad property. Furthermore, levees or flood walls constructed parallel to railroad property are discouraged and effort should be made to construct any levee or flood wall so the Railroad is located on the dry side of the structure. After all design alternatives are considered and the only option is to construct a levee to cross the Railroad property / ROW, the feasibility of elevating the railroad tracks to the design elevation should first be considered. The Applicant should design a gradual gradation slope taking into account train dynamics. The Railroad will require the review and approval of any proposed grade changes. Only after all options are thoroughly evaluated will the Railroad consider a closure structure to traverse over Railroad property or tracks.

The following considerations should be made when designing any closure structure.

- Any structure must be reviewed and approved by the Railroad.
- All costs associated with any closure structure, including any required Railroad work, will be the responsibility of the Applicant.
- Must exceed the Railroad's minimum horizontal clearance requirements and requires the Railroad's approval.
- Should be designed to minimize any interruptions to railroad operations.
- Must not be in contact with the railroad tracks in anyway causing a potential shunt.
- The structure will be tied into the Railroad's existing signal system requiring design by the UP signal group.
- The Railroad's tracks should not be directly affixed to any of the portion of closure structure like the sill for example.
- The closure structure can be manually installed or mechanically installed during a flood event with type selection dependent based on minimizing interruptions to train operations and as approved by the Railroad.
- A detailed operations and maintenance (O&M) manual must be developed to contain the following:
 - List of responsible parties for the operation and maintenance of the closure structure
 - Upstream flood monitoring.
 - Protocol detailing the installation procedures including step by step process with step duration documented.
 - Detailed communication plan.
 - Detailed maintenance plan.
 - Process and schedule for practicing installation of the closure structure.

See example closure structure in a Mainline Track application on the next page.



BUILDING AMERICA®

Introduction to this Manual

Process Summary for Public Projects

Active Grade Crossing Warning Systems including Preemption Requirements

Grade Crossings

Grade Separation Projects

Sidewalks and Pathways

Parallel Corridor and Other Projects

Quiet Zones (QZ)

Bridge Painting, Railroad Property Beautification, and Maintenance

Engineering Submittal Requirements and Review Schedule

Payment of UP's Cost, Expenses and Insurance

Agreements and Rights of Entry

Railroad Flagging/Protection for Activities On/Near Railroad Property

Construction Monitoring Requirements

Utility Locates, Crossings, and Protection

Public Safety Initiatives

Additional Resources

Figure 7.3 3D Model of Flood Wall Gate Closure

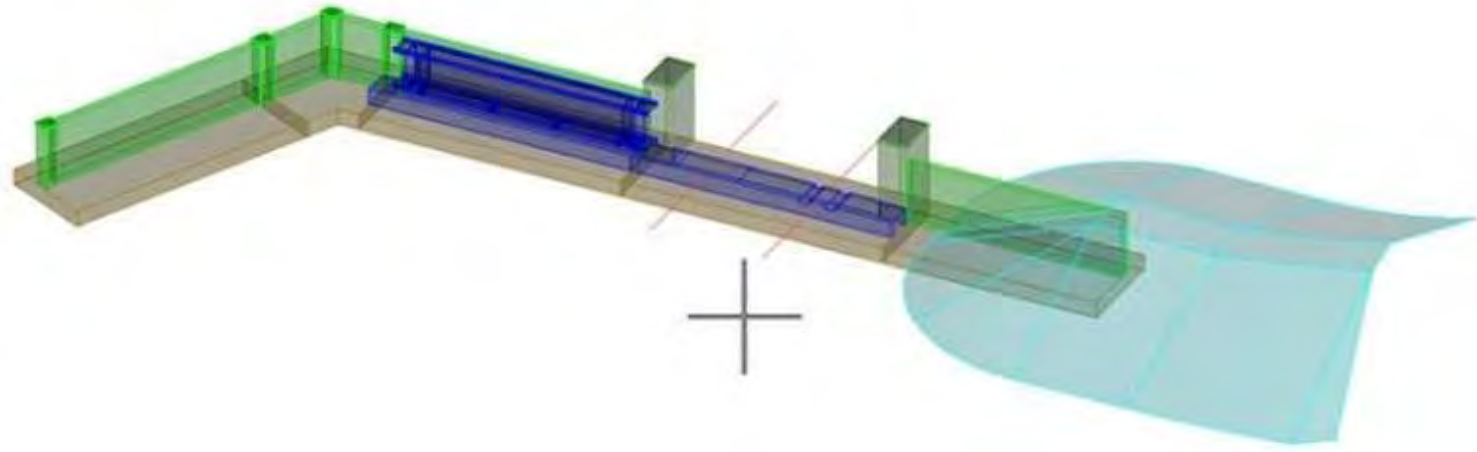
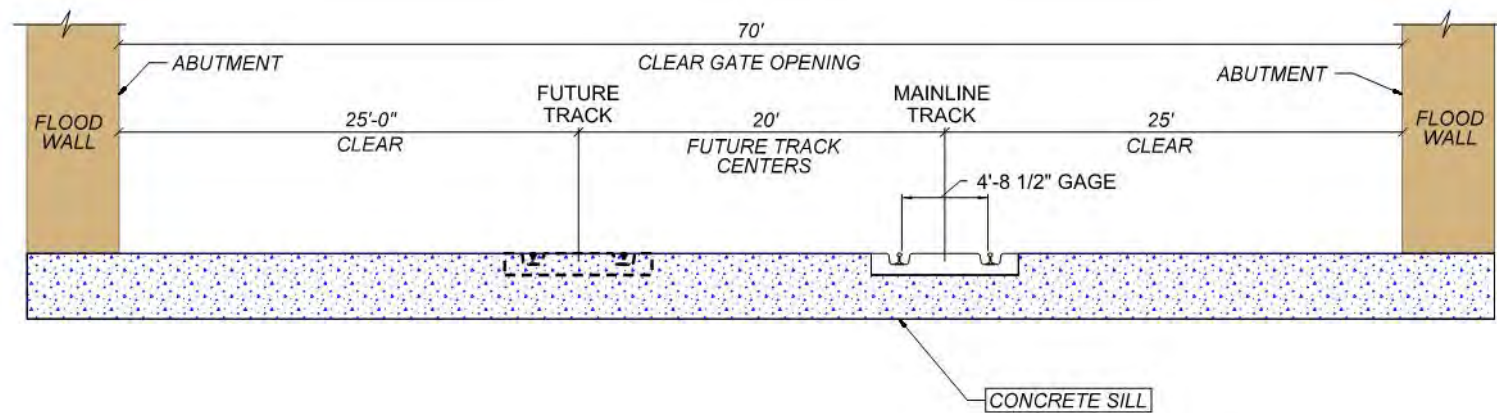

Figure 7.4 Section of Flood Wall Gate Closure



BUILDING AMERICA®

- Introduction to this Manual
- Process Summary for Public Projects
- Active Grade Crossing Warning Systems including Preemption Requirements
- Grade Crossings
- Grade Separation Projects
- Sidewalks and Pathways
- Parallel Corridor and Other Projects**
- Quiet Zones (QZ)
- Bridge Painting, Railroad Property Beautification, and Maintenance
- Engineering Submittal Requirements and Review Schedule
- Payment of UP's Cost, Expenses and Insurance
- Agreements and Rights of Entry
- Railroad Flagging/Protection for Activities On/Near Railroad Property
- Construction Monitoring Requirements
- Utility Locates, Crossings, and Protection
- Public Safety Initiatives
- Additional Resources

7.6 Alternative Delivery

Many Applicants are pursuing alternate project delivery methods rather than the traditional design-bid-build approach. Common alternative delivery projects types are design-build, with subsets design-build finance and design-build operate, construction manager/general contractor (CM/GC), construction management-at-risk (CM-at-risk), public private partnerships (P3). Applicants wanting to use alternative delivery methods to design and construct their infrastructure projects that use alternative delivery methods should reference the best practices developed by the UP. These best practices will help public entities achieve their desired objective of accelerating project delivery while recognizing UP's primary focus on safely moving freight with minimal impact to operational efficiency.

Construction on Railroad Property will only be allowed when 100% Design Plans are approved by the Railroad and a Right of Entry is issued.

The Best Practices: Coordinating with Union Pacific in Alternative Delivery Projects document can be found on the [UP Website](#).

7.7 Commuter / Passenger Transit Projects

Commuter rail service can provide substantial benefits to the public, including reducing traffic congestion and avoiding expensive highway construction. Nevertheless UP has a responsibility to the nation and to its customers to protect the public benefits of freight transportation: energy efficiency, lower emissions, cost-effective cargo transportation for shippers and consumers, and private investment in the nation's infrastructure. UP has developed Commuter Access Principles to guide commuter rail planners and agencies with the Railroad to develop new rail passenger service. This can be found in [Appendix L](#).

Any changes or alterations required of any of the Railroad's tracks, grading, or facilities shall be at the Public Road Authority's or Applicant's sole expense.

7.7.1 Commuter Design

All elements of commuter rail projects shall meet all UP, AREMA and FRA design standards and requirements. Every effort should be made to design the top of platform elevation to be at the same or lower elevation as the Top of Rail. Clearance requirements will be determined for all tracks both during and after construction. Platforms shall be designed to serve one side of the track. Platforms will not be located within a curve. Center platforms will not be allowed unless there is an Overpass Grade Separation, adhering to the [Guidelines for Railroad Grade Separation Projects](#), to provide access to the center platform. All proposed platforms shall be a minimum of 300 Feet from any Grade Crossing. The Applicant is responsible for all actual project costs, including maintenance fees associated with the commuter project. All proposed modifications to existing station platforms, station building, roofing, etc. must be submitted to Public Projects, for review. See [Section 2](#) Process Summary for Public Projects, for more information.

Introduction to this Manual

Process Summary for Public Projects

Active Grade Crossing Warning Systems including Preemption Requirements

Grade Crossings

Grade Separation Projects

Sidewalks and Pathways

Parallel Corridor and Other Projects

Quiet Zones (QZ)

Bridge Painting, Railroad Property Beautification, and Maintenance

Engineering Submittal Requirements and Review Schedule

Payment of UP's Cost, Expenses and Insurance

Agreements and Rights of Entry

Railroad Flagging/Protection for Activities On/Near Railroad Property

Construction Monitoring Requirements

Utility Locates, Crossings, and Protection

Public Safety Initiatives

Additional Resources



Section 8 Quiet Zones (QZ)

Please recognize UP is of the opinion that sounding the locomotive horn at highway-rail grade crossings enhances safety whereas QZs increase risk to motorists, pedestrians and trespassers. At a minimum, a diagnostic to evaluate the proposed QZ is recommended and safety treatments should be implemented at each crossing which can include Supplemental Safety Measures (SSM) and/or Alternative Safety Measures (ASM).

The federal regulation concerning train horns is officially known as the Train Horn Rule 49 CFR Part 222 or Quiet Zone Rule. The final rule became effective on June 24, 2005. This Rule requires the train horn to be sounded for 15 to 20 seconds before a locomotive enters a public at-grade crossing, but not more than a quarter mile in advance. The federal requirement preempts any state or local laws regarding the use of train horns at public crossings.

8.1 Quiet Zone Rule

The entity responsible for creating a QZ must be a highway agency or Authority with jurisdiction over the roadway, referred to as the Public Authority in Quiet Zone Rule. Quiet Zone Rule outlines the criteria to establish and maintain a QZ. The most common QZs are full or partial. In a full QZ, the train horn is silenced 24 hours per day. In a partial QZ, the horn is silenced between the hours of 10:00pm and 7:00am.

Upon the successful implementation of a QZ, it should be recognized that although trains will cease routine sounding of the horn at Grade Crossing(s), there are numerous situations when

sounding of the horn will be required. For example, a locomotive engineer will exercise discretion to sound the horn for safety purposes when pedestrians or workers are in proximity of the Grade Crossing(s) and when necessary to comply with any other train operating rules.

The Public Authority should refer to the FRA's [website](#) where links can be found to the [Guide to the QZ Establishment Process](#) and the final [Rule](#). The following is an abbreviated version of the process to establish a QZ at UP crossings.

It should be noted that the QZ process can be very complex and technical. If this is the Public Authority's first QZ, it may be advisable to seek the services of a consulting firm or other resource that has experience with the QZ process.

8.2 Minimum Requirements for a QZ

8.2.1 Minimum Length

The QZ must be a minimum of one-half mile in length along the length to the Railroad ROW.

8.2.2 Active Warning Devices

Each Public At-Grade Crossing must be equipped with Active Grade Crossing Warning System comprising of both Flashing-Light Signal and gates which control traffic over the crossing and that conform to the standards contained in the MUTCD. Such Active Grade Crossing Warning System shall be equipped with Constant Warning Time devices, if reasonably practical, and power-out indicators.

8.2.3 Advance Warning Signs

Each approach to every Public and Private At-Grade Crossing within the QZ shall be equipped with MUTCD compliant advance warning signs that advise the motorist that train horns are not sounded at the crossing.



BUILDING AMERICA®

- Introduction to this Manual
- Process Summary for Public Projects
- Active Grade Crossing Warning Systems including Preemption Requirements
- Grade Crossings
- Grade Separation Projects
- Sidewalks and Pathways
- Parallel Corridor and Other Projects
- Quiet Zones (QZ)**
- Bridge Painting, Railroad Property Beautification, and Maintenance
- Engineering Submittal Requirements and Review Schedule
- Payment of UP's Cost, Expenses and Insurance
- Agreements and Rights of Entry
- Railroad Flagging/Protection for Activities On/Near Railroad Property
- Construction Monitoring Requirements
- Utility Locates, Crossings, and Protection
- Public Safety Initiatives
- Additional Resources

8.2.4 Bells

Where crossings are equipped with bells and subjected to pedestrian traffic, the bells must be retained and maintained in working condition.

8.2.5 Private or Pedestrian Crossings

Private or pedestrian crossings within the boundaries of a QZ must be included in the QZ, evaluated by a diagnostic team and equipped or treated in accordance with the recommendations of the diagnostic team. At a minimum, each approach to every private crossing requires an MUTCD compliant crossbuck and "STOP" sign to be installed at the expense of the Public Authority. Both private and pedestrian crossings must be equipped with MUTCD compliant advance warning signs advising that train horns are not sounded.

8.2.6 MUTCD Compliance

All public crossings within the QZ must be in compliance with the requirements of the MUTCD.

8.3 How to Initiate a QZ at UP Crossings

The first step to establish a QZ is to submit a request to the **UP Public Projects Contact Center**. The Quiet Zone Rule requires the QZ process to be initiated and progressed by the Public Authority or their representative. Requests from citizens or developers must go through the Public Authority.

Upon receipt of a verified request, UP will assign a QZ consultant to the project. The consultant will perform preliminary research to assess the complexity of the project. This information will be used to estimate UP costs to participate in the QZ process. Once this information is gathered, the Public Authority will be contacted to discuss the QZ process described in this section and cost estimates.

If the Public Authority agrees to proceed, a Reimbursement Agreement must be executed by the Public Authority to reimburse UP for the engineering services required to manage the QZ project. After the agreement is executed, the following is a high-level outline of the steps required to implement a QZ at UP crossings.

8.3.1 Pre-diagnostic Call

The Public Authority will coordinate an initial conference call to include any other authorities with jurisdiction over the roadway, the FRA, Union Pacific, any other railroads that own tracks in the proposed QZ crossings, and any utilities that may be affected. The purpose of the call is to review the Public Authority's concept plans and to schedule the Field Diagnostic, per Section 2.2. The amount of time planned for the Field Diagnostic should include a kick-off meeting, a minimum of 30 minutes at each crossing (additional time for complex crossings) and a wrap-up meeting at the end of each day.

8.3.2 Field Diagnostic

The Public Authority will coordinate a Field Diagnostic comprised of the same stakeholders as were included in the pre-diagnostic call. At a minimum representatives from the Public Authority, FRA and railroad(s) must be present. A QZ diagnostic includes the same process as described in **Section 2.2** of this document and incorporates the additional criteria outlined in the Rule to establish a QZ.

Introduction to this Manual

Process Summary for Public Projects

Active Grade Crossing Warning Systems including Preemption Requirements

Grade Crossings

Grade Separation Projects

Sidewalks and Pathways

Parallel Corridor and Other Projects

Quiet Zones (QZ)

Bridge Painting, Railroad Property Beautification, and Maintenance

Engineering Submittal Requirements and Review Schedule

Payment of UP's Cost, Expenses and Insurance

Agreements and Rights of Entry

Railroad Flagging/Protection for Activities On/Near Railroad Property

Construction Monitoring Requirements

Utility Locates, Crossings, and Protection

Public Safety Initiatives

Additional Resources

8.4 QZ Designation

The following is a summary of some of the designations that can be used to establish a QZ.

8.4.1 Public Authority Designation

This designation can be found under Section 222.39(a) of the Quiet Zone Rule and does not require formal approval by the FRA. It is the opinion of UP that the public authority should make every attempt to establish the proposed QZ under section 222.39(a)(1) by implementing Supplemental Safety Measures (SSMs) at every crossing.

Supplemental Safety Measures may include the following.

- Permanent crossing closures
- Four-quadrant gate systems
- Medians or channelization devices on both approaches to the crossing
- One-way streets with gates

Note that intersecting streets, commercial driveways or alleys within 60 feet of the gate arm in down position may impact whether a median or channelization devices qualify as SSMs. Whenever possible, these intersections should be closed or moved to reduce the risk of motorists circumventing the safety measures to go around the gates.

8.4.2 Public Authority Application

The Public Authority may apply to the FRA for approval of a QZ that does not fall within the criteria for a Public Authority Designation described in the Rule under section 222.39(a). Under this designation one or more safety measures must be implemented that can include alternative safety measures (ASMs), or a combination of ASMs and SSMs. Criteria for this designation can be found under section 222.39(b) of the Quiet Zone Rule.

ASMs are safety improvements that do not fully comply with the requirements for an SSM. These safety improvements must be reviewed by the FRA Associate Administrator who has final approval authority for the QZ.

ASMs can include the following.

- Modified SSMs (e.g., medians less than 60 feet in length, three-quadrant gates)
- Credit for pre-existing modified SSMs
- Engineered ASMs (i.e., geometric improvements)
- Non-engineering ASMs (e.g., programmed enforcement, photo enforcement, public education, and awareness)

UP interprets the Train Horn Rule, as a guideline of minimum safety measures to be implemented at QZs. In the interest of safety, each crossing to be considered for a QZ should be evaluated individually rather than basing the selection of crossings to achieve an averaged risk below the Nationwide Significant Risk Threshold or the Risk Index With Horns.

Introduction to this Manual

Process Summary for Public Projects

Active Grade Crossing Warning Systems including Preemption Requirements

Grade Crossings

Grade Separation Projects

Sidewalks and Pathways

Parallel Corridor and Other Projects

Quiet Zones (QZ)

Bridge Painting, Railroad Property Beautification, and Maintenance

Engineering Submittal Requirements and Review Schedule

Payment of UP's Cost, Expenses and Insurance

Agreements and Rights of Entry

Railroad Flagging/Protection for Activities On/Near Railroad Property

Construction Monitoring Requirements

Utility Locates, Crossings, and Protection

Public Safety Initiatives

Additional Resources

8.5 Notices Required to Establish a QZ

At this point in the process, the diagnostic has been completed, concept plans prepared, and a QZ designation selected. The following notices must be provided from the Public Authority by certified mail. Please note that the stakeholder comment periods start from the date of the postage stamp.

It is critical for the Public Authority to carefully review section 222.43 of the Quiet Zone Rule and follow each step in detail. Failure to comply with the specific requirements for each of the notices will result in rejection due to deficiencies and could add significant delays and costs to the project.

8.5.1 Notice of Intent (NOI)

This is the first notice required to officially start the regulatory process to establish a QZ. It must be sent by certified mail to:

- all railroads operating over the public crossings within the QZ,
- the State agency responsible for highway and road safety, and
- the State agency responsible for Grade Crossing safety.

Although not specified in the Quiet Zone Rule, it is recommended to provide a courtesy copy of the notice to the local FRA contact.

A period of 60 days is allowed for comments to be returned to the public authority from the designated stakeholders. Section 222.43(b) of the Quiet Zone Rule specifies all contents required to be submitted in the NOI.

8.5.2 Notice of Establishment (NOE)

The NOE is the final stage of a QZ project. It is filed once all of the safety improvement project work is complete and the QZ is ready for implementation. The NOE must be sent by certified mail to:

- all railroads operating over the public grade crossings within the QZ,
- the highway or traffic control or law enforcement authority having jurisdiction over vehicular traffic at grade crossings within the QZ,
- the landowners having control over any private grade crossings within the QZ,
- the State agency responsible for highway and road safety,
- the State agency responsible for grade crossing safety, and
- the FRA Associate Administrator.

The NOE must include the date upon which the QZ will be established. This date can be no earlier than 21 days after the date on the postage stamp.

Upon receipt of the NOE, UP performs a review of the information provided to verify all requirements specified under section 222.43(d) of the Rule have been met. Any discrepancies will result in rejection of the NOE. If this happens, the Public Authority must resolve the discrepancies and resubmit the NOE with a new date of establishment.

Additionally, a pre-implementation inspection will be scheduled for attendance by representatives from the Public Authority, FRA, and Railroad(s). The purpose of the inspection is to verify all safety improvements, signs, and pavement markings have been implemented in accordance with the Diagnostic Team recommendations and the Quiet Zone Rule.

UP requests 60 days advance notice of the planned QZ establishment. This communication can be made by email or phone in advance of the official NOE mailing. This allows sufficient time to schedule the pre-implementation inspection, address any discrepancies identified and perform preparation required by the Railroad to cease routine sounding of the train horn.

- Introduction to this Manual
- Process Summary for Public Projects
- Active Grade Crossing Warning Systems including Preemption Requirements
- Grade Crossings
- Grade Separation Projects
- Sidewalks and Pathways
- Parallel Corridor and Other Projects
- Quiet Zones (QZ)**
- Bridge Painting, Railroad Property Beautification, and Maintenance
- Engineering Submittal Requirements and Review Schedule
- Payment of UP's Cost, Expenses and Insurance
- Agreements and Rights of Entry
- Railroad Flagging/Protection for Activities On/Near Railroad Property
- Construction Monitoring Requirements
- Utility Locates, Crossings, and Protection
- Public Safety Initiatives
- Additional Resources

8.6 General Costs of Safety Measures

QZs not only have the potential to create a risk but can also be a cost burden to taxpayers. The Public Authority is responsible for the costs associated with project management, safety measure design, construction, and maintenance and replacement of existing Active Grade Crossing Warning Systems and their components. These costs also include Wayside Horn Systems used either within a QZ or as a one-for-one replacement for the train horn.

In addition to the Reimbursement Agreement required to fund the QZ establishment process, additional agreements may be required for any construction and maintenance work performed by the Railroad. UP will need guaranteed reimbursement for all actual costs associated with the installation and maintenance of the Railroad improvements.

Estimated costs for Railroad improvements for typical QZ safety measures are as follows.

Table 8.1 QZ Safety Measure Estimated Costs

Four-quadrant gate systems:	\$300,000 to \$500,000
Active Grade Crossing Warning Systems (includes flashing lights and gates, constant warning time detection, power out indicator, and cabin):	\$185,000 to \$400,000
Interconnection for existing Active Grade Crossing Warning System with constant warning time:	\$50,000 to \$130,000
Annual maintenance:	\$4,000 to \$20,000

These costs are exclusive of engineering, design, construction management, inspection, travel, and testing.

8.7 Contact Information

To ensure timely response, please forward all QZ notifications by certified mail to the address below.

Union Pacific Railroad
 Engineering-Public Projects
 Attn: Quiet Zone Establishment
 1400 Douglas Street, MS 910
 Omaha, NE 68179-0910

8.8 Union Pacific Project Agreements

An agreement will be required to reimburse the Railroad for all costs associated with a QZ project. Estimated costs for the agreement are based on several factors including the complexity of the project.

See [Section 12.1.1 Reimbursement Agreement](#) for more information.

Introduction to this Manual

Process Summary for Public Projects

Active Grade Crossing Warning Systems including Preemption Requirements

Grade Crossings

Grade Separation Projects

Sidewalks and Pathways

Parallel Corridor and Other Projects

Quiet Zones (QZ)

Bridge Painting, Railroad Property Beautification, and Maintenance

Engineering Submittal Requirements and Review Schedule

Payment of UP's Cost, Expenses and Insurance

Agreements and Rights of Entry

Railroad Flagging/Protection for Activities On/Near Railroad Property

Construction Monitoring Requirements

Utility Locates, Crossings, and Protection

Public Safety Initiatives

Additional Resources



Section 9 Bridge Painting, Railroad Property Beautification, and Maintenance

9.1 Bridge Painting – Anti-Graffiti

We join the community in its frustration with graffiti taggers and the damage they cause. UP special agents often work with local law enforcement to patrol problem areas; however, tagging is challenging to mitigate and, if removed, often returns quickly.

In addition to property damage, taggers are jeopardizing their own safety and, in many instances, the safety of others including UP train crews.

The public is encouraged to report suspicious activity by calling UP's 24/7 Response Management Communications Center at 1 888-UPRR-COP (1-888-877-7267). Trespassers can be cited by UP special agents. Penalties vary by municipality.

In some cases, UP may work with government agencies that have the authority, and funds, to remove graffiti from bridges and structures not owned by UP. In cases involving UP's property, we may consider working with communities who are willing to partner with us in finding a solution to mitigate future tagging. Contact the local **UP Public Affairs Director** to discuss arrangements.

The best way to remove graffiti is painting over it. Requests to have a UP bridge painted must be made online through the **Public Project Contact Center**.

Written requests should include the following:

- City, county, state, contact person, road/highway/waterway name, Railroad mile post, or bridge number (if available)
- Types of paint, proposed color of paint, and method of painting
- State specifications for surface preparation, cleanup, paint, and paint application

If approved, the Applicant will be required to bear all costs associated with the painting project, including any required UP flagging. The Applicant also will have to execute the appropriate UP Right of Entry and Indemnity Agreement for Bridge Painting:

- All states except Texas:
https://www.up.com/cs/groups/public/@uprr/@realestate/documents/up_pdf_nativedocs/pdf_up_reus_bridge-paint-other.pdf
- In Texas:
https://www.up.com/cs/groups/public/@uprr/@realestate/documents/up_pdf_nativedocs/pdf_up_reus_bridge-paint-tx.pdf

9.2 Railroad Property Beautification

In some communities, Railroad Property is highly visible, and agencies or groups may want to perform additional cleanup, paint, mow, and/or install decorative features, streetscaping, fencing, or landscaping. For example, in an urban environment, the agency may want to reseed, place sodding, or perform other landscaping within the UP ROW to improve appearances. The items should not promote trespassing or limit sight distance along the Railroad corridor. UP will not approve a project that allows easy public access to our ROW. These inquiries should be made online through UP's **Public Project Contact Center**.

9.3 Maintenance

Maintenance activities are discussed in the individual sections in the navigation pane to the left.



BUILDING AMERICA®

Introduction to this Manual

Process Summary for Public Projects

Active Grade Crossing Warning Systems including Preemption Requirements

Grade Crossings

Grade Separation Projects

Sidewalks and Pathways

Parallel Corridor and Other Projects

Quiet Zones (QZ)

Bridge Painting, Railroad Property Beautification, and Maintenance

Engineering Submittal Requirements and Review Schedule

Payment of UP's Cost, Expenses and Insurance

Agreements and Rights of Entry

Railroad Flagging/Protection for Activities On/Near Railroad Property

Construction Monitoring Requirements

Utility Locates, Crossings, and Protection

Public Safety Initiatives

Additional Resources



Section 10 Engineering Submittal Requirements and Review Schedule

https://www.up.com/customers/ind-dev/operations/specs/public_projects/index.htm

When making a submittal to UPRR, ensure that the following information is in the email subject line:

“Project type, % Plans, City, State, Street, Milepost, Subdivision, DOT# and Lat/Long”

If this information is not provided, your submittal and UPRR’s response thereto will likely result in delay.

10.1 Plan Set Description

The Exhibit A in an Agreement is a 30% Preliminary Engineering plan set on construction projects. The plan set should show applicable work within Railroad ROW on all other projects (Federal Railroad Signal Program [FSP], re-planking, Railroad capital improvement).

Each Exhibit A should include separate sheets, if applicable, for the following:

- Title sheet with Index of Sheets (not required on re planking projects)
- Project layout sheet (on large construction projects)
- Active Grade Crossing Warning System (if installing or modifying)
- Signing and striping (if not shown with the Active Grade Crossing Warning System)
- Traffic signal layouts and phasing (if Preemption is involved)
- Plan view of conduits, pipes, and culverts under track

- Grade Crossing Panels / Planking layout (if installing or modifying)
- Bridge or Roadway plan and profile
- Rail survey (bridge projects; out to 1,000 feet on both sides of the bridge on overpass projects, and out to 1,500 feet on both sides of the bridge on underpass projects)
- Roadway typical sections (planking and construction projects)
- Rail typical sections (planking and underpass projects)
- Ditch cross sections on 100-foot centers (joint drainage projects)
- Railroad requirements sheets (construction projects)

Any traffic control plan, detour route, and boring logs sheets are usually considered support material and are not part of the Exhibit A plan set.

The checklists in Sections 10.2 through 10.14 are provided for development of these plan sets.

UP will review the Concept, 30%, and Final plans for each public project. See [Section 10.13](#) for more detailed information.

10.2 Checklist for All Plan Sets

All plan sets should include the following:

1. Title sheet included with a project map and Index of Sheets.
2. All sheets numbered and named correctly with Index of Sheets.
3. Project info correctly identified: county, roadway, city, and DOT District, if applicable.
4. Railroad company name, subdivision, mile post, and any DOT numbers identified on the title sheet and in the title blocks of other sheets.



BUILDING AMERICA®

- Introduction to this Manual
- Process Summary for Public Projects
- Active Grade Crossing Warning Systems including Preemption Requirements
- Grade Crossings
- Grade Separation Projects
- Sidewalks and Pathways
- Parallel Corridor and Other Projects
- Quiet Zones (QZ)
- Bridge Painting, Railroad Property Beautification, and Maintenance
- Engineering Submittal Requirements and Review Schedule**
- Payment of UP's Cost, Expenses and Insurance
- Agreements and Rights of Entry
- Railroad Flagging/Protection for Activities On/Near Railroad Property
- Construction Monitoring Requirements
- Utility Locates, Crossings, and Protection
- Public Safety Initiatives
- Additional Resources

5. If there are multiple tracks, each track labeled and identified: Mainline Track, Siding, spur, Yard, wye, etc.
6. Train data shown: number of switching and through movements, including speed for each type of movement.
7. Annual average daily traffic and design speed of roadway traffic shown.
8. General notes:
 - a. All UP work, Contractor work, and work done by other funding source identified correctly.
 - b. Traffic control being provided by the Applicant, not UP.
9. Railroad ROW shown in plans; width of Railroad ROW shown.
10. Existing utilities and utility relocations shown.
11. Existing conditions and proposed conditions shown.
12. Number of days of flagging and number of days of inspection shown (if needed).
13. Drawing should be 1:20 scale whenever possible. Text should be large enough to be clearly legible when the sheet is reduced to 8.5x11-inch size.
14. If plans are drawn in colors, colors are clear, well defined, and easily legible when printed or copied in black and white.
15. Final Exhibit A plans should be sealed, signed, and dated by the licensed Professional Engineer.

10.3 Checklist for Construction Project or Development Adjacent to UP ROW

Plan sets for construction projects or development adjacent to UP ROW should include the following:

1. Title sheet project description that reflects work in Railroad ROW, not the overall plan set.
2. Project plan view layout included if work impacts multiple rail lines or crossings.

3. Fencing shown parallel to track to discourage trespassing (if desirable).
4. Impacts on any existing railroad signals shown.
5. Railroad requirements sheets are included at the end of Exhibit A and are the correct version. Use bridge or non-bridge sheets depending on project scope. Only sheet 1 of 3 may be modified; sheet 1 must be sealed, signed, and dated by the licensed Professional Engineer.
6. Any absolute track Curfew requested from UP shown. (If so, this needs to be requested from UP. This typically applies to overpasses over rail Yards or underpasses.)
7. Any required ROW acquisition shown.
8. Direction of increasing railroad mile post shown.

10.4 Checklist for Projects with Traffic Control Plans

Any construction, safety, re-planking, or railroad capital improvement projects where lane closures are involved or phased construction exists should include a proper traffic control plan for review and development of cost estimates. Plan sets for projects with traffic control plans should include the following:

1. Phased construction showing how Railroad ROW is impacted during all applicable phases.
2. Any lane closures or shifts over At-Grade Crossings that impact crossing surface, railroad signals/Signs, or Preemption shown.
3. Affects on adjacent At-Grade Crossings shown for any project detours.
4. Pedestrian elements properly detailed during all phases.
5. Any temporary traffic signals and Preemption details shown for applicable construction phases.

- Introduction to this Manual
- Process Summary for Public Projects
- Active Grade Crossing Warning Systems including Preemption Requirements
- Grade Crossings
- Grade Separation Projects
- Sidewalks and Pathways
- Parallel Corridor and Other Projects
- Quiet Zones (QZ)
- Bridge Painting, Railroad Property Beautification, and Maintenance
- Engineering Submittal Requirements and Review Schedule**
- Payment of UP's Cost, Expenses and Insurance
- Agreements and Rights of Entry
- Railroad Flagging/Protection for Activities On/Near Railroad Property
- Construction Monitoring Requirements
- Utility Locates, Crossings, and Protection
- Public Safety Initiatives
- Additional Resources

6. All gates, Signs, and cantilevers visible in each phase (driver view not obstructed). Any unnecessary gates deactivated by railroad company when not needed. Any unnecessary signal lights bagged or removed.
7. Total closure of the grade crossing is required for crossing surface (planking) work with traffic detour.

10.5 Checklist for Projects with Overpasses

Plan sets for projects with with Overpass Grade Separations should follow the guidance in the joint UP and BNSF *Guidelines for Railroad Grade Separation Projects*.

10.6 Checklist for Projects with Underpasses

Plan sets for projects with Underpass Grade Separations should follow the guidance in the joint UP and BNSF *Guidelines for Railroad Grade Separation Projects*.

10.7 Checklist for Projects with At-Grade Crossings

Plan sets for projects with At-Grade Crossings should include the following:

1. Design matches field notes from diagnostic inspection.
2. Design incorporates measure to mitigate findings from crash reports.
3. Preemption shown, if any. Are there any adjacent intersections that require Preemption or does project include a traffic signal with Preemption? The MUTCD, Section 4C.10, Warrant 9 should be reviewed as possible justification for the traffic signal. As an alternative, a four-way stop or a two-way stop (stop signs on Roadway parallel to rail line) may be used to assist in moving traffic

- over an At-Grade Crossing.
4. Appropriate signing shown. Diagnostic Team will determine applicable signage to use. See the MUTCD Chapter 8 for requirements for the following:
 - a. Do Not Stop on Tracks (R8-8) Signs on any approaches over At-Grade Crossing heading toward an adjacent intersection where vehicles may stop.
 - b. Stop (R1-1) or Yield (R1-2) Sign at a Passive Grade Crossing; Stop Ahead (W3-1), and Yield Ahead (W3-2) Signs may also be required (see the MUTCD, Section 2C.36).
 - c. Crossbuck (R15-1) Signs on right side of Roadway; a second on left may also be present.
 - d. Number of Tracks (R15-2P) Sign, if more than one track.
 - e. ENS on all approaches (I-13, not R15-4). Minimum two per crossing, one for each approach.
 - f. Low Ground Clearance Grade Crossing Signs (W10-5; W10-5p) if if the Diagnostic Team determines these signs are warranted.
 - g. Grade Crossing Advance Warning Signs (W10-1; W10-2; W10-3; W10-4) on all approaches and parallel roads within 100 feet of the highway intersection; if parallel road is within 100 feet of crossing, install W10-1 Sign on opposite side of Roadway from tracks.
 - h. Advance warning signs may be supplemented with No Gates or Lights (W10-13P) Sign at Passive Grade Crossings.
5. Sidewalks and shared-use Pathways shown:
 - a. Determine if pedestrian gates are warranted, regardless bells must be present on Active Grade Crossing Warning Systems.
 - b. Crossbuck Signs on both sides of Roadway for both approaches.
 - c. Sidewalks should cross perpendicular to rail. Sidewalks should not stop at Railroad ROW line.

- Introduction to this Manual
- Process Summary for Public Projects
- Active Grade Crossing Warning Systems including Preemption Requirements
- Grade Crossings
- Grade Separation Projects
- Sidewalks and Pathways
- Parallel Corridor and Other Projects
- Quiet Zones (QZ)
- Bridge Painting, Railroad Property Beautification, and Maintenance
- Engineering Submittal Requirements and Review Schedule**
- Payment of UP's Cost, Expenses and Insurance
- Agreements and Rights of Entry
- Railroad Flagging/Protection for Activities On/Near Railroad Property
- Construction Monitoring Requirements
- Utility Locates, Crossings, and Protection
- Public Safety Initiatives
- Additional Resources

- d. Railroad masts adjacent to Sidewalks include backlights (depending upon each State).
- e. ADA ramps and proper crosswalks shown at adjacent traffic signals with pedestrian signals.
- 6. Crossing shown has been evaluated for truck traffic:
 - a. Turning radii at adjacent intersections.
 - b. Turning vehicles will not hit gates, Cantilevered Signal Structure or curbs.
- 7. Flatten profile crossings evaluated and mitigated.
- 8. Curbs or islands shown should not be closer than 10 feet from center of rail.
- 9. Medians shown:
 - a. Needed for island gates.
 - b. Protected with painted curb or object marker so they are not hit at night.
 - c. 10-foot minimum width (back of curb to back of curb) preferred.
 - d. Edge of island is parallel to rail, not rounded
- 10. Any culverts shown under Roadway need to be adjusted for Roadway widening.
- 11. Approaches shown: Identify and mitigate any sight distance concerns on either approach such as curved approaches. A "Train When Flashing" (W10-4B) side-mounted or overhead device may be used. An alternate method such as a Cantilevered Signal Structure may be used.
- 12. Super elevation shown on track accounted for on Roadway design.
- 13. Dimensions along the track to component items should be labeled. (point of switch, Yard Limits, Crossover, Multiple Main Tracks, Track Center Spacing, T/R)

- 14. Any track shown being abandoned should be removed along with crossing surface panels and replaced with same material as adjacent pavement.
- 15. A "Tracks Out of Service" (R8-9) Sign is shown with bagged railroad signals in lieu of the Crossbuck Sign (R15-1) for tracks that are temporarily placed out of service.
- 16. Active Grade Crossing Warning Systems and Passive Warning Devices shown should be relocated by UP if an existing track is removed at a multiple track crossing.
- 17. Striping (Pavement Marking) shown is correct:
 - a. Stop bars 8 feet from gate tip of railroad signal post or 15 feet from Near Rail for Passive Grade Crossings; may be located further back based on site evaluation.
 - b. Distance to nearest railroad crossing this grouping of markings is placed (RxR) solid line varies based on approach speed (MUTCD, Table 2C-4, Condition B, Deceleration to 0 mph) shown below:
 - c. 50 feet from Railroad Crossing solid line to Railroad crossing solid line. (RxR)

Figure 10.1 Table 2C-4 Deceleration to 0mph

Solid Line Placement for Railroad Crossings	
Approach Speed (mph)	Distance from Centerline of Track
20	100
25	100
30	100
35	100
40	125
45	175
50	250
55	325
60	400
65	475
70	550
75	650

- Introduction to this Manual
- Process Summary for Public Projects
- Active Grade Crossing Warning Systems including Preemption Requirements
- Grade Crossings
- Grade Separation Projects
- Sidewalks and Pathways
- Parallel Corridor and Other Projects
- Quiet Zones (QZ)
- Bridge Painting, Railroad Property Beautification, and Maintenance
- Engineering Submittal Requirements and Review Schedule**
- Payment of UP's Cost, Expenses and Insurance
- Agreements and Rights of Entry
- Railroad Flagging/Protection for Activities On/Near Railroad Property
- Construction Monitoring Requirements
- Utility Locates, Crossings, and Protection
- Public Safety Initiatives
- Additional Resources

- d. Solid 8-inch white line separates multiple approach lanes and extends 10 feet from back railroad crossing solid line.
 - e. Grade Crossing Advanced Warning Sign (W10-1) adjacent to railroad crossing pavement markings.
 - f. Double yellow line extends back a minimum of 100 feet from nearest rail on two-way left turn lane; area should be hashed out. UP prefers installing a raised non-mountable median.
 - g. Pavement markings are required where speed is 40 mph or greater and at all active crossings on all approach lanes; and/or upon recommendation of the Diagnostic Team.
18. Sign sizes shown correctly per MUTCD Table 8B-1.

10.8 Checklist for Projects with Active Grade Crossing Warning Systems

Plan sets for projects with Active Grade Crossing Warning Systems should include the following:

1. Gates shown perpendicular to the Roadway and not parallel to tracks (i.e., skewed crossings). The Diagnostic Team will determine location and configuration during the Diagnostic Team meeting.
2. Gates, cantilevers, and striping have correct distances shown. The information below is for reference only; the final design and placement of Active Grade Crossing Warning System is determined by the Diagnostic Team at the request of the Applicant:
 - a. 12 feet minimum, 15 feet typical from centerline of railroad signal mast to centerline of nearest track; for skewed crossing, tip of gate must be a minimum of 12 feet from centerline of track. (This offset will vary depending on the crossing angle to the track centerline; i.e., not 90 degrees)
 - b. Minimum 5 feet, 3 inches from center of gate mast to

- edge of curb; or 6 feet from center of gate mast to edge of pavement when Shoulder is present; or 9 feet, 3 inches from edge of pavement if no Shoulder is present. UP recommends additional horizontal clearance, if available.
 - c. Minimum 4 feet from center of gate to center of cantilever, although preference 6 feet to better protect the gate.
 - d. Minimum 6 feet from edge of Sidewalk to center of gate.
3. Any cabin relocations or installations identified. Correct dimensions are shown:
 - a. 30 feet from edge of cabin to edge of pavement or curb.
 - b. 25 feet from edge of cabin to Near Rail.
 - c. Cabin location should not a sight distance issue for vehicles.
NOTE: Cabin location is subject to change by the UP signal.
 4. Correct use of backlights and side lights shown. Any side streets within 100 feet of rail would require side lights. Backlights are required on all two-way non-divided Roadways.
 5. Gate lengths shown are sufficient (gate is measured from the center of post to tip, not longer than 32 feet.) Gates may cover up to two lanes.
 6. Generally, a Median is shown for multiple approach lanes. Median with flasher/gate is typically a lower cost option than a cantilever. (Median width needs to be wide enough for additional gate counter-weight.) The median nose should be squared, not rounded, with a non-mountable 6-inch minimum curb. The location should be 10 feet from the track centerline.
 7. One pair of flashers shown for each approach lane.
 8. UP forces will remove, supply, and install gates, cantilevers, mast flashers, and cross bucks.
 9. Typically front lights are not needed on both a cantilever and a gate if one is in front of the other; the same applies to back lights.
 10. Note included above licensed Professional Engineer's seal: "The Railroad signal circuits and final design location were not designed by the undersigned engineer."



- Introduction to this Manual
- Process Summary for Public Projects
- Active Grade Crossing Warning Systems including Preemption Requirements
- Grade Crossings
- Grade Separation Projects
- Sidewalks and Pathways
- Parallel Corridor and Other Projects
- Quiet Zones (QZ)
- Bridge Painting, Railroad Property Beautification, and Maintenance
- Engineering Submittal Requirements and Review Schedule**
- Payment of UP's Cost, Expenses and Insurance
- Agreements and Rights of Entry
- Railroad Flagging/Protection for Activities On/Near Railroad Property
- Construction Monitoring Requirements
- Utility Locates, Crossings, and Protection
- Public Safety Initiatives
- Additional Resources

11. If signals are being removed, ownership of signals identified.
12. General notes describing the type of railroad circuitry (constant warning, etc.).
13. Clearance time shown correctly for active crossings with skew or multiple tracks.

10.9 Checklist for Interconnected Crossing Projects with Traffic Signal Preemption

Projects with traffic signal Preemption should include the following:

1. Preemption Calculations (including equipment response time, minimum green time, separation time, yellow time, red time, design vehicle, etc.)
2. UPRR Preemption Request Form.
3. Traffic Signal Plans that include:
 - Location of all traffic signal equipment
 - RR Signal Interconnect cable type and specified location between the traffic signal cabin and RR signal house
 - Traffic Signal Controller type, software, and RR interface panel
 - Battery backup system
 - Phasing diagram for normal operation shown
 - Phasing diagram for Preemption operation including transition operations, track clearance, limited service sequences. Also include what Railroad relay information drives each sequence.
 - Railroad Traffic control devices, striping, and signage on background layer
4. Correct timing identified (equipment response time,

- Advance Preemption Time, clearance time, minimum time, and buffer time). Any traffic signal timings shown match timings in design Preemption form.
5. Keep in mind the American Railway Engineering and Maintenance-of-Way Association (AREMA) Manual (*Communications and Signals Manual of Recommended Practices, Volume 1, Section 3, Highway-Rail Grade Crossing Warning Systems*) states that the minimum clearance time is 20 seconds and the maximum allowed Preemption time is 50 seconds.
 6. Conduits and traffic signal cable identified between traffic signal cabinet and Railroad cabin, including who provides and installs materials. Traffic signal cable shown should be a minimum 8 conductor cable.
 7. Protected left turn provided for traffic on track clearance phase (if there is conflicting traffic approaching traffic signal from opposite side of intersection).
 8. Traffic signal poles shown should not block the Active Grade Crossing Warning System.

10.10 Checklist for Projects with Railroad Crossing Surface / Planking Only

Plan sets for projects with Railroad crossing surface / planking only should include the following:

1. Crossing surface identified by material (e.g., concrete, composite, asphalt, timber) and length to be removed and installed. Installed crossing surface will extend at least 3 feet beyond edge of travel lane or Sidewalk. See UP Standard Drawing 0304J, for example.
2. Crossing surface installations shown in 8-foot sections along rail line (NOTE: Some locations may require use of 9-foot or other size panels.).

- Introduction to this Manual
- Process Summary for Public Projects
- Active Grade Crossing Warning Systems including Preemption Requirements
- Grade Crossings
- Grade Separation Projects
- Sidewalks and Pathways
- Parallel Corridor and Other Projects
- Quiet Zones (QZ)
- Bridge Painting, Railroad Property Beautification, and Maintenance
- Engineering Submittal Requirements and Review Schedule**
- Payment of UP's Cost, Expenses and Insurance
- Agreements and Rights of Entry
- Railroad Flagging/Protection for Activities On/Near Railroad Property
- Construction Monitoring Requirements
- Utility Locates, Crossings, and Protection
- Public Safety Initiatives
- Additional Resources

3. Identification of subgrade material installed by the Applicant; existing and new subballast, Ballast, ties, rail, and planking surface removed or installed by UP; and final grading provided by the Applicant.
4. If crossing surface panels are being removed, ownership of panels identified, including any salvage value.
5. Confirmation of full width Roadway closure.

10.11 Checklist for Projects with Crossing Closures

Plan sets for projects with crossing closures should include the following:

1. Details of how crossing will be blocked from the traveling public (e.g., curb and gutter to match existing, Type 3 barricade, turnaround). Embankment shown should be filled to match existing terrain or ditch to discourage drivers from trying to use crossing.
2. Details of Railroad work (e.g., removal of the Active Grade Crossing Warning System and crossing surface panels, passive signing, Roadway on Railroad ROW, restoring ditch).
3. Details of adjacent Roadway improvements (if required):
 - a. Installation of proper Signs to mark closure (if needed);
 - b. No Outlet (W14-2).
 - c. Dead End (W14-1).
 - d. Type 3 barricades.
 - e. Two-Direction Large Arrow Sign (W1-7 or W1-7T).

10.12 Checklist for Projects with Culverts, Drainage Pipes, or Conduits

Plan sets for projects with culverts, drainage pipes, or conduits should include the following:

1. Any roadway related drainage or conduit features within UP Property will require a license agreement from UP. Preemption cables shall be Copper E-80 and are included in the Crossing Agreement. Drainage culverts should be Class V Concrete or encased across the Railroad ROW and out to a distance of 30 feet from Track Centerline.
2. Safety end treatments (SETs) included on culverts.
3. Any conduits (electrical or drainage) should be rigid metal conduits.
4. Conduits (electrical or drainage) installed at least 5 feet below Top of Rail.
5. Boring pits located at least 30 feet from Track Center.
6. Wet boring is not permitted.
7. Corrugated metal pipe, precast pipe, or precast box, which are preferred over cast-in-place construction to minimize impacts on Railroad operations.
8. Any open-cut construction shown must be approved by the Railroad up front and shall not impact Railroad operations.
9. Minimum concrete cover (with steel reinforcement) shown on pipe shall be 2 inches.
10. Dimensions on Exhibit A match pipeline/wireline forms (MUST meet this requirement, or will be denied).
11. Top of pipe at least 5 feet below top of tie and 5 feet below bottom of ditch. Designer should review the UP Drainage Criteria found in **Appendix K**.

- Introduction to this Manual
- Process Summary for Public Projects
- Active Grade Crossing Warning Systems including Preemption Requirements
- Grade Crossings
- Grade Separation Projects
- Sidewalks and Pathways
- Parallel Corridor and Other Projects
- Quiet Zones (QZ)
- Bridge Painting, Railroad Property Beautification, and Maintenance
- Engineering Submittal Requirements and Review Schedule**
- Payment of UP's Cost, Expenses and Insurance
- Agreements and Rights of Entry
- Railroad Flagging/Protection for Activities On/Near Railroad Property
- Construction Monitoring Requirements
- Utility Locates, Crossings, and Protection
- Public Safety Initiatives
- Additional Resources

10.13 Review Submittals and Schedules

Following its own internal plan set review, the Applicant, or its representative, shall submit, at a minimum, all applicable items as defined in **Table 10.13.1 Public Project Submittals and UP Review Times** to the PP-EC through the UP's **Public Project Contact Center** after project has been initiated.

When making a submittal to UPRR, ensure that the following information is in the email subject line:

“Project type, % Plans, City, State, Street, Milepost, Subdivision, DOT# and Lat/Long”

If this information is not provided, your submittal and UPRR's response thereto will likely result in delay.

The Railroad will review and return as approved, approved with exceptions, not approved – reply to comments, rejected, pending, information, or no comment as shown in **Appendix B – UPRR Contact Center Inquiry Submission**.

The Engineer-of-Record's review comment responses must be submitted to the Railroad along with the submittal. See **Appendix C – Design Review Comment Tracking Spreadsheet**.

Each UP review and resubmittal should expect an additional review time starting over. (Concept Review may take multiple reviews until approved)

Roadway Grade Crossing examples are provided in **Appendix F** and **Appendix G**.

- A. The Concept Layout submittal shall, at a minimum, include the following:
 1. Plan and Profiles
 2. Crossing Detail with dimensions of lanes, type of curb, medians, sidewalk, ROW, track centers, warning devices, other features.
 3. Preliminary phasing plan.
 4. Photo log with pictures of the proposed project location. Site pictures shall be in all controlling directions, including, but not limited to, north, east, south, and west. The plan view should show a reference location and direction for each picture.
- B. The 30% Plans submittal shall, at a minimum, include the following:
 1. Applicant response to Railroad review comments on the Concept Layout submittal. The 30% Plans submittal shall reflect Concept Layout review comments.
 2. Design Plans showing a Plan and Profile View, Typical Sections, Crossing Details, Construction Notes, and The 30% Plans shall also indicate roadway design criteria and construction methods.
 3. Project Specifications and/or Special Provisions, including Railroad coordination requirements.
 4. Drainage Report, if required.
 5. Shoofly Design. If roadway needs a temporary crossing, then a plan shall show the location of the Shoofly and indicate the roadway approach and Traffic Control Devices.
 6. Construction Phasing Plans. Construction Phasing Plans must show all required phasing, roadway detours, construction procedures, any temporary shoring layout, controlling dimensions, and elevations.

- Introduction to this Manual
- Process Summary for Public Projects
- Active Grade Crossing Warning Systems including Preemption Requirements
- Grade Crossings
- Grade Separation Projects
- Sidewalks and Pathways
- Parallel Corridor and Other Projects
- Quiet Zones (QZ)
- Bridge Painting, Railroad Property Beautification, and Maintenance
- Engineering Submittal Requirements and Review Schedule**
- Payment of UP's Cost, Expenses and Insurance
- Agreements and Rights of Entry
- Railroad Flagging/Protection for Activities On/Near Railroad Property
- Construction Monitoring Requirements
- Utility Locates, Crossings, and Protection
- Public Safety Initiatives
- Additional Resources

C. The Final Plans submittal shall, at a minimum, include the following:

1. Applicant response to Railroad review comments on the 30% Plans submittal. The Final Plans submittal shall reflect all previous review comments.
2. Design Plans showing a plan and profile view, typical sections, crossing details, construction notes, detailed elevations, removals, signing and pavement marking, and cross sections. The Final Plans shall also indicate roadway design criteria and construction methods.
3. Project Specifications and/or Special Provisions, including Railroad coordination requirements.
4. Drainage Report, as required.

5. Shoofly Design. If roadway needs a temporary crossing, then a plan shall show the location of the Shoofly and indicate the roadway approach and Traffic Control Devices.
6. Construction Phasing Plans. Construction phasing plans must show all required phasing, detours, construction procedures, controlling dimensions, and elevations.
7. Special Conditions should be included and follow the current version of the Special Provisions found in **Appendix M**.

Following review of the Final Plans and resolution of any outstanding issues, the Railroad local representative may issue a letter of project acceptance.

Table 10.1 Public Project Highway-Rail Grade Crossing Submittals and UP Review Times

Phase		Type of Submittal	Submittal Format*	Railroad Review Time**
Design	A	Concept Layout (Plans and Site Pictures)	PDF only	4 – 6 weeks
	B	30% Plans (Applicant concept comment response, design plans, project Specifications list, drainage report and plan, detailed Highway-Rail Grade Crossing layout with warning devices, pavement markings, construction phasing detour plan)	PDF only	4 – 6 weeks
	C	Final Plans (Applicant comment response, design plans, project Specifications list, drainage report and plan, detailed Highway-Rail Grade Crossing layout with warning devices, pavement markings, construction phasing detour plan)	PDF only	4 – 6 weeks
Construction		Including, but not limited to, the following: <ul style="list-style-type: none"> • Roadway Typical Sections • Removals • Crossing Detail Sheets • Signing and Pavement Markings • Construction Phasing Plans 	PDF only	4 – 6 weeks

*The following submittal format is required:
PDF - The PDF shall be formatted to reproduce legibly on 11" x 17" sheets.

**Submittals that do not follow the schedule outlined in this table or are partial, incomplete, or inadequate may require greater review time.

See the UP and BNSF [Guidelines for Railroad Grade Separation Projects](#), Table 3-2, for more complex foundation elements (retaining wall, footings, etc.).



- Introduction to this Manual
- Process Summary for Public Projects
- Active Grade Crossing Warning Systems including Preemption Requirements
- Grade Crossings
- Grade Separation Projects
- Sidewalks and Pathways
- Parallel Corridor and Other Projects
- Quiet Zones (QZ)
- Bridge Painting, Railroad Property Beautification, and Maintenance
- Engineering Submittal Requirements and Review Schedule**
- Payment of UP's Cost, Expenses and Insurance
- Agreements and Rights of Entry
- Railroad Flagging/Protection for Activities On/Near Railroad Property
- Construction Monitoring Requirements
- Utility Locates, Crossings, and Protection
- Public Safety Initiatives
- Additional Resources

Each UP review and resubmittal should expect an additional review time starting over. (i.e. Concept Review may take multiple reviews until approved)

10.14 Requests for Exception Variance

- A. Requests for exception to Railroad requirements shall be submitted to the Railroad PP-EC for review. The Railroad may approve or reject any request for exception. Approval from the Railroad is required prior to proceeding with an exception.
- B. Provide written engineering justification for proposed requests for exception
- C. Variance requests require significant UP review and will cause delay to the project.
- D. The request should succinctly describe the geometric, structural and other constraints which justify the request. Cost alone should not be the determining factor.

Introduction to this Manual

Process Summary for Public Projects

Active Grade Crossing Warning Systems including Preemption Requirements

Grade Crossings

Grade Separation Projects

Sidewalks and Pathways

Parallel Corridor and Other Projects

Quiet Zones (QZ)

Bridge Painting, Railroad Property Beautification, and Maintenance

Engineering Submittal Requirements and Review Schedule

Payment of UP's Cost, Expenses and Insurance

Agreements and Rights of Entry

Railroad Flagging/Protection for Activities On/Near Railroad Property

Construction Monitoring Requirements

Utility Locates, Crossings, and Protection

Public Safety Initiatives

Additional Resources



Section 11 Payment of UP's Cost, Expenses, and Insurance

All UP costs and expenses related to a Public Project must be reimbursed by the Applicant or agency. This includes management, Preliminary Engineering, construction observation and inspection, agreement preparations, design reviews, and maintenance. All ROEs, License Agreements, and C&M Agreements, etc., require specific insurance coverage.

11.1 UP's Design Review Cost Reimbursement

The management and design review costs for typical and complex Public Projects during the design and construction phases are shown in **Table 11-1**.

11.2 UP's Railroad Improvement Costs

All railroad improvement costs must be estimated by UP on a project by project basis. Please allow at least 90 days for all cost estimating requests. Some examples of railroad improvement costs as estimated by UP are as follows:

- Four-quadrant gate systems: \$300,000 to \$500,000
- Typical Active Grade Crossing Warning System (includes flashing lights and gates, Constant Warning Time Detection, power out indicator, and cabin): \$185,000 to \$400,000
- Interconnection: \$50,000 to \$130,000
- Annual maintenance: \$4,000 to \$20,000
- Crossing Surface (Planking): \$2,000 per track foot

These costs are exclusive of engineering, design, construction management, inspection, travel, and testing.

11.3 UP's Flagging Costs

The flagging costs are separate from the other types of engineering, construction, and railroad material costs. On average, flagging services cost \$1,500 per day. Flagging will be invoiced as an 8-hour day minimum, see the online [application for flagging services](#) for actual costs. Applicant will need to contract directly with with a UP approved Flagging contractor, see [Section 13 – Railroad Flagging/Protection](#). Additional information will also be included in the applicant's ROE.

11.4 UP's Real Estate Fees

The fees associated with individual applications cover development of the agreement but do not cover the additional legal review fees that may be required should more complicated agreement negotiations occur. All UP labor and expenses associated with agreements and Right of Entry Permits are the sole responsibility of the Applicant.

11.5 Insurance Requirement for Public Projects

The licensee shall, at its own sole cost and expense, procure the following kinds of insurance and promptly pay, when due, all premiums for that insurance. The following insurance shall be kept in force during the life of the applicable agreement:

- Commercial General Liability Insurance
- Business Automobile Liability Insurance
- Worker's Compensation Insurance
- Railroad Protective Liability Insurance (RPLI; during construction or maintenance only).

The limits of coverage under each of the required insurance policies will be based on the activity and risk involved with the specific project. Specific insurance requirements will be provided to you in the agreement covering your project when it is approved by the Railroad.



BUILDING AMERICA®

Table 11.1 Management and Design Review Costs

PROJECT TYPE	UPRR General Cost Estimates for Project Management/Structure & Design Review								EXAMPLES
	TYPICAL				COMPLEX				
	Prelim Eng	+	C&M/Project	<--Agreement Type	Prelim Eng	+	C&M/Project	<--Agreement Type	
	Design Phase	+	Construction Phase	TOTAL	Design Phase	+	Construction Phase	TOTAL	
Railroad Warning Devices	\$25,000	+	\$30,000	\$55,000	\$50,000	+	\$75,000	\$125,000	Typical – Standard installation of Railroad Warning Devices, no roadway changes Complex – Signal Preemption/ Interconnect, Road reconfiguration, Multiple agencies, Four Quad Gates
Railroad Crossing Surface	\$10,000	+	\$15,000	\$25,000	\$15,000	+	\$15,000	\$30,000	Typical – Standard installation of Railroad track and concrete crossing surface Complex – Regulatory Agency or DOT Order Required
General Maintenance At Grade Crossing Roadway Work	\$5,000	+	\$10,000	\$15,000	\$10,000	+	\$10,000	\$20,000	Typical – General chip and seal, review of roadway work, signing & striping Complex – Regulatory Agency or DOT Order Required
General Maintenance Bridge Roadway Work	\$25,000	+	\$25,000	\$50,000	\$50,000	+	\$50,000	\$100,000	Typical – Barrier Rail & Fence repair/renewal Complex – Deck Reconstruction, Railroad Inner Guardrail, Pier Protection
Grade Separation (RR Under)	\$25,000	+	\$50,000	\$75,000	\$200,000	+	\$200,000	\$400,000	Typical – Spans Railroad ROW (Follows Grade Separation Guidelines) Complex – Crosses a yard, extensive construction phasing required, shoofly, inner
Grade Separation (RR Over)	\$75,000	+	\$125,000	\$200,000	\$450,000	+	\$400,000	\$850,000	Typical – Single lane bike trail tunnel, no track work Complex – Crosses a yard, extensive construction phasing required, shoofly
Levee/Floodwalls	\$50,000	+	\$75,000	\$125,000	\$225,000	+	\$350,000	\$575,000	Typical – Levee maintenance near industrial tracks Complex – New levees and floodwalls affecting mainline tracks, encroaching ROW, yards involved.

NOTES: Amounts do not include costs associated with Railroad's Non-Design-related Labor & Material. The above figures are estimates only. Agency responsible for actual project costs. Amounts above do not include Real Estate Fees (such as license, easement or agreement) or Flagging Costs.



Introduction to this Manual

Process Summary for Public Projects

Active Grade Crossing Warning Systems including Preemption Requirements

Grade Crossings

Grade Separation Projects

Sidewalks and Pathways

Parallel Corridor and Other Projects

Quiet Zones (QZ)

Bridge Painting, Railroad Property Beautification, and Maintenance

Engineering Submittal Requirements and Review Schedule

Payment of UP's Cost, Expenses and Insurance

Agreements and Rights of Entry

Railroad Flagging/Protection for Activities On/Near Railroad Property

Construction Monitoring Requirements

Utility Locates, Crossings, and Protection

Public Safety Initiatives

Additional Resources

11.5.1 Railroad Protective Liability Insurance

Railroad Protective Liability Insurance (RPLI) is for projects under \$10 million that do not exceed 12 months.

When working within Railroad ROW, your company will be required to obtain RPLI for the project.

For RPLI application requests, you may be asked by your insurance carrier to provide train movement information. For security and safety reasons, UP employees no longer supply train information to parties outside the Railroad. The major insurance companies are aware of this. Public information is available on the FRA Office of Safety Analysis' Crossing Inventory Database, if needed.

A Railroad Protective Liability Program is available through the national broker, MARSH. Visit the [MARSH website](#) for an application and contact information.

New Highway-Rail Grade Crossing Agreements require the following:

1. New individual and residential Private Crossings and Encroachments:
 - a. General Public Liability providing \$1 million for each occurrence and general aggregate limit of \$1 million
 - b. Automobile Public Liability providing \$500,000 for each occurrence

2. Commercial and industrial crossings and Encroachments and Contractors' Private Crossings and Encroachments:
 - a. General Public Liability providing \$5 million for each occurrence and general aggregate limit of \$10 million
 - b. Automobile Public Liability providing \$2 million for each occurrence
 - c. Worker's Compensation covering the statutory liability determined by state law
 - d. Railroad Protective Liability providing \$2 million for each occurrence and aggregate limit of \$6 million

Examples of the insurance required for various types of projects are found on the [UP Insurance Requirements website](#).



BUILDING AMERICA®

- Introduction to this Manual
- Process Summary for Public Projects
- Active Grade Crossing Warning Systems including Preemption Requirements
- Grade Crossings
- Grade Separation Projects
- Sidewalks and Pathways
- Parallel Corridor and Other Projects
- Quiet Zones (QZ)
- Bridge Painting, Railroad Property Beautification, and Maintenance
- Engineering Submittal Requirements and Review Schedule
- Payment of UP's Cost, Expenses and Insurance
- Agreements and Rights of Entry**
- Railroad Flagging/Protection for Activities On/Near Railroad Property
- Construction Monitoring Requirements
- Utility Locates, Crossings, and Protection
- Public Safety Initiatives
- Additional Resources



Section 12 Agreements and Rights of Entry

12.1 Agreements

A number of agreements are required between UP and the Applicant for a Public Project. The agreements define the scope of design review and construction work involved, the responsible parties, future maintenance costs and responsibilities, liability stipulations, project costs, safety requirements, construction monitoring, and inspection. Be advised some Public Projects may require more than one type of agreement depending on specific circumstances.

The Applicant should allow sufficient time during the Public Project's design schedule for development and execution of the various agreements.

12.1.1 Reimbursement Agreement

The RA was formerly named the Preliminary Engineering Agreement. In an effort to become more efficient, the UP Public Projects team renamed this agreement the RA because, although it is primarily for engineering reviews, it covers additional reimbursements as well.

- UP requires all new RAs to use the UP Standard Reimbursement Agreement.
- There could be a separate agreement for UP engineering reviews during the construction phase of the project or these items could be included within the same RA. Each Applicant should discuss this during development of the RA.
- The RA will be handled electronically through the PP-EC after it has been verified internally and then executed by all parties.
- No modifications of the UP Standard Reimbursement Agreement will be entertained. A high-level RA workflow is as follows:

1. The Applicant submits an inquiry through UP's **Public Project Contact Center**. See **Appendix B** for the UPRR Contact Center Inquiry Submission steps
2. If approved to continue, the PP-EC contacts the Applicant about details of the project needed to prepare an RA.
3. The RA is drafted for review and execution electronically.
4. Upon electronic execution by the Applicant, the software routes the agreement to the respective UP manager for execution.
5. Once fully executed, all parties included in the workflow will receive a copy of the fully executed RA.

Figure 12-1 Reimbursement Agreement Process

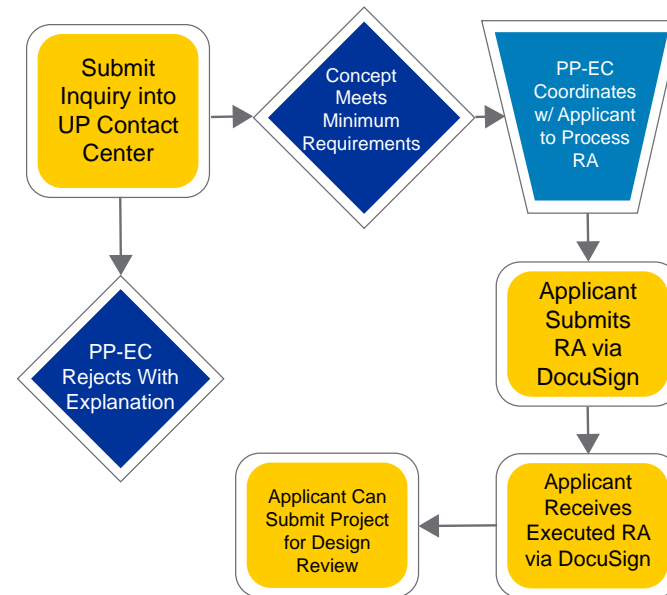

- Introduction to this Manual
- Process Summary for Public Projects
- Active Grade Crossing Warning Systems including Preemption Requirements
- Grade Crossings
- Grade Separation Projects
- Sidewalks and Pathways
- Parallel Corridor and Other Projects
- Quiet Zones (QZ)
- Bridge Painting, Railroad Property Beautification, and Maintenance
- Engineering Submittal Requirements and Review Schedule
- Payment of UP's Cost, Expenses and Insurance
- Agreements and Rights of Entry**
- Railroad Flagging/Protection for Activities On/Near Railroad Property
- Construction Monitoring Requirements
- Utility Locates, Crossings, and Protection
- Public Safety Initiatives
- Additional Resources

12.1.2 Construction and Maintenance Agreement

The C&M Agreement is typically applicable for any new facilities or significant rebuild of existing facilities involving UP ROW. These agreements specifically define the initial construction responsibilities and future maintenance responsibilities for the Applicant and the Railroad. Typical types of C&M Agreements with the Highway-Railroad Grade Crossing are:

- Grade Separation Agreement
- Active Warning System (Signal) Agreement
- Surface (Planking) Agreement
- Interconnection (Signal Preemption) Agreement

12.1.3 Maintenance Consent Letter Agreement

The Maintenance Consent Letter (MCL) is the most common agreement. It pertains to an Applicant's maintenance activities that fall within the Railroad ROW, including the following:

- Mill and overlay of asphalt paving of existing Highway-Rail Grade Crossing approaches. (Plans must include signing and pavement marking plans that meet the MUTCD.) See [Section 4.1](#) for more Planking information and limits of work, etc.)
- Existing Sidewalk repairs
- Existing fence repairs
- Lighting
- Bridge inspection
- Roadway Bridge minor repairs such as barrier rail or fencing replacement, deck seal-coating, deck or pier spall repairs
- Culvert and ditch cleaning
- Replace or maintain Traffic Control Devices

For the MCL process to apply there must be a pre-existing C&M Agreement or Master Agreement in place covering the initial construction of the subject facility.

The MCL process strictly covers maintenance activities and does not apply to modifications to the crossing such as widening of existing Roadways, major changes to the subject facility such as a complete rebuild or to new crossing projects. All maintenance activities must be in strict compliance with the current MUTCD along with any applicable state and local standards. When the Applicant is planning for a maintenance activity near the Railroad, the applicable Railroad portion of the work should not be skipped out of convenience. Roadway traffic control plans should not modify the level of protection at the Grade Crossing.

Temporary Traffic Control within the RR ROW associated with Maintenance work must be reviewed by UP and coordinated early. See Section 4.6 for more information.

To request a MCL Agreement the Applicant should submit an inquiry through UP's [Public Project Contact Center](#). This submittal should include the plans prepared by the Applicant. The MCL Agreement will include instructions for the selected contractor to obtain a ROE as well as instructions to request Railroad flagging protection.

12.1.4 Master Agreement

Master Agreements are for agencies that have a large volume of Public Projects, such as a state DOT. Typically a Master Agreement outlines general boilerplate language to be used in subordinate agreements and is in place to streamline the project agreement process. It does not eliminate the need for project-specific agreements, ROE, or flagging.

12.2 Entry onto UP Right of Way or Property

The Railroad requires all parties accessing its ROW for investigative activities or for the performance of construction work to have a written agreement fully outlining each party's responsibilities. Activities by others with the potential to impact the Railroad's property, operations, and/or personnel without actually entering the Railroad property must also be reviewed and agreements and appropriate arrangements completed, including pre-construction meeting with UP.

- Introduction to this Manual
- Process Summary for Public Projects
- Active Grade Crossing Warning Systems including Preemption Requirements
- Grade Crossings
- Grade Separation Projects
- Sidewalks and Pathways
- Parallel Corridor and Other Projects
- Quiet Zones (QZ)
- Bridge Painting, Railroad Property Beautification, and Maintenance
- Engineering Submittal Requirements and Review Schedule
- Payment of UP's Cost, Expenses and Insurance
- Agreements and Rights of Entry**
- Railroad Flagging/Protection for Activities On/Near Railroad Property
- Construction Monitoring Requirements
- Utility Locates, Crossings, and Protection
- Public Safety Initiatives
- Additional Resources

Any unauthorized entry onto Railroad property could be considered trespassing by federal, state, or local law, and could lead to criminal prosecution.

The process by which an appropriate agreement covering entry and/or the other necessary conditions or requirements can be developed and implemented is typically dependent upon the scope of the activities proposed by the Applicant. Typically all work performed above, below, across, or adjacent to Railroad ROW must have a ROE unless it is covered under the MCL process presented in Section 12.1.3.

12.2.1 ROE – Non-Intrusive

Any need to be on the Railroad’s property to perform investigation or survey without any intrusion will require a Non-Intrusive permit to perform this work. This includes any engineering survey working without the use of vehicle and machinery on the Railroad ROW. There will be the requirement for a Railroad Flagger any time the Applicant is the Railroad ROW, see Section 13. The application for this permit can be found on the UP website at the following location:

https://www.up.com/cs/groups/public/@uprr/@realestate/documents/up_pdf_natedocs/re_nonintrusive_survey_app.pdf

Another form of non-intrusive survey is the use of Unmanned Aircraft Systems (UAS), or drones, flown for commercial or recreational purposes. Drones may not take off from or land on Railroad property unless authorized to do so in writing by a specific agreement with the UP. All UAS flights must adhere to FAA and UP’s UAS Guidelines. See the **UP Safety** page for more information.

12.2.2 ROE – Temporary Use (Intrusive)

Any need to be on the Railroad’s property to perform temporary work that will be intrusive will require a ROE Temporary Use permit to perform this work. Generally this includes any activity that will create, or has the potential to create, a disruption to the Railroad ROW or to Railroad operations. There is an application fee required for these permits along with the requirement for the Applicant to provide proof of insurance. There will be the requirement for a Railroad Flagger any time the Applicant is the Railroad ROW, see Section 13. The normal turn-around time for processing applications is now running between 30-45 days. If you require rush handling there will be an additional fee required. Typical Temporary Use ROE include:

- Surveying that requires vehicle access on the property and/or underground investigation.
- Contractor conducting work on behalf of an Applicant.
- Public Road Authority doing work on the Railroad ROW.
- Seismic and vibrosis surveys
- Soil borings, testing, and well maintenance
- Beautification of the Railroad ROW
- Encroachments on the Railroad ROW.
- Community events on or near the Railroad ROW
- Movie productions
- Other projects involving temporary use of Railroad ROW

Additional information regarding the Temporary Use of the Railroad ROW permit along with the online application can be found on the UP website at the following location:

https://www.up.com/real_estate/tempuse/index.htm



- Introduction to this Manual
- Process Summary for Public Projects
- Active Grade Crossing Warning Systems including Preemption Requirements
- Grade Crossings
- Grade Separation Projects
- Sidewalks and Pathways
- Parallel Corridor and Other Projects
- Quiet Zones (QZ)
- Bridge Painting, Railroad Property Beautification, and Maintenance
- Engineering Submittal Requirements and Review Schedule
- Payment of UP's Cost, Expenses and Insurance
- Agreements and Rights of Entry**
- Railroad Flagging/Protection for Activities On/Near Railroad Property
- Construction Monitoring Requirements
- Utility Locates, Crossings, and Protection
- Public Safety Initiatives
- Additional Resources

12.2.3 Railroad ROW Mapping Requests from UP

UP Real Estate works with a Real Estate Consultant (REC) to manage Applicant requests for the railroad's Valuation Maps. All mapping requests must be submitted to:
Ms. Kendall Giwoyna – UP Map Librarian
kgiwoyn@upcontractor.up.com
 402-501-4941

Please supply the following information; it is required in order for the REC to retrieve your map(s), if available:

1. The project title, DOT #, and UP folder # in the email subject line.
2. A description of what you are requesting and how you will be using the mapping. State the nature of the work you will be performing and the type of survey for which you will be using the maps.
3. City and state (not just county name) of the area being requested.
4. At or between any mile posts you may know.
5. The Railroad subdivision name if you have it. You may locate mile posts and the Railroad subdivision name at <http://fragis.fra.dot.gov/gisfrasafety>.
6. Street names that encompass the area you are requesting.
7. A Google Earth map of the area that includes legible street names. Google Earth is the only acceptable map (not an aerial, an abstract, a tax assessor's map, a Tobin map, or a link of any kind). Please do not place your Google Earth map within the body of the email; include it as an attachment.

Do not include an abstract or tax assessor's information as it does not help in finding the map.

8. The original railroad company name before it was sold, abandoned, retired, etc.
9. Township, range, and section(s), if you know it. This is not applicable for the state of Texas. For Texas, please include the survey name.
10. Your company name, address, city, state, zip code, phone number, and email address.
11. Name of UP contact, if working on this particular project with UP.
12. Name of government agency, if working on project with one (not as a subcontractor).

The REC will send you a snapshot of the area they believe that you are requesting. Please review it for accuracy and send a confirmation email to the REC. The maps you requested will be sent 1 or 2 days after your confirmation email is received. This confirmation must be received within 10 calendar days from the snapshot being sent or the request will be closed.

The REC can send you PDF(s) of the maps you requested using the email address you have provided and/or can make hard copies to send to you at your postal address. If you have a large format printer available, you should be able to print out the PDF(s) yourself rather than having the REC send hard copies to you.

There is a fee for UP to provide Railroad ROW mapping. The invoice will be sent by the billing department automatically. You would then pay by check to the address listed on the invoice. The billing department does not accept credit card payments at this time.

Before the REC can process your request and send you the PDF(s) or your maps, they will need your approval of this fee and a complete business billing address. Please include the recipient if someone other than the Applicant.

- Introduction to this Manual
- Process Summary for Public Projects
- Active Grade Crossing Warning Systems including Preemption Requirements
- Grade Crossings
- Grade Separation Projects
- Sidewalks and Pathways
- Parallel Corridor and Other Projects
- Quiet Zones (QZ)
- Bridge Painting, Railroad Property Beautification, and Maintenance
- Engineering Submittal Requirements and Review Schedule
- Payment of UP's Cost, Expenses and Insurance
- Agreements and Rights of Entry**
- Railroad Flagging/Protection for Activities On/Near Railroad Property
- Construction Monitoring Requirements
- Utility Locates, Crossings, and Protection
- Public Safety Initiatives
- Additional Resources

Once the PDF(s) is sent via email (and/or hard copies mailed), you will be charged the fee, even if you decide you no longer need the maps and want your request canceled. If you cancel prior to the maps being sent, there will be no charge.

Research and/or reproduction costs associated with your request, as well as any express delivery charges, are in the following fees:

- If you are working for federal, city, county, or state governmental agencies on surveys, the cost is \$75.00 for up to seven PDF files (if available). Please state the governmental agency for which you are working. Utility companies are not considered a federal, city, county, or state governmental agency.
- For all other surveys (boundary, individual, etc.), the cost is \$130.00 for up to seven PDF files (if available).
- If you need the UP tax identification number to make your payment, please request it when you send the confirmation email that the correct maps have been sent. The W9 will be sent with your invoice.
- If your requested area covers more than seven maps, there will be an additional fee of \$5.00 per map after the first seven.
- If you are working with UP on this project, please provide the UP representative's name and details of the project you are involved in together. The REC will then contact the representative for the release of the maps. (Just speaking with the UP employee for information is not considered working with the employee.)

- If you are requesting any information regarding deeds, real estate ownership, etc., please contact our main switchboard and you will be directed accordingly. The REC only processes ROW map requests and station map requests. You could also check with your county records office. The maps might be available from them.
- If your request has anything to do with any form of litigation, you must contact our Law Department; the REC cannot release any maps for this purpose.

Shipping is not included in the fees above if hard copies are requested. The additional hard copy fee is \$20.00, which includes printing and shipping.

12.3 Real Estate Purchases

The Railroad has an on-going program to sell non-operating surplus property. This would be Property, as solely determined by the Railroad, which no longer has a Railroad function. Additional details regarding this program can be found on the UP website at the following location:

https://www.up.com/real_estate/purchase/index.htm

Introduction to this Manual

Process Summary for Public Projects

Active Grade Crossing Warning Systems including Preemption Requirements

Grade Crossings

Grade Separation Projects

Sidewalks and Pathways

Parallel Corridor and Other Projects

Quiet Zones (QZ)

Bridge Painting, Railroad Property Beautification, and Maintenance

Engineering Submittal Requirements and Review Schedule

Payment of UP's Cost, Expenses and Insurance

Agreements and Rights of Entry

Railroad Flagging/Protection for Activities On/Near Railroad Property

Construction Monitoring Requirements

Utility Locates, Crossings, and Protection

Public Safety Initiatives

Additional Resources



Section 13 Railroad Flagging/Protection for Activities On/Near Railroad Property

13.1 What is Railroad Flagging/Protection

Railroad flagging is required for all activities that encroach onto Railroad Property. Specifically, where workers or equipment have a potential to foul tracks, 25 feet but could be a greater distance. This also applies to the area above Railroad tracks such as on Roadway Overpass Grade Separations or overhead utility work.

This Railroad Flagger is not the same as providing a Roadway flagger, who directs vehicle traffic on a highway project. The Railroad Flagger communicates with the dispatcher or other Railroad employees. They monitor train operations and, as authorized Railroad representatives, are able to shut down projects for work practices that appear to be unsafe.

Railroad Flaggers are not authorized to regulate train frequency or train speeds, but are provided to verify that the track is cleared for approaching trains. Railroad Flaggers are not inspectors and cannot recommend or approve work practices or product.

The Railroad Flagger providing protection for train movements for a construction crew is restricted by time and location limits given by train dispatchers, and the Flagger may not be able to assist crews outside of those limits.

The Applicant must have a previously approved Real Estate Agreement, such as a Right of Entry Agreement, Roadway Crossing Agreement, or Maintenance Consent Letter Agreement, prior to requesting flagging.

The MCL Agreement will include instructions for the selected contractor to obtain a ROE as well as instructions to request Railroad flagging protection.

Please see the [UP website](#) for more information.

13.2 Flagging Process

UP has established a straightforward process for Railroad Flagging/Protection requests. The steps are as follows:

- Step 1** The Applicant must obtain an executed Real Estate Agreement.
- Step 2** The Applicant's Contractor follows the process outlined in the executed Real Estate Agreement.

Contractor shall be permitted to hire a private contractor to perform flagging or other special protective or safety measures (such private contractor being commonly known in the railroad industry as a contractor-in-charge ("CIC")) in lieu of Railroad providing such services or in concert with Railroad providing such services, subject to prior written approval by Railroad, which approval shall be in Railroad's sole and absolute discretion.

- There are many projects where an UP-Approved Contractor who is certified can perform these protection duties in lieu of a UP-employee Flagger. In this situation, the Applicant would coordinate directly with and reimburse the flagging Contractor. The contact information will be provided by UP during the ROE Agreement process (https://www.up.com/real_estate/third-party-flagging/index.htm).

Union Pacific Railroad Approved List

Rail Pros

Email: UP.info@railpros.com

Phone: 877-315-0513, ext 116

National Railroad Safety Services

Email: UP.request@nrssinc.net

Phone: 877-984-6777

<https://www.nrssinc.net/contacts>



BUILDING AMERICA®

Introduction to this Manual

Process Summary for Public Projects

Active Grade Crossing Warning Systems including Preemption Requirements

Grade Crossings

Grade Separation Projects

Sidewalks and Pathways

Parallel Corridor and Other Projects

Quiet Zones (QZ)

Bridge Painting, Railroad Property Beautification, and Maintenance

Engineering Submittal Requirements and Review Schedule

Payment of UP's Cost, Expenses and Insurance

Agreements and Rights of Entry

Railroad Flagging/Protection for Activities On/Near Railroad Property

Construction Monitoring Requirements

Utility Locates, Crossings, and Protection

Public Safety Initiatives

Additional Resources



Section 14 Construction Monitoring Requirements

14.1 Overview

To promote the safety of the public and Railroad employees, to maintain quality rail service to the Railroad's customers, and to protect its property and assets, the Railroad may require construction monitoring (which is in addition to flagging) of the project. The construction monitoring will be conducted by Railroad employees and by consultant forces as hired by the Railroad, all as a project expense.

14.2 General Guidelines

Construction monitoring includes intermittent or continuous onsite presence of Railroad employees or their designated representative during construction activities, as follows:

- The Applicant will be financially responsible for the cost of construction monitoring. Construction monitoring will be specified, and the estimated cost will be included in the C&M Agreement for the project.
- Construction monitoring is in addition to flagging.
- Construction monitoring includes Railroad review and approval of all plans, plan changes, and required submissions during the construction phase of the project.
- The Applicant is ultimately responsible for the safety of the work site, including property, Contractors, and employees.
- The Railroad, as part of its construction monitoring, will review the work site for activities that could interfere with safe operation of the Railroad. The Railroad is not responsible for monitoring the general work activities under the direction of the Applicant for compliance with safety regulations.
- Any observed unsafe acts or conditions will be reported immediately to the Applicant or Contractor representative.

14.3 Typical Steps for Construction

Union Pacific wants all who work with us to go home safely each day. Safety begins with you!

Typical steps during the construction stage of the project are as follows:

- The Applicant and the UP Public Projects team will execute a Construction and Maintenance (C&M) Agreement or a ROE following UP design approval.
- The Applicant will provide UP authorization to incur and be reimbursed for engineering costs, typically given as part of the project agreement or with a Notice to Proceed. The Railroad may hire an inspector/coordinator consultant (I/C) to coordinate with the designated MPP or PP-EC. The designated Railroad Representative may be a Railroad employee or I/C.
- The work may proceed only upon proper notice to the UP project engineer, per the project agreement.
- A pre-construction meeting must be scheduled and be attended by the Applicant, the Contractor, the Railroad and possibly the I/C.
- The Contractor will be required to produce and maintain a Safety Management Plan which will be periodically reviewed.
- The Railroad representative will attend job safety meetings on a periodic basis and will attend regularly scheduled project meetings.
- The Railroad representative will confirm that the project is constructed per accepted plans and specifications for the portion of the project on Railroad ROW.



BUILDING AMERICA®

- Introduction to this Manual
- Process Summary for Public Projects
- Active Grade Crossing Warning Systems including Preemption Requirements
- Grade Crossings
- Grade Separation Projects
- Sidewalks and Pathways
- Parallel Corridor and Other Projects
- Quiet Zones (QZ)
- Bridge Painting, Railroad Property Beautification, and Maintenance
- Engineering Submittal Requirements and Review Schedule
- Payment of UP's Cost, Expenses and Insurance
- Agreements and Rights of Entry
- Railroad Flagging/Protection for Activities On/Near Railroad Property
- Construction Monitoring Requirements**
- Utility Locates, Crossings, and Protection
- Public Safety Initiatives
- Additional Resources

- The Railroad representative will monitor construction activities to confirm the project on UP ROW meets all UP requirements and accommodates railroad operations, while also immediately reporting to the UP project engineer any material or performance test failures, or suspected deviations from plans, which could negatively impact UP.
- The Railroad representative will be the all-around liaison to the UP Engineering Design and Structures, Operations, Track, Environmental, Signal, and other UP teams, as needed, throughout the construction of the project, and will coordinate work, conduct quality control, and monitor construction.
- The Railroad representative will review all submittals from the Applicant, as required. The I/C will handle comments from reviews by the UP project engineer and UP Structures team and will verify that UP has taken no exception with required submittals prior to applicable work commencing. Note that a third-party review may be needed for complex shoring and adjacent UP asset monitoring.
- Any safety concerns, schedule deviations, material or performance test failures, or suspected changes from agreed upon plans that could negatively impact the Railroad will be immediately reported to the MPP or PP-EC.
- The Railroad representative will assess job site housekeeping and general safety, including use of personal protective equipment (PPE). Issues will be discussed with the Contractor and Applicant, and noncompliance will be elevated to the Railroad.
- The Railroad representative will help coordinate with the assigned Flagger, including scheduling of any requested track outage work or other on-track safety.

Any Railroad employee or the I/C has authority to remove a Contractor's employee from Railroad Property if that employee fails to comply with any safety policy, does not have proper PPE, or otherwise does not comply with instructions regarding work on Railroad Property. Furthermore, any Railroad employee or the I/C has the authority to shut down work on the project if the Contractor works in a manner that is in violation of the Railroad's safety policy or Roadway Worker Protection rules.

The Railroad representative will immediately notify the Flagger and contact the MPP or PP-EC when a project is shut down. All equipment and personnel will be removed from the property until issues causing the shutdown are resolved to the satisfaction of the Railroad and construction inspector.

14.4 Demolition

All demolition activities must follow the Railroad's [Guidelines for Preparation of a Bridge Demolition and Removal Plan for Structures Over Railroad](#).

14.4.1 Key Considerations

Key considerations related to demolition are as follows:

- The Applicant and its Contractor shall be responsible for planning and executing all procedures necessary to remove the structure in a safe, predictable manner.
- The Contractor's work shall in no way impede train operations. The Contractor shall develop a demolition plan only after consulting with the Railroad to get an estimate of potential track time that might be normally available for the specific location.

- Introduction to this Manual
- Process Summary for Public Projects
- Active Grade Crossing Warning Systems including Preemption Requirements
- Grade Crossings
- Grade Separation Projects
- Sidewalks and Pathways
- Parallel Corridor and Other Projects
- Quiet Zones (QZ)
- Bridge Painting, Railroad Property Beautification, and Maintenance
- Engineering Submittal Requirements and Review Schedule
- Payment of UP's Cost, Expenses and Insurance
- Agreements and Rights of Entry
- Railroad Flagging/Protection for Activities On/Near Railroad Property
- Construction Monitoring Requirements**
- Utility Locates, Crossings, and Protection
- Public Safety Initiatives
- Additional Resources

- The tracks and the Railroad Property shall be protected at all times, and demolition procedures shall account for severe weather conditions, site security, and site accessibility.
- No work is allowed within 25 feet of the nearest track unless protected by a Railroad Flagger. When trains approach the work site, all demolition activity within 50 feet of the track shall stop until the entire length of the train has passed the work site and the Flagger has instructed that demolition can resume.
- All demolition should occur in a safe and controlled manner. Every effort should be made to avoid dropping material on the tracks. If necessary to drop material on the tracks, protection should be provided per the [Guidelines for Preparation of a Bridge Demolition and Removal Plan for Structures Over Railroad](#).
- No blasting will be permitted on the Railroad ROW.

14.4.2 Demolition Plan

The Applicant or its Contractor shall submit a complete demolition plan to the Railroad. The plan shall include details, procedures, and sequence of staged removal, including all steps necessary to remove the structure in a safe and controlled manner.

- A demolition plan is required for any demolition activity on or near the Railroad Property. This plan must be sealed by a Professional Engineer registered in the state in which the work is to be completed, with the Professional Engineer responsible for addressing all required parameters of the demolition plan.
- The Applicant must first review and approve the demolition plan prior to submission to the Railroad.
- Review of and comment on the demolition plan by the Railroad will not relieve the Applicant and its Contractor of the ultimate responsibility and liability for the demolition.
- An onsite demolition meeting is mandatory for all demolition activities. Representatives of the Applicant, its Contractor, any applicable public agency, and the Railroad shall be present.

The purpose is to confirm that all processes and equipment are in place to proceed per the demolition plan, otherwise track authority will not be provided.

- Deviations or modifications to the original demolition plan require additional review by the Railroad.
- Additional details of the requirements and procedure of the demolition plan can be found in UP's [Guidelines for Preparation of a Bridge Demolition and Removal Plan for Structures Over Railroad](#).

14.5 Construction Crane Encroachments

This section addresses lifting activities using cranes or similar equipment near Railroad Property, which has the potential to impact the safety of Railroad employees and Railroad operations. The overriding goal is to verify the necessary planning, engineering, and execution to avoid equipment or material failures that can lead to safety issues or unplanned interruptions.

14.5.1 Key Considerations

Key considerations related to construction crane encroachments are as follows:

- A lifting plan is required for any lifting activity on or near Railroad Property. This plan must be sealed by a Professional Engineer registered in the state in which the work is to be completed, with the Professional Engineer responsible for addressing all required parameters of the lifting plan.
- The Applicant must first review and approve the lifting plan prior to submission to the Railroad.
- An onsite pre-lift safety meeting is mandatory for all lifting activities. Representatives of the Applicant, its Contractor, any applicable public agency, and the Railroad shall be present. The purpose is to confirm that all processes and equipment are in place to proceed per the lifting plan, otherwise track authority will not be provided

- Introduction to this Manual
- Process Summary for Public Projects
- Active Grade Crossing Warning Systems including Preemption Requirements
- Grade Crossings
- Grade Separation Projects
- Sidewalks and Pathways
- Parallel Corridor and Other Projects
- Quiet Zones (QZ)
- Bridge Painting, Railroad Property Beautification, and Maintenance
- Engineering Submittal Requirements and Review Schedule
- Payment of UP's Cost, Expenses and Insurance
- Agreements and Rights of Entry
- Railroad Flagging/Protection for Activities On/Near Railroad Property
- Construction Monitoring Requirements**
- Utility Locates, Crossings, and Protection
- Public Safety Initiatives
- Additional Resources

The use of cranes or other lifting equipment shall not cause interruption to Railroad operations.

- Deviations or modifications to the original lifting plan require additional review by the Railroad.
- Train operations will not be permitted during splicing, post tensioning, or any activities performed during a suspended load until structural stability is achieved. For these reasons, superstructures of these types are not recommended. The method of erection permissible will be dependent upon available track time as coordinated through the Railroad site representative during construction.
- Prior to the release of Railroad traffic, components lifted over live tracks shall be supported by falsework or permanent substructure, shall be secured and stable, and shall not be supported by cranes or other construction equipment.
- When cranes are operated over or adjacent to the tracks, the Contractor shall verify that the foundations and soil conditions under the crane and crane outriggers can support the maximum loads induced by the crane under an assumed maximum capacity lift. The size and material type of crane mats shall be rigid and of sufficient capacity to safely distribute the crane loads.
- Additional track protection may be required for a crane when crossing over the track. The protection methods shall be submitted to the Railroad for review and comment in advance of intended use.
- Cranes and other equipment using outriggers shall not place outriggers on the Railroad tracks or Ballast.
- During passage of a train, the crane operator must stop all movements and remain in the cab with engine at idle and with the load lines, boom, rotation, and travel controls locked and stationary until the full length of the train has passed the job site and the Flagger has instructed that demolition can resume.

- The Applicant should use every effort to use existing crossings if access on the opposite side of the tracks is necessary. Installation of temporary track crossings is strongly discouraged.

14.6 Falsework Requirements/Shoring

Falsework clearance shall comply with minimum temporary construction clearances per the UP and BNSF [Guidelines for Railroad Grade Separation Projects](#) and [UP's Guidelines for Temporary Shoring](#). The design of all structural members for falsework shall comply with AREMA and Railroad requirements. Any falsework system should be designed to minimize any potential interruptions to Railroad operations (e.g. use precast components and avoid cast in place). Prior to commencing any work, the contractor shall submit for approval by the Railroad detailed indicated the nature and extent of the track protection shoring proposed.

Shoring must be designed for Railroad live load surcharge in addition to OSHA Standard loads for excavation in Zone A and B. Applicable Railroad Live Load is Cooper E80.

14.7 Shop Drawings and Material Verifications

UP has a process that must be followed when a party other than UP will be supplying materials for UP owned and maintained tracks. The format for the required cover letter must be followed.

See the UP's instructions and tracking spreadsheet on the [UP website](#).

The Shop Drawing Submittal Tracking Sheet must be utilized during the project construction



- Introduction to this Manual
- Process Summary for Public Projects
- Active Grade Crossing Warning Systems including Preemption Requirements
- Grade Crossings
- Grade Separation Projects
- Sidewalks and Pathways
- Parallel Corridor and Other Projects
- Quiet Zones (QZ)
- Bridge Painting, Railroad Property Beautification, and Maintenance
- Engineering Submittal Requirements and Review Schedule
- Payment of UP's Cost, Expenses and Insurance
- Agreements and Rights of Entry
- Railroad Flagging/Protection for Activities On/Near Railroad Property
- Construction Monitoring Requirements
- Utility Locates, Crossings, and Protection**
- Public Safety Initiatives
- Additional Resources



Section 15 Utility Locates, Crossings, and Protection

15.1 Overview

All new or relocated utilities within the Railroad ROW will require the Railroad's prior review and approval. The protection of Railroad signal and communication assets is paramount to safe train operations. Work on or adjacent to Railroad ROW has the potential to impact existing signal and communications infrastructure and shall be coordinated with the Railroad prior to the start of construction. The appropriate measures for the installation and protection of the signal, communications, and fiber optic cables shall be addressed in the plans and contract documents and shall be approved by the Railroad prior to construction.

The following is to be used as a guideline and once the application is made, detailed directions will be provided by the UP Real Estate Representative. Refer to the [UP website](#) for the current information and procedures.

15.2 UP Signal and Communication Cable Locates and Protection

Key considerations related to UP signal and communication cable locates and protection are as follows:

- The Applicant shall be responsible for the identification, location, protection, and relocation of all existing overhead and underground utilities.

The Applicant or Contractor must call the Railroad "Call Before You Dig" hotline (1-800-336-9193) to arrange for a Railroad-specific underground cable locate or exploration before any work or excavation commences.

- This "Call Before You Dig" number hotline (1-800-336-9193) is specific to the Railroad and will not include any utilities outside of the Railroad Property.
- The Applicant shall contact UP's Grade Crossing/Signal Hotline at 1-800-848-8715 separately for signal locates.
- The Contractor must cease all work and notify the Railroad immediately before continuing excavation in the area if obstructions are encountered that do not appear on the project plans or were not previously located.
- If a Railroad signal and communication asset is severed or damaged, the Contractor must immediately contact the Emergency Response Hotline at 1-888-UPRR COP (1 888-877-7267) and the Railroad project representative.
- Note the type of signal protection at Grade Crossings and the location of insulated joints in the track(s) where applicable, and whether modifications to any of these facilities are required.

Any regionally, state, or locally mandated "Call Before You Dig" hotlines and processes do not include Railroad utilities or signals.

15.2.2 Utility Guidelines

Fiber optic cables may be presently buried on the Railroad ROW or such installations may be scheduled. The presence of such facilities shall be considered in the project design, and appropriate measures for the installation and protection of the fiber optic cables shall be addressed in the plans and contract documents. Appropriate measures for the installation, protection, and relocation of fiber optic cables as well as the Railroad signal and communication lines shall be addressed in the plans and contract documents.

- Introduction to this Manual
- Process Summary for Public Projects
- Active Grade Crossing Warning Systems including Preemption Requirements
- Grade Crossings
- Grade Separation Projects
- Sidewalks and Pathways
- Parallel Corridor and Other Projects
- Quiet Zones (QZ)
- Bridge Painting, Railroad Property Beautification, and Maintenance
- Engineering Submittal Requirements and Review Schedule
- Payment of UP's Cost, Expenses and Insurance
- Agreements and Rights of Entry
- Railroad Flagging/Protection for Activities On/Near Railroad Property
- Construction Monitoring Requirements
- Utility Locates, Crossings, and Protection**
- Public Safety Initiatives
- Additional Resources

15.2.3 General Process

Before excavating, the Applicant or Contractor must determine whether any underground pipelines, electric wires, or cables, including fiber optic cable systems (for signals or communications) are present and located within the project work area. The Applicant or Contractor must determine whether excavation on Railroad Property could cause damage to buried cables, resulting in delay to rail traffic and service disruption to users. Service delays may cause business interruptions involving loss of revenue and profits. All underground and overhead wires will be considered high voltage and dangerous until verified with the company having ownership of the line.

The Contractor must cease all work and notify the Railroad immediately before continuing excavation in the area if obstructions are encountered that do not appear on the project plans or that were not previously located. If the obstruction is a utility and the owner of the utility can be identified, then the Contractor must also notify the owner immediately. If there is any doubt about the location of underground cables or lines of any kind, no work must be performed until the exact location has been determined. There will be no exceptions to these instructions.

15.3 Utility Locates within UP Right of Way

The Applicant or Contractor is responsible for notifying any other companies that have underground utilities in the area and arranging for the location of all underground utilities before excavating.

Any regionally, state, or locally mandated "Call Before You Dig" hotlines and processes do not include Railroad utilities or signals.

Similar to obtaining survey, a non-intrusive survey request is required prior to performing locates for utilities on Railroad Property. The **Permit to be on Railroad Property for Nonintrusive Civil Engineering Survey Work** form must be printed, executed, and returned following the instructions given in the permit.

15.4 Utility Crossings

UP has an online process for public and private pipeline and wireline utility Crossings of the Railroad Property. This process is for installation, modification, or maintenance of the utility.

The process for utilities is separate from the MPP or PP-EC and should be directed to the appropriate UP Real Estate Manager.

This **online application process** will allow you to complete an application for a pipeline or wireline Crossing, Encroachment, modification, or maintenance request. This will save you time and money, avoiding the delays, expense, and uncertainty of mailing applications. All applications mentioned above must be submitted online.

If an installation entails both an Encroachment and a Crossing, procedures for both must be followed in the application process. The application must be submitted through the Encroachment and Crossing option, and the application cannot be rushed.

If the installation method for this utility is to involve the use of a directional drilling method, specific Guidelines established by the Railroad must be met. UP follows the AREMA Manual for Railway Engineering, Chapter 1 - PART 5 Pipelines. To purchase a copy of these AREMA Guidelines, send an application to AREMA.

A Railroad ROE (if applicable), per **Section 12.2.1**, is required to survey or abandon existing utilities within the Railroad corridor. The Railroad has no obligation to provide property for relocated utilities that do not comply with the Railroad's standard specifications and requirements, including, but not limited to, AREMA and these Guidelines.

- Introduction to this Manual
- Process Summary for Public Projects
- Active Grade Crossing Warning Systems including Preemption Requirements
- Grade Crossings
- Grade Separation Projects
- Sidewalks and Pathways
- Parallel Corridor and Other Projects
- Quiet Zones (QZ)
- Bridge Painting, Railroad Property Beautification, and Maintenance
- Engineering Submittal Requirements and Review Schedule
- Payment of UP's Cost, Expenses and Insurance
- Agreements and Rights of Entry
- Railroad Flagging/Protection for Activities On/Near Railroad Property
- Construction Monitoring Requirements
- Utility Locates, Crossings, and Protection**
- Public Safety Initiatives
- Additional Resources

A topographic map with street names (old and new, if applicable) showing the proposed installation, with reference information of a fixed object identity on a known railroad subdivision, will be required. Appropriate measures for the installation, protection, and relocation of fiber optic cables as well as Railroad signal and communication lines shall be addressed in the plans and contract documents.

Depending on the scope of the work and proximity to UP tracks, RPLI may be required in addition to general liability insurance. The licensee shall have in place, and in full force during the life of the agreement, General Liability, Automotive Liability, Worker's Compensation, and Employer's Liability. See [Section 11.5](#) or [General Insurance Requirements](#).

Additional costs for construction monitoring will be paid by the Applicant.

15.4.1 Pipeline Crossings

UP's [Pipeline Installation Procedures for Crossings](#) are available on its website. Also see UP's website for a [Sample Encased Non-Flammable Pipeline Crossing Exhibit A](#). A portion of this exhibit is shown in [Figure 15.1](#) below.

Figure 15.1 Encased Non-Flammable Pipeline

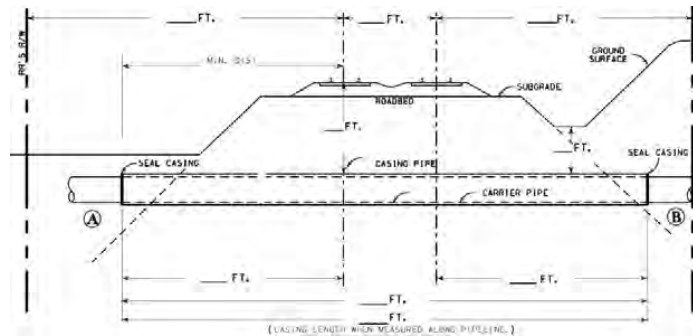

Similarly, UP's website includes an [Exhibit A for Gas \[Non-Liquid Natural State\] Flammable and Non-Flammable Pipeline Crossing](#), partially shown in [Figure 15.2](#) below.

Figure 15.2 Gas (Non-Liquid Natural State) Flammable Pipeline

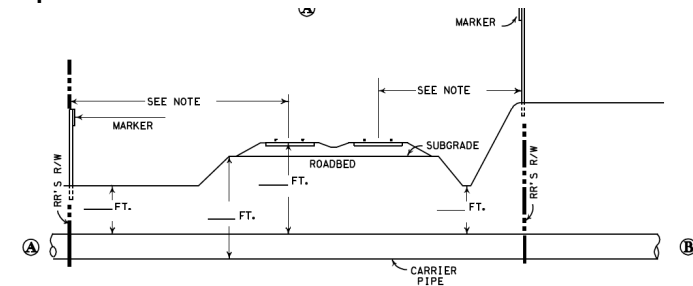

15.4.2 Wireline Crossings

UP's [Wireline Installation Procedures for Crossings](#) are available on its website.

There are various types of overhead and underground wireline crossing Exhibit A samples on UP's website (750 volts or less and over 750 volts). A portion of the [Overhead 750 volts or less Exhibit A](#) is shown in [Figure 15.3](#) below. The traffic signal interconnect cables do not require a wireline crossing, they are included with the Railroad agreements.

Figure 15.3 Overhead Wireline Crossing

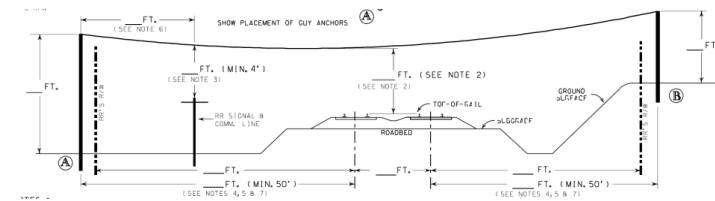

- Introduction to this Manual
- Process Summary for Public Projects
- Active Grade Crossing Warning Systems including Preemption Requirements
- Grade Crossings
- Grade Separation Projects
- Sidewalks and Pathways
- Parallel Corridor and Other Projects
- Quiet Zones (QZ)
- Bridge Painting, Railroad Property Beautification, and Maintenance
- Engineering Submittal Requirements and Review Schedule
- Payment of UP's Cost, Expenses and Insurance
- Agreements and Rights of Entry
- Railroad Flagging/Protection for Activities On/Near Railroad Property
- Construction Monitoring Requirements
- Utility Locates, Crossings, and Protection
- Public Safety Initiatives**
- Additional Resources



Section 16 Public Safety Initiatives

Union Pacific cares about the communities we serve and partners with organizations to promote rail safety. UP uses innovation and technology to enhance the safety and security of our employees, communities and customers. Our goal is zero accidents, injuries or fatalities involving employees, pedestrians, drivers and trains.

Union Pacific reminds drivers to always expect trains travelling from either direction, at any time, at all railroad crossings. Trains can take more than a mile to stop – after locomotive engineers apply emergency brakes. [See our Driver Rail Safety Tips here.](#)

Union Pacific, Public Road Authorities, and drivers all have a part to play in crossing safety. All Union Pacific crossings are safe. When a crossing is maintained to all applicable standards, the stage has been set for a reasonably prudent driver to cross safely.

16.1 Crossing Assessment Process

From 2000 to 2010, Union Pacific's crossing safety efforts produced substantial reductions in grade crossing incidents. In the last few years, incidents have hit a plateau. In an effort to continue to reduce the number of crossing incidents, UP developed a new approach utilizing "big data". This initiative is known as the Crossing Assessment Process (CAP). UP's goal is to develop a predictive model that would allow UP to identify factors that are statistically correlated with incidents at crossings. This model analyzes data to determine a set of statistically significant factors for all Union Pacific public at-grade crossings. This regression model is designed to start with an end product (crossing incidents) and works backward to identify the elements that created that product. The model uses data available to UP, including information from incident reports and physical crossing characteristics from the FRA inventory records. The model works to identify characteristics that are statistically correlated with higher frequency and/or severity of incidents.

The model categories crossings in three tiers. A Tier 1 or Tier 2 crossing has several statistically significant characteristics. Tier 3 does not have several statistically significant characteristics. CAP identifies crossings where further possible safety enhancements may have an impact. UP works closely with the FHWA, State Department of Transportation Officials and State Regulatory Agencies where we operate to exchange the information learned from CAP for the application and incorporation with the various Roadway Safety Improvement Programs.

The analytics behind CAP rely on raw data that are collected through publicly available sources and private sources, including many internal UP datasets that are proprietary and confidential.

- Introduction to this Manual
- Process Summary for Public Projects
- Active Grade Crossing Warning Systems including Preemption Requirements
- Grade Crossings
- Grade Separation Projects
- Sidewalks and Pathways
- Parallel Corridor and Other Projects
- Quiet Zones (QZ)
- Bridge Painting, Railroad Property Beautification, and Maintenance
- Engineering Submittal Requirements and Review Schedule
- Payment of UP's Cost, Expenses and Insurance
- Agreements and Rights of Entry
- Railroad Flagging/Protection for Activities On/Near Railroad Property
- Construction Monitoring Requirements
- Utility Locates, Crossings, and Protection
- Public Safety Initiatives**
- Additional Resources

16.2 UP CARES

USDOT studied train-vehicle incident reports over a 10-year period and found that 94 percent of public railroad crossing incidents were caused by risky driver behavior, such as driving around activated automatic gates. UP's Crossing Accident Reduction and Education Safety (**UP CARES**) public safety program allows the company to work with communities through a variety of outreach channels. State and local police help ensure drivers and pedestrians cross railroad tracks and participate in UP CARES operations. Officers riding inside the locomotive observe motorist behavior at railroad crossings and dispatch officers positioned nearby, if drivers ignore signals and warnings. Stopped drivers are reminded to follow rail-related traffic laws designed to keep them safe. Depending on the severity of the infraction, a citation may be issued. Offers also approach pedestrians who disregard rail safety laws. The goal of these operations is not to hand out citations, but to encourage safe behavior around the tracks.

16.3 Education

UP proudly supports the SAFE KIDS WORLDWIDE teaching parents and educators the safest ways to transport children and prevent rail-related injuries. Check out Start Safe travel's **rail safety tips**.

UP employees conduct rail safety presentations in our communities at no charge. Anyone can **request a presentation**, including neighborhood clubs, schools, churches, and private companies. We also encourage sharing our **rail safety education resources**.



UP outreach efforts also include annual digital and social media rail safety video campaigns urging pedestrians and drivers to use caution near railroad crossings. The campaigns include engaging videos shared through **Facebook**, **Twitter**, and **YouTube**, and encourage audiences to share videos, images, and rail safety ideas.

Introduction to this Manual

Process Summary for Public Projects

Active Grade Crossing Warning Systems including Preemption Requirements

Grade Crossings

Grade Separation Projects

Sidewalks and Pathways

Parallel Corridor and Other Projects

Quiet Zones (QZ)

Bridge Painting, Railroad Property Beautification, and Maintenance

Engineering Submittal Requirements and Review Schedule

Payment of UP's Cost, Expenses and Insurance

Agreements and Rights of Entry

Railroad Flagging/Protection for Activities On/Near Railroad Property

Construction Monitoring Requirements

Utility Locates, Crossings, and Protection

Public Safety Initiatives

Additional Resources



Section 17 Additional Resources

17.1 UP Design Standards and Guidance

The following design standards and guidance sources provide additional information relevant to UP Public Projects with track or grade separation design:

- UP *Technical Specifications for Design and Construction of Track and Other Rail Related Infrastructure*
<https://www.up.com/emp/engineering/apps/archives/standards/public/index.cfm>
- UP *General Conditions and Specifications*
https://www.up.com/emp/engineering/mapcontent/standards/UP_GENERAL_SPECIFICATIONS.pdf
- UP *Guidelines for Contractor Material Delivery on Union Pacific Property*
https://www.up.com/emp/engineering/mapcontent/standards/GUIDELINES_FOR_CONTRACTORS_ON_UPRR_PROPERTY.pdf
- UP and BNSF *Guidelines for Temporary Shoring* (2004)
https://www.up.com/emp/engineering/mapcontent/standards/GUIDELINES_FOR_TEMPORARY_SHORING.pdf
- UP and BNSF *Guidelines for Railroad Grade Separation Projects* (2016)
https://www.up.com/cs/groups/public/documents/document/pdf_rr_grade_sep_projects.pdf
- UP *Demolition Guidelines* (1998)
https://www.up.com/cs/groups/public/@uprr/@realestate/documents/up_pdf_natedocspdf_up_reus_industry_demo.pdf

- UP Industry Guidelines
https://www.up.com/cs/groups/public/@uprr/@customers/@industrialdevelopment/@operationsspecs/@specifications/documents/up_pdf_natedocspdf_up_ind_ind-trk-const.pdf
- UP Track Design Guidelines for 3rd Party Public Projects Page
https://www.up.com/customers/ind-dev/operations/specs/public_projects/index.htm

17.2 External Sources

The following external sources provide additional information relevant to UP Public Projects:

- AREMA *Manual for Railway Engineering*, <http://www.arema.org>
- FHWA MUTCD, <http://mutcd.fhwa.dot.gov/>
- USDOT *Highway-Rail Crossing Handbook*, https://safety.fhwa.dot.gov/hsip/xings/com_roaduser/07010/index.cfm
- FRA Office of Safety Analysis website (for USDOT inventory number lookup)
<http://safetydata.fra.dot.gov/OfficeofSafety/Default.aspx>
- FRA Safety Map (for USDOT inventory number lookup), <http://fragis.fra.dot.gov/GISFRASafety/>
- FRA *The Train Horn Rule and Quiet Zones*, <https://www.fra.dot.gov/Page/P0889>
- FHWA, Federal-Aid Policy Guide, Subchapter G – Engineering and Traffic Operations, Part 646 – Railroads, Subpart B - Railroad-Highway Projects, <https://www.fhwa.dot.gov/legregs/directives/fapg/cfr0646b.htm>



- Introduction to this Manual
- Process Summary for Public Projects
- Active Grade Crossing Warning Systems including Preemption Requirements
- Grade Crossings
- Grade Separation Projects
- Sidewalks and Pathways
- Parallel Corridor and Other Projects
- Quiet Zones (QZ)
- Bridge Painting, Railroad Property Beautification, and Maintenance
- Engineering Submittal Requirements and Review Schedule
- Payment of UP's Cost, Expenses and Insurance
- Agreements and Rights of Entry
- Railroad Flagging/Protection for Activities On/Near Railroad Property
- Construction Monitoring Requirements
- Utility Locates, Crossings, and Protection
- Public Safety Initiatives
- Additional Resources**

17.3 Glossary

The following glossary of terms are used and capitalized throughout this manual:

AASHTO Green Book: The current edition of the American Association of State Highway and Transportation Officials, A Policy on Geometric Design of Highways and Streets (The Green Book)

Access Road: A road used and controlled by the Railroad for maintenance, inspection and repair.

Active Grade Crossing Warning System: The Flashing-Light Signals, with or without warning gates, together with the necessary control equipment used to inform road users of the approach or presence of rail traffic at grade crossings.

Advance Preemption: The notification of approaching rail traffic that is forwarded to the highway traffic signal controller unit or assembly by the railroad or light rail transit equipment in advance of the activation of the railroad Grade Crossing Warning System.

Advance Preemption Time: The period of time between notification to the traffic signal controller of an approaching train and the instant when the Active Grade Crossing Warning System is activated is known as Advance Preemption Time (APT).

Agency (Regulatory Agency): Any public agency that regulates railroad safety. For example a public utilities commission. (California Public Utilities Commission, Illinois Commerce Commission, Wisconsin Office of the Commissioner of Railroads)

Alternative Safety Measure (ASM): Is a safety system or procedure established in accordance with Federal rules governing Quiet Zones which is provided by the appropriate traffic control authority or law enforcement authority responsible for safety at the Highway-Rail Grade Crossing, that is determined by the FRA to be an effective substitute for the

locomotive horn in the prevention of highway-rail casualties.

Americans with Disabilities Act (ADA) of 1990: A civil rights law that prohibits discrimination based on disability. Refers to the ADA of 1990 (PL 101-336) and the ADA Amendments Act of 2008 (PL 110-325).

Applicant: Any external party including, but not limited to, a public agency or private party proposing a project on or near the Railroad Property, regardless of track being active or dormant. The typical Applicant include a citizen, consultant, contractor, developer, government, industry, other railroad, Public Road Authority, or UP Customer.

AREMA: American Railway Engineering and Maintenance-of-Way Association is a not-for-profit corporation made of members in the railway industry. The mission of the Association is the development and advancement of both technical and practical knowledge, and recommended practices pertaining to the design, construction, and maintenance of railway infrastructure.

AREMA Manual: The current edition of the American Railway Engineering and Maintenance-of-Way Association Manual for Railway Engineering including the portfolio drawings.

At-Grade Crossing: See also Highway-Rail Grade Crossing

Ballast: Material placed on a track roadbed to hold the track in alignment and elevation. It consists of crushed stone, generally 1 to 2 inches in size, angular, rough surfaced, clean and free of sand, loam, clay, flat, elongated, soft, or disintegrated pieces, and other deleterious substances.

Cantilevered Signal Structure: A structure, also referred to as a mast arm, rigidly attached to a vertical pole and is used to provide overhead support of grade crossing signal units.

Channelization Device: A traffic separation system made up of a raised longitudinal channelizer with vertical panels or tubular delineators. These devices can serve several purposes such as being placed between opposing highway lanes designated to alert or guide traffic or pedestrians in a particular direction, or

- Introduction to this Manual
- Process Summary for Public Projects
- Active Grade Crossing Warning Systems including Preemption Requirements
- Grade Crossings
- Grade Separation Projects
- Sidewalks and Pathways
- Parallel Corridor and Other Projects
- Quiet Zones (QZ)
- Bridge Painting, Railroad Property Beautification, and Maintenance
- Engineering Submittal Requirements and Review Schedule
- Payment of UP's Cost, Expenses and Insurance
- Agreements and Rights of Entry
- Railroad Flagging/Protection for Activities On/Near Railroad Property
- Construction Monitoring Requirements
- Utility Locates, Crossings, and Protection
- Public Safety Initiatives
- Additional Resources**

as a fencing system used to separate modes, (e.g. channelize pedestrian)

Clear Zone: The total roadside border area, starting at the edge of the Traveled Way, available for safe use by errant vehicles. This area may consist of a Shoulder, a recoverable slope, a non-recoverable slope, and/or a clear run-out area.

Constant Warning Time: A means of detecting rail traffic that provides road users with relatively uniform warning times prior to the approach of through trains that neither accelerate nor decelerate after having been detected.

Construction and Maintenance (C&M) Agreement: A Construction and Maintenance Agreement that has been negotiated between the Railroad and the Applicant that addresses all the duties and responsibilities of each party regarding the construction of the proposed Public Project and the maintenance requirements after construction

Construction Documents: Design plans and calculations, project and/or standard specifications, geotechnical report and drainage report.

Contractor: The individual, partnership, corporation or joint venture and all principals and representatives (including Applicant's subcontractors) with whom the contract is made by the Applicant for the construction of the Public Project.

Crossing (Utility): A crossing is a utility pipeline or wireline that enters the railroad company's trackage from one side of the ROW to the other side of the ROW in as near a straight line as possible.

Crossing Surface: The area between track ties that are used by either vehicles, bicycles or pedestrians to traverse over the railroad. Also known as planking. The material could be concrete, timber, rubber, composite or asphalt.

Crossover: A track connection which allows trains and on-track equipment to cross from one track to another.

Curfew: A time frame in which construction or maintenance can be performed by the Contractor with the required presence of a Flagger.

Design Vehicle: The longest vehicle permitted by statute of the road authority (State or other) on that Roadway.

Diagnostic Team: A group of knowledgeable representatives of parties of interest in a Highway-Rail Grade Crossing, organized by the Public Authority responsible for that crossing, who, using crossing safety management principles, evaluate conditions at a grade crossing to make determinations or recommendations for the Public Authority concerning safety needs at that crossing.

DocuSign: A third-party web-based document signing system used for signing railroad agreements.

Easement: A right to use or control the property of another for a designated purpose. Crossing Agreements may include Temporary and Permanent Easements. All other types of Easements are considered License Permits and are submitted online through UP Utility page.

Encroachment (Real Estate): A real estate Encroachment is a private or public feature that sits inside the UP's Property. It could be a parking lot, fence, building, landscaping, shed, storage materials, equipment, etc. Encroachments typically need to be removed or the owner of the feature needs to enter into a lease agreement to continue Encroachment.

- **Drainage Encroachment:** A drainage feature or pipe that does not cross the tracks, but rather is within the ROW.
- **Beautification Encroachment:** Any work proposed to utilize the RR ROW for landscaping, painting, signs, etc. (These are both Submitted as a License Application similar to a utility)

Encroachment (Utility): A utility Encroachment is a pipeline or wireline that enters the Railroad ROW and either does not leave the ROW or follows along the ROW for some distance.

Engineer-of-Record: The Professional Engineer that develops the criteria and concept for the project and is responsible for the preparation of the Plans and Specifications. Final Plans: 100% plans signed and stamped by the Engineer-of-Record.

Flagger: A qualified employee of the Railroad providing protection to and from Railroad operations per Railroad requirements.

Flashing-Light Signal: An Active Grade Crossing Warning System consisting of two red signal indications arranged

- Introduction to this Manual
- Process Summary for Public Projects
- Active Grade Crossing Warning Systems including Preemption Requirements
- Grade Crossings
- Grade Separation Projects
- Sidewalks and Pathways
- Parallel Corridor and Other Projects
- Quiet Zones (QZ)
- Bridge Painting, Railroad Property Beautification, and Maintenance
- Engineering Submittal Requirements and Review Schedule
- Payment of UP's Cost, Expenses and Insurance
- Agreements and Rights of Entry
- Railroad Flagging/Protection for Activities On/Near Railroad Property
- Construction Monitoring Requirements
- Utility Locates, Crossings, and Protection
- Public Safety Initiatives
- Additional Resources**

horizontally that are activated to flash alternately when rail traffic is approaching or present at a Highway-Rail Grade Crossing.

Force Account: The estimated portion of a Public Project's civil, track, flagging, inspection or signal costs that would be the responsibility of the Railroad.

FRA: Federal Railroad Administration

Future Track: The Railroad has the right to expand operations within the existing ROW corridor. Future tracks may be added either side of the existing track. Therefore, structures should fully span the ROW.

Grade Crossing: See also Highway-Rail Grade Crossing.

Grade Separation Project: A project that includes an overpass or underpass structure that crosses the Railroad ROW or other Railroad operating location regardless of track status being active or out of service.

Guidelines: Information contained in this document or referenced in AREMA or AASHTO.

Horizontal Clearance: Distance measured perpendicular from the centerline of the nearest track to the nearest edge of any obstruction.

Highway-Rail Grade Crossing: A location where a highway, road, or street and the railroad ROW cross at the same level, within which are included the railroad tracks, highway, and Traffic Control Devices for highway traffic traveling over the railroad tracks.

Interconnection: The electrical connection between the railroad active warning system and the highway traffic signal controller assembly for the purpose of Preemption.

Light Rail Transit (LRT): LRT is a mode of metropolitan transportation that employs LRT vehicles (commonly known as light rail vehicles, streetcars, or trolleys) that operate on rails in streets in mixed use traffic, and LRT traffic that operates in semi-exclusive rights-of-way, or in exclusive rights-of-way. Grade crossings with LRT can occur at intersections or at midblock locations, including public and private driveways.

Mainline Track: A principle track, designated by Timetable or

special instructions, upon which train movements are generally authorized and controlled by the train dispatcher. Main Track must not be occupied without proper authority.

Manager of Public Projects (MPP): Railroad representative responsible for providing overall management of public grade crossing and Grade Separation Projects.

Manager of Signal Maintenance (MSM): Railroad representative responsible for the maintenance of a specific section of Active Grade Crossing Warning Systems and the wayside signal system.

Manager of Track Maintenance (MTM): Railroad representative responsible for maintenance of a specific section of track and supporting roadbed.

Manual on Uniform Traffic Control Devices (MUTCD): The MUTCD is a document published by the FHWA that specifies the standards and requirements for the installation of Traffic Control Devices such as traffic Signs, markings, and signals to be used on all public Roadways, bikeways, and private roads open to the public in the U.S. States and their subdivisions must either comply with the MUTCD or adopt an alternative manual approved by the FHWA. Highway-Rail Grade Crossings are addressed in Section 8 of the MUTCD.

Median: The area between two Roadways of a divided highway measured from edge of Traveled Way to edge of Traveled Way. The Median excludes turn lanes. The Median width might be different between intersections, interchanges, and at opposite approaches of the same intersection. If used for a Quiet Zone, refer to the Final Rule on the Use of Locomotive Horns at Highway-Rail Grade Crossings (49 CFR Part 222).

Minimum Warning Time: The least amount of time the Active Grade Crossing Warning System is designed to remain activated prior to the arrival of a train at a Highway-Rail Grade Crossing.

Multiple Main Tracks: Two or more parallel or adjacent Main

- Introduction to this Manual
- Process Summary for Public Projects
- Active Grade Crossing Warning Systems including Preemption Requirements
- Grade Crossings
- Grade Separation Projects
- Sidewalks and Pathways
- Parallel Corridor and Other Projects
- Quiet Zones (QZ)
- Bridge Painting, Railroad Property Beautification, and Maintenance
- Engineering Submittal Requirements and Review Schedule
- Payment of UP's Cost, Expenses and Insurance
- Agreements and Rights of Entry
- Railroad Flagging/Protection for Activities On/Near Railroad Property
- Construction Monitoring Requirements
- Utility Locates, Crossings, and Protection
- Public Safety Initiatives
- Additional Resources**

Tracks.

Near Rail: The center of the closest steel rail. This is used to measure certain horizontal clearances.

Overpass Grade Separation: A Roadway, pedestrian, or Pathway structure which passes over the Railroad Property or Railroad ROW (Overpass Structure).

Oversize/Overweight Transport Vehicle Requests: Transport vehicles that are used to haul houses, large equipment, windmills, etc. that might require track equipment (gates, signals, or overhead lines etc.) to be temporarily relocated for the vehicle to traverse the UP ROW.

Passive Grade Crossing: A grade crossing where none of the automatic Traffic Control Devices associated with an Active Grade Crossing Warning System are present and at which the Traffic Control Devices consist entirely of Signs and/or markings.

Passive Traffic Control Device: A Traffic Control Device, such as a highway sign or pavement marking, located at or in advance of an at-grade Roadway/railway crossings that indicates the presence of a Highway-Rail Grade Crossing but does not activate or change upon the approach or presence of a train. Passive Warning Devices may include crossbucks, stop or yield Signs, and pavement markings.

Pathway: A general term denoting a public way for purposes of travel by authorized users outside the Traveled Way and physically separated from the Roadway by an open space or barrier and either within the highway ROW or within an independent alignment. Pathways do not include Sidewalks, however, includes shared-use paths, trails, and multi-use paths.

Pathway Grade Crossing: The general area where a Pathway and railroad tracks cross at the same level, within which are included the tracks, Pathway, and Traffic Control Devices for Pathway traffic traversing that area.

Preemption (Traffic Signal Interconnect): The transfer of normal operation of a traffic control signal to a special control mode of operation.

Preliminary Engineering: An early phase of project analysis and design work that typically develops construction plans, specifications, and cost estimates.

Private Grade Crossing: An at-grade crossing of a private Roadway with a railroad line. Private grade crossings are on privately owned Roadways, such as on a farm or in an industrial area, and are intended for use by the owner or by the owner's licensees and invitees. A Private Crossing is not intended for public use and is not maintained by a public highway authority. Private Crossing owner is responsible for having a Private Crossing agreement.

Public Crossing: An at-grade crossing of a public Roadway with a railroad line. Public grade crossings are Roadways that are under the jurisdiction of, and maintained by, a public agency (city, county, or state) and open to public travel.

Public Project: Any Roadway, bridge, commercial development, parallel corridor, or utility project that is owned or used by the public or by a private entity and that encroaches within Railroad Property

Public Project - Consultant (PP-EC): Consultant hired by UP to assist the MPP in processing Public Projects.

Public Project Tracking System (PPTS): Internal UP electronic system used to store agreements, process purchase orders for UP force account work associated with a Public Project and invoice Applicants after a RA is executed.

Public Road Authority (Public Authority): The public entity responsible for traffic control or law enforcement at the public highway-rail grade or pedestrian crossing.(includes Public Authority for a Quiet Zone)

Quiet Zone or Quiet Zone Rule: A segment of a rail line, with one or a number of consecutive public Highway-Rail Grade

- Introduction to this Manual
- Process Summary for Public Projects
- Active Grade Crossing Warning Systems including Preemption Requirements
- Grade Crossings
- Grade Separation Projects
- Sidewalks and Pathways
- Parallel Corridor and Other Projects
- Quiet Zones (QZ)
- Bridge Painting, Railroad Property Beautification, and Maintenance
- Engineering Submittal Requirements and Review Schedule
- Payment of UP's Cost, Expenses and Insurance
- Agreements and Rights of Entry
- Railroad Flagging/Protection for Activities On/Near Railroad Property
- Construction Monitoring Requirements
- Utility Locates, Crossings, and Protection
- Public Safety Initiatives
- Additional Resources**

Crossings at which locomotive horns are not routinely sounded per 49 CFR Part 222.

Railroad: Union Pacific Railroad.

Railroad Property: The private property limits and ROW owned by the Railroad.

Regulatory Agency (Agency): See term definition under Agency.

Reimbursement Agreement (RA): Intended to reimburse the Railroad for costs and expenses associated with the preliminary review of a project. This does not assume Railroad approval for any reason directly or indirectly related to safety or its operations, property issues or effect to its facilities.

Response Management Communication Center (RMCC): UP's incident reporting and critical call center for incidents that occur on Railroad ROW

Right of Entry Permit (ROE): A permit granted by the Railroad to an Applicant or a Contractor allowing access to Railroad Property.

Right of Way (ROW): A general term denoting land, property, or interest therein, usually in a strip, acquired for or devoted to transportation purposes. Alternately, ROW is also a term that confers to a road user or train the priority to proceed in preference to other vehicles or pedestrians, depending upon the rules of the road and Traffic Control Devices in use.

Roadway: The portion of a highway improved, designed, or ordinarily used for vehicular travel and parking lanes, but exclusive of the Sidewalk, berm, or Shoulder even though such Sidewalk, berm, or Shoulder is used by persons riding bicycles or other human-powered vehicles.

Shoofly: A temporary track built to bypass an obstruction or construction site.

Shoulder: The portion of the Roadway adjacent to the Traveled Way that is primarily intended for accommodation of stopped vehicles for emergency use and for lateral support of base and pavement surface courses.

Sidewalk: That portion of a street between the curb line, the lateral line of a Roadway, and the adjacent property line or on Easements of private property that is paved or improved and intended for use by pedestrians. (Typically part of the Highway-Rail Grade Crossing)

Siding: A track connected to the Main Track used for storing or passing trains.

Sign: Any Traffic Control Device that is intended to communicate specific information to road users through a word, symbol, and/or arrow legend. Signs do not include highway traffic signals, pavement markings, delineators, or Channelization Devices.

Signal Bungalow: The railroad's signal controller containing circuit boards, power, and monitoring the Active Grade Crossing Warning System at a Highway-Rail Grade Crossing.

Simultaneous Preemption: Notification of approaching rail traffic is forwarded to the highway traffic signal controller unit or assembly and railroad Active Grade Crossing Warning System at the same time.

Structure Type Selection Report: The report UP requires when a new Grade Separation or modifications to an existing Grade Separation is proposed. The Type Selection Report should include exhaustive alternative analysis and design which does not utilize the UP ROW, does not limit UP's ability to protect and preserve the UP ROW, and is not solely based on cost.

Supplemental Safety Measure (SSM): Is a safety system or procedure established in accordance with Federal rules governing Quiet Zones which is provided by the appropriate traffic control authority or law enforcement authority responsible for safety at the Highway-Rail Grade Crossing, that is determined by the FRA to be an effective substitute for the locomotive horn in the prevention of highway-rail casualties.

Timetable: A Railroad publication with instructions on train, engine, or equipment movement. It also contains other essential

- Introduction to this Manual
- Process Summary for Public Projects
- Active Grade Crossing Warning Systems including Preemption Requirements
- Grade Crossings
- Grade Separation Projects
- Sidewalks and Pathways
- Parallel Corridor and Other Projects
- Quiet Zones (QZ)
- Bridge Painting, Railroad Property Beautification, and Maintenance
- Engineering Submittal Requirements and Review Schedule
- Payment of UP's Cost, Expenses and Insurance
- Agreements and Rights of Entry
- Railroad Flagging/Protection for Activities On/Near Railroad Property
- Construction Monitoring Requirements
- Utility Locates, Crossings, and Protection
- Public Safety Initiatives
- Additional Resources**

Railroad information.

Top of Rail: The top of the steel rail; the point where train wheels bear on the steel rails. Use the higher of the two rails when track is superelevated. This is the base point for railroad Vertical Clearance measurements.

Track Center: The horizontal mid-point between the two steel rails on a single track. The location of the track alignment for geometric design purposes and Horizontal Clearance measurements.

Track Center Spacing: The distance between adjacent Track Centers.

Track Clearance Green Time: The track clearance green time is the period of time programmed into the traffic signal controller with railroad preemption that the green indication is displayed to vehicles stopped within the minimum track clearance distance (MTCD). This time is determined by calculating the time required for a design vehicle of maximum length to start up and move clear of the MTCD prior to the arrival of the train under normal conditions.

Traffic Control Device: A Sign, signal, marking, or other device used to regulate, warn, or guide traffic, placed on, over, or adjacent to a street, highway, private road open to public travel, pedestrian facility, or shared-use path by authority of a public agency or official having jurisdiction, or, in the case of a private road open to public travel, by authority of the private owner or

private official having jurisdiction.

Traffic Signal Interconnect: The cables and system installed at a Highway-Rail Grade Crossing connecting the Railroad signal cabinet and the Roadway Authority traffic signal controller for an adjacent signalized traffic intersection, a traffic pre-signal, or traffic queue cutter signal preemption.

Trail: See Pathway

Traveled Way: The portion of the Roadway for the movement of vehicles, exclusive of Shoulders.

Underpass Grade Separation: Railroad structure over a Roadway and/or Pathway (Overpass Grade Separation).

UP or UPRR: Refers to the Union Pacific Railroad Company.

Utility Crossing: Refer to Crossing definition.

Vertical Clearance: Distance measured vertically from the top of the highest rail to the lowest obstruction under the structure. The required minimum Vertical Clearance is 23'-4" from Top of Rail to low point of the overhead structure.

Wayside Horn System: A stationary horn (or series of horns) located at a Highway-Rail Grade Crossing that is used in conjunction with train-Active Grade Crossing Warning Systems to provide audible warning of approaching rail traffic to road users on the highway or Pathway approaches to a grade crossing, either as a supplement or alternative to the sounding of a locomotive horn.

Yard: A system of tracks of defined limits, other than Main Tracks and Sidings, for storing and sorting cars and other purposes.

Yard Limit: A portion of Main Track designated by "yard limit" Signs and included in the Timetable special instructions or a track bulletin.

- Introduction to this Manual
- Process Summary for Public Projects
- Active Grade Crossing Warning Systems including Preemption Requirements
- Grade Crossings
- Grade Separation Projects
- Sidewalks and Pathways
- Parallel Corridor and Other Projects
- Quiet Zones (QZ)
- Bridge Painting, Railroad Property Beautification, and Maintenance
- Engineering Submittal Requirements and Review Schedule
- Payment of UP's Cost, Expenses and Insurance
- Agreements and Rights of Entry
- Railroad Flagging/Protection for Activities On/Near Railroad Property
- Construction Monitoring Requirements
- Utility Locates, Crossings, and Protection
- Public Safety Initiatives
- Additional Resources**

17.4 Abbreviations

The following abbreviations are used throughout this manual:

- AASHTO** = American Association of State Highway and Transportation Officials
- ADA** = Americans with Disabilities Act
- ADT** = average daily traffic
- AREMA** = American Railway Engineering and Maintenance-of-Way Association
- ASM** = Alternative Safety Measure (Quiet Zone rule)
- ATV** = all-terrain vehicle
- BNSF** = BNSF Railway
- CAP** = Crossing Assessment Process
- C&M** = Construction and Maintenance
- CFR** = Code of Federal Regulations
- Crossing** = At-Grade Crossing or Highway-Rail Grade Crossing
- DOT** = Department of Transportation
- EIS** = Environmental Impact Statement
- ENS** = Emergency Notification Sign
- FAPG** = Federal-Aid Policy Guide
- FHWA** = Federal Highway Administration
- FRA** = Federal Railroad Administration
- FSP** = Federal Railroad Signal Program - Section 130
- I/C** = inspector coordinator consultant
- LRT** = Light Rail Transit
- Manual** = Union Pacific Railroad Public Projects Manual
- MCL** = Maintenance Consent Letter Agreement
- MPP** = Manager of Public Projects

- PP-EC** = Manager of Public Projects - Consultants
- MPH or mph** = miles per hour
- MSE** = mechanically stabilized earth
- MSM** = Manager of Signal Maintenance
- MTM** = Manager of Track Maintenance
- MUTCD** = Manual on Uniform Traffic Control Devices, current version
- O&M** = operations and maintenance
- PDF** = Portable Document Format
- PO** = Purchase Order
- PPE** = personal protective equipment
- PPTS** = Public Project Tracking System
- PTC** = Positive Train Control
- RA** = Reimbursement Agreement
- Railroad** = Union Pacific Railroad
- REC** = Real Estate Consultant
- RPLI** = Railroad Protective Liability Insurance
- ROE** = Right of Entry Permit
- ROW** = Right of Way
- SET** = safety end treatment
- SSM** = Supplemental Safety Measure (Quiet Zone rule)
- T/R** = top-of-rail
- UAS** = Unmanned Aircraft System
- UP** = Union Pacific Railroad
- UPRR** = Union Pacific Railroad
- USDOT** = United States Department of Transportation



Appendix A Quick Reference Sheet

UP Public Projects – Quick Reference Links

Company Mailing Address and Phone	Union Pacific Railroad 1400 Douglas Street Omaha, NE 68179 402-544-5000 or 888-870-8777
Reporting Unusual or Suspicious Occurrences and Environmental Hazards	Please call 1-888-UPRR COP (877-7267) to report hazardous materials releases, personal injuries, criminal activities, illegal dumping, or other environmental incidents.
Reporting Rough or Damaged Grade Crossings	Please call 1-800-848-8715 to report emergency grade crossing blockages or damage.
Fiber Optic Cable	Call the Railroad's Fiber Optic Hotline at 1-800-336-9193 (a 24-hour number) to determine if fiber optic cable is buried anywhere on the Railroad's property. Notification is required at least 48 hours prior to start of construction.

Submitting a Public Project (Roadway, Bridge, or Path)

Please submit your information to the link below to get the process started or if you have an inquiry.

<https://benesch.quickbase.com/db/bpqhu6hqy?a=dbpage&pageid=13>

When making an inquiry, submittal or responding to UPRR, ensure that the following information is in all email subject lines and on ALL documents (memos, reports, plans, liability insurance, etc):

"Project type, % Plans, City, State, Street, Milepost, Subdivision, DOT# and Lat/Long"

Public Projects Check Sheet:

https://www.up.com/cs/groups/public/@uprr/@customers/@industrialdevelopment/@operationsspecs/@specifications/documents/up_pdf_nativedocs/pdf_up_pub_checklist.pdf

Community Public Affairs Contacts

https://www.up.com/aboutup/community/community_contacts/index.htm

Public Safety Information:

<http://www.upcares.com>

eRailSafe Site:

<https://www.up.com/aboutup/community/safety/erailsafe/index.htm>

Public Project Links

Public Project Information:

http://www.up.com/real_estate/roadxing/industry/index.htm

IPP Reimbursement Agreement (RA):

https://www.up.com/cs/groups/public/@uprr/@realestate/documents/up_pdf_nativedocs/pdf_up_quiet_prelim.pdf Contractor Safety Requirements:
<http://www.up.com/suppliers/contractor-safety/index.htm>

Real Estate / Permit of Non-intrusive Survey:

https://www.up.com/cs/groups/public/@uprr/@realestate/documents/up_pdf_nativedocs/pdf_up_reus_rrpermit.pdf

Real Estate/Utility Installation Information:

http://www.up.com/real_estate/utilities/index.htm

Real Estate / Right of Entry / Temporary Use of Railroad Application:

http://www.up.com/real_estate/tempuse/index.htm

Real Estate / Right of Entry / Road Crossing Construction:

https://www.up.com/cs/groups/public/@uprr/@realestate/documents/up_pdf_nativedocs/up_pdf_croe_app_of_road_proj.pdf

Real Estate / Road Crossing Agreement Form (Existing or New):

https://www.up.com/cs/groups/public/@uprr/@realestate/documents/up_pdf_nativedocs/pdf_up_reus_roadxing_form.pdf

Real Estate / Property & Track Ownership Research:

https://www.up.com/real_estate/PropertyOwnership/index.htm

Technical Specifications for Construction of Industrial Tracks:

<http://www.uprr.com/aboutup/operations/specs/track/index.shtml>

Grade Separation Bridge Projects:

https://www.up.com/real_estate/roadxing/industry/grade_separation/index.htm

Guidelines for Temporary Shoring:

https://www.up.com/cs/groups/public/@uprr/@customers/@industrialdevelopment/@operationsspecs/@specifications/documents/up_pdf_nativedocs/pdf_up_str_temp-shoring.pdf

Demolition Guidelines:

https://www.up.com/cs/groups/public/@uprr/@realestate/documents/up_pdf_nativedocs/pdf_up_reus_industry_demo.pdf

Wireline and Pipeline Crossing Application (Utility Contracts System):

<https://www.uprr.com/rem/ucs/jas/#/home>

New At-Grade Crossing Request:

https://www.up.com/real_estate/roadxing/procedures/index.htm

Joint UP-BNSF Guidelines for Railroad Grade Separation Projects:

https://www.up.com/cs/groups/public/documents/document/pdf_rr_grade_sep_projects.pdf



Appendix B Contact Center Inquiry Submission Form

INQUIRY SUBMISSION FORM:

Contact Information is for the Agency/Individual Responsible for the Inquiry



Contact Information

Requestor Type *

Agency / Company Name *

First Name * Last Name *

Street City State Zip Code

Phone Number * ext. Mobile Number

Email *

DOT Number is Preferred to Identify Project Location. The DOT Number can be Found by Accessing the Federal Railroad



<https://safetydata.fra.dot.gov/OfficeofSafety/PublicSite/Crossing/Crossing.aspx>

Or at the Location of the Crossing:

Project Location

DOT # (ex. #####X or 430346N) GPS Lat (ex. 35.954133) GPS Long (ex. -101.932343)

Street City State

Location Description *

Provide Address of Project Location



REPORT EMERGENCY OR PROBLEM TO 1-800-555-5555 CROSSING 836 597 H

DOT 836597H

Complete this field for project locations that do not have a DOT or GPS Lat/Long

Provide a Location Description in Proximity to Railroad Tracks or Nearest Railroad Crossing

Project Description

Project Type * Estimated Project Cost

Project Description *

Briefly describe the Project and How Union Pacific Railroad is Affected

Upload Maps, Plans, Photographs, Applications, Requests, Agreements, etc.

Document Upload

Choose Files

If needed, please add any documents prior to saving this form.

Save



Requestor Type *



A dropdown menu for 'Requestor Type' with a list of options. The top bar is blue. A mouse cursor is pointing at the top right corner of the menu.

- Citizen
- Consultant
- Contractor
- Developer
- Government
- Industry
- Other
- Railroad
- Road Authority
- UPRR Customer

Project Description

Project Type *

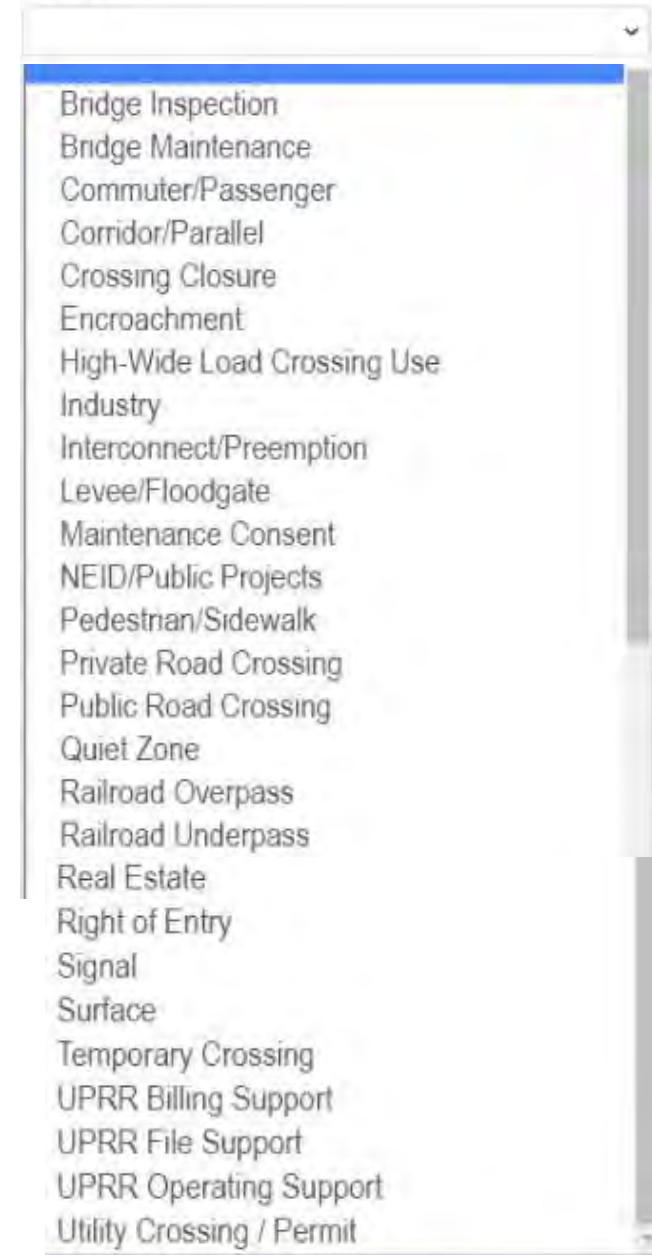

A dropdown menu for 'Project Type' with a list of options. The top bar is blue. A scroll bar is visible on the right side of the menu.

- Bridge Inspection
- Bridge Maintenance
- Commuter/Passenger
- Corridor/Parallel
- Crossing Closure
- Encroachment
- High-Wide Load Crossing Use
- Industry
- Interconnect/Preemption
- Levee/Floodgate
- Maintenance Consent
- NEID/Public Projects
- Pedestrian/Sidewalk
- Private Road Crossing
- Public Road Crossing
- Quiet Zone
- Railroad Overpass
- Railroad Underpass
- Real Estate
- Right of Entry
- Signal
- Surface
- Temporary Crossing
- UPRR Billing Support
- UPRR File Support
- UPRR Operating Support
- Utility Crossing / Permit



Appendix C Design Review Comment Tracking Spreadsheet



DESIGN & PLAN REVIEW COMMENTS

Check for compliance with current AREMA and UPRR guidelines

It should be noted that this review of the construction documents does not relieve the sponsoring agency or their consultant from ultimate responsibility and liability for the construction documents as the Engineer-of-Record nor from liability for damages to UPRR property during and after construction of the project.

Project Name:		Submittal Description:			
UPRR Milepost:	Subdivision:	City:	State:	Roadway:	
Agency/Owner:	Contact:	Designer:		Contact:	
CPUC:	UP MIPP:	Reviewer 2:		Reviewer 3:	

Special Notes: Please respond to comments below and then forward this document with updated copies of the plans for the next submittal.

Item No.	Sheet No.	Reviewer Comment <small>Date:</small>	Initial	Designer's Response <small>Date:</small>	Reviewer's Comment <small>Date:</small>	Initial	Designer's Response <small>Date:</small>	Reviewer's Comment <small>Date:</small>	Initial	Status (Open or Closed)
1.										
2.										
3.										
4.										
5.										
6.										
7.										
8.										
9.										
10.										
11.										
12.										
13.										
14.										
15.										
16.										
17.										
18.										
19.										
20.										
21.										
Add Row		Delete Last Row								



Appendix D Crossing Diagnostic Items and Form



UPRR Diagnostic Review Process

Locational Data:

Street Name: _____

City: _____

Railroad Subdivision: _____

DOT Crossing Number: _____

Milepost: _____

Define the scope and purpose of the work:

Is the crossing skewed? ___ Y ___ N

What is the angle of intersection? _____

Roadway width/lane widths: _____

Number of lanes: _____

Curb type and location: _____

Approach pavement material and limits: _____

Driveway locations: _____

Median location and dimensions (non-mountable curb?): _____

Parking or turn lane locations: _____

Profile grades and breaks: _____

Sidewalk locations, width, slope, condition: _____

Will the track need to be raised? ___ Y ___ N

Is the track in super-elevation? ___ Y ___ N

Is the roadway in super-elevation? ___ Y ___ N

Is the track & roadway surface at a uniform plane? ___ Y ___ N

Is there a parallel street? How far is it from the warning devices? ___ Y ___ N

What is the existing roadway classification? _____

Any roadside safety issues? Check clear zone slopes. _____



UPRR Diagnostic Review Process

Visibility (Do the trees or brush need to be trimmed?) _____

Existing Drainage (Is the runoff training towards the track?) _____

Are there soil or geotechnical issues? ___ Y ___ N _____

Does the ballast look clean? ___ Y ___ N _____

Is there ponding within UP ROW? ___ Y ___ N _____

Do any inlets or pipes need to be cleaned out? ___ Y ___ N _____

Is there a pipe for RR ditch conveyance? ___ Y ___ N _____

Does the cross pipe have the appropriate end sections? ___ Y ___ N _____

Is there evidence of erosion? ___ Y ___ N _____

Existing Crossing Surface/Planking type and size:

Number of tracks: _____

Distance between adjacent track: _____

Mainline or siding track? _____

Existing Warning Devices:

Distances from device pole's centerline to travel lane and near rail. _____

Location and distance of signal bungalow or controller from track near rail and roadway travel lane.

Side lights? ___ Y ___ N

Type of devices – are they out dated? _____

ENS sign present? ___ Y ___ N

How are pedestrians handled? _____

Utility conflicts at new device locations? _____

Existing utility crossings that might not meet UP criteria for overhead clearance or underground casing limits. _____

Existing traffic signal interconnect? ___ Y ___ N _____

Existing Pre-Emption warning time? ___ Y ___ N _____

Location of existing traffic signal control box? _____



UPRR Diagnostic Review Process

Existing train traffic and speed: _____

Fencing – existing and proposed: _____

Proposed roadway changes (number of lanes, widths, median, sidewalk, profile, etc.) _____

Will the new profile meet AASHTO and State Agency (PUC) requirements? ___ Y ___ N

Proposed Warning Devices Recommended:

What are the UP signal impacts from changes to the roadway? _____

Will a new signal bungalow be required? ___ Y ___ N _____

What quadrant should a new signal bungalow be placed? _____

Is there room for the UP access drive to the signal bungalow? Review the UP grading requirements.

Are side lights needed? ___ Y ___ N _____

Will the signal placement require other horizontal or vertical roadway changes? ___ Y ___ N _____

Placement of devices on skewed crossings might need to be set further away due to light hood fixture and signal mounting arm. _____

Confirm gate placement requirement – perpendicular to roadway or parallel to track? _____

Confirm power source _____

Is lighting needed? ___ Y ___ N _____

Pedestrians and Bicycle Accommodations

What are the existing widths and condition of sidewalks or pathways? _____

How far from the track does the sidewalk or path concrete material end? _____

Is there sufficient track surface past the sidewalk or path? (should extend 3' past) ___ Y ___ N

Proposed bicycle route incorporation? _____

Is the street within the local bicycle network? ___ Y ___ N _____



UPRR Diagnostic Review Process

Note any bicyclist or pedestrian using the crossing during the diagnostic meeting:

What are the pedestrian or cyclist traffic generators? _____

Do pedestrian channelizing features need to be added to the project? ___ Y ___ N _____

Grade Separation

Vertical Clearance – from top of rail horizontally to a 9’ offset either side of track centerline to the low chord of the bridge over RR. _____

Horizontal clearance – from existing near rail and future track near rail to pier obstruction: _____

Planned Phasing: _____

Right of Way

Roadway Approach Right of way: _____

Railroad Right of Way – overall width and distance from track centerline: _____

Is there an existing Agreement at crossing? ___ Y ___ N _____

What is the Agreement Folder Number? _____

Traffic

Are there streets, driveways or businesses within 200’ of the crossing? ___ Y ___ N _____

Does the traffic queue into the UP ROW or across the track? ___ Y ___ N _____

Will a new traffic signal interconnect be warranted? ___ Y ___ N _____

What other traffic queuing solutions are there? _____

Are there any bus stops, parking or other queuing sources nearby? ___ Y ___

When the crossing is closed for construction, what would be the likely detour? _____



UPRR Diagnostic Review Process

What is the peak hour traffic? _____

What is the peak seasonal traffic or special events that generate heavier traffic? _____

Is further traffic analysis or study needed? Y N _____

Photographs and Plan Markups

- Take photos at the crossing in each direction, including the roadway approaches.
- Do not stand on track to take photos.
- Take photos of all pertinent information gathered during the diagnostic.
- Mark notes on the Concept plan to be included in the meeting notes and distributed to all the attendees.

Do the sidewalks meet ADA requirements? Y N _____

Proposed roadway criteria to be used: _____

Design Vehicle and roadway design speed and existing posted speed: _____

Funding

What items will be eligible for federal or state reimbursement? _____

RR cost participation? Y N _____

List which items will be constructed by UP Force Account. _____

How will inspections be performed during construction? _____

How will invoices be reviewed and approved? _____



Appendix E Guidance for Sidewalk Improvements

ITEM	DESCRIPTION
1	VEHICULAR DEVICE WITH GATE ARM. STANDARD: MUTCD 8C.02 & 8C.04
2	MIN. 2' DETECTABLE WARNING STRIP. STANDARD: MUTCD 8D.04
3	MIN. 3' FROM EDGE OF TRAVELED WAY INCLUDING SHOULDERS OR SIDEWALKS. STANDARD: UP STD DWG 0304
4	24" STOP LINE - 8' IN ADVANCE OF NEAREST RAILROAD TRAFFIC CONTROL DEVICE. STANDARD: MUTCD 3B-16
5	MIN. 24" STRIP OF ASPHALT BETWEEN CROSSING SURFACE AND ROADWAY. STANDARD: UP STD DWG 0304
6	UNPAVED AREA - E.G. AGGREGATE MATERIAL AROUND DEVICES FOR MAINTENANCE ACCESS. GUIDANCE: UP MAINTENANCE
7	MIN. 10' FROM CENTER OF TRACK, TAPERED CURB. GUIDANCE: STANDARD PRACTICE
8	8" NON-MOUNTABLE RAISED CURB. STANDARD: MUTCD 8C-01
9	MOUNTABLE CURB FOR MAINTENANCE ACCESS. GUIDANCE: UP MAINTENANCE

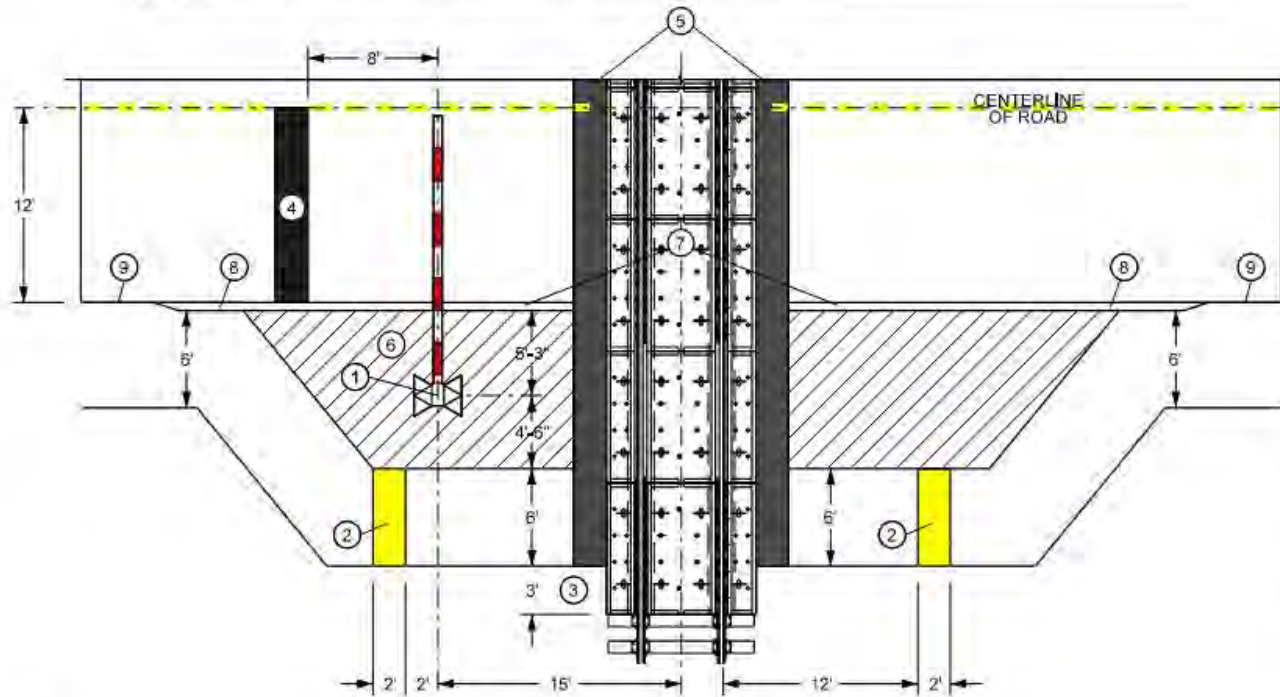

GUIDANCE FOR SIDEWALK IMPROVEMENTS

- NOTES:
1. THE PURPOSE OF THIS DOCUMENT IS TO PROVIDE THE DESIGN ENGINEER WITH THE GUIDELINES FOR SIDEWALK IMPROVEMENTS.
 2. THIS DOCUMENT DOES NOT SUBSTITUTE THE DESIGN ENGINEER'S SPECIFICATIONS FOR A SPECIFIC PROJECT, BUT PROVIDES THE BASIS OF THE STANDARDS, WHICH THE DESIGN ENGINEER SHALL FOLLOW.

UNION PACIFIC RAILROAD ENGINEERING STANDARDS	
GUIDANCE FOR SIDEWALK IMPROVEMENTS	
 APPROVED: _____ VP ENGINEERING ADOPTED: JUNE 3, 2020 REVISED: _____ FILE NO.: XXXX	STD DWG XXXX PAGE 1 OF 3

Copyright © 2020 by Union Pacific Railroad

STD DWG
 XXXX
 PAGE 1 OF 3

ITEM	DESCRIPTION
1	VEHICULAR DEVICE WITH GATE ARM, STANDARD; MUTCD 8C.02 & 8C.04
2	PEDESTRIAN DEVICE, STANDARD; MUTCD 8D.06
3	MIN. 2' DETECTABLE WARNING STRIP, STANDARD; MUTCD 8D.04
4	MIN. 3' FROM EDGE OF TRAVELED WAY INCLUDING SHOULDERS OR SIDEWALKS, STANDARD; UP STD DWG 0304
5	24" STOP LINE - 8' IN ADVANCE OF NEAREST RAILROAD TRAFFIC CONTROL DEVICE, STANDARD; MUTCD 3B-16
6	MIN. 24" STRIP OF ASPHALT BETWEEN CROSSING SURFACE AND ROADWAY, STANDARD; UP STD DWG 0304
7	UNPAVED AREA - E.G. AGGREGATE MATERIAL AROUND DEVICES FOR MAINTENANCE ACCESS, GUIDANCE; UP MAINTENANCE
8	MIN. 10' FROM CENTER OF TRACK, TAPERED CURB, GUIDANCE; STANDARD PRACTICE
9	6" NON-MOUNTABLE RAISED CURB, STANDARD; MUTCD 8C-01
10	MOUNTABLE CURB FOR MAINTENANCE ACCESS, GUIDANCE; UP MAINTENANCE

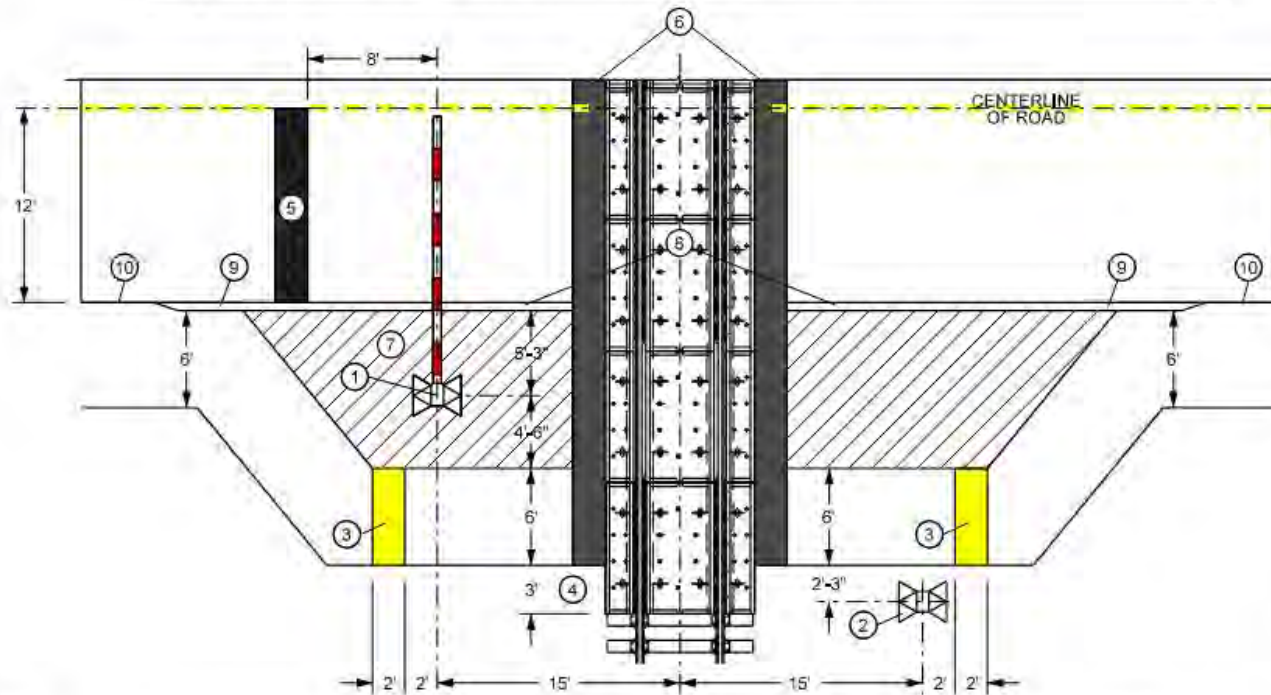

GUIDANCE FOR SIDEWALK IMPROVEMENTS W/ OFF-QUADRANT PEDESTRIAN DEVICE

- NOTES:
1. THE PURPOSE OF THIS DOCUMENT IS TO PROVIDE THE DESIGN ENGINEER WITH THE GUIDELINES FOR SIDEWALK IMPROVEMENTS W/ OFF-QUADRANT PEDESTRIAN DEVICE.
 2. THIS DOCUMENT DOES NOT SUBSTITUTE THE DESIGN ENGINEER'S SPECIFICATIONS FOR A SPECIFIC PROJECT, BUT PROVIDES THE BASIS OF THE STANDARDS, WHICH THE DESIGN ENGINEER SHALL FOLLOW.

UNION PACIFIC RAILROAD ENGINEERING STANDARDS	
GUIDANCE FOR SIDEWALK IMPROVEMENTS	
 APPROVED: _____ VP ENGINEERING ADOPTED: JUNE 3, 2020 REVISED: FILE NO.: XXXX	STD DWG XXXX PAGE 2 OF 3

Copyright © 2020 by Union Pacific Railroad

STD DWG
 XXXX
 PAGE 2 OF 3

ITEM	DESCRIPTION
1	VEHICULAR DEVICE WITH GATE ARM. STANDARD: MUTCD 8C.02 & 8C.04
2	PEDESTRIAN DEVICE WITH GATE ARM. STANDARD: MUTCD 8D.06
3	PEDESTRIAN EMERGENCY EXIT GATE. GUIDANCE: STANDARD PRACTICE
4	PEDESTRIAN CHANNELIZING DEVICE - E.G. STEEL TUBE RAIL. INSTALLED NO CLOSER THAN 12' TO CL. GUIDANCE: UP OPERATION AND MAINTENANCE
5	MIN. 2' DETECTABLE WARNING STRIP. STANDARD: MUTCD 8D.04
6	MIN. 3' FROM EDGE OF TRAVELED WAY INCLUDING SHOULDERS OR SIDEWALKS. STANDARD: UP STD DWG 0304
7	24" STOP LINE - 8' IN ADVANCE OF NEAREST RAILROAD TRAFFIC CONTROL DEVICE. STANDARD: MUTCD 3B-16
8	GATE TO PROVIDE UPRR VEHICLE ACCESS FOR MAINTENANCE. STANDARD: UP STD DWG 0076
9	24" MIN. STRIP OF ASPHALT BETWEEN CROSSING SURFACE AND ROADWAY. STANDARD: UP STD DWG 0304
10	UNPAVED AREA - E.G. AGGREGATE MATERIAL AROUND DEVICES FOR MAINTENANCE ACCESS. GUIDANCE: UP MAINTENANCE
11	MIN. 10' FROM CENTER OF TRACK, TAPERED CURB. GUIDANCE: STANDARD PRACTICE
12	6" NON-MOUNTABLE RAISED CURB. STANDARD: MUTCD 8C-01
13	MOUNTABLE CURB FOR MAINTENANCE ACCESS. GUIDANCE: UP MAINTENANCE

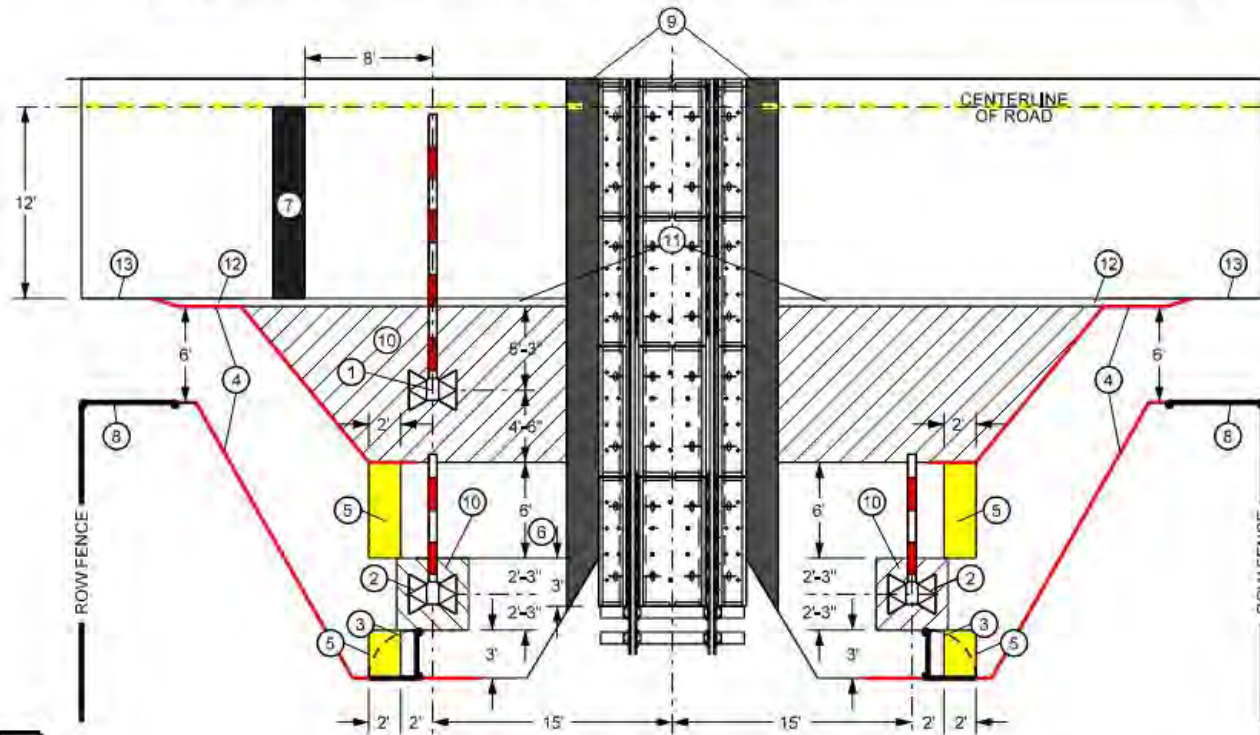

GUIDANCE FOR SIDEWALK IMPROVEMENTS W/ PEDESTRIAN GATES

- NOTES:
1. THE PURPOSE OF THIS DOCUMENT IS TO PROVIDE THE DESIGN ENGINEER WITH THE GUIDELINES FOR SIDEWALK IMPROVEMENTS W/ GATE ARMS AND EMERGENCY EXIT ROUTES.
 2. THIS DOCUMENT DOES NOT SUBSTITUTE THE DESIGN ENGINEER'S SPECIFICATIONS FOR A SPECIFIC PROJECT, BUT PROVIDES THE BASIS OF THE STANDARDS, WHICH THE DESIGN ENGINEER SHALL FOLLOW.

**UNION PACIFIC RAILROAD
ENGINEERING STANDARDS**

**GUIDANCE FOR
SIDEWALK
IMPROVEMENTS**



APPROVED: VP ENGINEERING
ADOPTED: JUNE 3, 2020
REVISED:
FILE NO.: XXXX

STD DWG
XXXX
PAGE 3 OF 3

Copyright © 2020 by Union Pacific Railroad

STD DWG
XXXX
PAGE 3 OF 3



Appendix F Sample Grade Crossing Plan Sheet RURAL

ROAD AUTHORITY OR CONTRACTOR

- 1 CONSTRUCT 4" SOLID WHITE
- 2 CONSTRUCT 4" SOLID YELLOW
- 3 CONSTRUCT 24" SOLID WHITE
- 4 CONSTRUCT RAILROAD MARKING SYMBOL
- 5 CONSTRUCT 4" SOLID YELLOW (DOUBLE)

UPRR

- A UPRR TO CONSTRUCT SIGNAL FLASHING LIGHT GATE AND FOUNDATION 15' FROM CENTERLINE OF TRACK. PROVIDE GATE ARM LENGTH FOR CENTER OF MAST TO CENTERLINE OF ROADWAY DISTANCE 21'.
- B UPRR TO CONSTRUCT SIGNAL FLASHING LIGHT GATE AND FOUNDATION 15' FROM CENTERLINE OF TRACK. PROVIDE GATE ARM LENGTH FOR CENTER OF MAST TO CENTERLINE OF ROADWAY DISTANCE 21'.

1. ALL SIGNING, PAVEMENT MARKINGS, TRAFFIC SIGNALS AND TRAFFIC SIGNAL APPURTENANCES SHALL BE CONSTRUCTED / INSTALLED IN ACCORDANCE WITH THE LATEST EDITION OF THE (STATE) MANUAL OF UNIFORM TRAFFIC CONTROL DEVICES (MUTCD) & STANDARD DRAWINGS.
2. ALL ROADWAY SIGNS PLACED IN ADVANCE OF THE CROSSING SIGNALS ARE TO BE PLACED SUCH THAT THEY DO NOT OBSTRUCT THE MOTORIST'S VIEW OF THE SIGNALS.
3. ALL SIGNS PLACED IN ADVANCE OF RAILROAD WARNING DEVICES SHALL BE A MINIMUM OF 12' FROM EDGE OF PAVEMENT OR MINIMUM OF 10' FROM FACE OF CURB. IF SIDEWALK IS PRESENT SIGNS SHOULD BE A MINIMUM OF 3' FROM INSIDE EDGE OF SIDEWALK TO EDGE OF SIGN, WHERE FEASIBLE.
4. UTILITY LOCATIONS, OWNERSHIP AND PROPOSED ROADWAY/ TRACK WORK TO BE COORDINATED WITH JOINT UTILITY LOCATION INFORMATION FOR EXCAVATORS PUBLIC ROAD AUTHORITY ONE CALL AND U.P.R.R. PRIOR TO CONSTRUCTION.

5. LOCATIONS OF OVERHEAD AND UNDERGROUND UTILITIES ARE APPROXIMATE AND MUST BE FIELD VERIFIED PRIOR TO SIGN PLACEMENT.
6. ALL RAILROAD ADVANCE WARNING SIGNS SHALL BE DIAMOND GRADE REFLECTIVITY.
7. ALL PROPOSED SIGNS SHALL HAVE TELESCOPING METAL SIGN SUPPORTS. ALL POSTS ARE TO BE INSTALLED PER PUBLIC ROAD AUTHORITY DOT STANDARD. SIGN POSTS MUST BE BREAK AWAY TYPE WITH BREAK AWAY ANCHORS.
8. ROAD AUTHORITY OR CONTRACTOR TO CLEAR ALL TREE LIMBS AND BRUSH TO PROVIDE VISIBILITY FOR ALL NEW SIGNS AND EXISTING SIGNS TO REMAIN WITHIN THE PROJECT LIMITS.

CLOSURES REQUIRED
FULL CLOSURE FOR ROADWAY WORK W/ DETOUR.

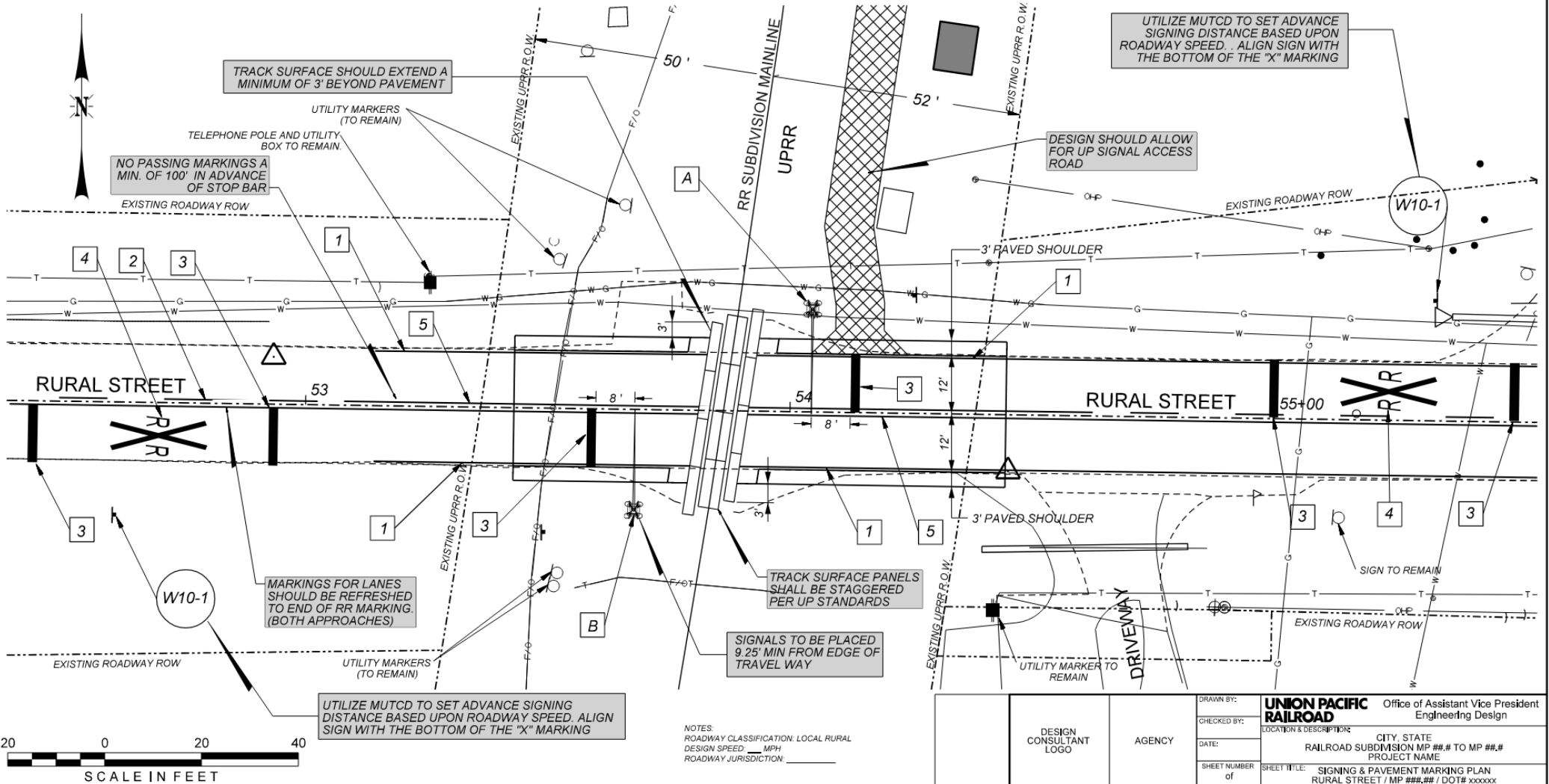

Color Tables: \\comtr-ar-v1\VECCGADS\standards\UPRR\Tables\Color\UPRR.tbl
 Pen Tables: \\comtr-ar-v1\VECCGADS\standards\UPRR\Tables\Pen\UPRR.tbl
 File Name: pwr://HDR_US_National.01/4195/10185707/RURAL_CROSSING_2.dgn
 Plot Date: 5/28/2021 8:30:27 AM
 Plot Time: 8:30:27 AM
 PLOTED:



NOTES:
ROADWAY CLASSIFICATION: LOCAL RURAL
DESIGN SPEED: _____ MPH
ROADWAY JURISDICTION: _____

DESIGN CONSULTANT LOGO	AGENCY	DRAWN BY:	UNION PACIFIC RAILROAD	Office of Assistant Vice President Engineering Design
		CHECKED BY:	LOCATION & DESCRIPTION	
		DATE:	CITY, STATE	
		SHEET NUMBER of	RAILROAD SUBDIVISION MP ### TO MP ### PROJECT NAME	
			SHEET TITLE: SIGNING & PAVEMENT MARKING PLAN RURAL STREET / MP ###,### / DOT# xxxxxx	

pwr://HDR_US_National.01/4195/10185707/RURAL_CROSSING_2.dgn



Appendix G Sample Grade Crossing Plan Sheet URBAN

Color Table:
 File Name: \\snp\proj\1\EGC\085\...
 Model: BRINT_DELIVER_SPL_TDRVL\$
 PRINTED: 6/28/2024 8:24 AM 5:02 PM

LIST OF PERMANENT ROADWAY SIGNING & MARKINGS

ITEM	DOT / MUTCD	SIZE	CONTRACTOR QTY.
STOP SIGN	R1-1	36" X 36"	
NO LEFT TURN	R3-2	24" X 24"	
ONE WAY RIGHT IN ARROW	R6-1R	36" X 12"	
RAILROAD CROSSING SIGN	W10-1	30" DIA	
RAILROAD CROSSING SIGN RIGHT	W10-4	36" X 36"	
TRAINS MAY EXCEED 80 MPH SIGN	W10-8	36" X 36"	
REMOVE SIGN	W10-1	30" DIA	
LETTERS AND SYMBOL (RXR)			
8" YELLOW			
24" WHITE			
4" YELLOW (DOUBLE)			

- CONTRACTOR**
- 4" SOLID WHITE (TO REMAIN)
 - CONSTRUCT 4" SOLID YELLOW (DOUBLE)
 - CONSTRUCT 24" SOLID WHITE
 - 4" SKIP DASH WHITE (30'-10') (TO REMAIN)
 - LETTERS AND SYMBOLS (TO REMAIN)
 - CONSTRUCT RAILROAD MARKING SYMBOL
 - CONSTRUCT 8" SOLID YELLOW
 - REMOVE EXISTING MARKINGS
 - BEGIN 4" SOLID DOUBLE YELLOW
 - PROPOSED 'X' SIGNAL BUNGALOW. COORDINATE LOCATION WITH UPRR SIGNAL. CONTRACTOR TO PROVIDE GRADING FOR SIGNAL PAD, OFFSET 40' FROM EDGE OF TRAVEL LANE & 30' FROM NEAR RAIL. (MAY DEPEND UPON SKEW OF CROSSING)

- NOTES:**
- ALL SIGNING, PAVEMENT MARKINGS, TRAFFIC SIGNALS AND TRAFFIC SIGNAL APPURTENANCES SHALL BE CONSTRUCTED/INSTALLED IN ACCORDANCE WITH THE LATEST EDITION OF THE MANUAL OF UNIFORM TRAFFIC CONTROL DEVICES (MUTCD) AND STATE HIGHWAY STANDARDS.
 - ALL ROADWAY SIGNS PLACED ON URBAN STREET IN ADVANCE OF THE CROSSING SIGNALS ARE TO BE PLACED SUCH THAT THEY DO NOT OBSTRUCT THE MOTORIST'S VIEW OF THE SIGNALS.
 - ALL SIGNS PLACED IN ADVANCE OF RAILROAD WARNING DEVICES SHALL BE A MINIMUM OF 12' FROM EDGE OF PAVEMENT OR MINIMUM OF 10' FROM FACE OF CURB. IF SIDEWALK IS PRESENT SIGNS SHOULD BE A MINIMUM OF 3' FROM INSIDE EDGE OF SIDEWALK TO EDGE OF SIGN, WHERE FEASIBLE.
 - UTILITY LOCATIONS, OWNERSHIP AND PROPOSED ROADWAY/ TRACK WORK TO BE COORDINATED WITH JOINT UTILITY LOCATION INFORMATION FOR EXCAVATORS UTILITY ONE CALL AND U.P.R.R. PRIOR TO CONSTRUCTION.
 - LOCATIONS OF OVERHEAD AND UNDERGROUND UTILITIES ARE APPROXIMATE AND MUST BE FIELD VERIFIED PRIOR TO SIGN PLACEMENT.
 - ALL RAILROAD ADVANCE WARNING SIGNS SHALL BE DIAMOND GRADE REFLECTIVITY.
 - CONTRACTOR TO CLEAR ALL TREE LIMBS AND BRUSH TO PROVIDE VISIBILITY FOR ALL NEW SIGNS AND EXISTING SIGNS TO REMAIN WITHIN THE PROJECT LIMITS.
 - REFER TO PUBLIC ROAD AUTHORITY STANDARDS.

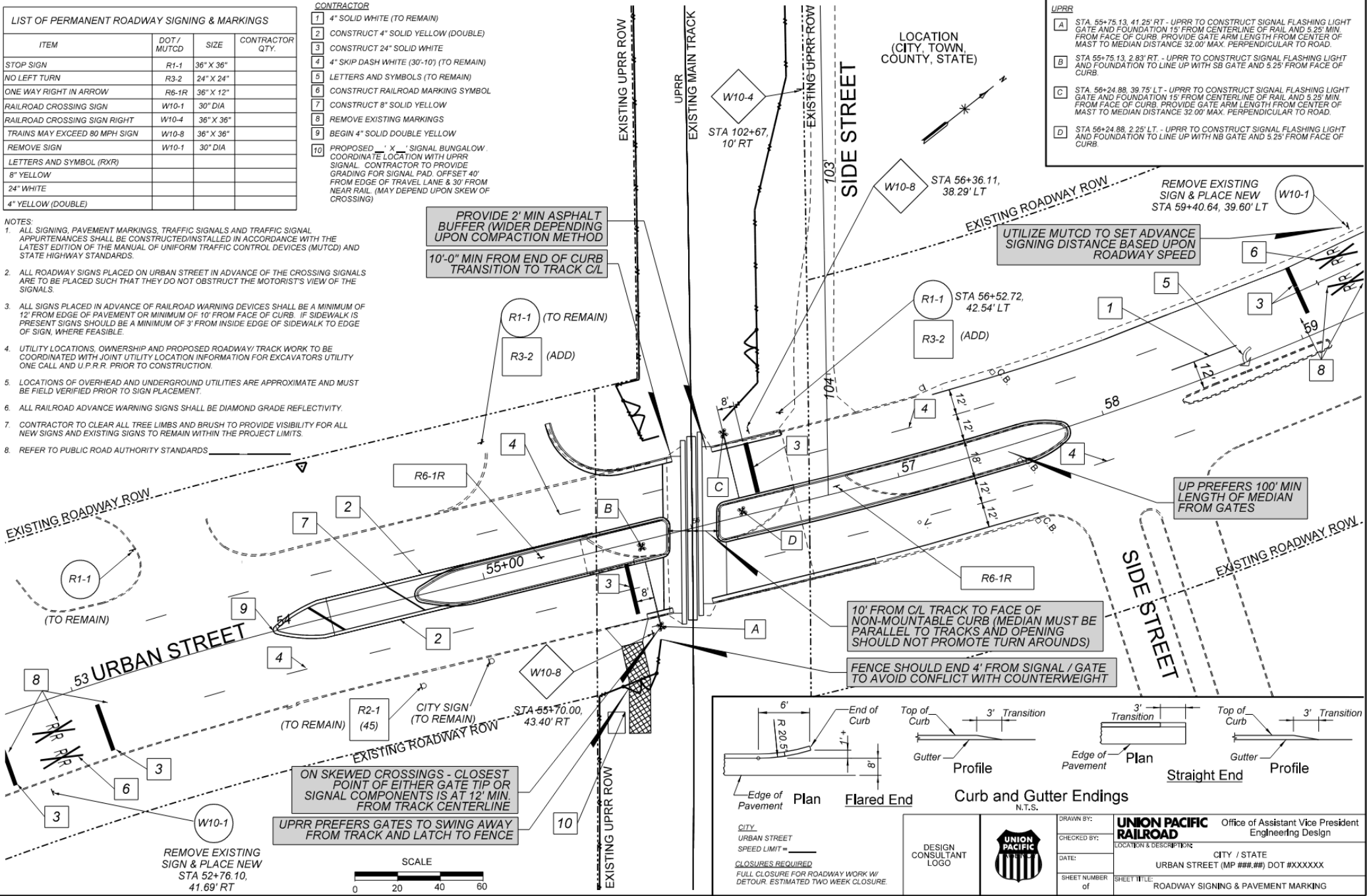

- UPRR**
- STA 55+75.13, 41.25' RT - UPRR TO CONSTRUCT SIGNAL FLASHING LIGHT GATE AND FOUNDATION 15' FROM CENTERLINE OF RAIL AND 5.25' MIN. FROM FACE OF CURB. PROVIDE GATE ARM LENGTH FROM CENTER OF MAST TO MEDIAN DISTANCE 32.00' MAX. PERPENDICULAR TO ROAD.
 - STA 56+75.13, 2.83' RT - UPRR TO CONSTRUCT SIGNAL FLASHING LIGHT AND FOUNDATION TO LINE UP WITH SB GATE AND 5.25' FROM FACE OF CURB.
 - STA 56+24.88, 39.75' LT - UPRR TO CONSTRUCT SIGNAL FLASHING LIGHT GATE AND FOUNDATION 15' FROM CENTERLINE OF RAIL AND 5.25' MIN. FROM FACE OF CURB. PROVIDE GATE ARM LENGTH FROM CENTER OF MAST TO MEDIAN DISTANCE 32.00' MAX. PERPENDICULAR TO ROAD.
 - STA 56+24.88, 2.25' LT - UPRR TO CONSTRUCT SIGNAL FLASHING LIGHT AND FOUNDATION TO LINE UP WITH NB GATE AND 5.25' FROM FACE OF CURB.

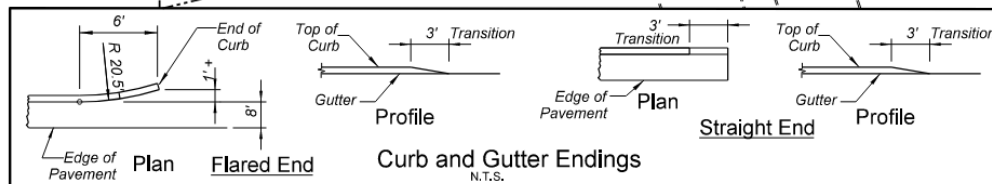

DESIGN CONSULTANT LOGO

UNION PACIFIC RAILROAD

Office of Assistant Vice President Engineering Design

CITY / STATE: _____

URBAN STREET (MP ###.##) DOT #XXXXXX

ROADWAY SIGNING & PAVEMENT MARKING



Appendix H Structure Site Selection Report Guidelines

UPRR Public Projects Design Review – Type Selection Report

Type Selection Report	
The type selection report should include exhaustive alternatives analysis/design which:	
A	i) Preferably does not utilize the UPRR right-of-way or ii) Uses as little of the right-of-way as possible.
B	Does not limit UPRR’s ability to Protect and Preserve the UPRR right-of-way. See below.
C	Are vetted by not only considering cost of the project.

UPRR’s Position on Accommodations for 3rd Party Projects within UPRR Right-of-Way		
PROTECT	Projects shall be designed such that construction activities and phasing will not compromise safety nor impact UPRR operations.	
PRESERVE	Projects shall be designed such that they A) inherently provide UPRR the ability to expand, B) do not impede expansion, C) do not increase the cost or burden to UPRR for later expansion and D) remove any existing unnecessary burdens to UPRR.	
	A	Projects shall inherently provide ability, via the project’s structures or otherwise, to provide future tracks, access roads, drainage facilities and other infrastructure as deemed necessary by UPRR which meet or exceed UPRR requirements.
	B	Projects shall not impede nor limit UPRR ability to expand and construct future tracks, access roads, drainage facilities and other infrastructure as deemed necessary by UPRR which meet or exceed UPRR requirements.
	C	Projects shall not increase expense nor burden to UPRR to later (i) construct future tracks, access roads, drainage facilities and other infrastructure as deemed necessary by UPRR which meet or exceed UPRR requirements nor to (ii) maintain, inspect and replace rail infrastructure.
	D	Projects shall remove existing unnecessary burdens to UPRR.



Appendix I Bridge Ownership and Maintenance

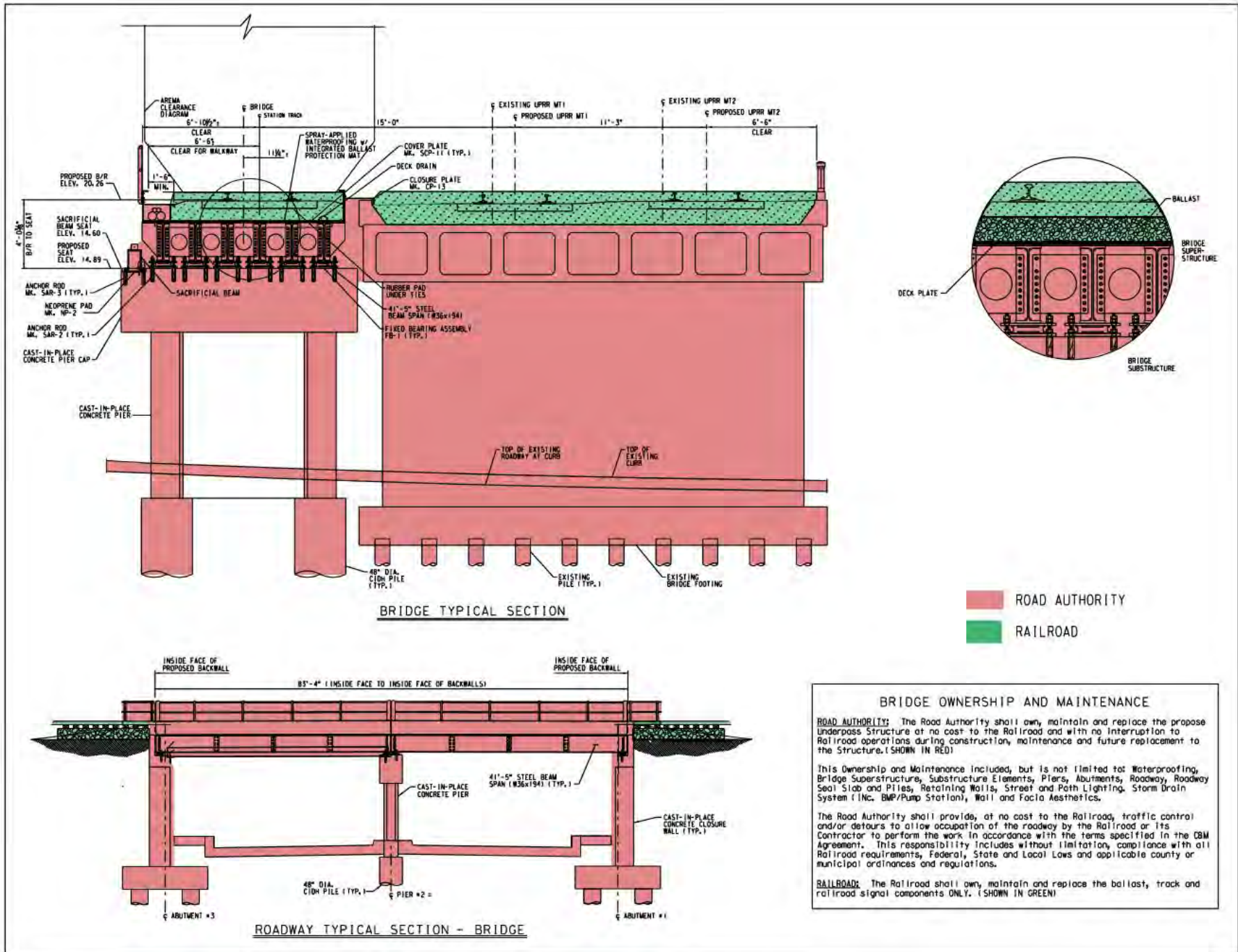



Appendix J Sample Parallel Encroachment Sheet

Color: tables\DMTRSRV1\EGC\CADStandards\UPRR\TRATables\Color\UPRR.tbl
 \\DMTRSRV1\EGC\CADStandards\UPRR\TRV\8\HRR\UPRR_V8.pentable.tbl
 P:\495\1018570\6.0.CAD_BIM\6.2.WP.Files For examples\PARALLEL ROAD ENCROACHMENT EXAMPLE\PARALLEL ROAD ENCROACHMENT.dgn
 1/23/2020 3:25:22PM

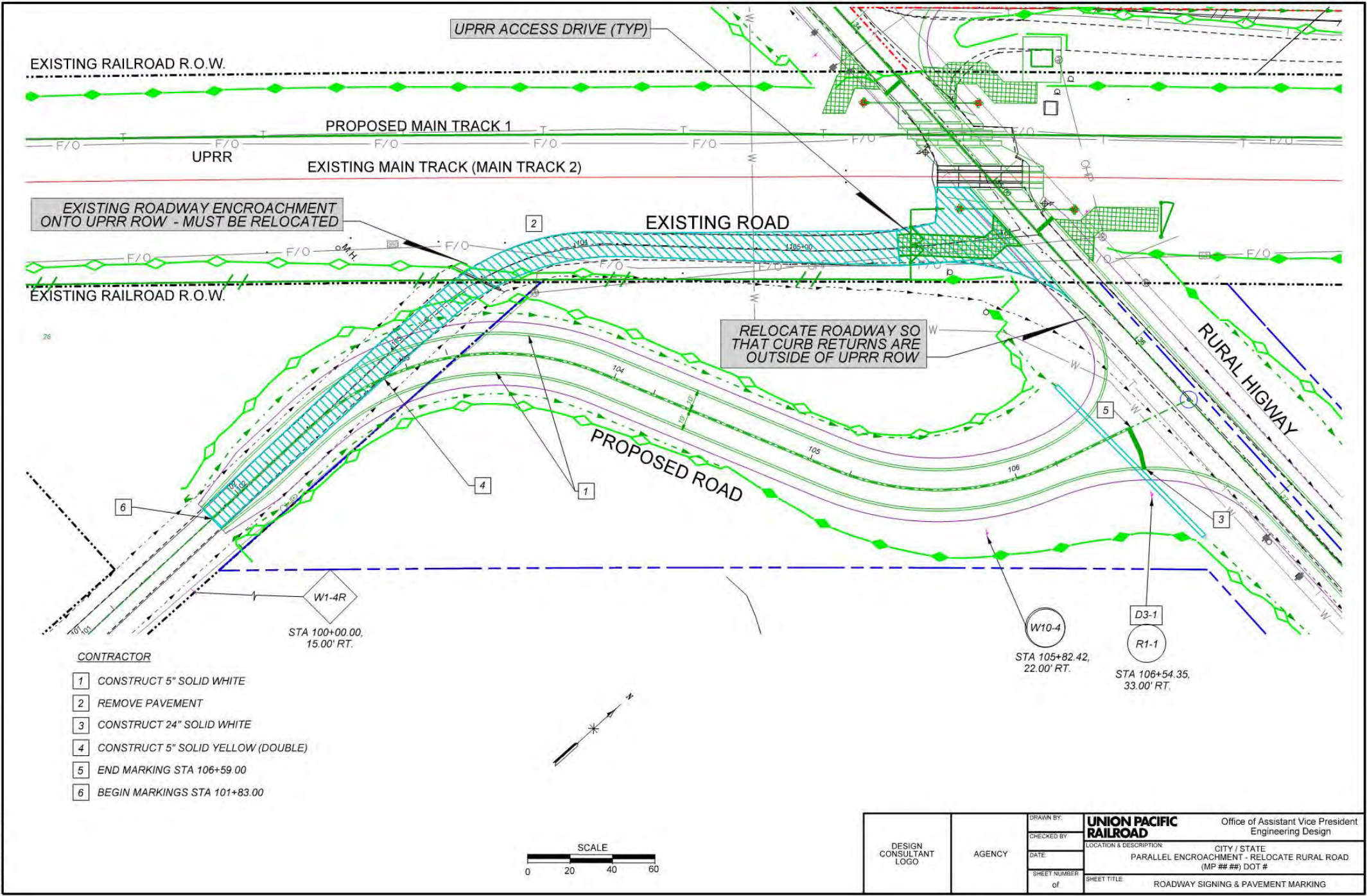

CONTRACTOR

- 1 CONSTRUCT 5" SOLID WHITE
- 2 REMOVE PAVEMENT
- 3 CONSTRUCT 24" SOLID WHITE
- 4 CONSTRUCT 5" SOLID YELLOW (DOUBLE)
- 5 END MARKING STA 106+59.00
- 6 BEGIN MARKINGS STA 101+83.00

DESIGN CONSULTANT LOGO	AGENCY	DRAWN BY:	UNION PACIFIC RAILROAD	Office of Assistant Vice President Engineering Design
		CHECKED BY:		
		DATE:		
		SHEET NUMBER of		
		LOCATION & DESCRIPTION:	CITY / STATE PARALLEL ENCROACHMENT - RELOCATE RURAL ROAD (MP ##) DOT #	
		SHEET TITLE:	ROADWAY SIGNING & PAVEMENT MARKING	

Appendix K Drainage Criteria

**UNION PACIFIC RAILROAD
SCOPE OF HYDROLOGIC/HYDRAULIC
DESIGN ENGINEERING AND PERMITTING SERVICES
FOR SIZING WATERWAY OPENINGS
AT NEW AND REPLACEMENT STRUCTURES**

These flood passage criteria were developed exclusively to protect Union Pacific Railroad (UPRR) infrastructure from flood damages and apply only to design and construction of new or replacement structures (such as bridges and culverts). Existing structures were designed and installed to protect UPRR facilities. For existing structures, UPRR relies upon guidance regarding 49 C.F.R. 213.33 found in the Federal Railroad Administration *Track Safety Standards Compliance Manual*: "Most railroad drainage structures have existed for many years and, if properly maintained and kept free of debris, they are considered adequately designed to accommodate expected water flow, even though recent high-water marks may be slightly above the inlet opening."

As part of investigating potential new or replacement structures, the hydraulic performance of the existing structure may be compared to these criteria. This is done only to establish a baseline condition for evaluation of alternatives, does not imply applicability of these criteria to an existing structure, and in no way reflects the ability of the existing structure to fully meet the standards of care in force at the time the structure was designed and constructed.

UPRR criteria for sizing waterway openings under bridges and through culverts are as follows:

1. New and replacement openings shall be sized for two high water events, designated "low chord" and "subgrade."
 - For subdivisions and for any lines in urban areas (regardless of classification), the low chord event is the 50-year flood and the subgrade event is the 100-year flood.¹
 - For industrial leads and for customer-owned trackage (not in urban areas), these events are the 25-year and 50-year floods, respectively.
 - If the structure is in a FEMA designated floodplain, however, the water surface elevations for a 100-yr event shall be determined regardless of line classification or FEMA zone.
2. The new or replacement opening will be sized, if possible, so that the water surface for a "low chord" event will rise no higher than the crown of the culvert or the low chord of the bridge.
3. The new or replacement opening will be sized, if possible, so that the energy grade line for a "subgrade" event will not rise above the adjacent subgrade elevation (defined as 2 feet below base of rail elevation).

¹ This document refers to flood events of a magnitude that is expected to be equaled or exceeded once on the average during any 25-, 50-, or 100-year period (recurrence interval). These events, commonly termed the 25-, 50-, and 100-year floods, are more correctly identified as the 4-, 2-, and 1-percent-annual-chance floods, and have a 4-, 2-, and 1-percent chance, respectively, of being equaled or exceeded during any year. Although the recurrence interval represents the long-term, average period between floods of a specific magnitude, rare floods can occur at shorter intervals or even within the same year.

4. Both the UPRR criteria and local flood flow criteria shall be evaluated, and the more conservative of the two shall be adopted in sizing the waterway opening for the new or replacement structure.
5. If the existing bridge or culvert waterway opening exceeds that required by the replacement criteria, a smaller opening will be recommended, based on the criteria.
6. If the waterway opening for an existing bridge or culvert is less than that required by the replacement criteria, a larger opening will be proposed. This enlargement will be lateral to the extent possible. If it is found that insufficient channel area exists to meet the criteria, even with maximum widening, consideration will be given to adding relief structures on the overbank floodplain, raising the railroad grade, or other alternatives.

The Consultant will typically observe the following procedures:

1. Review descriptive documents provided by UPRR. These will typically include railroad alignment maps, profile maps, and condensed profile pages. These documents, and any other information that may be supplied by UPRR, are proprietary to UPRR and are not to be used for any purpose other than the assigned study without the written consent of UPRR.
2. Research the site. Locate the bridge on a USGS quad map. Determine if the assigned bridge or culvert appears to be one of multiple structures which receive runoff from one drainage area. Contact federal, state, and local agencies to ascertain permit requirements and schedule a meeting in the field if required. Obtain local and state information and/or previous studies regarding historical or calculated flows at the site. Ascertain if the assigned structure is within a regulated floodplain. If so, obtain the Flood Insurance Rate Map, Flood Insurance Study, and regulatory hydraulics model, if available.
3. Using researched data, perform hydrologic calculations to establish preliminary low chord and subgrade event (including 100-year if needed) peak flow rates at the sites, using peak flow formula procedures or runoff hydrograph analysis, e.g. rational method, regression equations, SCS TR-55, HEC-1, HEC-HMS (Clark's or Snyders method), or other generally accepted methods for determination of runoff quantities at specified probabilities.
4. Visit the site. Contact the appropriate UPRR Manager Bridge Maintenance prior to the site visit to establish communications, schedule the trip, inquire as to any recommendations or special conditions to be considered, obtain guidance regarding access, and (in cases of difficult access) secure transportation to the site. The Structures Design group will provide UPRR alignment and profile maps, if available, for the vicinity.
5. Research and data collection shall include, but not be limited to, the following: (1) photograph the bridge opening, channel, abutments, and footings; (2) examine local scour problems and other site conditions, such as the presence of wetlands or potential critical habitat for threatened or endangered species; (3) obtain information, if available, on flow and foundation conditions at other existing bridges in near proximity; (4) inspect the main channel and portions of the overbank area and obtain cross-section information required for hydraulic analysis; and, unless specifically directed otherwise, (5) obtain top-of-rail elevations (at bridge

6. Using acquired maps, reports, field data, and local criteria, interpret data and refine hydrologic calculations to establish final low chord and subgrade event (including 100-year if needed) peak flow rates at the sites.
7. For the computed flow rates, evaluate the hydraulics of the existing structure using HEC-RAS, HY-8, WSPRO, HEC-2 or other techniques acceptable to UPRR and governing agencies. Compare the results with the current hydraulic criteria for flood passage, taking care not to imply that the existing structure is or ever was required to meet these standards.
8. Propose a waterway opening to meet the current UPRR hydraulic criteria, using the same technique as for the existing structure. Unless directed otherwise, evaluate the replacement structure by maintaining the existing track and embankment alignment and elevation. If more than one type of structure may be feasible, propose openings for each practical structure type.
9. In the event a practical and reasonable replacement structure meeting these criteria cannot be obtained, contact the UPRR Manager Structures Design for direction. Possible alternatives for discussion include raising the track and subgrade elevations and/or relaxing UPRR hydraulic criteria, but only with UPRR direction.
10. If it appears likely that a significant reduction from the existing bridge size can be made by further refining the hydrologic analysis, such as incorporating hydrograph routing, prepare a cost estimate for the additional analysis and then contact the UPRR Manager Structures Design for direction.
11. Assemble relevant data regarding the hydrology, existing structure hydraulics, and proposed structure hydraulics on a Union Pacific H&H Recommendation Form. Meet with the Structures Design staff (preferably in person) and present the recommendation form, field survey drawing, and photographs. Discuss the analysis and recommendation and obtain approval from UPRR to proceed with permitting for the adopted replacement structure.
12. On behalf of UPRR, make all contacts with permitting agencies, obtain and submit permit applications, and track progress of each permit. When permits have been obtained, transmit a "Permits Issued" letter, complete with original and one copy of permit documents, to UPRR for handling with construction forces. (Obtain all permits related to the new structure. If so directed by the Mananger Structures Design, obtain additional permits related to construction activities.)

Inasmuch as no two sites are alike, assumptions are made regarding availability of information, degree of difficulty in obtaining data, accessibility of the site, availability of suitable maps, technological complexities, etc. The following paragraphs give general guidelines.

The Consultant shall prepare a field survey drawing showing the following, with all elevations recorded to the nearest hundredth of one foot:

- Location map.
- Bridge elevation showing locations and dimensions of abutments, footings, piers, pile bents, and cut off piles from previous structures.
- Cross section at bridge or culvert showing flow line profile.
- Typical embankment cross section adjacent to bridge or culvert.
- Plan view showing relative adjacent structures such as switches, signs, utilities, bench marks, etc.
- Top-of-rail profile for at least 1000 feet either side of bridge or culvert (longer if necessary to include vertical and horizontal curves).
- When located within the survey limits, top-of-rail elevations at each side of road crossings, point and frog of railroad turnouts, backwalls of other bridges, etc.
- Location and set elevation of temporary bench mark at project site. The temporary bench mark shall be at a secure location and clearly identified.

Base of rail elevation shall be calculated based on height of rail weight present, subtracted from the surveyed top-of-rail elevation.

For super-elevated track, the controlling elevation for the profile is at the low rail.

If the existing substructure is steel, concrete, or a composite of steel and concrete the Consultant shall prepare a supplemental field survey drawing showing the following:

- Elevations of all bridge seats referenced to the benchmark and base of rail of the hydrologic and hydraulic survey.
- Lateral and longitudinal dimensions including lateral offsets from centerline of track of all bridge seats.
- Longitudinal dimensions locating the backwalls and centerline of bridge seats.
- If there are any riser blocks, grillages, or shims between the bridge seat and the structure, detailed drawings shall be completed showing all dimensions.

Base of rail elevation at one end of existing structure should generally be set at elevation 100.00. If elevations can be referenced to a nearby benchmark, provide the conversion from the assumed datum to a geodetic datum.

New and replacement bridge structures shall generally be steel beam spans, double-cell concrete box beams or slab beams, concrete box culverts, circular corrugated metal pipe culverts, or smooth steel pipe culverts. Unless otherwise directed, structures will be per UPRR structure standards, including roadbed sections for track construction, prestressed concrete trestles, corrugated metal pipe culverts, and reinforced concrete box culverts.

Measurements of cross-sections for hydraulic analysis generally shall be referenced to base-of-rail at the assumed elevation datum, and not a local geodetic system. Elevations are to be recorded to the

nearest one-hundredth ft. It is assumed that four to six channel cross sections will be surveyed at each site. Estimates of ordinary high water elevation and zero damage elevation for upstream developed properties are to be obtained.

It is assumed that horizontal control can be obtained from available topographic maps. If required by local or state criteria, horizontal and/or vertical control shall be established by the Consultant.

For tidal areas, it is assumed that hydrology can be obtained using the same techniques as for non-tidal sites. If, in the judgment of the Consultant, further refinement is required, he will so recommend and obtain approval from the UPRR Manager Structures Design before proceeding.

If an assigned bridge or culvert appears to be one of multiple structures which receive runoff from one drainage area, the Consultant shall bring this to the attention of the UPRR Manager Structures Design prior to making the site visit. When so directed, the Consultant shall obtain field information on all affected structures and include them in the analysis.

For travel to sites, the Consultant will make every reasonable effort to group sites so that field work can be completed for several sites during one trip. Airfare discounts for advance purchase should be obtained as standard practice, except when specifically directed otherwise by UPRR.

Permit letters shall conform to the following:

1. Permit letters shall identify what UPRR proposes to do, what additional information is included, a request for permit determination, and where additional information can be obtained or questions answered.
2. Requests for permits shall be made to all agencies that have jurisdiction. Some agencies will request notification only and have no formal permit requirements. Some agencies may claim jurisdiction without legal authority; the Consultant should verify, as much as possible, validity of jurisdiction.
3. All permits and forms will be completed and signed by the Consultant acting on behalf of UPRR.
4. One letter shall be used to notify as many agencies as practical.
5. All required figures, tables, and supporting information, as well as a photograph of the existing structure, will be included with the permit letter.
6. Where permits require payment of fees, supporting forms and documents will be submitted in completed form and payment made by the Consultant.
7. Consultant will type and sign all final correspondence. UPRR will receive a copy of all correspondence.
8. Upon receipt of permit approvals from the agencies, the Consultant shall transmit a "Permits Issued" letter to UPRR stating that relevant permits have been issued and summarizing those

permits. The Consultant shall also name any known permits that have not been obtained and are expected to be obtained by construction forces.

Revised 1 November 2010



Appendix L Commuter Access Principles

Union Pacific Commuter Access Principles

Union Pacific offers the following information to guide commuter rail planners and agencies in working with Union Pacific to develop new rail passenger service. Commuter rail service can provide substantial benefits to the public, including reducing traffic congestion and avoiding expensive highway construction. At the same time, Union Pacific has a responsibility to the nation and to its customers to protect the public benefits of freight transportation - energy efficiency, lower emissions, cost-effective cargo transportation for shippers and consumers, and private investment in the nation's infrastructure.

Union Pacific will consider reasonable proposals for commuter rail service that appear to be viable and adequately funded. Commuter rail planners and agencies should recognize that agreements reached in the past, when railroads had excess track capacity and did not expect to grow, are not appropriate models for future agreements. Future agreements must balance the nation's desire for additional commuter services with Union Pacific's ongoing, critical role in carrying freight that otherwise would likely compete for space on the crowded and underfunded highway network.

Feasible separation of freight and passenger operation

- As in all our activities, safety must come first.
- Passenger safety is best protected by separating freight and passenger tracks by 50 feet or more. Despite UP's enormous progress in preventing freight train derailments, derailments will occur and could strike or be struck by passenger trains. Research demonstrates that most freight train derailments will remain within a 100-foot corridor.
- One way to achieve separation is to move the majority of freight trains out of urban corridors entirely. UP will consider publicly funded relocations of freight operations that preserve UP's customer service, competitive position, and access to current and future freight customers.

Where separation or relocation is not feasible, commuter trains must share our tracks. We intend to apply the following principles in negotiating proposals by commuter agencies for joint operations:

Safety

- Under federal law, all trains and tracks must in the future be equipped with interoperable Positive Train Control (PTC) systems if passenger trains are present. The commuter agency should fund PTC if UP would not otherwise install it on the affected track, or contribute the agency's share of equipment and way-side costs if UP would install PTC on the affected track.
- Each occupied locomotive must be equipped with a working radio that can communicate with Union Pacific Railroad during an emergency event and shall comply with 49 CFR Part 220.9.
- Operations and equipment must comply with all applicable Union Pacific rules.
- Commuter agencies should fund all other incremental safety requirements attributable to its service, including track quality upgrades, grade crossing warning signal improvements, new grade separations, and any required fencing.
- Passenger vehicles must, at a minimum, meet all applicable safety standards, including FRA, APTA and AAR standards. This includes FRA crashworthiness standards applicable to passenger train operating on freight main lines. Vehicles must also be fully interoperable with UPRR infrastructure and freight operations
- Passenger stations must meet Union Pacific and FRA design requirements to protect passengers from freight operations.

Service

- Passenger equipment must be reliable and suitable for mainline operations.
- Service to Union Pacific's freight customers must also be reliable and protected and should not be compromised by new commuter rail service. UP cannot agree to curfews or other restrictions that would impact the quality or reliability of our freight service.
- Commuter service design and infrastructure investment must protect UP's ability to serve existing customers and locate new freight customers on our lines.
- In order to preserve service quality for all types of customers, UP will retain dispatching and maintenance control over its lines. The parties must agree on standards for reliability.
- Passenger operations must provide the flexibility to accommodate efficient track maintenance.

Liability

- UP cannot accept exposure to any additional liability associated with allowing commuter service on our lines that would not exist “but for” those operations.
- Commuter agencies should be prepared to carry and provide evidence of insurance covering liability exposure up to the limit of liability under federal law, currently \$294M. Union Pacific expects to be indemnified for or protected against any and all liability resulting from the presence of commuter service.

Capacity

- All projections call for rail freight growth to exceed rail capacity in the future. Commuter agencies should understand that existing capacity that UP funded—whether or not now used—is reserved for potential freight growth.
- Commuter agencies therefore must fund all incremental capacity to accommodate commuter operations, as reflected in a study of capacity requirements and a resulting capacity plan.
- The capacity plan must preserve the opportunity to expand freight service.
- Because new capacity consumes the least expensive capacity opportunities and usually makes the next increment of capacity more expensive, the capacity plan must include additional commuter agency investment at the outset that will leave UP cost-neutral when it needs to invest in additional freight capacity.
- Infrastructure requirements will be determined by UP or a UP-designated and qualified third party.
- On certain rail lines where freight growth is not expected, UP may allow commuter rail use of existing, unused capacity.

Compensation

- The commuter agency should be prepared to pay for all costs associated with developing the capacity plan, including UP’s time and resources.
- The capacity plan should be based on UP’s actual cost structures and operating conditions, not on idealized conditions or models.
- To the extent commuter agencies use UP assets and property, they must provide UP with a reasonable return on Union Pacific’s investment.
- UP will seek fair market rates for access. Traditional “incremental cost” formulas are no longer acceptable
- If UP’s tax liabilities (income, franchise, sales and use, property, or any other tax) increase as a result of UP’s participation in a passenger project, UP expects to be made whole.



Appendix M Special Conditions for Construction Near UP Property

"SPECIAL CONDITIONS"

XXXXXX Subdivision, MP XXX.X to MP XXX.X

XXXXX Siding Extension

Month Date, Year

Addendum #X (Fill in submittal milestone, ie For Bid, Addendum #X, Final)

INSTRUCTIONS: Items in red will need to be changed for each specific project. Please contact xxxxxx prior to making other changes to the language.

Section 00 07 00 General Conditions

1. All work must be performed within the confines of existing UPRR right-of-way, proposed right-of-way, construction easements, or public roadway right-of-way.
2. Contractor will be responsible for any and all permits and licenses not specifically provided by UPRR.
3. Train movements may occur at any time of the day and will not be limited by an amount. The number of trains operated daily on the **XXXXXX Main Track** is approximately **XX**, with a maximum speed of **XX MPH**.
4. If the Contractor discovers evidence of possible scientific, prehistoric, historical, or archaeological significance, the Contractor will stop all activity in the vicinity of the discovery and promptly notify the Engineer giving the location and nature of the findings. Until the findings have been examined, the Contractor shall exercise necessary care to protect and prevent damage to the findings.
5. Contractor is responsible for making sure all applicable State and Local taxes and fees are accounted for in the bid and throughout the project.
6. All prospective bidders shall visit the site to familiarize themselves with the existing site conditions, access locations, site constraints, existing site drainage, and existing utilities within the project area. In addition, the selected Contractor shall verify the location, elevations and flowlines of existing utilities that may be in conflict with the proposed work or that will need to connect to the new work prior to start of construction. This may require the Contractor to pothole existing utilities in advance of the start of work to verify elevations at outlets, crossings, or connection points, location and depth of utilities, size and or material types of existing utilities. This verification work shall include but not be limited to connections to existing gas lines, fiber optic lines, sanitary lines, storm sewers, water mains, electrical and communication lines. Verification of existing site conditions and utility locations is considered incidental. If the Contractor determines these utilities are in conflict with proposed construction or do not meet minimum depth of cover requirements, the Contractor shall promptly notify the UPRR Engineer.
7. The following Bid Forms require completion and submittal with the Contractor's bid:
 - a. Bid Form (Exhibit H) with project completion date of **Month Day, 20xx**.
 - b. Bid Form (Exhibit H) with project completion date of **Month Day, 20xx**.
8. Unit prices will be established from the Exhibit H bid forms. Due to the accelerated nature of the project, actual project quantities are subject to change. If applicable, the established unit prices may be reevaluated where revised quantities vary 30% or more from those provided with Contractor's submitted bid. Contractor shall not change quantities in "Exhibit H".
9. All bid documents were created with a desktop evaluation for existing ground surface, railroad GPS top of rail information, existing soils, hydrology and hydraulics, and permit assessment. The full field investigations including survey, geotechnical, hydrology and hydraulics, and permit/wetland delineation will be performed and received through-out the bid process. As the deliverables for these field investigations are received, bid documents will be updated into full construction plans.
10. All bidders shall submit a resource loaded, task driven critical path method schedule, work plan and monthly spending plan along with their bid proposal. The schedule and work plan shall include the following information: type and quantity of equipment, manpower, man hours, hours per day to complete each task. The schedule shall indicate the number of calendar days required for each critical

item. In determining the calendar days the Contractor shall consider weather and local conditions which are normal for this area. Contractor's bid may not be considered if these documents are not included in the bid.

Section 01 14 12 Working and Flagging near Tracks

1. The Contractor shall develop and submit an Emergency Response Plan to the on-site UPRR Engineer.
2. The Contractor shall provide one (1) 4WD pickup truck or flagging purposes per project location. The vehicles shall be suitable for the type of terrain typically encountered to access the project along the Railroad right-of-way and shall meet the following requirements: four-wheel drive, automatic transmission and five years or newer model year. Vehicles will be insured, fueled, and maintained by the Contractor and shall be paid for as EQMT, PICKUP TRUCK.

Section 01 31 10 Project Coordination

1. The Contractor shall coordinate all construction activities directly with UPRR. As part of coordination with UPRR work gangs, the Contractor can expect to work alternate work periods. This may require working nighttime hours and through holidays and weekends. The Contractor shall account for all related coordination and work periods within their bid. There may be delays associated with UPRR track and signal gang activities; track gangs work consolidated work periods. Contractor delays associated with coordination with UPRR crews and railroad operations shall not constitute a change order.
2. The Contractor will supply UPRR EIC, Contractor(s)-In-Charge (CIC), and UPRR's Construction Project Manager(s) a radio so that they may contact all equipment operators about the status and location of trains.
3. The Contractor shall coordinate material storage and staging areas with UPRR. Anticipated material storage areas are as follows:
 - a. **Subballast:** MP XXXX.XX near XXXXXX
 - b. **Ties and OTM:** MP XXXX.XX near XXXXXXXX
 - c. **Bridge Material:** MP XXXX.XX near XXXXXXXX
4. The Contractor is responsible for coordinating cost and terms of usage for any staging areas and access with adjacent property owners. Documentation of all agreements with property owners shall be provided to the UPRR Engineer.
5. The Contractor shall not work within areas beyond existing UPRR right-of-way without prior written approval from the UPRR Engineer. Construction phasing shall be scheduled and performed to account for the following:
 - a. Construction activities shall be limited to areas and performed in accordance with the Conflict Resolution Matrix.
 - b. Coordination and relocation of fiber, utilities, and overhead power shall be completed prior to construction activities conflicting with existing conditions.
 - c. Utility relocations and construction activities shall not occur until property matters, agreements, necessary permitting, and agency/UPRR approvals occur.
 - d. Depending on the Contractor's work plan and areas available to perform work, the Contractor may need to temporarily stockpile materials until restricted areas are released.
6. Fiber and utility relocations will be required per the Utility Matrix, Utility Layout, and as determined by Contractor verification. Relocations or protections shall be made prior to construction activities conflicting with existing facilities. The Contractor shall coordinate all grading and construction activities with UPRR. Contact information:

Name XXXXXXXX
Title XXXXXXXX
Phone XXXXXXXX
Email XXXXXXXX

Section 01 33 00 Submittal Procedures

1. All submittals shall be made electronically unless otherwise specified by the UPRR Engineer and submitted to **XXXXXXXX@up.com** and copied to **XXXXXXXX@up.com**).
2. The Contractor shall not include change orders with invoices until after they are fully executed by UPRR.
3. The document management system utilized by the Contractor must be compatible with UPRR systems.

Section 01 51 36 Water

1. Water used for excavation, embankment pre-wetting, moisture control, and dust control shall be obtained by the Contractor. The Contractor shall not use water from rivers, streams, canals, or wells unless prior written agreements have been obtained from adjacent landowners, water users (appropriators), or appropriate water authorities (local, state, or federal). Use of water is subject to state water laws and water rights. Impacts to riparian and wetland vegetation along drainages due to water use shall be minimized, as required by federal and state laws. Contractor must supply water and furnish a water resource plan, with the delivery method outlined. The Contractor shall submit a list of anticipated water sources with the bid. The water source must be approved by UPRR prior to usage.

Section 01 52 13 Office Space for Contractor and Engineer

1. A separate job trailer for the UPRR Engineer will not be necessary; however, an office with internet/communications and sufficient ice supply for work crews should be made available for UPRR in the Contractor’s job trailer. The space shall contain the items required in Section 01514 of the General Conditions and shall also include an internet connection, color printer, printing supplies that are capable of printing the railroad operational paperwork including but not limited to “Dispatcher Bulletins” and other safety documentation. The Contractor shall provide access to UPRR management and Construction management personnel to printer and supplies. Separate payment will not be made for UPRR accommodations, which shall be considered incidental to mobilization.

Section 01 55 13 Access Roads and Crossings

1. Temporary crossing for access during construction, if required, shall be constructed to conform to the requirements detailed in the UPRR drawing “Typical Temporary Asphalt Crossing”. Construction activities may include clearing and grubbing, placement of suitable fill material, placement of asphalt and filter fabric, and installation of any drainage structures required to ensure positive drainage. When the temporary crossing is no longer required, the Contractor shall remove all related materials and perform grading as necessary to maintain positive drainage. The Contractor shall also seed and restore the area to a state equal to or better than previous conditions to the satisfaction of the UPRR Engineer. As necessary, the Contractor shall be responsible to provide a flagman to attend to each temporary crossing when it is open to traffic. Crossing must be secured by lockable gates or other approved devices when unattended. Location must be approved by the UPRR Engineer prior to installation. Construction, maintenance, and removal of temporary crossings shall not be paid for directly and are considered incidental.

Section 01 56 24 Fencing and Barricades

1. Sensitive areas exist along the limits of the project. The Contractor shall construct temporary construction fence along delineated wetlands and waterways and post appropriate signage along the fence to prevent disturbance and encroachment of construction activities to environmentally sensitive areas not explicitly impacted by the proposed grading footprint.
2. Temporary construction fence used shall be a high visibility orange color, composite fence, a minimum of 42” high, supported and tightly secured to steel posts located on maximum 10’ centers.
3. As directed by the UPRR Engineer, the Contractor shall furnish, install, maintain the temporary construction fence in a satisfactory condition for the duration of the project, and remove the

temporary construction fence upon completion of construction. Temporary construction fence construction is considered incidental.

Section 01 71 23 Field Engineering

1. Line Item 'EQMT, SURVEY CREW' is for surveying of field changes and must be approved by the UPRR Engineer. All other surveying including track layout is incidental to Contractor's bid. Surveying crew hourly rate should be based off a 4-hour minimum and include equipment and per diem.

Section 31 24 13 Excavation, Embankments and Other Fills

1. The Contractor shall place subballast on the turnout construction pads as soon as practical to provide flexibility for turnout construction.
2. Any damage to either the subballast surface or side slopes caused by the Contractor's operations shall be repaired at the Contractor's expense to the satisfaction of the UPRR Engineer.
3. The following Line Items are estimated quantities to establish a unit price and may or may not be required. The Contractor shall only use the following items with prior approval and as directed by the UPRR Engineer:
 - GRAD, EXCAVATION, SUBEXCAVATION
 - GRAD, EMBANKMENT, SELECT FILL
 - GRAD, STAB, GEOGRID
 - GRAD, STAB, GEOTEXTILE, NON-WOVEN
 - GRAD, EMBANKMENT, STONE, B
 - **GRAD, STAB, LIME, MATERIAL**
 - **GRAD, STAB, LIME, TYPE A HYDRATED LIME**
 - Miscellaneous equipment rental items
4. The construction of signal mounds and wayside detectors inside the project limits are included in the appropriate subballast line items. Additionally there are locations that are outside of the project limits that will require signal mounds. Payment for grading and subballast placement of signal mounds outside project limits shall be included in Line Item GRAD, SIGNAL MOUND, INTERMEDIATE and includes all materials, equipment, tools, labor, and incidentals necessary to haul, place, and compact earth and subballast. Contractor shall coordinate with the Engineer to determine final locations prior to construction of all signal mounds. The grading of such signal mounds shall be performed per reference document "Typical Intermediate Mounds". Where placement of a signal mound impacts existing drainage patterns, the surrounding area shall be re-graded to drain. Signal mound placement and grading to maintain drainage is incidental GRAD, SIGNAL MOUND, INTERMEDIATE.
5. If import soil is needed refer to the Import Soil Qualifications for specification.

Section 31 35 20 Slope Protection and Erosion Control

1. The requirements for Stormwater Management are specified in the All Permits Issued Package.
2. A draft SWPPP has been prepared and is included in the contract documents and All Permits Issued Package. The Contractor shall be responsible for finalizing the draft SWPPP as well as implementing and maintaining the SWPPP in accordance with the XXXXXXXX agency.
3. **Contractor shall be responsible for modifying the draft SWPPP for site-specific conditions and Contractor selected method-specific implementation, filing the Notice of Intent (NOI) at least seven (7) days prior to commencing construction activity, and filing the Notice of Termination (NOT) upon completion of the project.**

Section 31 37 00 Riprap

1. Riprap removed as part of this contract may be used for placement at other locations. Removed riprap

1. Bridge and culvert construction located adjacent to existing tracks shall be installed under traffic.
2. Relocation of established survey markers (USGS, State of ~~XXXX~~, etc.) is incidental to bridge/culvert work. If necessary, relocation or reset shall be by a Licensed Land Surveyor in the state in which the relocation is being performed and the contractor shall provide all appropriate documentation.
3. The Contractor shall be responsible for localized grading at all structures as required to tie into existing and proposed drainage channels as necessary to maintain positive drainage. Channel relocations shall be completed to match flowlines and cross sections of the existing drainage channel.
4. UPRR will evaluate procurement and delivery of bridge materials as follows:
 - a. As part of the Contractor's Base Bid, the Contractor is responsible for procurement and delivery of all bridge materials included with the Bill of Materials. Payment shall be made under Line Item 'STRC, BRIDGE, CONSTRUCT, INSTALL'. Payment shall be full compensation for all materials, equipment, tools, labor, and incidentals necessary to complete the work.
 - b. As an alternate, UPRR is responsible for procurement and delivery of all bridge materials included with the Bill of Materials with exception to riprap, concrete for pile sockets, temporary shoring, sealant ballast, and construction adhesive for bearing pads. Line Item 'STRC, BRIDGE, CONSTRUCT, UPRR SUPPLIED' is an Alternate Line Item that shall be full compensation for all offloading, hauling, materials, equipment, tools, labor, and incidentals necessary to complete the work. If this Alternate Line Item is accepted, it shall replace Line Items 'STRC, BRIDGE, CONSTRUCT, INSTALL'.
5. The Contractor shall be responsible for procurement of all culvert pipe material.

Section 33 42 00 Culverts

1. Bridge and culvert construction located adjacent to existing tracks shall be installed under traffic.
2. Relocation of established survey markers (USGS, State of ~~XXXX~~, etc.) is incidental to bridge/culvert work. If necessary, relocation or reset shall be by a Licensed Land Surveyor in the state in which the relocation is being performed and the contractor shall provide all appropriate documentation.
3. The Contractor shall be responsible for localized grading at all structures as required to tie into existing and proposed drainage channels as necessary to maintain positive drainage. Channel relocations shall be completed to match flowlines and cross sections of the existing drainage channel.
4. UPRR will evaluate procurement and delivery of bridge materials as follows:
 - a. As part of the Contractor's Base Bid, the Contractor is responsible for procurement and delivery of all bridge materials included with the Bill of Materials. Payment shall be made under Line Item 'STRC, BRIDGE, CONSTRUCT, INSTALL'. Payment shall be full compensation for all materials, equipment, tools, labor, and incidentals necessary to complete the work.
 - b. As an alternate, UPRR is responsible for procurement and delivery of all bridge materials included with the Bill of Materials with exception to riprap, concrete for pile sockets, temporary shoring, sealant ballast, and construction adhesive for bearing pads. Line Item 'STRC, BRIDGE, CONSTRUCT, UPRR SUPPLIED' is an Alternate Line Item that shall be full compensation for all offloading, hauling, materials, equipment, tools, labor, and incidentals necessary to complete the work. If this Alternate Line Item is accepted, it shall replace Line Items 'STRC, BRIDGE, CONSTRUCT, INSTALL'.
5. The Contractor shall be responsible for procurement of all culvert pipe material.

Section 34 11 10 Railroad Track Construction

1. All project material supplied or delivered by truck and/or railcars will be the responsibility of the Contractor to unload, stockpile for project use, inventory, and secure from loss or theft. Once material is delivered to the project it becomes the responsibility of the Contractor to safeguard and replace if items are missing. This is incidental to the track construction unit bid prices.
2. All stockpile locations shall be coordinated and approved by the UPRR Engineer.
3. Railroad will provide 24 hours-notice of planned delivery and Contractor shall immediately unload track materials upon arrival, no matter the time of day or day of week. Where material must be unloaded from the main track adjacent to the project, such as for rail, Contractor should anticipate work windows of less than 4 hours. Contractor is responsible for inventory and protection of this material once unloaded.
4. Installation of transition rails, insulated joints, welds, transition ties, OTM, and VERSE testing shall be incidental to track construction.
5. The Contractor shall be responsible for assembly and construction of all turnouts, including those to be installed by UPRR. Handling and assembly of turnouts shall be in accordance with Section WPD 5.01 of UPRR's Engineering Track Maintenance Field Handbook.
6. UPRR will evaluate assembly of turnouts as follows:
 - a. As part of the Contractor's Base Bid, the Contractor is responsible for unloading, hauling and assembly of loose materials provided by UPRR. Payment for turnout assembly shall be made under Line Item 'TRAK, TURNOUT, NO. 15 PO WOOD, ASSEMBLE'. Payment shall be full compensation for all materials, equipment, tools, labor, welds, and incidentals necessary to complete the work.

- b. As an alternate, the Contractor is responsible for unloading, hauling and assembly of panelized turnouts provided by UPRR. Line Item "TRAK, TURNOUT, NO.15 PO WOOD, PANELIZED, ASSEMBLE" and/or "TRAK, TURNOUT, NO.11 HT WOOD, PANELIZED, ASSEMBLE & INSTALL" is an Alternate Line Item that shall be full compensation for all materials, equipment, tools, labor, welds, and incidentals necessary to complete the work. If this Alternate Line Item is accepted, it shall replace Line Items "TRAK, TURNOUT, NO.15 PO WOOD, ASSEMBLE" and/or "TRAK, TURNOUT, NO.11 HT WOOD, ASSEMBLE & INSTALL". Panelized turnouts will be delivered to the locations referenced in Section 01 31 10.
7. The Contractor shall be responsible for assembly of track to be installed by UP forces at the locations indicated on the plans. Payment for track assembly shall be made under Line Item "TRAK, WOOD, SKELETONIZE". Payment shall be full compensation for all materials, equipment, tools, labor, welds, and incidentals necessary to complete the work.
8. The Contractor will dispose of removed abandoned track material offsite. All abandoned track to be removed by contractor shall be included in the DEMO, TRACK DISPOSE bid item. Loose ties removed by UPRR track forces and placed clear of the track shall be disposed off site by the Contractor. The Contractor shall haul and dispose of loose ties off site in a legal manner. Hauling and disposal of loose ties shall be included in the DEMO, TRACK, TIES, DISPOSE bid item.
9. The Contractor shall dispose of all ties, rail, and OTM removed by UP forces or the Contractor shall be disposed of in a legal and proper manner.
10. At the end of the project, the Contractor shall load all excess track material in railcars and/or stockpile at a designated location as directed by the UPRR Engineer.
11. The Contractor shall mark clearance points in accordance with Standard Drawing 0026C and mark culvert locations in accordance with Standard Drawing 0519B. This work is considered incidental.
12. The siding track construction shall be constructed with wood ties at 24" centers with SH 133# CWR or New 136# rail. Ribbon rail will be delivered by rail.
13. Ties will be supplied with both 14" plates and 16" plates. The ties with the 14" plates should only be used in the tangent portions of the sidings. Curves and the turnback curves should be installed with 16" plates or curve blocks, depending on degree of curvature per Section 3.4 of the UPRR Engineering Track Maintenance Field Handbook.

Section 34 11 27 Subballast

1. UPRR will evaluate furnishment and placement of subballast material as follows:
 - a. As part of the Contractor's Base Bid, Line Item 'GRAD, SUBBALLAST, FURNISH' shall be full compensation for all materials, equipment, tools, labor, and incidentals necessary to supply subballast required for the project.
 - b. As part of the Contractor's Base Bid, Line Item 'GRAD, SUBBALLAST, PLACE' shall be full compensation for all materials, equipment, tools, labor, and incidentals necessary to place and compact subballast as required for the project.
 - c. As an alternate, Line Item 'GRAD, SUBBALLAST, HAUL & PLACE' is an Alternate Line Item that shall be full compensation for all materials, equipment, tools, labor, and incidentals necessary to haul, place, and compact subballast that has been supplied by UPRR instead of supplied by the Contractor, as required for the project. If this Alternate Line Item is accepted, it shall replace Line Items 'GRAD, SUBBALLAST, FURNISH' and 'GRAD, SUBBALLAST, PLACE'.
2. If applicable, UPRR will supply all subballast, which will be delivered by belt train.
3. Subballast volumes shown in the plans and as quantified for bidding are to the neat lines of the drawings and do not account for loss associated with hauling, stockpiling, handling, shrinkage, expansion, or other contributing factors. Additional payment will not be made for associated losses; the Contractor shall account for mobilization, transportation, stockpiling, transfer, loss, and all other factors associated with furnishment, transfer, placement, and compaction of subballast material.

Miscellaneous

1. The Question and Answer forum will close **Date & Time & Zone.**
2. Bids will be due **Date & Time & Zone.**